

iR C3200 series

SERVICE MANUAL

REVISION 0

Canon

JAN. 2003

FY8-13HV-000

Application

This manual has been issued by Canon Inc. for qualified persons to learn technical theory, installation, maintenance, and repair of products. This manual covers all localities where the products are sold. For this reason, there may be information in this manual that does not apply to your locality.

Corrections

This manual may contain technical inaccuracies or typographical errors due to improvements or changes in products. When changes occur in applicable products or in the contents of this manual, Canon will release technical information as the need arises. In the event of major changes in the contents of this manual over a long or short period, Canon will issue a new edition of this manual.

The following paragraph does not apply to any countries where such provisions are inconsistent with local law.

Trademarks

The product names and company names used in this manual are the registered trademarks of the individual companies.

Copyright

This manual is copyrighted with all rights reserved. Under the copyright laws, this manual may not be copied, reproduced or translated into another language, in whole or in part, without the written consent of Canon Inc.

COPYRIGHT © 2003 CANON INC.

Printed in Japan









Imprimé au Japon

Caution

Use of this manual should be strictly supervised to avoid disclosure of confidential information.

1 Symbols Used

This documentation uses the following symbols to indicate special information:

Symbol	Description
	Indicates an item of a non-specific nature, possibly classified as Note, Caution, or Warning.
	Indicates an item requiring care to avoid electric shocks.
	Indicates an item requiring care to avoid combustion (fire).
	Indicates an item prohibiting disassembly to avoid electric shocks or problems.
	Indicates an item requiring disconnection of the power plug from the electric outlet.
 Memo	Indicates an item intended to provide notes assisting the understanding of the topic in question.
 REF.	Indicates an item of reference assisting the understanding of the topic in question.
	Provides a description of a service mode.
	Provides a description of the nature of an error indication.

2 Introduction to the Manual

This Service Manual offers basic facts and figures needed to maintain the product quality of the iR C3200/C3200S and its accessories (Side Paper Deck-P1, 2-Cassette Pedestal-X1, and Plain Pedestal-C1) as done through servicing them in the field. For information on other accessories (e.g., DADF), see the separately available Service Manuals.

This Service Manual is made up of the following volumes, each consisting of the chapters described:

1. System

- Chapter 1 *Introduction* describes features and specifications; provides names of parts; describes functions; describes operation; describes systems; describes items of maintenance by the user
- Chapter 2 *Basic Operations (as a copier)* describes functional construction; describes arrangement of major PCBs; describes basic sequence of operations
- Chapter 3 *Main Controller* describes functional construction; provides outline of electrical circuitry; describes principles of image processing; describes control of power supply
- Chapter 4 *Installation* provides requirements for site of installation; describes procedure of installation work; describes procedure for machine relocation; provides instructions on installation of accessories

2. Reader

- Chapter 1 *Exposure* describes principles and timing of exposure; provides instructions on disassembly/assembly and adjustment
- Chapter 2 *Image Processing* describes principles and timing of image processing; provides instructions on disassembly/assembly and adjustment
- Chapter 3 *Externals and Controls* describes externals; describes principles and timing of main and auxiliary controls; provides instructions on adjustment; describes power supply

3. Printer Unit

- Chapter 1 *Introduction* describes safety of laser; describes image formation; describes auxiliary processes
- Chapter 2 *Basic Operations (as a printer)* describes basic operations; provides outline of electrical circuitry; describes basic sequence of operations
- Chapter 3 *Laser Exposure* describes principles and timing of laser exposure; provides instructions on disassembly/assembly and adjustment
- Chapter 4 *Image Formation* describes principles and timing of image formation; provides instructions on disassembly/assembly and adjustment
- Chapter 5 *Pickup and Feeding* describes principles and timing of pickup/feeding; provides instructions on disassembly/assembly and adjustment



- Chapter 6 *Fixing* describes principles and timing of fixing; provides instructions on disassembly/assembly and adjustment
- Chapter 7 *External and Controls* describes externals; describes principles and timing of main and auxiliary controls; provides instructions on adjustment
4. Accessories
- Chapter 1 *Side Paper Deck-P1* describes principles and timing of pickup; provides instructions on disassembly/assembly and adjustment
- Chapter 2 *2-Cassette Pedestal* describes principles and timing of operation; provides instructions on disassembly/assembly and adjustment
- Chapter 3 *Plain Pedestal* describes principles and timing of operation; provides instructions on disassembly/assembly and adjustment
- Chapter 4 *Cassette Heater* describes principles of operation; provides instructions on setup
- Chapter 5 *FAX Kit* describes principles of operation; provides instructions on setup
- Chapter 6 *UFR Printer and Scanner Kit-A1* describes principles of operation; provides instructions on setup
- Chapter 7 *Resolution Switching Board-A1* describes principles of operation; provides instructions on setup
- Chapter 8 *Color Universal Send Kit-A1P/A1U* describes principles of operation; provides instructions on setup
- Chapter 9 *USB Interface Board-A1* describes principles of operation; provides instructions on setup
- Chapter 10 *Color Network Multi-PDL Printer Kit-A1* describes principles of operation; provides instructions on setup
- Chapter 11 *iR Security Kit-A1P/A1U* provides instructions on setup
5. Troubleshooting
- Chapter 1 *Maintenance and Inspection* provides tables of periodically replaced parts and durables/consumables; provides scheduled servicing chart
- Chapter 2 *Standards and Adjustments* describes standards to meet and adjustments to make
- Chapter 3 *Correcting Faulty Images* provides instructions on how to identify and correct image/operation faults
- Chapter 4 *Self Diagnosis* provides table of codes; describes major causes; provides timing chart for detection
- Chapter 5 *Service Mode* describes how to use service mode; provides list of service mode items
- Chapter 6 *Upgrading* describes and provides instructions for upgrading firmware
- Appendix provides general timing chart and general circuit diagrams

The descriptions in this Service Manual are subject to change, and major changes will be communicated in the form of Service Information bulletins.

All service persons are expected to go through the descriptions in this Service Manual and Service Information bulletins (issued as needed) and develop a good understanding of the machine so that they are equipped with the knowledge and skill to service the machine, ensuring a specific level of product quality throughout its life.

The following rules apply throughout this Service Manual:

1. Each chapter contains sections explaining the purpose of specific functions and the relationship between electrical and mechanical systems with reference to the timing of operation.

In the diagrams,  represents the path of mechanical drive; where a signal name accompanies the symbol , the arrow indicates the direction of the electric signal.

The expression “turn on the power” means flipping on the power switch, closing the front door, and closing the delivery unit door, which results in supplying the machine with power.

2. In the digital circuits, ‘1’ is used to indicate that the voltage level of a given signal is ‘High,’ while ‘0’ is used to indicate ‘Low.’ (The voltage value, however, differs from circuit to circuit.) In addition, the asterisk (*) as in ‘DRMD*’ indicates that the DRMD signal goes on when ‘0’.

In practically all cases, the internal mechanisms of a microprocessor cannot be checked in the field. Therefore, the operations of the microprocessors used in the machines are not discussed: they are explained in terms of from sensors to the input of the DC controller PCB and from the output of the DC controller PCB to the loads.

The descriptions in this Service Manual are subject to change without notice for product improvement or other purposes, and major changes will be communicated in the form of Service Information bulletins.

All service persons are expected to have a good understanding of the contents of this Service Manual and all relevant Service Information bulletins and be able to identify and isolate faults in the machine.

System Unit

SERVICE MANUAL

Contents

CHAPTER 1 INTRODUCTION

1	System Construction	1-1	4.2	Points to Note When Turning Off the Main Power Switch	1-18
1.1	System Construction of the Pickup/Delivery Options	1-1	4.3	Control Panel	1-20
1.2	System Construction of Printing/ Communications Options	1-2	4.4	User Mode Items	1-21
1.3	Functions of Print/ Communication Options	1-3	4.4.1	Common Settings	1-21
1.4	Outline of the Print/ Communication Options	1-4	4.4.2	Timer Settings	1-22
1.4.1	UFR Printer and Scanner Kit-A1	1-4	4.4.3	Adjustments and Cleaning	1-22
1.4.2	Color Universal Send Kit-A1P/A1U	1-4	4.4.4	Report Generation	1-23
1.4.3	Resolution Switching Board-A1	1-4	4.4.5	System Control Settings	1-23
1.4.4	USB Interface Board-A1	1-4	4.4.6	Copier Specifications Settings	1-24
1.4.5	Super G3 FAX Board-M1 ...	1-4	4.4.7	Transmission/Reception Specifications Settings	1-24
1.4.6	Token Ring Board	1-4	4.4.8	Box Specifications Settings	1-25
2	Product Specifications	1-5	4.4.9	Printer Specifications Settings	1-25
2.1	General Specifications (including printer unit)	1-5	4.4.10	Destinations Table Specifications Settings	1-25
2.1.1	Type and Functions	1-5	5	Maintenance by the User	1-26
2.1.2	First Print Time	1-6	5.1	Maintenance Items	1-26
2.1.3	Printing Speed	1-6	5.1.1	Cleaning	1-26
2.1.4	Print Size	1-9	5.1.2	Inspection	1-27
2.1.5	Others	1-10	6	Safety	1-28
2.2	Reader Unit Specifications	1-11	6.1	Safety of the Laser System	1-28
3	Names of Parts	1-12	6.2	Regulations by the Center for Devices and Radiational Heath (CDRH)	1-28
3.1	External View	1-12	6.3	Handling the Laser Assembly	1-29
3.2	Cross Section	1-14	6.4	Safety of Toner	1-30
4	Using the Machine	1-16			
4.1	Turning On the Power	1-16			

CHAPTER 2 BASIC OPERATIONS (AS COPIER)

1 Functional Construction	2-1	3.1 Basic Sequence of Operations at Power-On	2-5
2 Arrangement of Major PCBs	2-2	3.2 Basic Sequence of Operations ...	2-7
3 Basic Sequence of Operations	2-5		

CHAPTER 3 MAIN CONTROLLER

1 Specifications, Control Mechanisms, and Functions	3-1	3.6.5 Flow of Image Data for Fax Reception Functions ...	3-17
2 Basic Operations	3-2	3.6.6 Flow of Image Data for PDL Functions	3-18
2.1 Functional Construction	3-2	4 Disassembly and Assembly	3-19
2.2 Outline of the Electrical Circuitry	3-3	4.1 Removing the Controller Fan	3-19
2.2.1 Outline	3-3	4.2 Removing the Main Controller PCB (main)	3-20
2.2.2 Main Controller PCB	3-3	4.3 When Replacing the Main Controller PCB (main)	3-21
2.3 Startup Sequence	3-5	4.4 Removing the Main Controller PCB (sub)	3-22
2.3.1 Outline	3-5	4.5 When Replacing the Main Controller PCB (sub)	3-23
2.3.2 Startup Sequence	3-6	4.6 Removing the SRAM PCB	3-24
2.3.3 Construction of the System Software	3-7	4.7 Points to Note When Replacing the SRAM PCB	3-25
3 Image Processing	3-8	4.8 Removing the UFR Board	3-26
3.1 Flow of Images	3-8	4.9 Removing the Ethernet Board	3-27
3.2 Construction of the Image Processing Module	3-9	4.10 Removing the Differential PCB	3-28
3.3 Reader Input Image Processing	3-10	4.11 Removing the Power Distribution PCB	3-29
3.4 Compression/Decompression and Edit Processing Block	3-11	4.12 Removing the HDD	3-30
3.5 Printer Output Image Processing	3-12	4.13 After Replacing the HDD	3-31
3.6 Flow of Image Data by Function	3-13	4.13.1 If NetSpot Accountant (NSA) Is Not Used	3-31
3.6.1 Flow of Image Data for Copier Functions	3-13	4.13.2 If NetSpot Accountant (NSA) Is Used Together with a Card Reader	3-31
3.6.2 Flow of Image Data for Box Functions	3-14		
3.6.3 Flow of Image data for SEND Function	3-15		
3.6.4 Flow of Image Data for Fax Transmission Functions	3-16		

CHAPTER 4 INSTALLATION

1	Selecting the Site	4-1	3.1	Preparing for Relocation	4-41
2	Unpacking and Installation	4-4	4	Installing the Card Reader-D1	4-42
2.1	Points to Note Before Starting the Work	4-4	4.1	Checking the Contents	4-42
2.2	Unpacking and Removing the Fixing Materials	4-5	4.2	Installation Procedure	4-42
2.3a	Installing the Reader Unit	4-8	4.3	Making Settings If Net Spot Accountant (NSA) Is Used	4-45
2.3b	Connecting the Reader Unit	4-21	5	Installing the NE Controller-A1	4-46
2.4	Mounting the Transfer Cleaning Unit	4-23	6	Installing the Original Tray	4-55
2.5	Fitting the Toner Container	4-25	6.1	Checking the Contents	4-55
2.6	Fitting the Drum Unit	4-27	6.2	Installation Procedure	4-55
2.7	Setting Up the Cassette	4-31	7	Installing the Key Switch Unit-A1 ...	4-57
2.8	Connecting to the Network	4-33	7.1	Checking the Contents	4-57
2.9	Checking the Connection to the Network	4-33	7.2	Installation Procedure	4-57
2.9.1	Using the PING Command	4-33	7.3	Making Checks After Installation	4-59
2.9.2	Making a Check Using a Remote Host Address	4-34	8	Installing the Anti-Condensation Heater	4-60
2.10	Troubleshooting the Network	4-34	8.1	Checking the Contents	4-60
2.10.1	Checking the Connection of the Network Cable	4-34	8.2	Installation Procedure	4-61
2.10.2	Making a Check Using a Loopback Address	4-35	9	Installing the Cassette Heater Kit-A1	4-72
2.10.3	Making a Check Using a Local Host Address	4-35	9.1	Checking the Contents	4-72
2.11	Checking the Images/ Operations	4-36	9.2	Installation Procedure	4-74
2.11.1	PASCAL Setting	4-40	9.2.1	Installing the Cassette Heater Kit to a Copier	4-75
3	Relocating the Machine	4-41	9.2.2	Installing the Cassette Heater Kit to a 2-Cassette Pedestal-X1	4-78
			10	Replacing the Drum Unit	4-79
			10.1	Preparing for the Work	4-79
			10.2	Installation Procedure	4-81

CHAPTER 1

INTRODUCTION

1 System Construction

1.1 System Construction of the Pickup/Delivery Options

A system may be configured as follows:

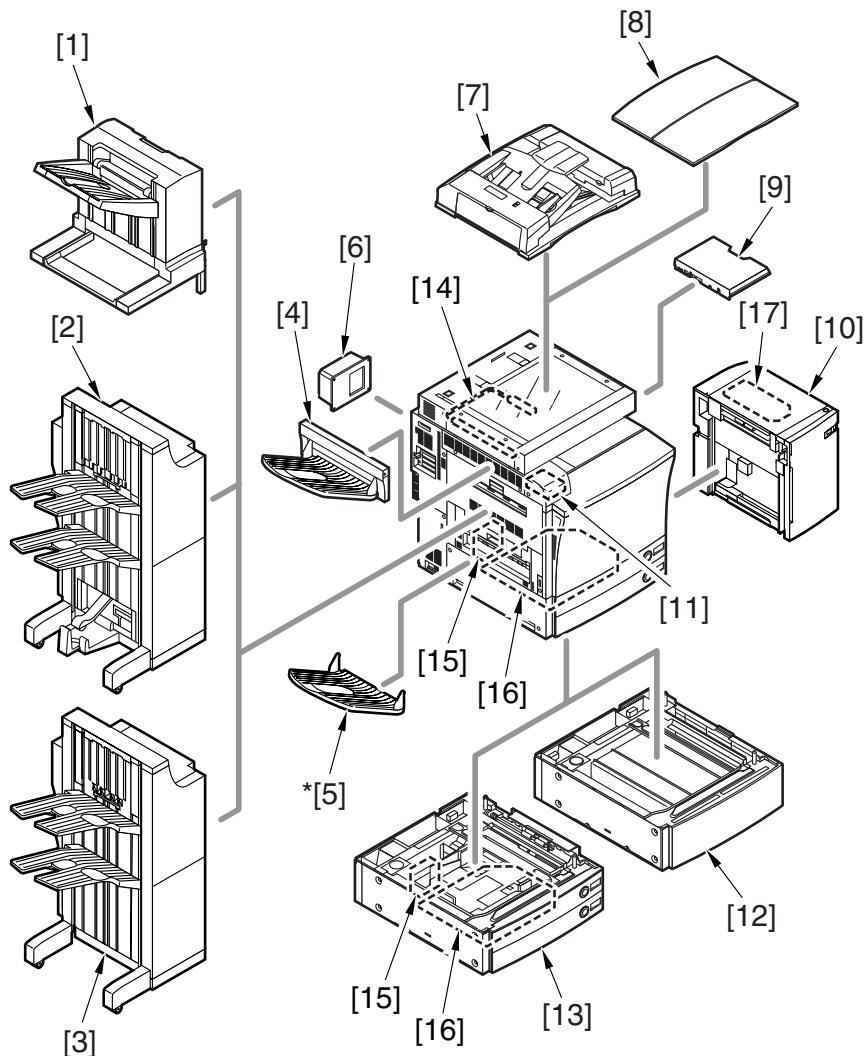

- | | |
|------------------------------|--|
| [1] Finisher-M1 | [10] Slide Paper Deck-P1 |
| [2] Saddle Finisher-N2 | [11] Card Reader-D1 |
| [3] Finisher-N1 | [12] Plain Pedestal-C1 |
| [4] Copy Tray-H1 | [13] 2-Cassette Pedestal-X1 |
| [5] Delivery Tray (standard) | [14] Anti-Condensation Heater (100/230V) |
| [6] NE Controller-A1 | [15] Cassette Heater Kit-A1 |
| [7] DADF-K1 | [16] Cassette Heater Unit-24 |
| [8] Copyboard Cover | [17] Cassette Heater Unit-25 |
| [9] Original Tray | |

*The presence of any of [1] through [3] prevents installation of [4] and [5].

F01-101-01

1.2 System Construction of Printing/Communications Options

A system may be configured as follows:

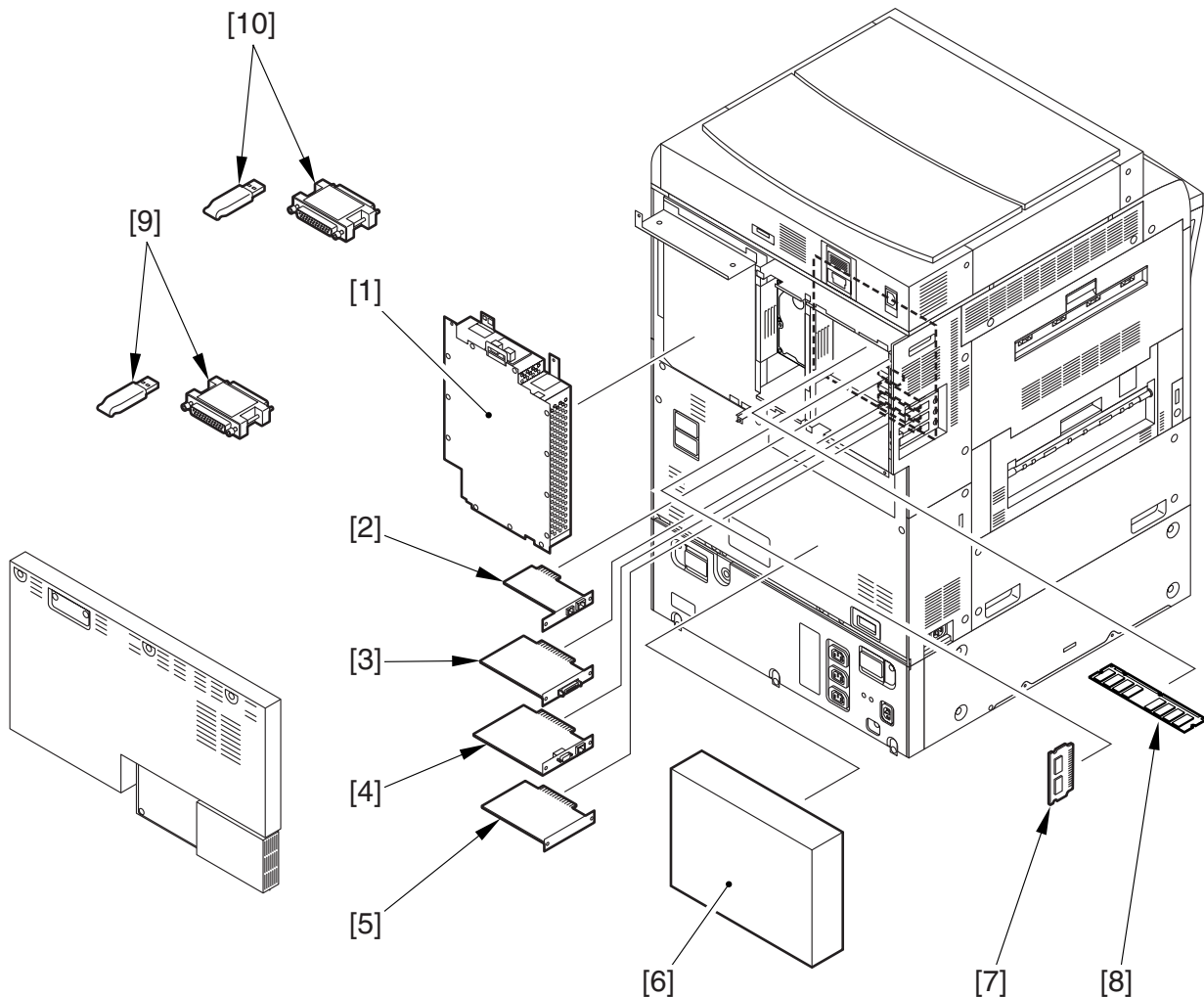

- [1] Super G3 FAX Board-M1
- [2] Ethernet Board (standard)
- [3] UFR Board or Open Interface Board
- [4] USB Interface Board or TokenRing Board
- [5] Resolution Switching Board-A1
- [6] PS Print Server Unit
- [7] PDL Expansion Kit (LIPS)-A1 (boot ROM for LIPS model: 100V model only)
- [8] Color iR2568MB Expansion RAM (option if 100V model)
- [9] Color Universal Send Kit-A1P/A1U (dongle for functional expansion)
- [10] iR Security Kit-A1P/A1U (dongle for functional expansion)

F01-102-01

1.3 Functions of Print/Communication Options

The print/communication options offer the following functions:

	GDI-UFR print function	SEND function	Fax function	Local print function	Token Ring network print function
UFR Printer and Scanner Kit-A1	○*	—	—	○*	○*
Color Universal Send Kit-A1P/A1U	—	○	—	—	—
Resolution Switching Board-A1	—	○	○	—	—
USB Interface Board-A1	—	—	—	○	—
Super G3FAX Board-M1	—	—	○	—	—
Token Ring Board	—	—	—	—	○

*If an iR C3200N (GDI-UFR model), comes as standard.

T01-103-01

1.4 Outline of the Print/Communication Options

The following is an outline of individual options. For details, see the pages that follow:

1.4.1 UFR Printer and Scanner Kit-A1

It adds GDI-UFR print functions and scan functions from ScanGear.

1.4.2 Color Universal Send Kit-A1P/A1U

It adds communication functions. A PC will be needed for setup work. Select A1P (using the parallel port of the PC) or A1U (using the USB port of the PC) to suit the type of PC.

1.4.3 Resolution Switching Board-A1

It is required when communication/fax functions are added.

1.4.4 USB Interface Board-A1

A PC may be connected (USB) locally to add print functions. It requires a UFR board.

1.4.5 Super G3 FAX Board-M1

It adds G3 fax functions.

1.4.6 Token Ring Board

A PC may be connected (Token Ring) network to add print function.

2 Product Specifications

2.1 General Specifications (including printer unit)

2.1.1 Type and Functions

Reader unit	Flat-bed	
Printer unit	Desk-top	
Photosensitive medium	OPC drum	30.6 mm dia. (4 pc.)
Method of charging	Laser exposure	
Method of charging	Roller charging	
Method of development	Monochrome	Dry, 2-component
	Color	Dry, 2-component
Method of pickup	Cassette	Separation retard
	20	21
Method of transfer	Intermediate transfer belt	
	primary transfer: by charging roller	
	secondary transfer: by charging roller	
Method of separation	Curvature separation (static eliminator)	
Method of cleaning	Drum	None
	Transfer belt	Blade
		(equalizing operation used)
Method of fixing	Roller fixing	
Method of delivery	Face-down, face-up	
Warm-up time	At power-on	6 min or less
		(at 20°C room temperature)
	Return from low-power mode	30 sec (Bk mode only)
Print area	Maximum image guarantee area	301 × 452 mm
	Maximum print area	305 × 452 mm
Print resolution	9600 dpi (equivalent) × 600 dpi	
Toner level detection	Yes	
Delivery assembly condition (full) detection	yes (face-down delivery only)	
Jam detection	Yes	
Counter	Yes	
Paper thickness auto detection	None	
Cassette paper present/level detection	Yes	
Toner container detection/drum unit detection	Yes	
(toner container/drum unit)	Yes	
Consumption detection		
Option	See "System Construction."	

T01-201-01

2.1.2 First Print Time

	Unit: sec	
	Full-color	Monochrome
A4, plain (64 g/m ² to 105 g/m ²)	12.8	9.5

T01-201-02

2.1.3 Printing Speed

- Plain Paper Mode (64 g/m² to 105 g/m²)

Paper size	unit: prints/min				
	Cassette, single-sided	Manual feeder, single-sided	Side paper deck, single-sided	Face-down, double-sided	Face-up, double-sided
B5	32	19	32	13.5	10.25
A5R	16	16	–	8	8
A4	32	19	32	13.5	10.25
STMT-R	16	16	–	8	8
LTR	32	19	32	13.5	10.25
B5R	16	16	–	7.5	7
LTR-R	16	16	–	7.5	7
A4R	16	16	–	7.5	7
LGL	16	14	–	6.5	5.5
B4	16	14	–	6.5	5.5
A3	16	13	–	6.5	5.5
279 mm × 432 mm (11 × 17)	16	13	–	6.5	5.5
305 mm × 457 mm (12 × 18)	15	13	–	6.5	5.5
A5	–	16	–	–	–
320 mm × 450 mm (12.6 × 17.7)	–	13	–	–	–

T01-201-03

- Thick Paper Mode (more than 105 g/m²)

unit: prints/min

Paper size	Cassette, single-sided	Manual feeder, single-sided	Side paper deck, single-sided	Face-down, double-sided	Face-up, double-sided
B5	16	9.5	16	6.75	5.13
A5R	16	9.5	–	6.75	5.13
A4	16	9.5	16	6.75	5.13
STMT-R	16	9.5	–	6.75	5.13
LTR	16	9.5	16	6.75	5.13
B5R	11	8	–	3.75	3.5
LTR-R	11	8	–	3.75	3.5
A4R	11	8	–	3.75	3.5
LGL	9.5	7	–	3.25	2.75
B4	9.5	7	–	3.25	2.75
A3	8	6.5	–	3.25	2.75
279 mm × 432 mm (11 × 17)	8	6.5	–	3.25	2.75
305 mm × 457 mm (12 × 18)	7.5	6.5	–	3.25	2.75
A5	–	9.5	–	–	–
Jpn postcard	–	9.5	–	–	–
Tab paper	–	9	–	–	–
320 mm × 450 mm (12.6 × 17.7)	–	6.5	–	–	–

T01-201-04

- Color Transparency Film

Paper size	unit: prints/min	
	Cassette, single-sided	Manual feeder, single-sided
B5	—	—
A4	6	6
LTR	6	6
LTR-R	6	6
A4R	6	6

T01-201-05

- Monochrome, transparency

Paper size	unit: prints/min	
	Cassette, single-sided	Manual feeder, single-sided
A4	7	7
LTR	7	7
LTR-R	7	7
A4R	7	7

T01-201-06

2.1.4 Print Size

	Size	Paper type	Remarks
Cassette	A5R, B5, B5R, A4, A4R, B4, A3, 279 mm × 432 mm (11 × 17), 305 mm × 457 mm (12 × 18), LGL, LTR, LTR-R, STMT-R	Thin paper (less than 64 g/m ²), plain paper (64 to 105 g/m ²), thick paper (to 209 g/m ²), recycled paper, transparency film (A4/LTR)	If transparency, single-side only.
Manual feeder	A5R, B5, B5R, A4, A4R, B4, A3, 279 mm × 432 mm (11 × 17), 305 mm × 457 mm (12 × 18), 320 mm × 450 mm (12.6 × 17.7), postcard	Plain paper (64 to 105 g/m ²), thick paper (to 253 g/m ²), recycled paper, transparency (A4/LTR), postcard, bond paper, glossy paper, label paper, rice paper, tracing paper, tab paper, 2-panel postcard, 4-panel postcard	If transparency, rice paper, tracing paper, glossy paper, label paper, tab paper, single-sided only.
Side Paper Deck-P1	B5, A4, LTR	Thin paper (less than 64 g/m ²), plain paper (64 to 105 g/m ²), thick paper (to 209 g/m ²), recycled paper	
2-Cassette Pedestal-X1	A5R, B5, B5R, A4, A4R, B4, A3, 279 mm × 432 mm (11 × 17), 305 mm × 457 mm (12 × 18), LGL, LTR, LTR-R, STMT-R	Thin paper (less than 64 g/m ²), plain paper (64 to 105 g/m ²), thick paper (to 209 g/m ²), recycled paper, transparency (A4/LTR)	
Duplex unit (iR C3200 only)	A5R, B5, B5R, A4, A4R, B4, A3, 279 mm × 432 mm (11 × 17), 305 mm × 457 mm (12 × 18), LGL, LTR, LTR-R, STMT-R	Plain paper (64 to 105 g/m ²), thick paper (to 209 g/m ²), recycled paper, bond paper	Through-path system

T01-201-07

2.1.5 Others

Operation environment	Temperature range	7.5 to 32.5°C
	Humidity range	5 to 90%
	Atmospheric pressure range	810.6 to 1013.3 hpa (0.8 to 1.0 atm)
Operating noise	In operation	71 dB or less
	In standby	56 dB or less
Power supply	100 V	
	120 V	
	230 V	
Power consumption	maximum	1500 W or less
	In standby	48 Wh (reference only)
	In continuous printing	720 Wh (reference only)
Ozone	Maximum	0.05 ppm or less
	Average	0.02 ppm or less
Dimensions	Width (W)	620 mm
	Depth (D)	786 mm
	Height (H)	1040 mm
Weight	Total	118.5 kg (including duplex unit; excluding toner container, drum unit, cable)
	Printer unit	105.5 kg (including duplex unit)

T01-201-08

The descriptions are subject to change for product improvement.

2.2 Reader Unit Specifications

Copyboard	Fixed
Original size detection	Feed sensors, reading CCD; copyboard cover angle
Original type	Sheet, book, 3-D object (2 kg max.)
Maximum original size	A3, 297 mm × 432 mm (11 × 17)
Reproduction ratio	100%, Reduce I (1:0.250), Reduce II (1:0.500), Reduce III (1:0.611), Reduce IV (1:0.707), Reduce V (1:0.816), Reduce VI (1:0.865); Enlarge I (1:1.154), Enlarge II (1:1.224), Enlarge III (1:1.414), Enlarge IV (1:2.000), Enlarge V (1:4.000); Zoom (1:0.250 to 4.000; 25% to 400%: in 1% increments)
Reading resolution	Main scanning direction 600 dpi Sub scanning direction 600 dpi
Number of gradations	256
Reading maximum non-image width	Main scanning direction 0 to 2 mm against 297 mm Sub scanning direction 0 to 2 mm against 420 mm
Warm-up time	At power-on 30 sec or less
Continuous reproduction	999 prints (max.)
Source of light	Xenon lamp
Dimensions	Width (W) 585 mm Depth (D) 543 mm Height (H) 87 mm
Weight	12.5 kg
Option	Anti-condensation heater (100/230V model only)

T01-202-01

The descriptions are subject to change for product improvement.

3 Names of Parts

3.1 External View

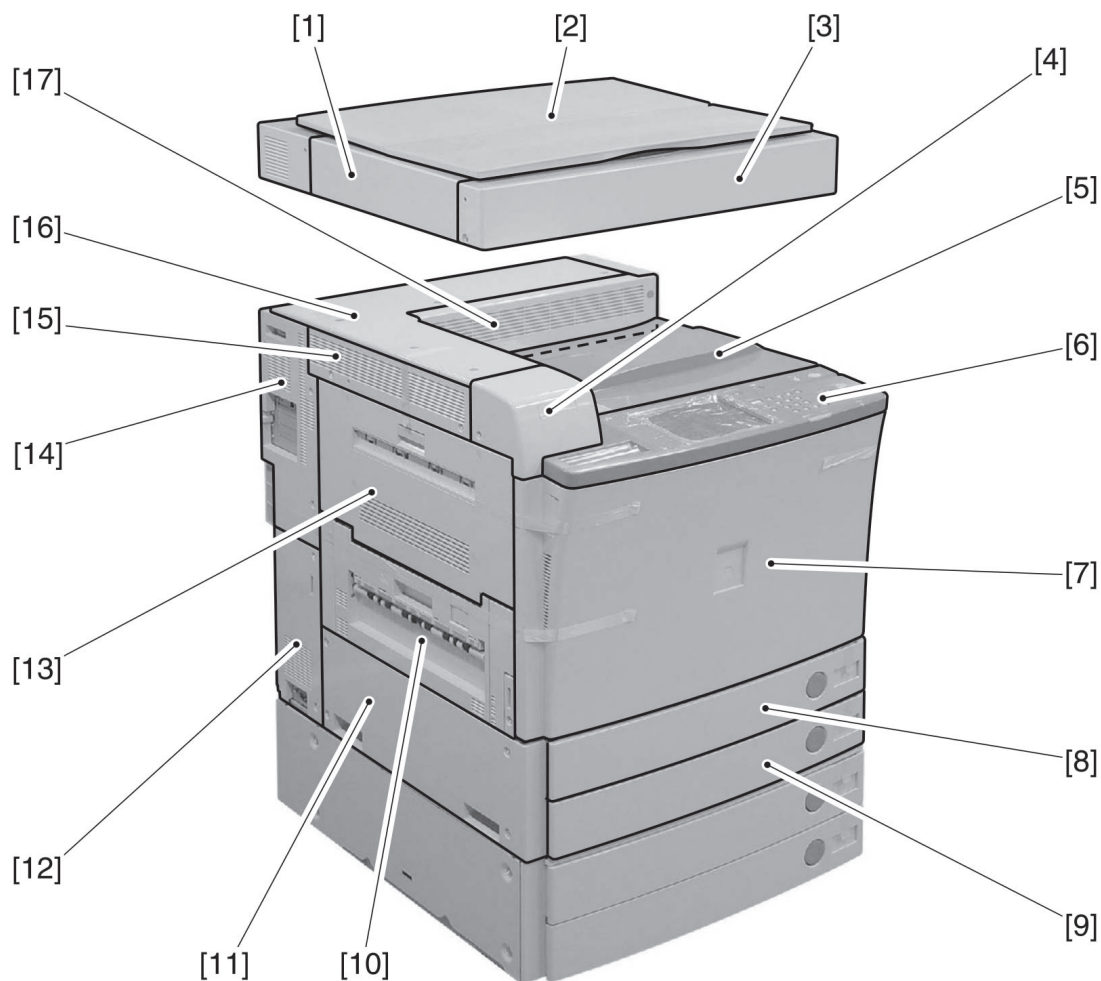

- | | |
|------------------------------|------------------------------|
| [1] Rear left cover | [10] Delivery cover (2) |
| [2] Copyboard cover | [11] Lower left cover |
| [3] Reader front cover | [12] Rear left cover (lower) |
| [4] Upper left cover (small) | [13] Delivery cover (1) |
| [5] Center delivery tray | [14] Rear left cover (upper) |
| [6] Control panel | [15] Upper left cover |
| [7] Front cover | [16] Upper cover |
| [8] Cassette 1 | [17] Inside upper cover |
| [9] Cassette 2 | |

F01-301-01

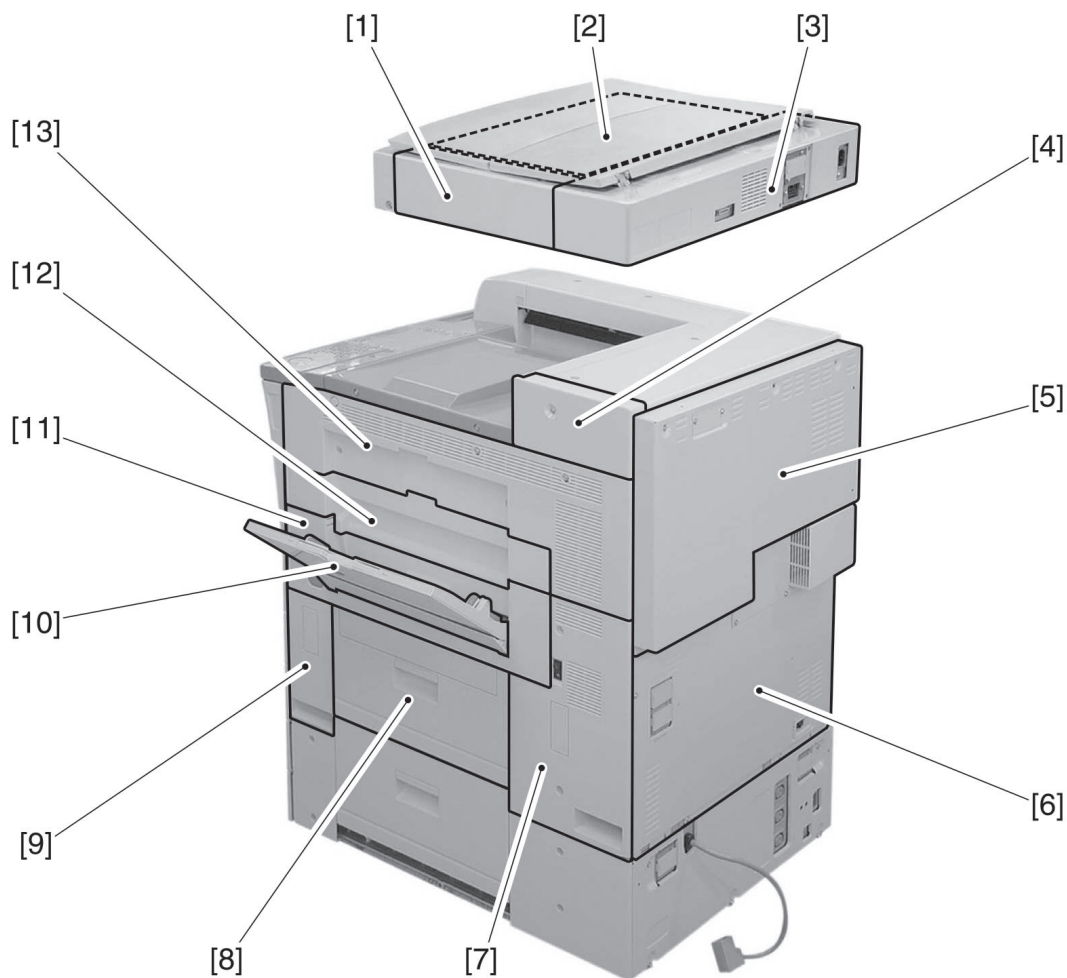

[1] Reader right cover

[2] Copyboard glass

[3] Reader rear cover

[4] Upper right cover (small)

[5] Upper rear cover

[6] Lower rear cover

[7] Rear right cover

[8] Right cover

[9] Front right cover

[10] Manual feed tray

[11] Manual feed unit cover

[12] Model right cover

[13] Upper right cover

F01-301-02

3.2 Cross Section

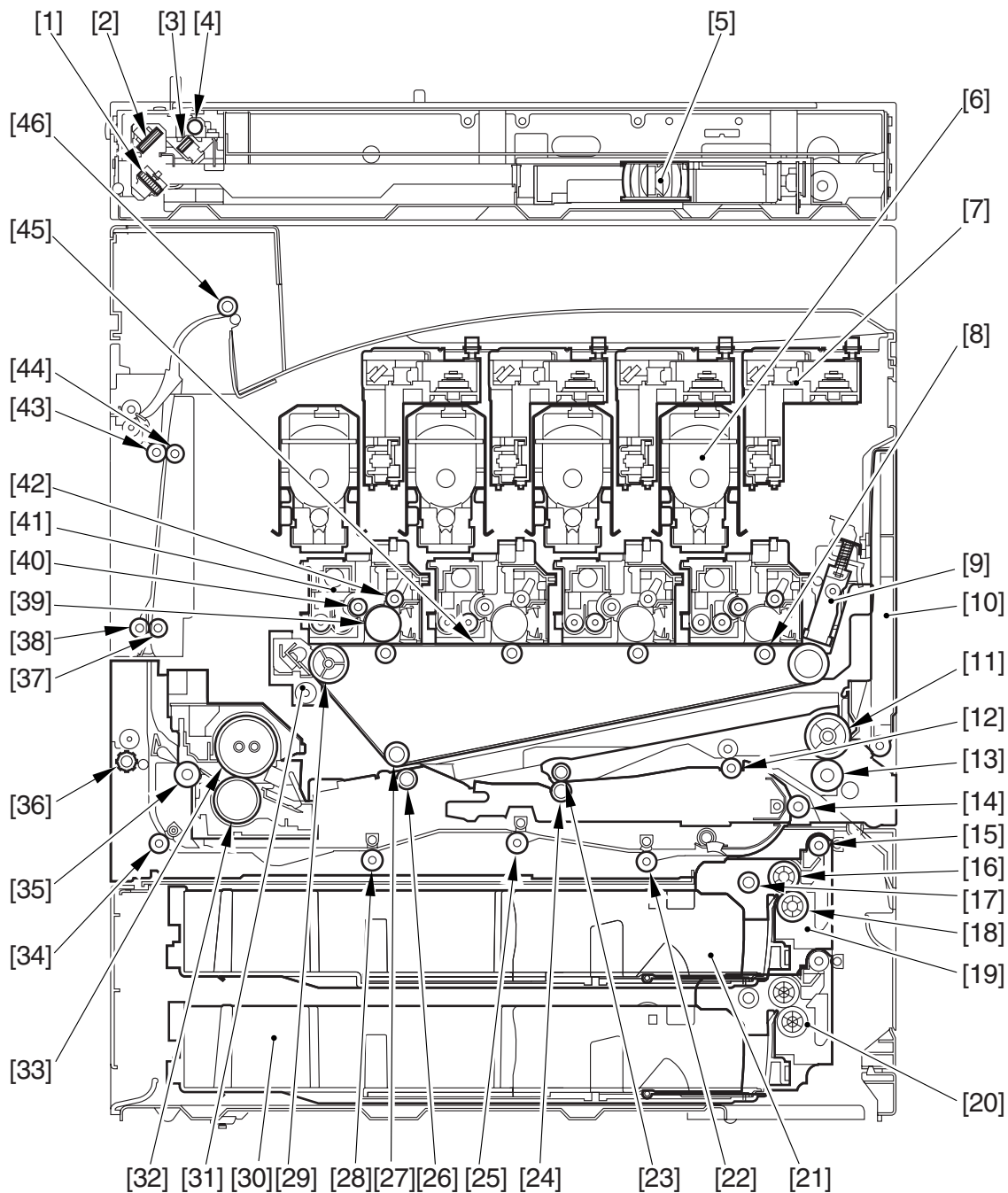

F01-302-01

- [1] No. 3 mirror
- [2] No. 2 mirror
- [3] No. 1 mirror
- [4] Scanning lamp
- [5] CCD unit
- [6] Toner container
- [7] Laser unit
- [8] Primary transfer roller
- [9] Registration detention unit
- [10] Manual feed pickup tray unit
- [11] Manual feed roller
- [12] Pre-registration roller
- [13] Manual feed separation roller
- [14] Re-pick up roller
- [15] Pickup vertical path roller
- [16] Feed roller
- [17] Pickup roller
- [18] Separation roller
- [19] Pickup assembly 1
- [20] Pickup assembly 2
- [21] Cassette 1
- [22] Duplex roller 4
- [23] Registration upper roller
- [24] Registration lower roller
- [25] Duplex roller 3
- [26] Secondary transfer external roller
- [27] Secondary transfer internal roller
- [28] Duplex roller 2
- [29] Intermediate transfer belt tension roller
- [30] Cassette 2
- [31] Transfer cleaning unit
- [32] Fixing lower roller (pressure roller)
- [33] Fixing upper roller (fixing roller)
- [34] Duplex roller 1
- [35] Internal delivery roller
- [36] Face-up delivery roller
- [37] Delivery vertical path clip
- [38] Delivery vertical path roller 2
- [39] Photopositive drum
- [40] Developing cylinder
- [41] Drum unit
- [42] Charging roller
- [43] Delivery vertical path roller 1
- [44] Delivery path clip
- [45] Intermediate transfer belt
- [46] Face-down delivery roller 1

T01-302-01

4 Using the Machine

4.1 Turning On the Power

The machine is equipped with 2 power switches: main power switch and control panel power switch. Normally, the machine is supplied with power when the main power switch is turned on (i.e., other than when it is in power save mode, low power mode, or sleep mode).

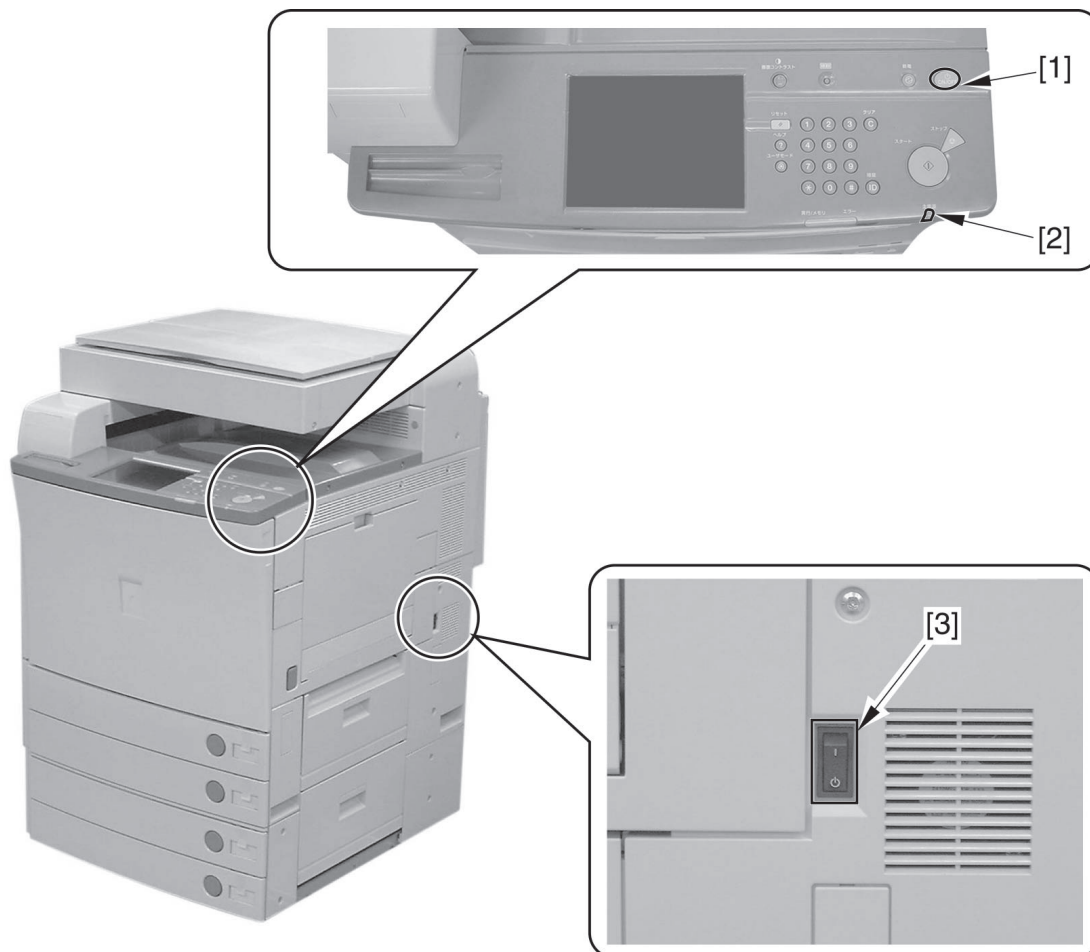

- [1] Control panel power switch
- [2] Main power lamp

- [3] Main power switch

F01-401-01



Never turn off the main power while the progress bar is indicated. (The machine is accessing its HDD.) Otherwise, the HDD can go out of order (E602).

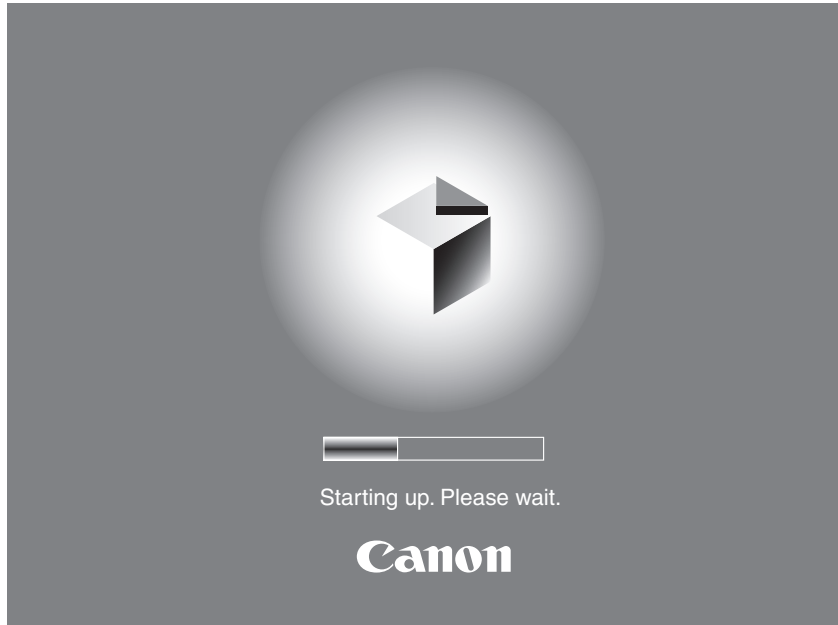

F01-401-02

4.2 Points to Note When Turning Off the Main Power Switch

Be sure to turn off the control panel power switch before turning off the main power switch.



- When the Printer Is in Operation/Fax Data Is Being Sent/Received
Be sure that the Execution/Memory lamp on the control panel is OFF before touching the main power switch. (Otherwise, the data being processed can be lost.)

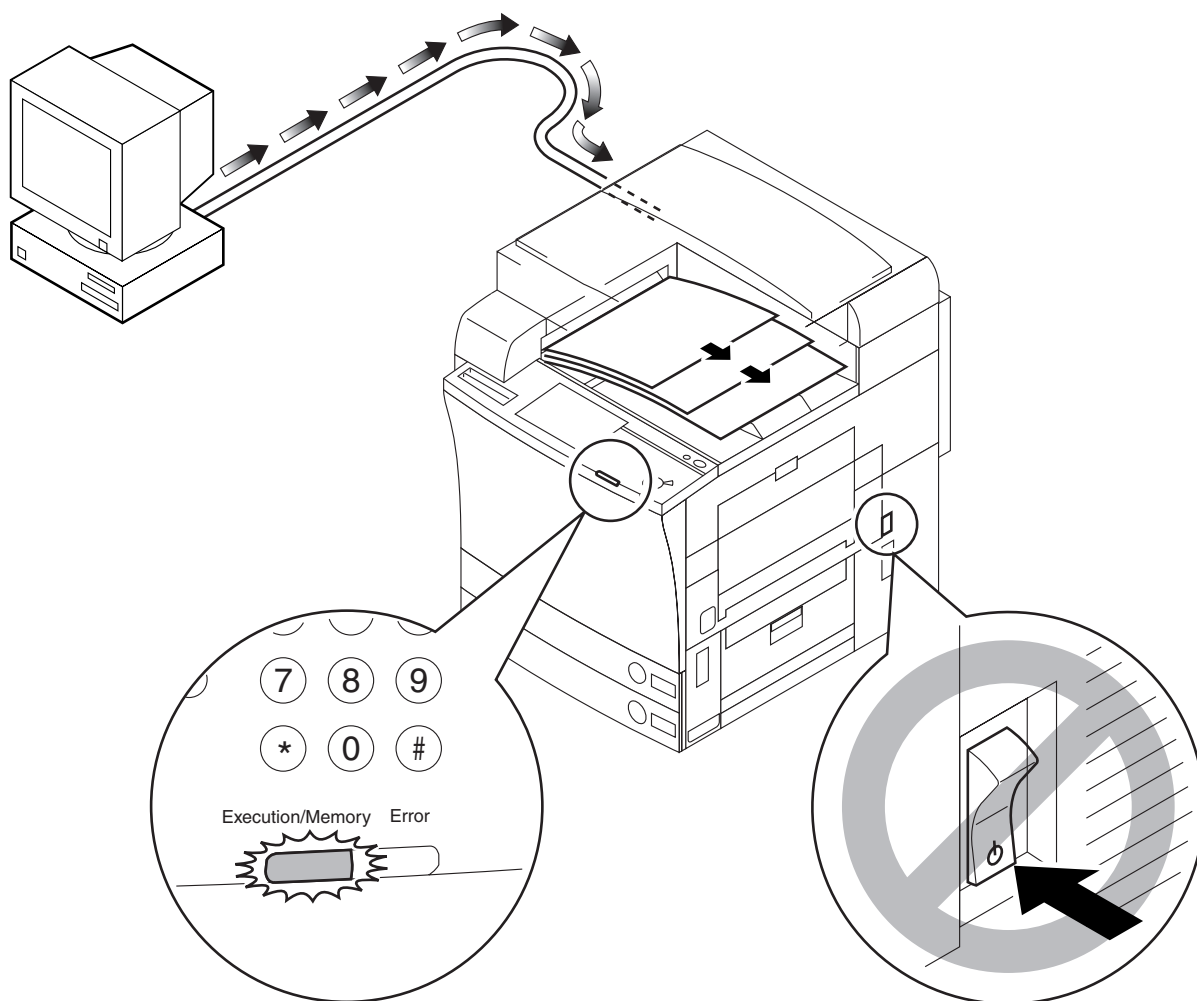

F01-402-01



- **When Downloading Is Under Way**
Never turn off the main power switch or the control panel power switch.
(If you turn off the main power switch while downloading is under way,
the machine may fail to operate.)

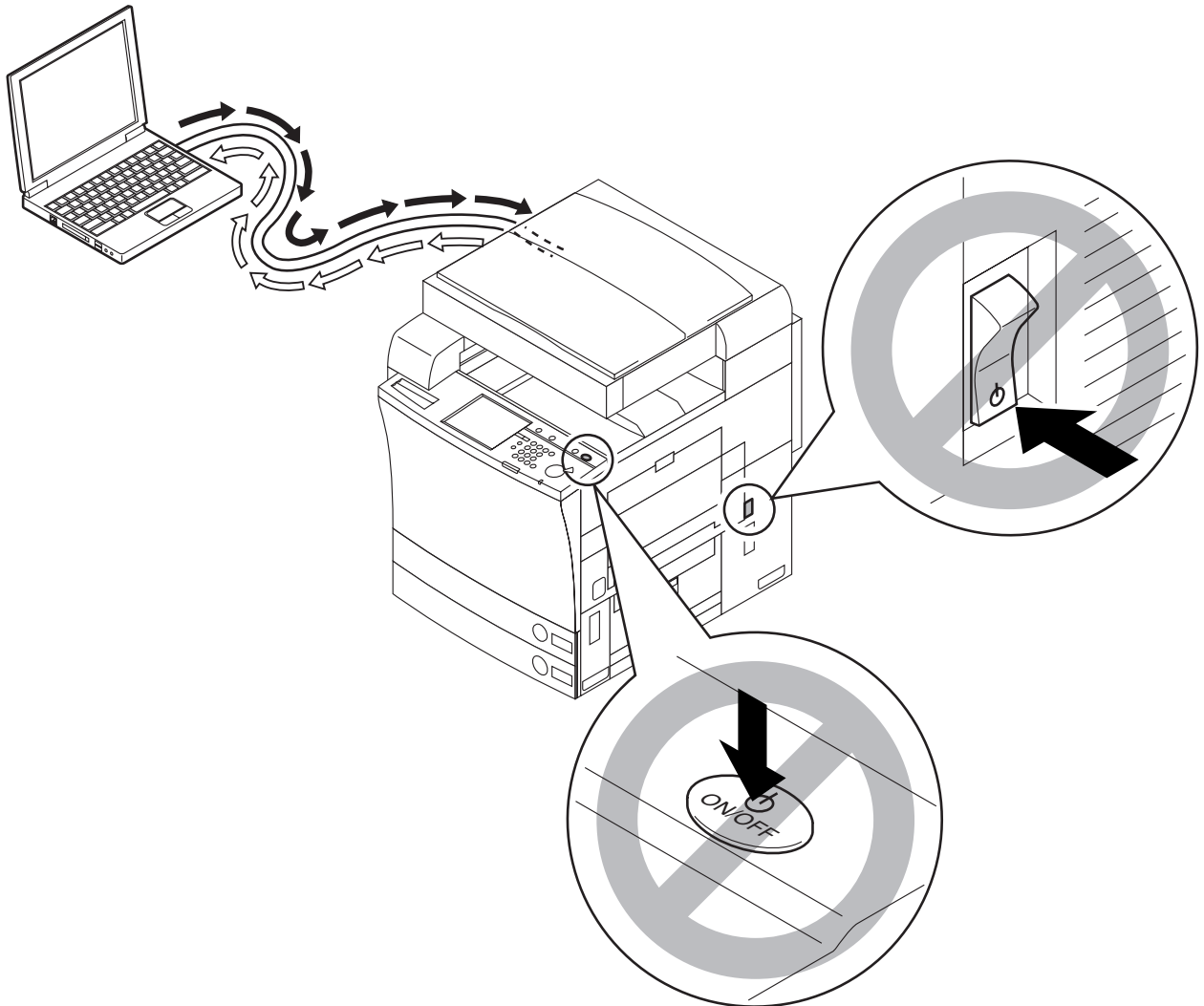

F01-402-02

4.3 Control Panel

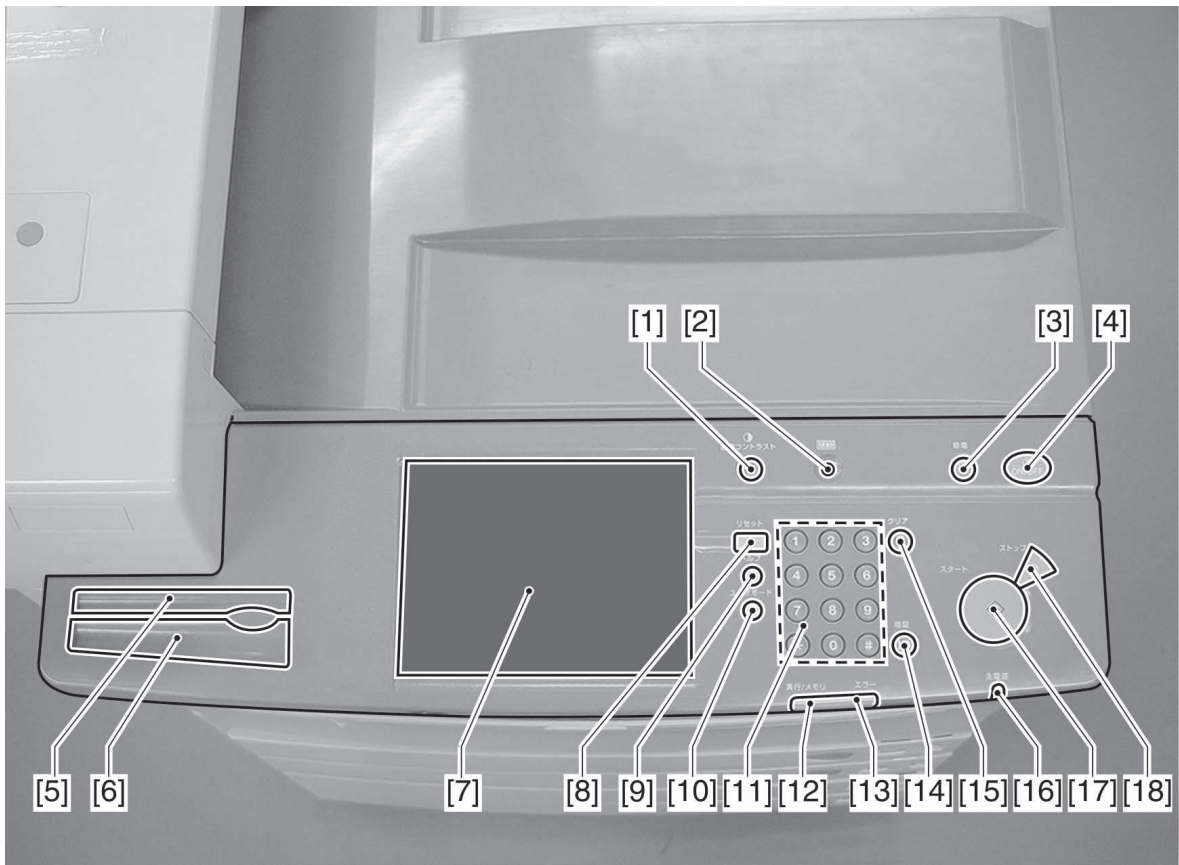

- | | |
|-----------------------------------|--------------------------|
| [1] Image contrast adjusting dial | [10] User mode key |
| [2] Counter check key | [11] Numeric keypad |
| [3] Power Save key | [12] Execute/Memory lamp |
| [4] Control panel power switch | [13] Error lamp |
| [5] Touch pen holder | [14] ID key |
| [6] Paper clip holder | [15] Clear key |
| [7] Touch panel | [16] Main power lamp |
| [8] Reset key | [17] Start key |
| [9] Help key | [18] Stop key |

F01-403-01

4.4 User Mode Items

4.4.1 Common Settings

*Factory default.

Mode	Description
initial functions	*copy, fax, box, SEND
function after auto clear	*return, do not return
enable/disable buzzer	input correct: *ON/OFF input incorrect: ON/*OFF supply alert: ON/*OFF alert: *ON/OFF job end: *ON/OFF residual original: ON/*OFF
priority on text/photo upon selection of auto color	text, *photo
inch input	enable inch input (ON/*OFF; ON if 120 V)
paper type registration upon cassette auto selection	copier, printer, box, fax, other
registration paper type	yes
change power save mode	*10%/25%/50%, immediate recovery
power consumption in sleep state	*little, much
select special tray	use finisher tray for: copier, box, printer, fax, other
priority on print	copy: *1, 2, 3; printer: 1, *2, 3; fax/box/other: 1, 2, *3
register standard mode for manually fed paper	enable/disable standard mode for manually fed paper (ON/*OFF)
standard mode for local print	paper select, print count, sorter, double-sided print, file delete after print, print merge
switch language of display	ON/*OFF
reverse screen color	ON/*OFF
between-jobs shift	*ON/OFF
JPEG compression rate at remote scan	high, *average, low
gamma value at remote scan	γ 1.0/ γ 1.4/* γ 1.8/ γ 2.2
initialize common settings	*yes, no

T01-404-01

4.4.2 Timer Settings

*factory settings.

Mode	Description
set date/time	if fax is installed (10-digit number)
auto sleep time	10 min, *15 min, 20 min, 30 min, 40 min, 50 min, 1 hr, 90 min, 2 hr to 4 hr
change auto clear time	0: none; 1 to 9 min (*2 min)
set weekly timer	00:00 to 23:59 (1-min increments)
shift to low-power consumption mode	10 min, *15 min, 20 min, 30 min, 40 min, 50 min, 1 hr, 90 min, 2 hr to 4 hr

T01-404-02

4.4.3 Adjustments and Cleaning

*factory settings.

Mode	Description
zoom fine adjust	-1.0 to +1.0%: 0.1% intervals, *0%
center binding staple edging	yes
center binding position change	yes
auto gradation correction	PASCAL
density correction	5 settings each for dark and light
cleaning inside machine	yes
cleaning of feeder	yes

T01-404-03

4.4.4 Report Generation

*factory settings.

Mode	Description
transmission (specifications setting)	transmission results report (*only if error, ON, OFF) communications control report
fax (specifications setting)	fax transmission results report (*only if error, ON, OFF) fax communications control report fax reception results report (only if error, ON, *OFF) fax box reception report (*ON, OFF)
transmission (list print)	destinations list user data list
fax (list print)	user data list
network (list print)	user data list

T01-404-04

4.4.5 System Control Settings

*factory settings.

Mode	Description
set system administrator info	yes
group ID control	register ID, control count
set communication control	fax settings, system box settings
enable/disable remote UI	*ON/OFF
limit destinations list	ID in destinations table, access No. in destinations table
set device info	yes
set network	TCP/IP settings SMB settings SNMB settings special port settings (*ON/OFF) spool function (ON/*OFF) start-up time settings (0 to 300 sec; *1 sec) Ethernet driver settings
set transfer	yes
auto online/offline shift	auto online shift (ON/*OFF) auto offline shift (ON/*OFF)
register to LDAP server	yes
switch limits to functions with control key at OFF	*partial limits, entire limits

T01-404-05

4.4.6 Copier Specifications Settings

*factory settings.

Mode	Description
set preference key 1/2	w/ function, *no settings
auto sort	*ON/OFF
priority on image orientation	w/o functions (not possible as orientation changes between single-sided and double-sided)
indicate copy wait time	ON/*OFF
enable auto vertical/horizontal rotation	*ON/OFF
change standard mode	register/initialize
initialize copier specifications settings	Yes, No

T01-404-06

4.4.7 Transmission/Reception Specifications Settings

*factory settings.

Mode	Description
set transmission functions (common settings)	register sending party name (100 max.) register user abbreviation clear error file (*ON/OFF) process transfer error file (print always, store/print, *OFF) change standard mode for transmission functions register default task button set initial display of transmission screen (default task button, one-touch button, *new destination) record source of transmission (*attach, do not attach) initialize transmission function settings
set reception function (common settings)	record double-sided (ON/*OFF) select cassette reduce image (*ON/OFF) record reception info (attach, *do not attach) record 2-on-1 (ON/*OFF)
basic registration (fax settings)	register user telephone No. select line type adjust sound volume
set transmission function (fax settings)	ECM transmission (*ON/OFF) pause length (1 to 15 sec; *2 sec) auto redial (*ON/OFF)
set up transmission functions (fax settings)	ECM reception (*ON/OFF)

T01-404-07

4.4.8 Box Specifications Settings

Mode	Description
set up/register user box	register/set up box (100 max.)
set standard mode for reading	register, initialize
set/register fax box	register/set box (50 max.)

T01-404-08

4.4.9 Printer Specifications Settings

*factory settings.

Mode	Description
set specifications	number of copies (1 to 2000: *1) double-sided (double-sided, *single-sided) print adjustment layout (bind position, bind margin, vertical position, horizontal position) secured print deletion time (1 hr, 2 hr) timeout (*timeout time, disable) post-RIP print (yes, *no) sort (no, shift group, shift sort, staple sort) transparency interleaf (*disable, use blank paper, use print paper)
set reception function (common settings)	color mode (*auto switchover, full-color, monochrome) set gradation select intermediate tone compression image output (*output, error indication) initialize printer settings
utility	initialize printer

T01-404-09

4.4.10 Destinations Table Specifications Settings

Mode	Description
register destination	yes
register name of destination	yes
register one-touch button	yes

T01-404-10

5 Maintenance by the User

5.1 Maintenance Items

5.1.1 Cleaning

- Face of Copyboard Glass, Back of Copyboard Cover

Instruct the user to clean the face of the copyboard glass and the back of the copyboard cover at least once a month.

Cleaning Procedure

Using a cloth moistened with water or solution of mild detergent (well-wrung), clean the face of the copyboard glass [1] and the back of the copyboard cover [2]; then, dry wipe the surfaces.

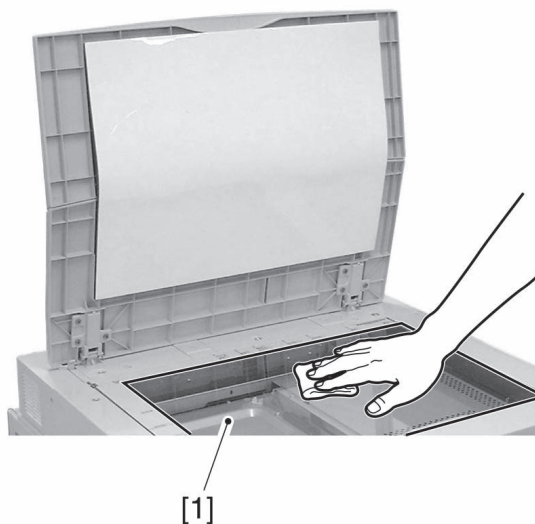

F01-501-01-01

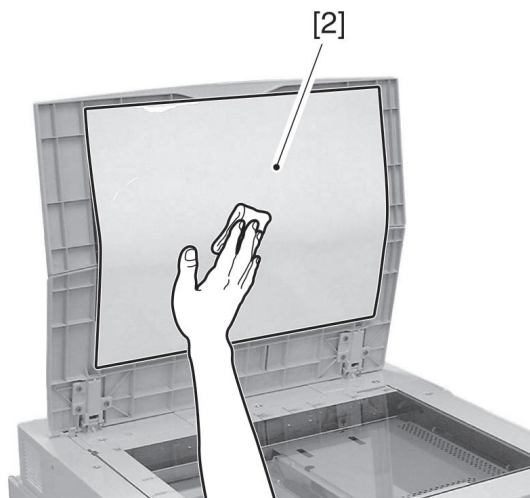

F01-501-01-02

5.1.2 Inspection

- Checking the Leakage Breaker

Instruct the user to check the leakage breaker periodically (once or twice a month), and keep a record of the work.

Inspection Procedure

- 1) Turn on the main power switch.
- 2) Press the test button [1] of the breaker with the tip of a ball-point pen [2] or the like.
- 3) Check to see that the breaker is switched to the OFF side and the power goes OFF.

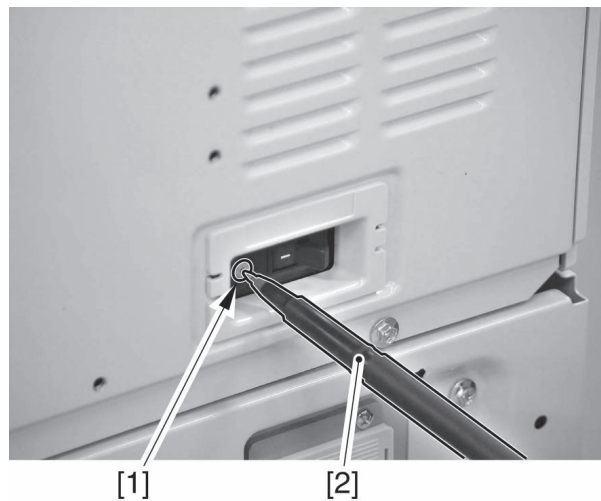

F01-501-02

- 4) Turn off the main power switch.
- 5) Shift the breaker switch [1] to the ON side.

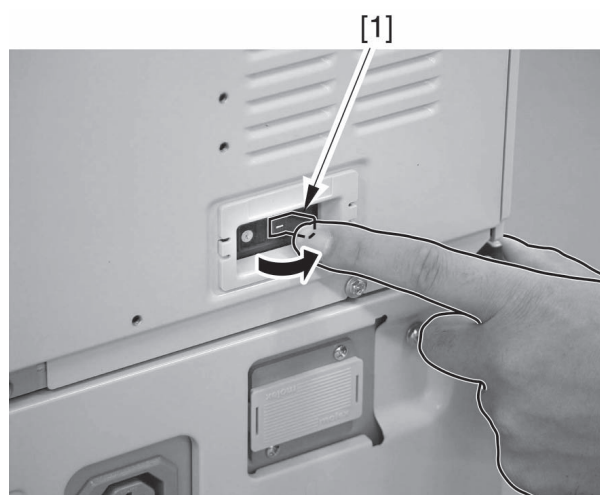

F01-501-03

- 6) Turn on the main power switch.

6 Safety

6.1 Safety of the Laser System

Laser Light in General

Laser light can prove to be very harmful to the human body, requiring full care.

About the Machine's Laser System

The machine's laser optical system is sealed inside a protective housing and external covers, and the machine is constructed to prevent leakage of laser light outside it. As such, the light cannot escape the machine as long as the machine is used for the operations for which it is designed.

6.2 Regulations by the Center for Devices and Radiational Heath (CDRH)

The Center for Devices and Radiation Heath (CDRH) of the United States put into effect regulations drawn up for laser products. These regulations apply to laser products that are produced on August 1, 1976, and thereafter, and ban the sale of laser products without certification indicated by a label obtained from the organization.

6.3 Handling the Laser Assembly

Points to Note When Servicing the Area Around the Laser Optical System

- Do not put an object with a high reflectance (e.g., screwdriver) into the path of the laser light.
- Do not wear a watch or ring during work. (They can reflect the laser light, causing damage to your eyes.)

The machine's laser light is red in color, and the covers that can reflect the light are identified with a label [1]. Pay special attention whenever servicing an area behind these covers.

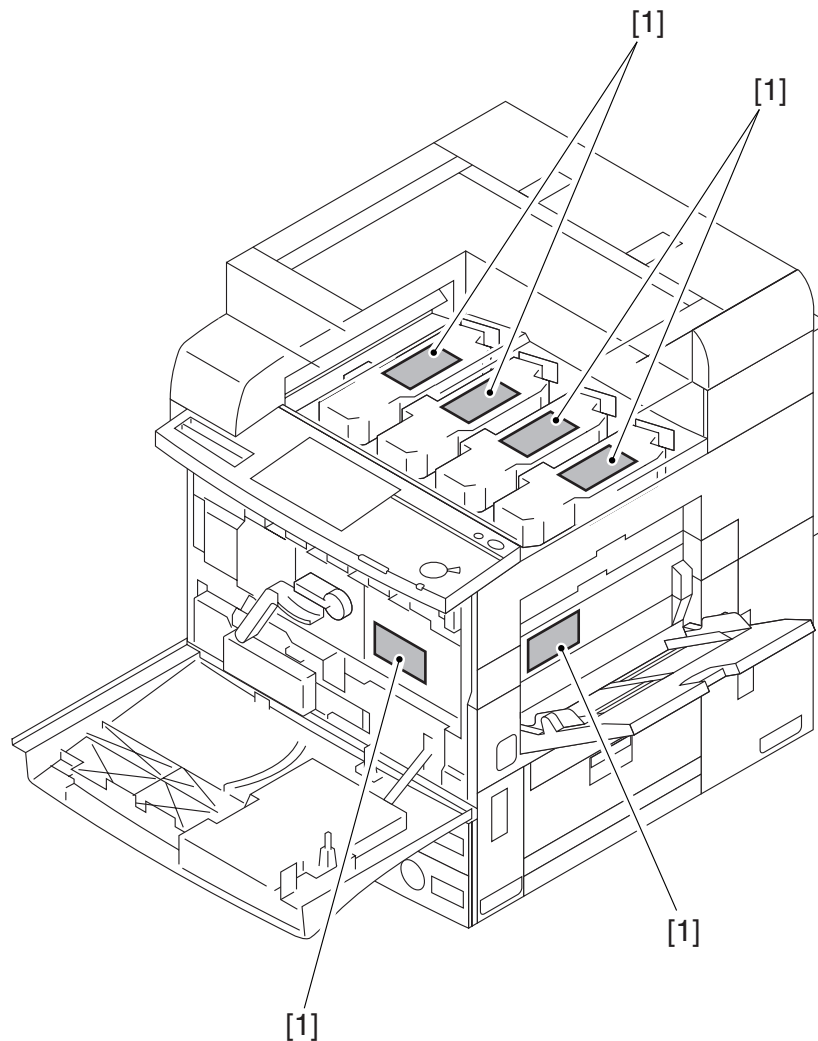

F01-603-01

6.4 Safety of Toner

About the Machine's Toner

The machine's toner is non-toxic, consisting of plastic and iron materials with a few amount of dye.



Do not throw toner into fire. It can explode.

Toner Stains

1. If your skin or clothing has come into contact with toner, remove it with dry tissue, and then wash with water.
2. Do not use warm water; otherwise, the toner will become jell-like, permanently fusing with the fibers of the cloth and resisting removal.
3. Do not bring toner into contact with vinyl material, as they can easily react.

CHAPTER 2

BASIC OPERATIONS (AS COPIER)

1 Functional Construction

The machine can broadly be divided into the following functional blocks:

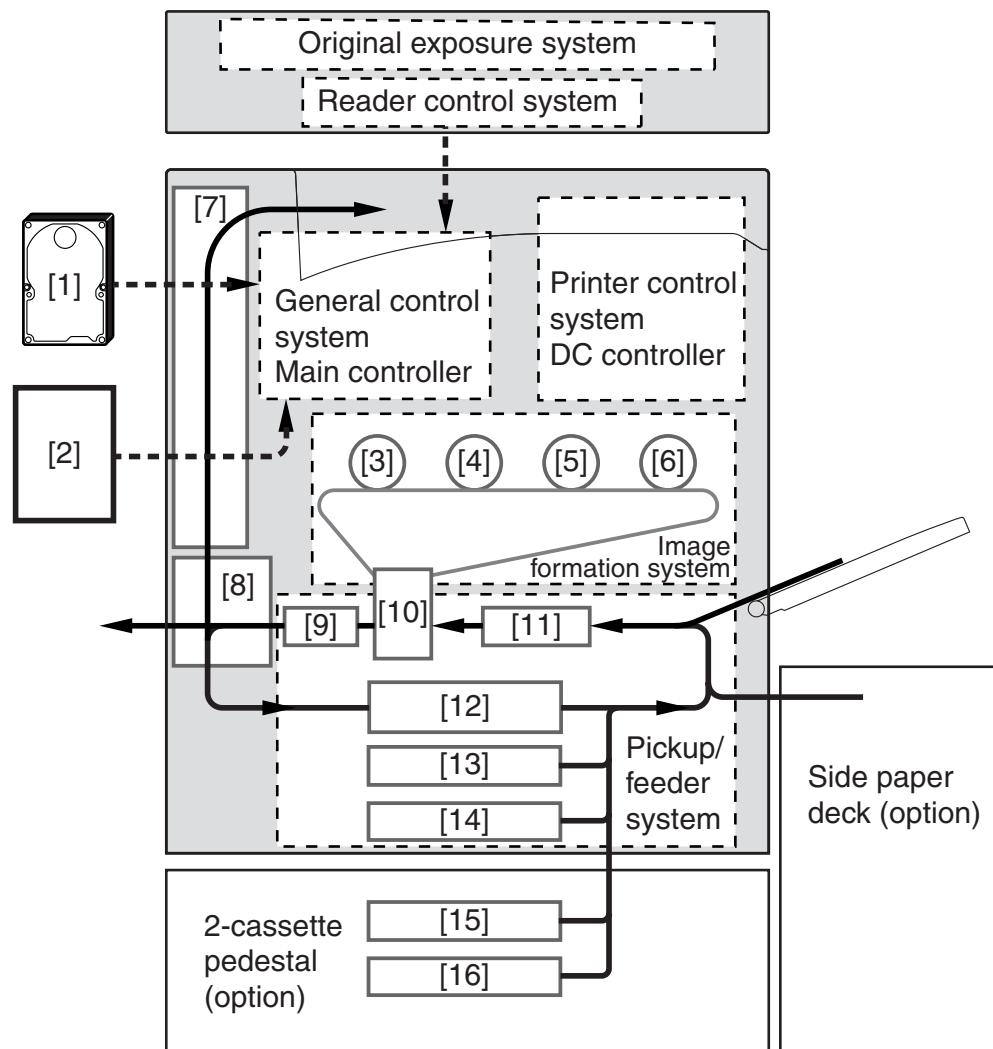



- | | |
|------------------------------|---------------------------|
| [1] HDD | [9] Feeder system |
| [2] Option boards | [10] Transfer system |
| [3] Photosensitive drum (Y) | [11] Pickup control |
| [4] Photosensitive drum (M) | [12] Duplex feeder system |
| [5] Photosensitive drum (C) | [13] Cassette 1 |
| [6] Photosensitive drum (Bk) | [14] Cassette 2 |
| [7] Delivery system | [15] Cassette 3 |
| [8] Fixing system | [16] Cassette 4 |

F02-100-01

2 Arrangement of Major PCBs

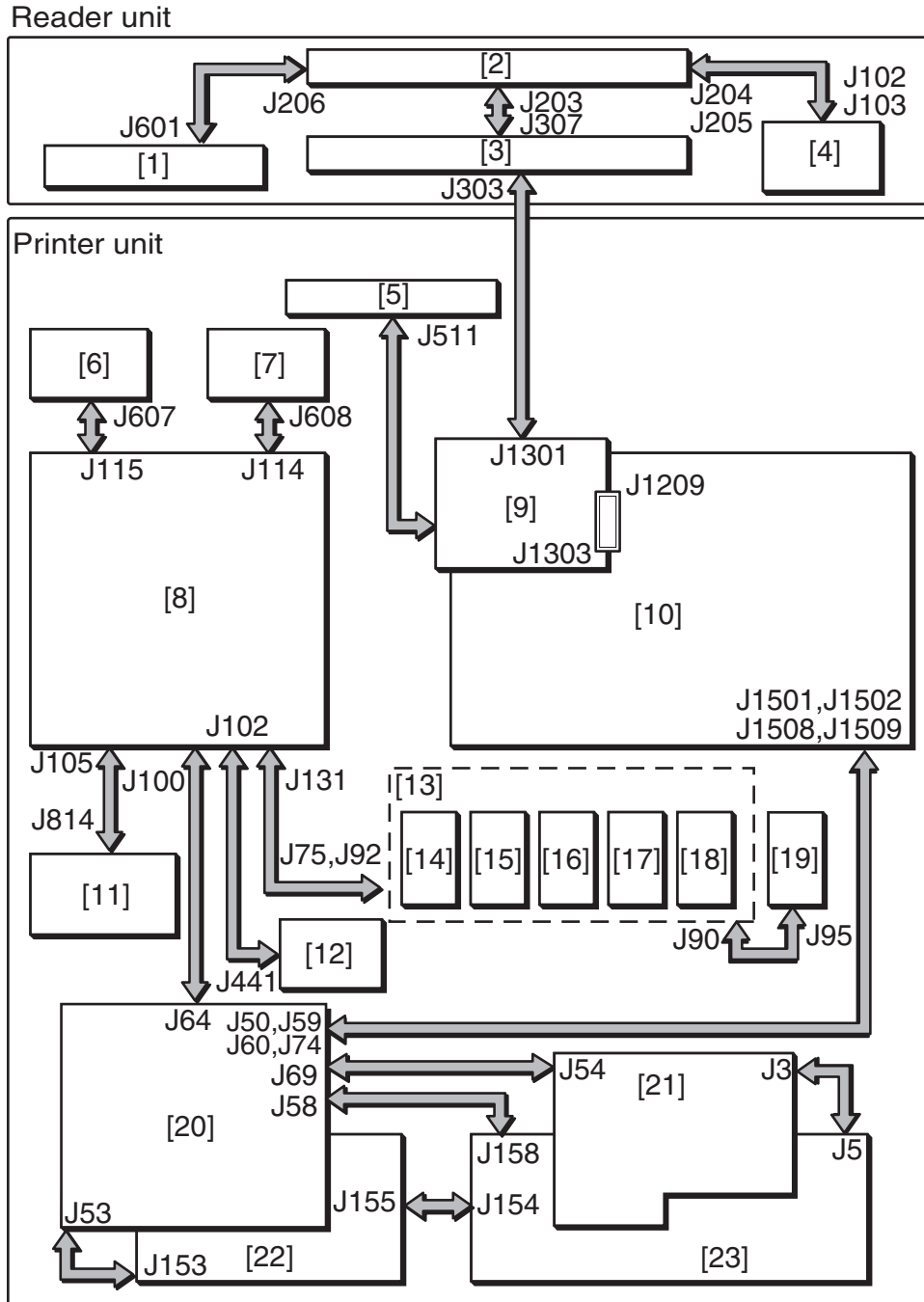
The machine's major PCBs are wired as indicated in the following diagram:



-  flat cable.
-  PCB-to-PCB connector.

F02-200-01

- | | |
|---------------------------------|------------------------------|
| [1] Inverter PCB | [13] High-voltage unit |
| [2] Reader controller PCB | [14] HV1 PCB |
| [3] Interface PCB | [15] HV1-SUB PCB |
| [4] CCD/AP PCB | [16] HV2 PCB |
| [5] Control panel CPU PCB | [17] HV2-SUBY PCB |
| [6] BD detection PCB | [18] HV4 PCB |
| [7] Laser driver PCB | [19] HV3 PCB |
| [8] DC controller PCB | [20] Fuse PCB |
| [9] Main controller PCB (sub) | [21] Heater control PCB |
| [10] Main controller PCB (main) | [22] DC power supply PCB (1) |
| [11] Drum ITB motor | [23] DC power supply PCB (2) |
| [12] Duplex driver PCB | |

T02-200-01



The symbol \Leftrightarrow in the diagram indicates major wiring connections, and does NOT indicate the direction of signals.

The major PCBs within the machine's main controller are connected as follows:

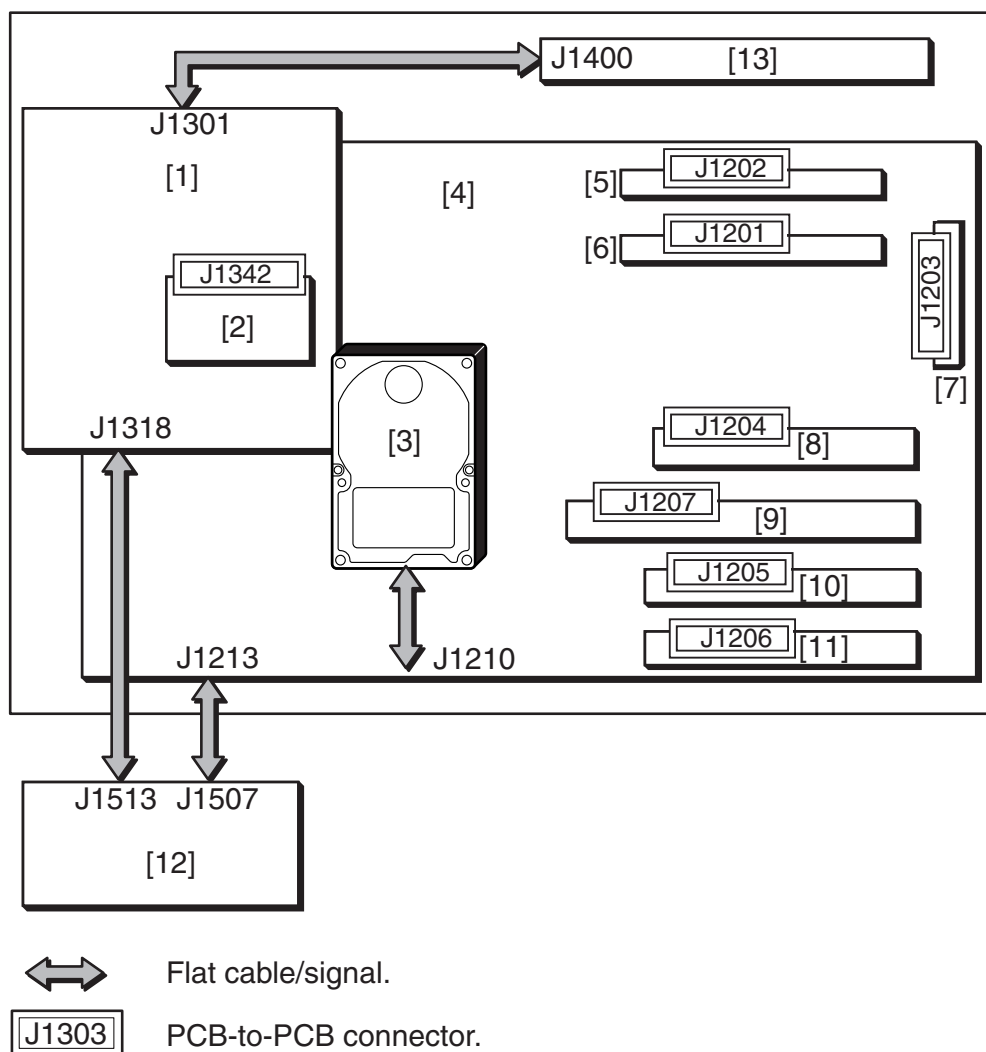

- | | |
|--------------------------------|---|
| [1] Main controller PCB (sub) | [8] Ethernet board |
| [2] SRMA PCB | [9] UFR board or Open interface board |
| [3] HDD | [10] USB interface board or TokenRing board |
| [4] Main controller PCB (main) | [11] Image conversion board |
| [5] 512-MB expansion RAM | [12] Power distribution PCB |
| [6] 256-MB expansion RAM | [13] Differential PCB |
| [7] Boot ROM | |

F02-200-02



The symbol \Leftrightarrow used in the diagram indicates connection between major PCBs, and does NOT indicate the direction of signals.

3 Basic Sequence of Operations

3.1 Basic Sequence of Operations at Power-On

Period	Description
WMUP (warm-up)	From when the main power switch is turned on until the surface temperature of the fixing roller reaches 90°C.
SSTBY (scanner standby)	From when shading correction ends until the Start key is turned on or the main power switch is turned off.
WMUPR (warm-up rotation)	From when the surface temperature of the fixing roller reaches 90°C until it reaches 190°C (i.e., the drive system has started up and, in addition, bias adjustment and image stabilization correction control are under way).
PSTBY (printer standby)	From WMUPR ends until the Start key is enabled.

T02-301-01

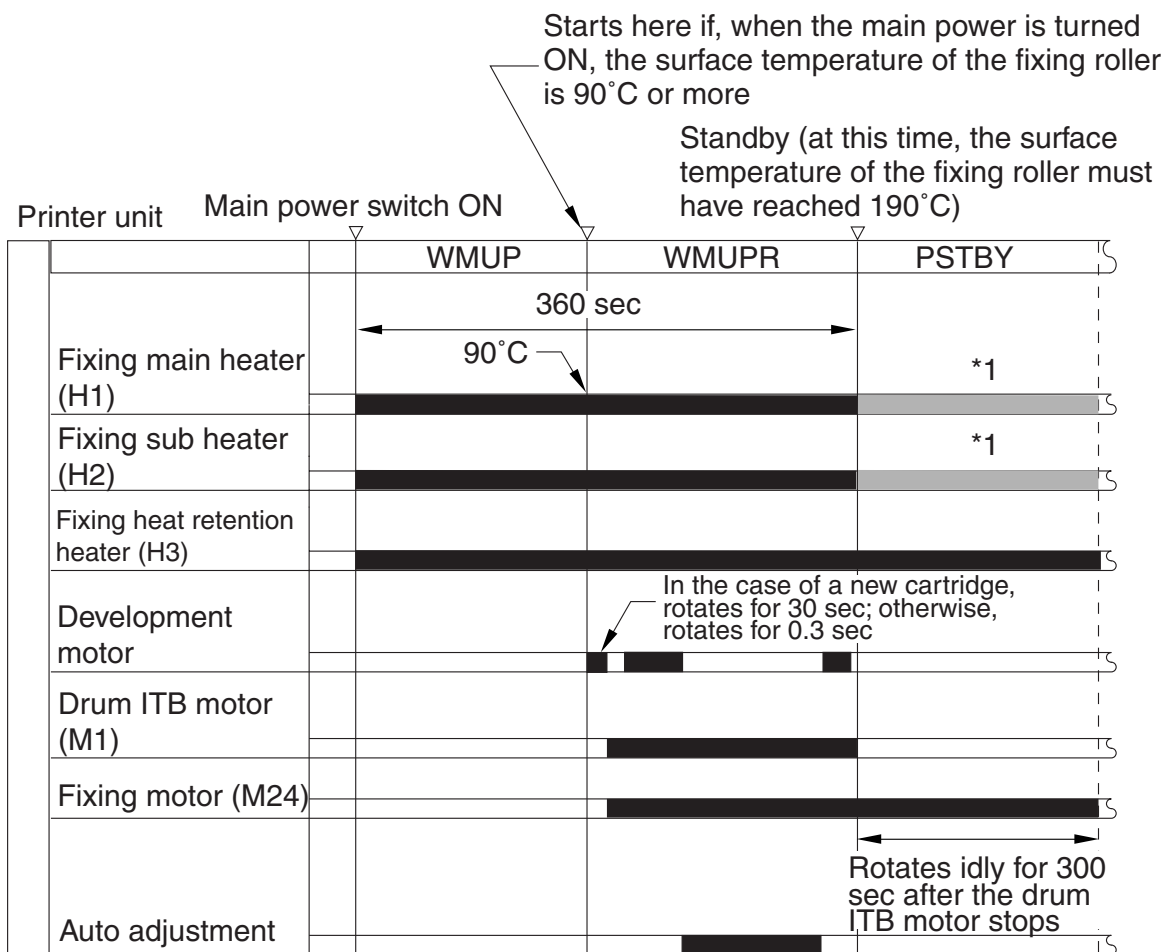
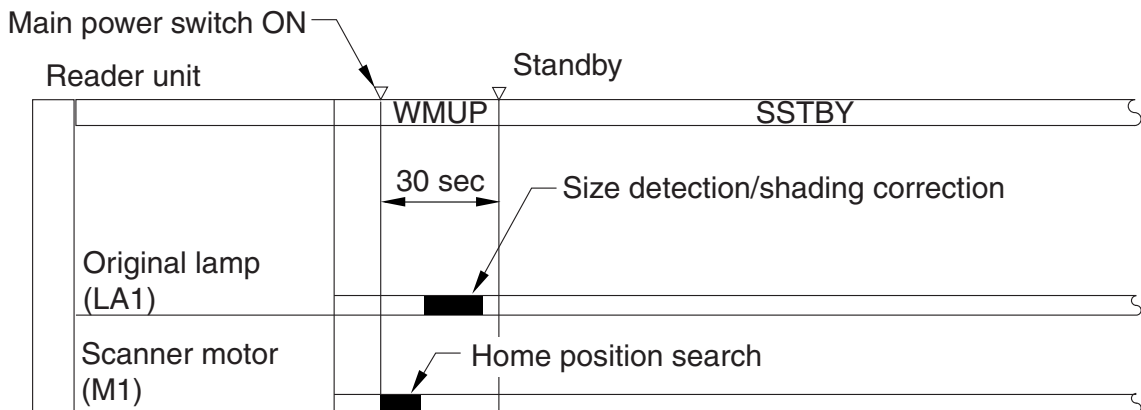

*1: The main heater or the sub heater is used for temperature control according to the difference in the readings between the main thermistor (TH1) and the sub thermistor (TH2). (control at 190°C)

The following control is executed according to the surface temperature of the fixing roller when the main power is turned ON:

- if less than 100°C,
 - [1] discharge current control
 - [2] ATVC control
 - [3] ATR control
 - [4] SALT-Dmax control
 - [5] image position correction
 - [6] SALT-Dhalf control
- if 100°C or higher
 - [1] discharge current control
 - [2] ATVC control
 - [3] image position control

3.2 Basic Sequence of Operations

a. Full-Color

full-color, A4, 2 copies continuous, 100%, cassette 1

Period	Description
SSTBY	From when shading ends until the Start key is turned ON or the main power is turned OFF.
SREADY	While shading correction is under way after a press on the Start key.
SCFW	While an original is being read (scanner forward).
SCRV	While the scanner is returning to the home position after the original is read (scanner in reverse).
PSTBY (print standby)	While the machine is ready to review a print request signal.
PINTR (printer initial rotation)	From when a print request signal is received until the image leading signal is sent.
PRINT	Until all toner is transferred to paper.
LSTR (last rotation)	From when printing ends until all drive stops.

T02-302-01

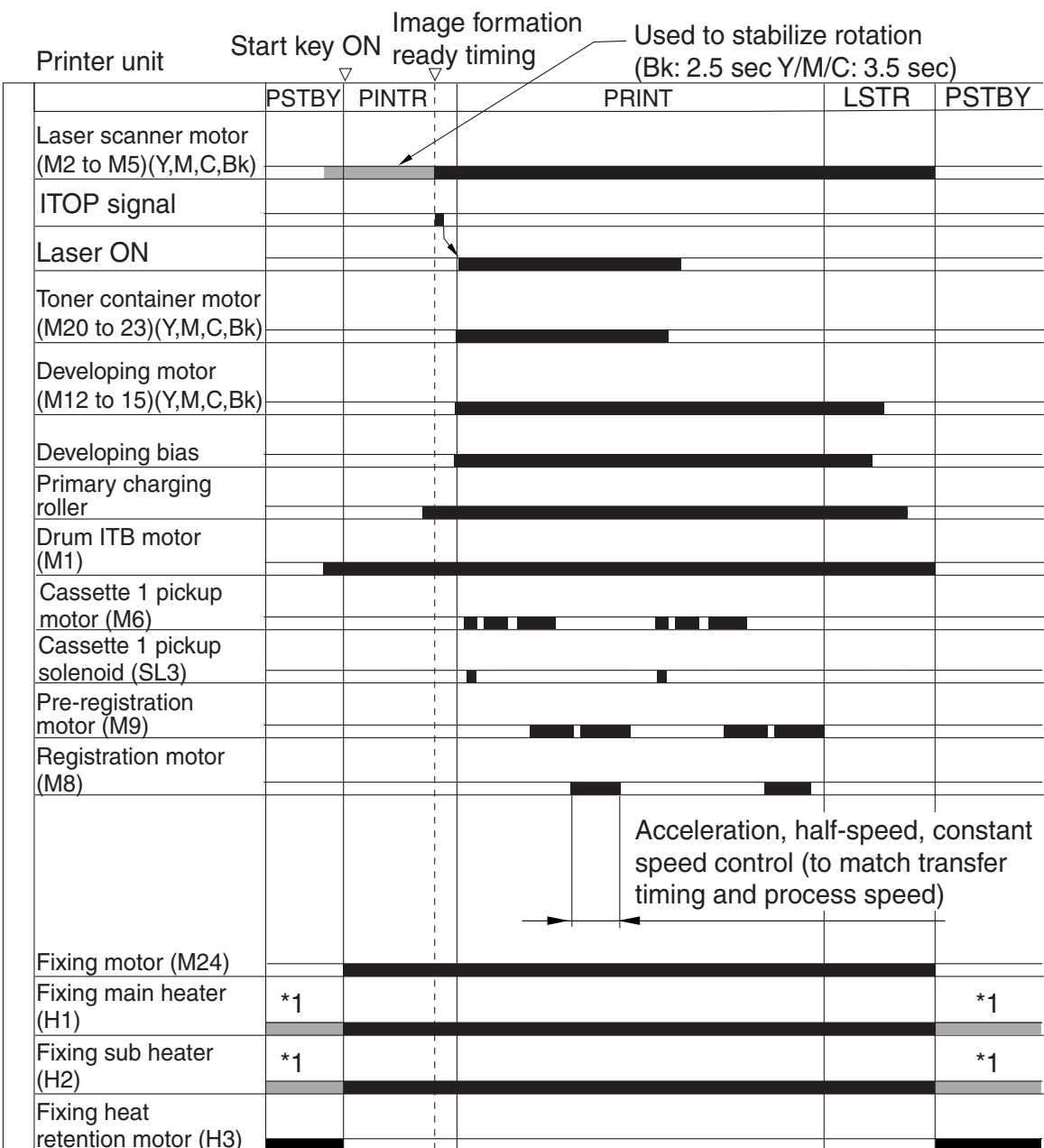
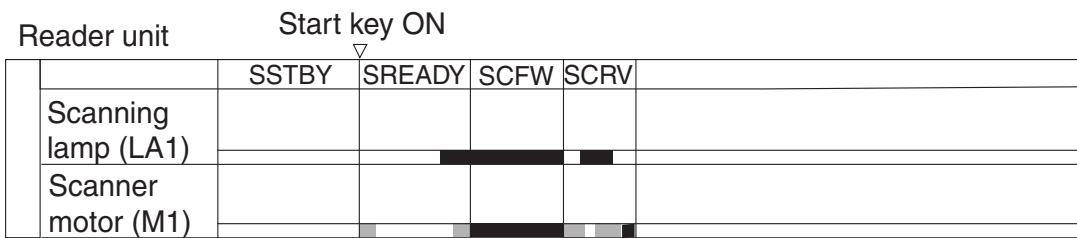

*1: The machine executes temperature control using the main heater or the sub heater according to the difference in the readings of the main thermistor (TH1) and the sub thermistor (TH2). (control at 190°C)

F02-302-01

b. Monochrome

monochrome, A4, 2 copies continuous, 100%, cassette 1

Period	Description
SSTBY	While an original is being read.
SREADY	While shading correction is under way after a press on the Start key.
SCFW	While an original is being read.
SCRV	While the scanner is returning to the home position after an original has been read.
PSTBY (print standby)	While the machine is ready to receive a print request signal.
PSINTR (printer initial rotation)	From when a print request signal is received until when the image leading signal is received.
PRINT	Until all toner is transferred to paper.
LSTR (last rotation)	From when printing ends until all drive stops.

T02-302-02

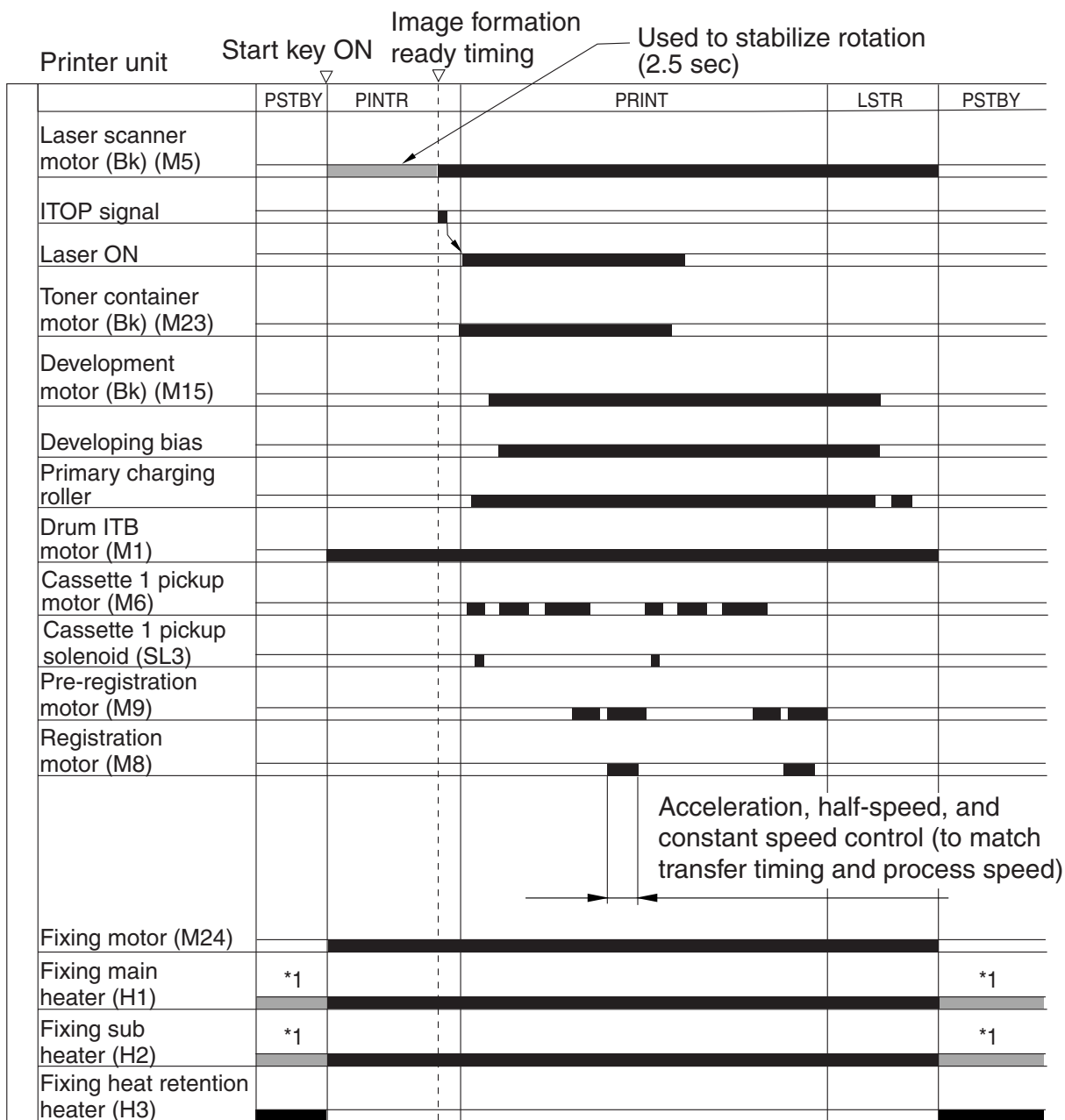
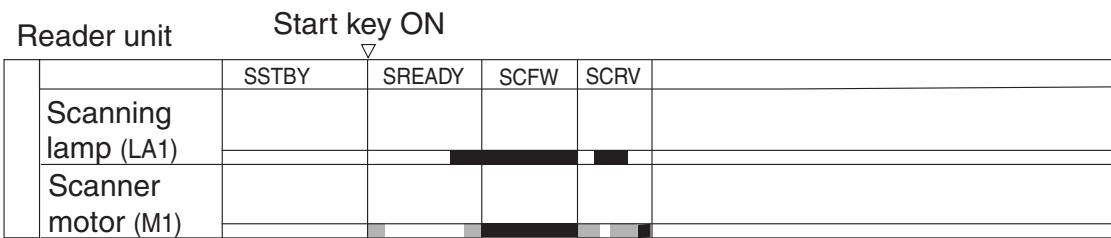

*1: The machine uses the main heater or the sub heater for temperature control according to the difference in the readings of the main thermistor (TH1) and the sub thermistor (TH2). (control at 190°C)

F02-302-02

CHAPTER 3

MAIN CONTROLLER

1 Specifications, Control Mechanisms, and Functions

The major specifications, control mechanisms, and functions of the main controller are as follows:

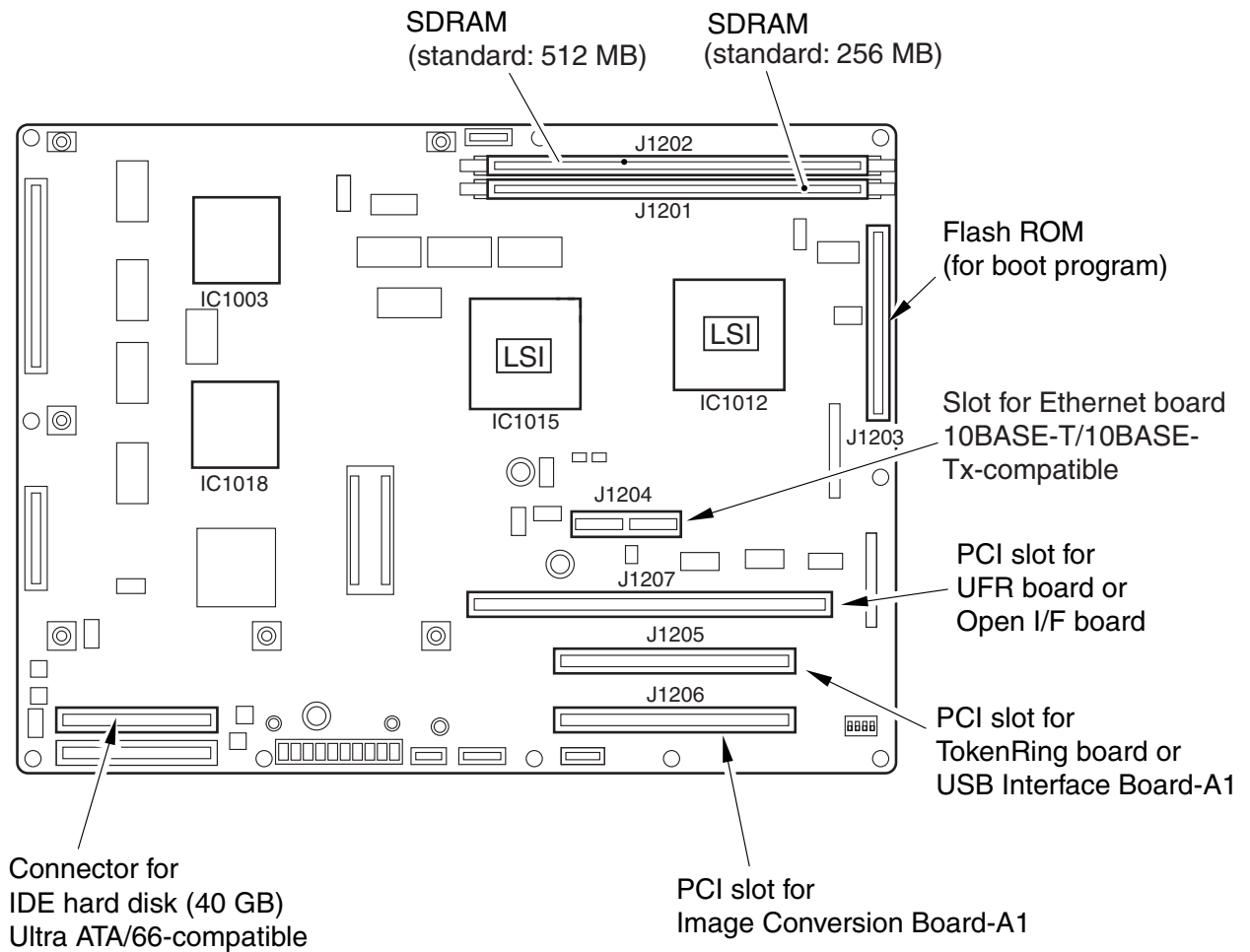

F03-100-01

2 Basic Operations

2.1 Functional Construction

The machine may be broadly divided into the following functional blocks (main controller indicated with shading):

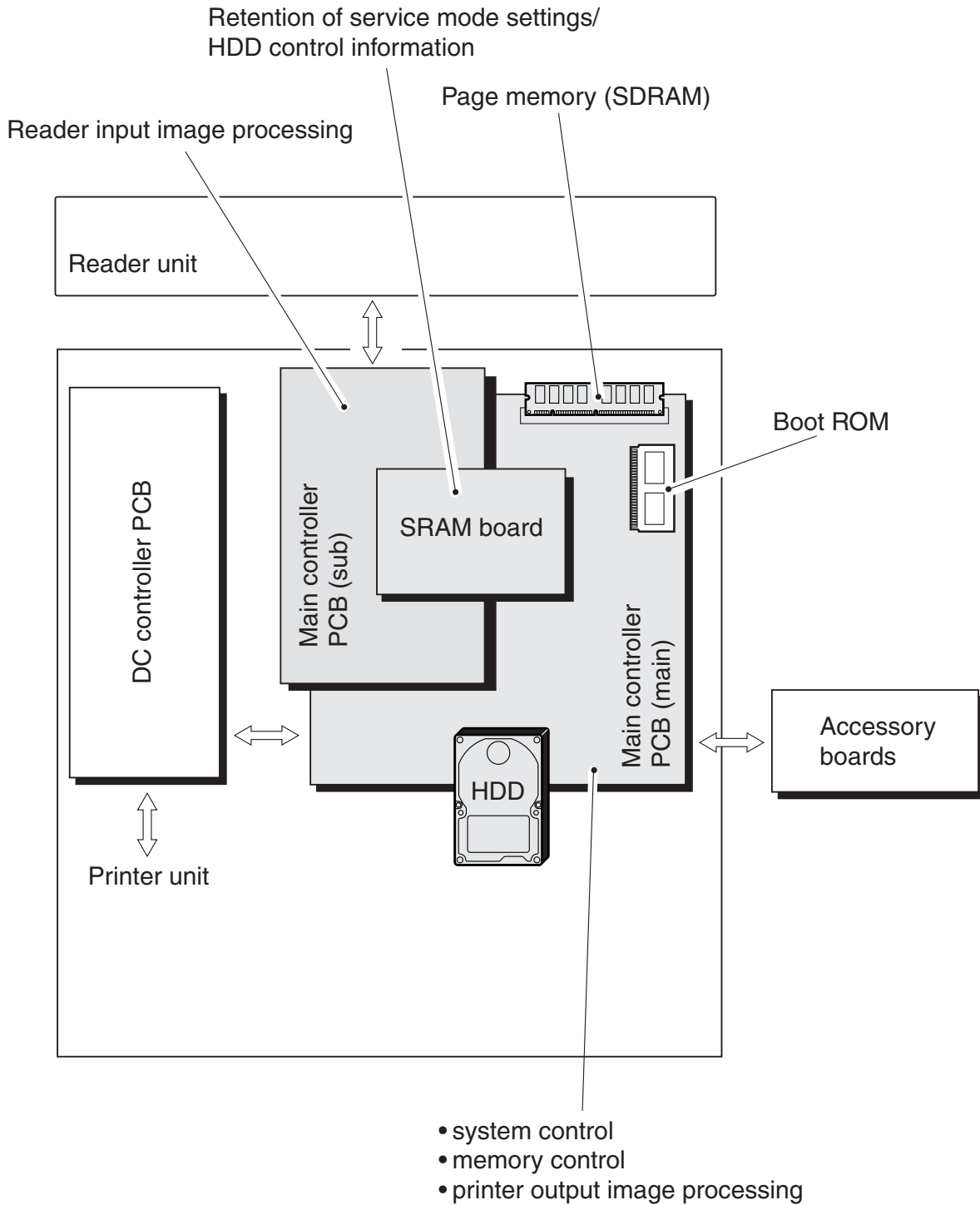

F03-201-01

2.2 Outline of the Electrical Circuitry

2.2.1 Outline

The major mechanisms of the main controller PCB are controlled by the CPU on the main controller PCB.

To save on physical space, the machine's main controller PCB is divided into two: main and sub.

The sub PCB serves to process input images coming from the reader unit, while the main PCB serves to control jobs, output images going to the printer, and memory.

2.2.2 Main Controller PCB

Main Controller PCB (main)

IC No.	Description
IC1012	CPU: system control network controller PCI bus controller serial communications controller ROM/RAM controller
IC1015	image input/output and image processing
IC1003, 1018	image processing control of output image data to printer unit
IC1029	HDD control
SDRAM	temporary storage of image data, temporary storage of image data control information and program data
Boot ROM (Flash ROM)	storage of boot program
HDD	storage of system software storage of image data for Box/FAX functions

T03-202-01

Main Controller PCB (sub)

IC No.	Description
IC10	image processing control of input image data from reader unit
IC15	input/output processing
SRAM board	control information of image data stored on HDD service mode settings data

T03-202-02

Main Controller PCB (main)

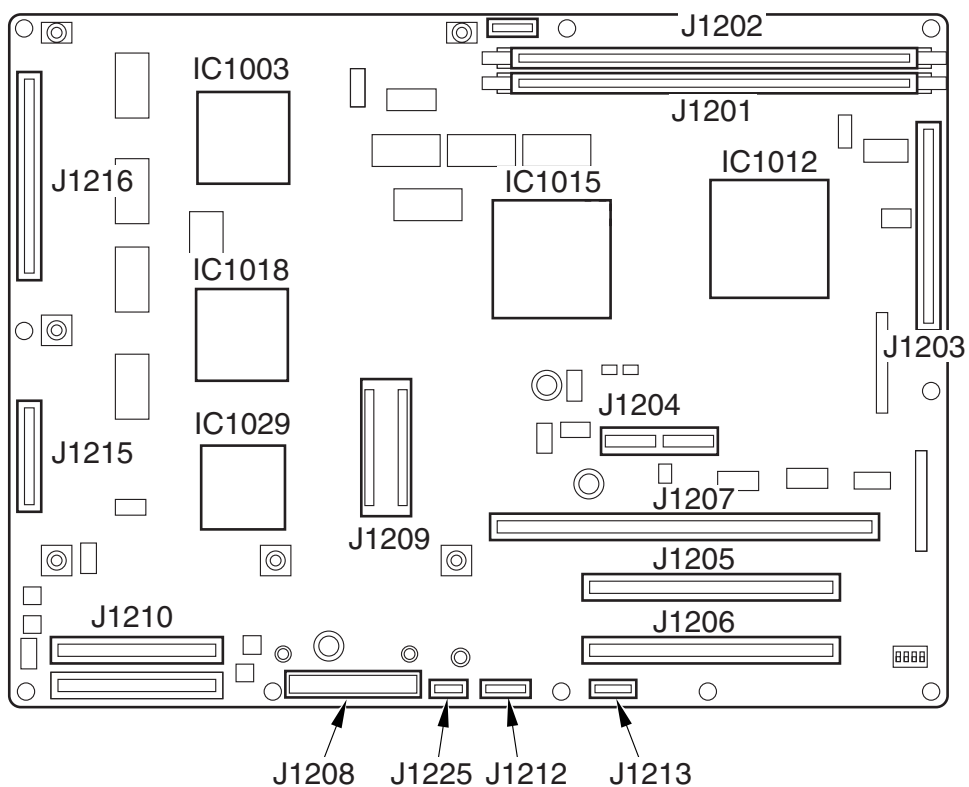

F03-202-01

Main Controller PCB (sub)

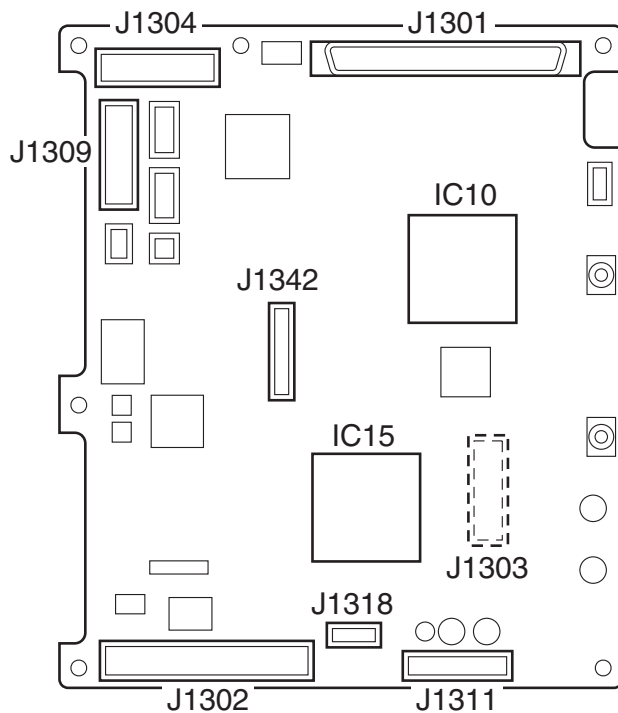

F03-202-02

2.3 Startup Sequence

2.3.1 Outline

The system control software used to control the machine is stored on the HDD. At time of startup, the CPU on the controller PCB follows the boot program to read the system software from the HDD to the SDRAM on the controller PCB.

While the CPU reads the system software from the HDD to the SDRAM, the control panel shows the following screen, and the startup sequence under way is indicated by the progress bar on the screen.

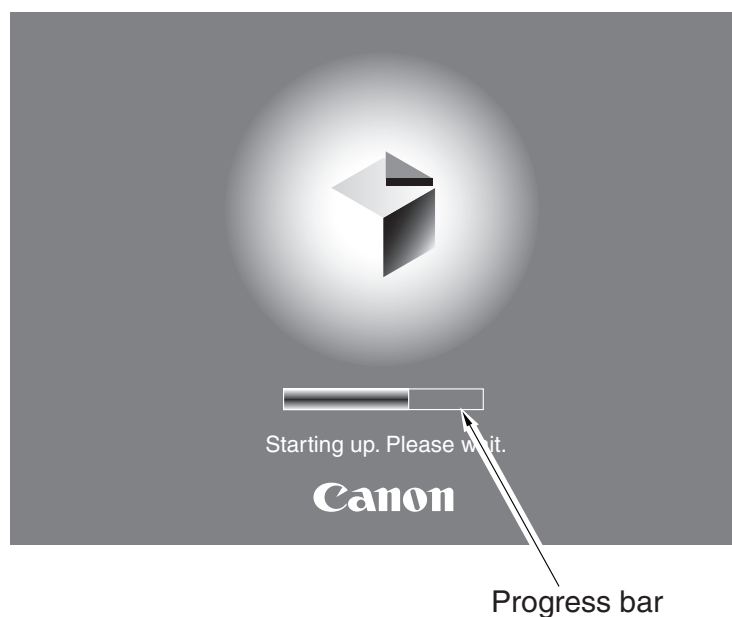

F03-203-01



Never turn off the main power while the progress bar is indicated. The HDD is being accessed during the period, and turning off the power can cause a fault (E602) on the HDD.

2.3.2 Startup Sequence

1. When the main power switch is turned on, the CPU on the main controller PCB first executes the self diagnostic program stored in the boot ROM.
2. The self diagnosis checks the conditions of the HDD and, upon detection of a fault, the machine will indicate an error code on its control panel.
3. When the self diagnosis ends normally, the boot program stored also in the boot ROM will start up.
4. The boot program reads the system software from the HDD for writing to the system area of the SDRAM.
5. When writing ends, the system software starts up in the SDRAM, starting to initialize the machine's various parts.
6. When these parts have all been initialized, the control panel indicates the operation screen and the LED on the Start key changes from red to green to indicate that the machine is ready to accept a job.
7. The machine's system software consists of multiple modules, and the machine brings in those modules that are needed for specific processing into the system area of the SDRAM for use.

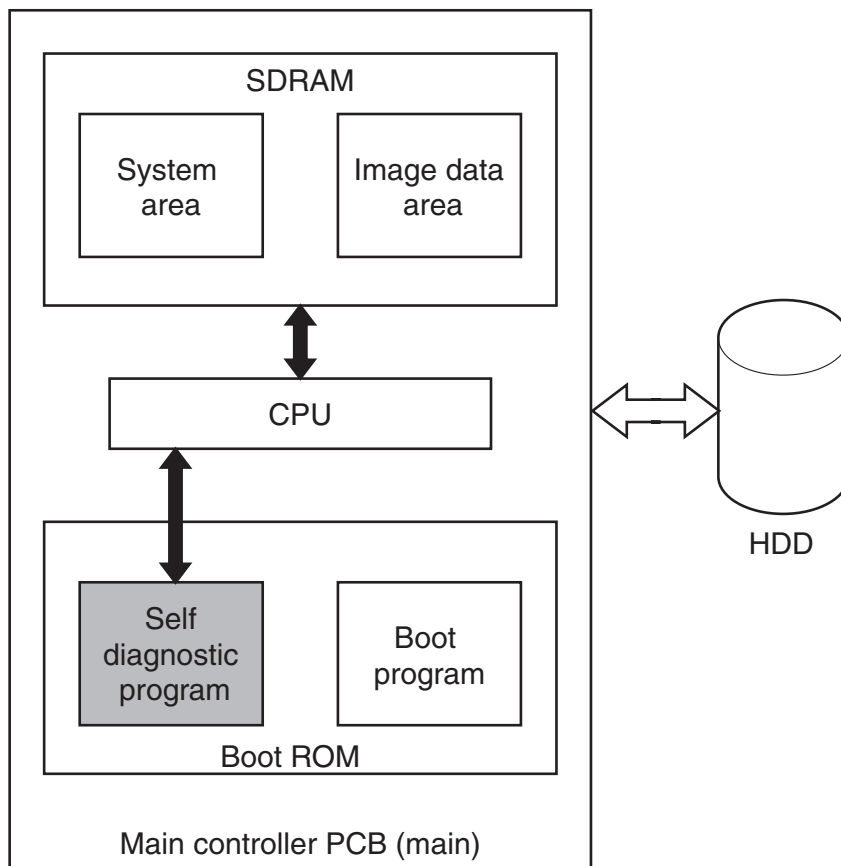

↔ : access to a program for execution.

F03-203-02

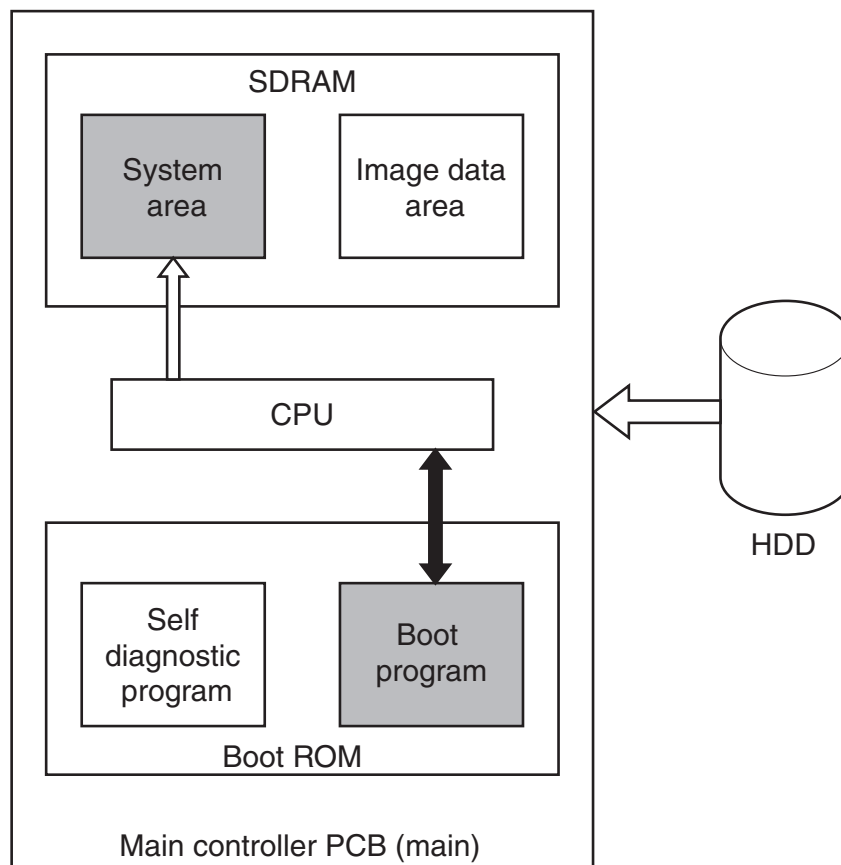

↔ : access to a program for execution.

⇐ : flow of a system program.

F03-203-03

2.3.3 Construction of the System Software

The machine's system software may broadly be divided into a system model (system for control) and a language module (for LCD indications). Whenever you upgrade the system software, you must upgrade the system module, language module, and RUI at the same time.

3 Image Processing

3.1 Flow of Images

The following diagram shows the flow of images in relation to the machine's various functions:

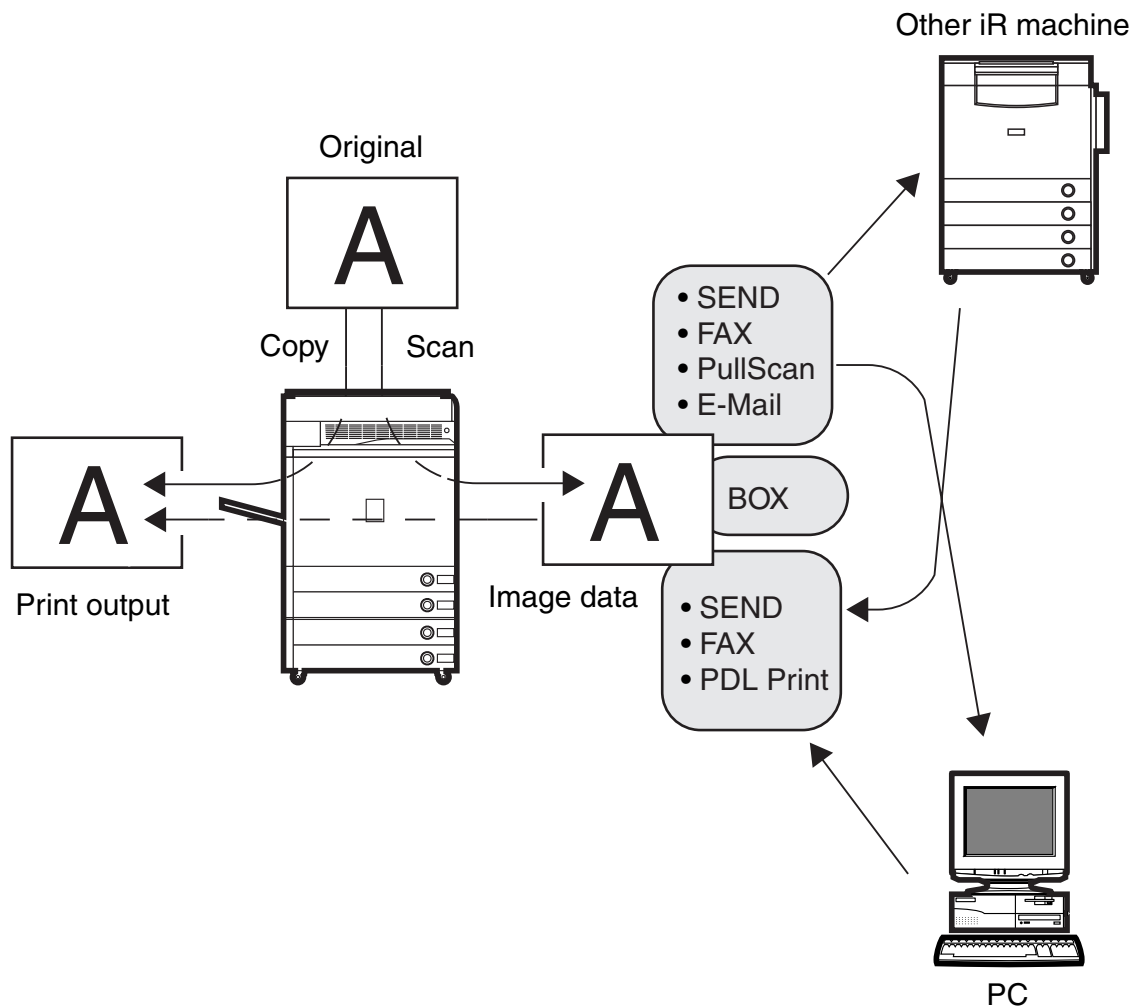

F03-301-01

3.2 Construction of the Image Processing Module

The machine's major image processing is undertaken by the main controller; the construction of the modules involved in image processing is as follows:

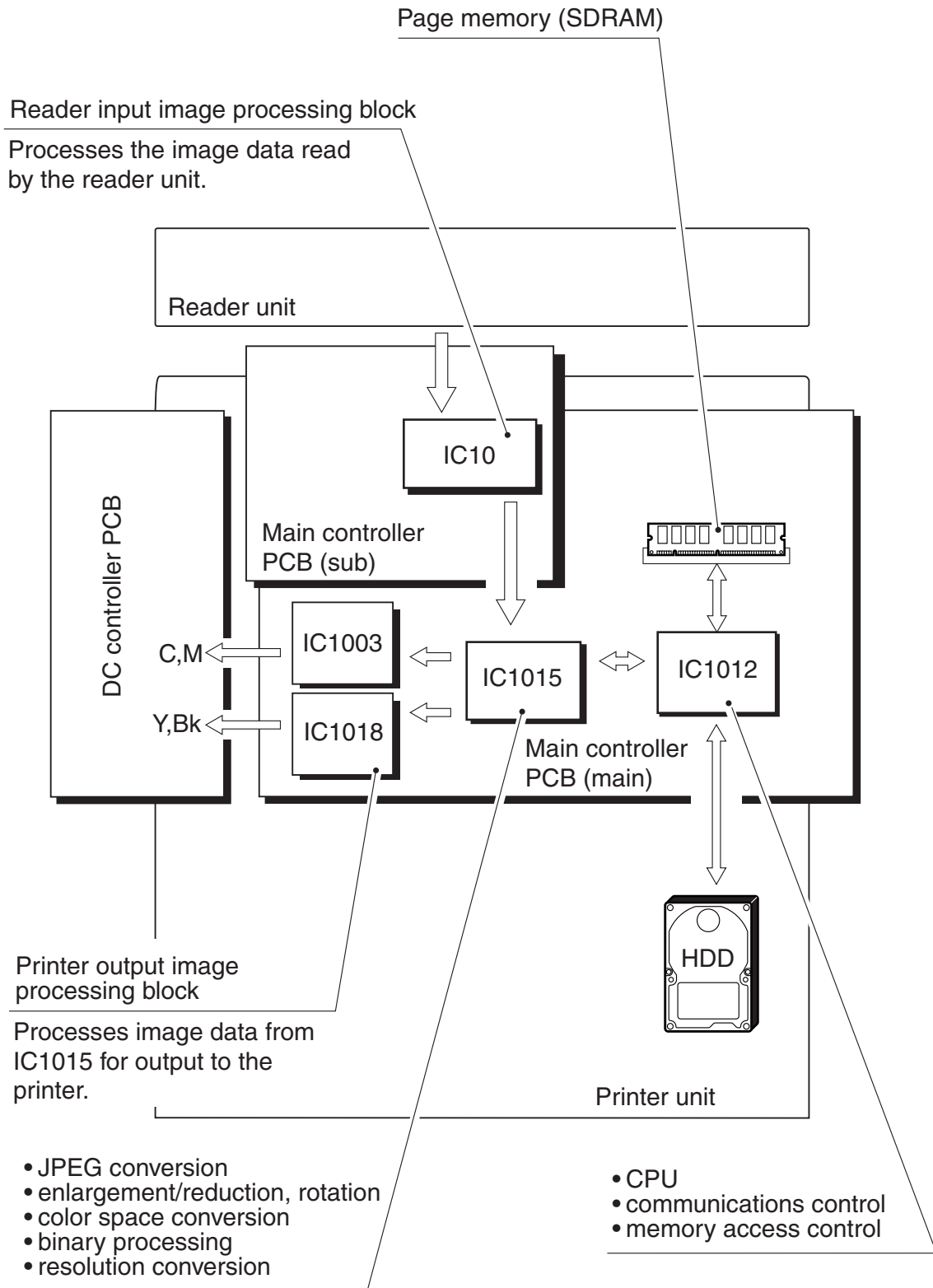

F03-302-01

3.3 Reader Input Image Processing

The image data read by the reader unit (RGB data) is processed by the main controller PCB (sub).

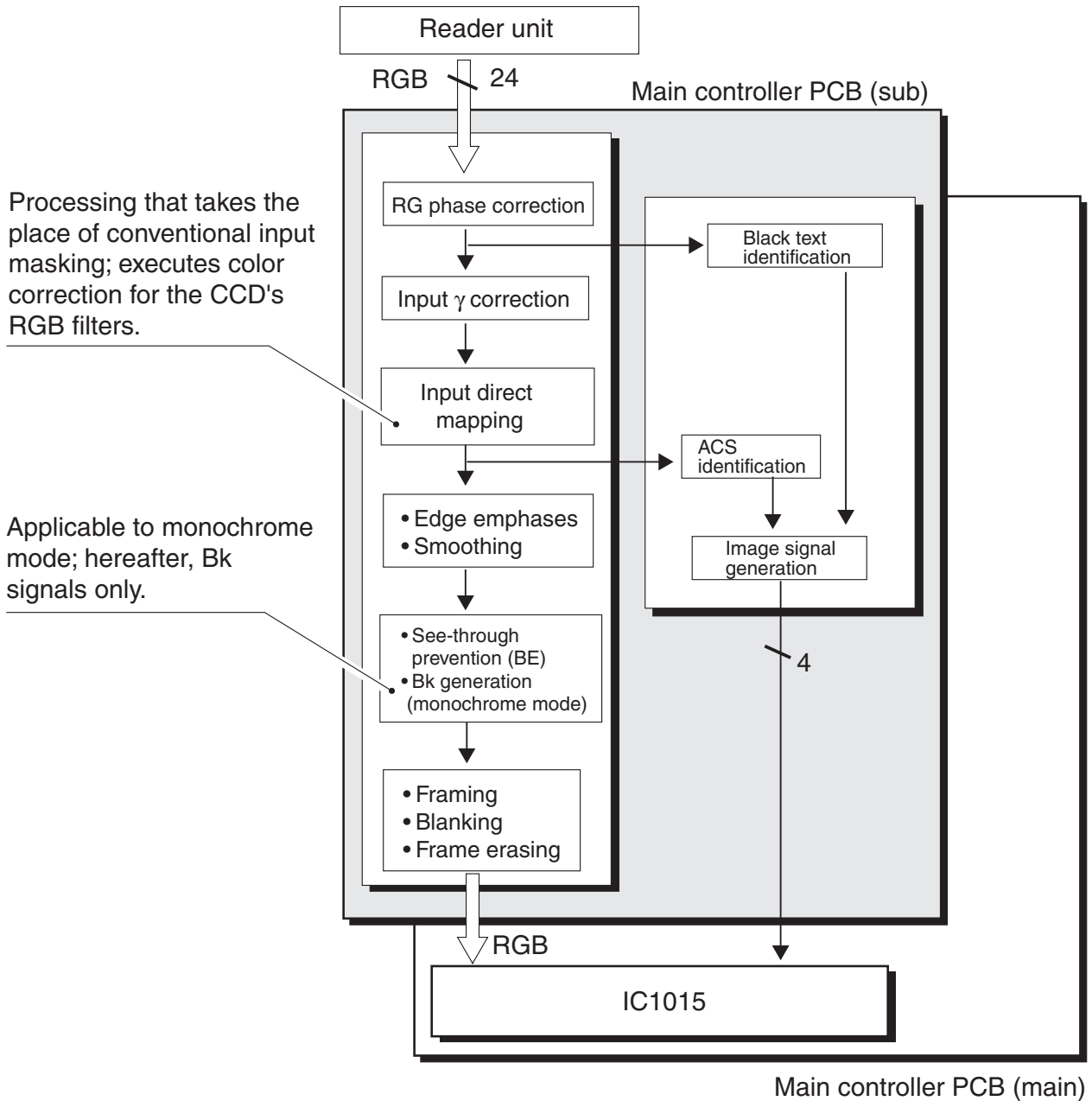

F03-303-01

3.4 Compression/Decompression and Edit Processing Block

The machine uses IC1015 to undertake compression/decompression and edit processing.

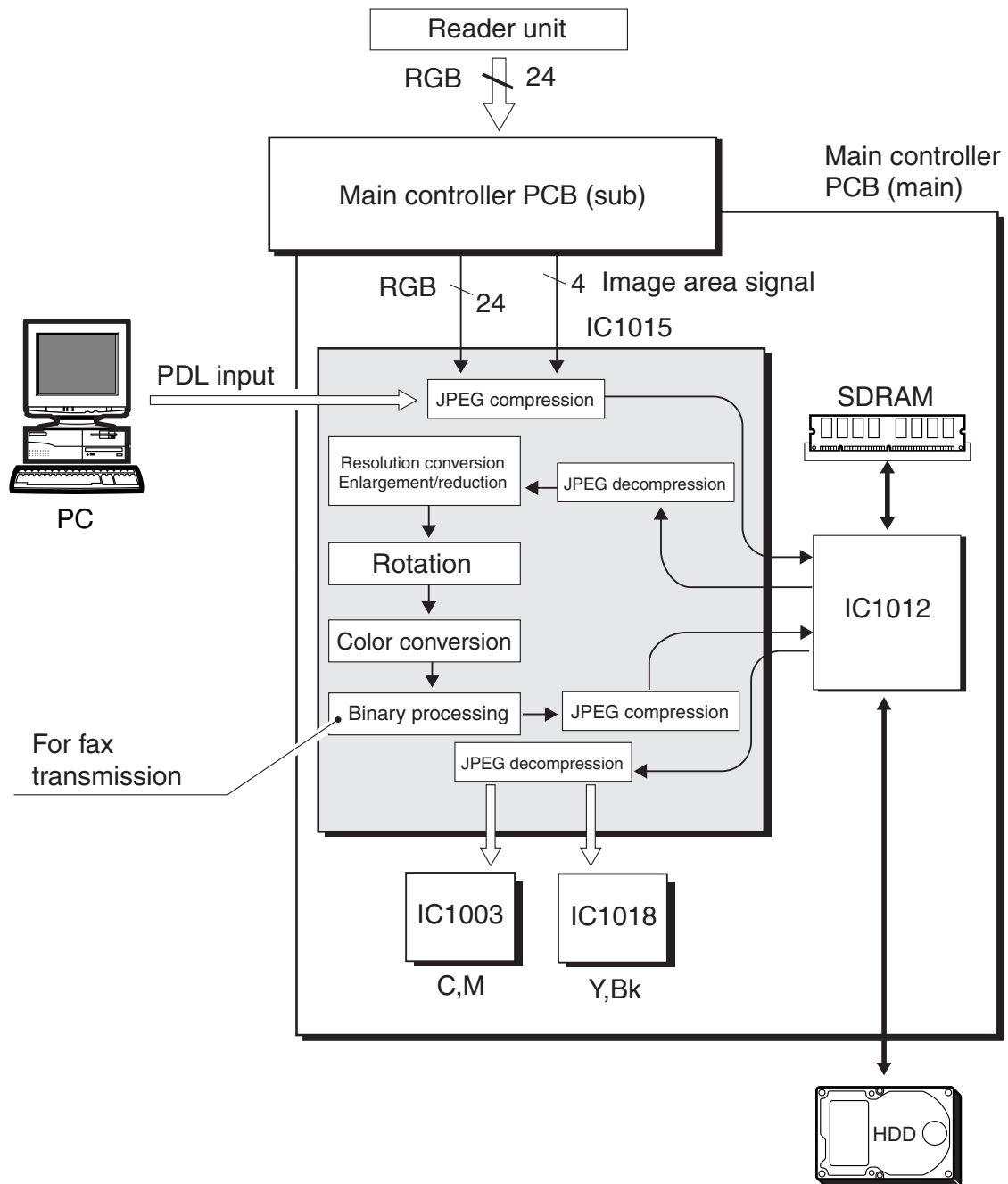

F03-304-01

3.5 Printer Output Image Processing

In this block, the machine processes image data coming from IC1015 for output to the printer.

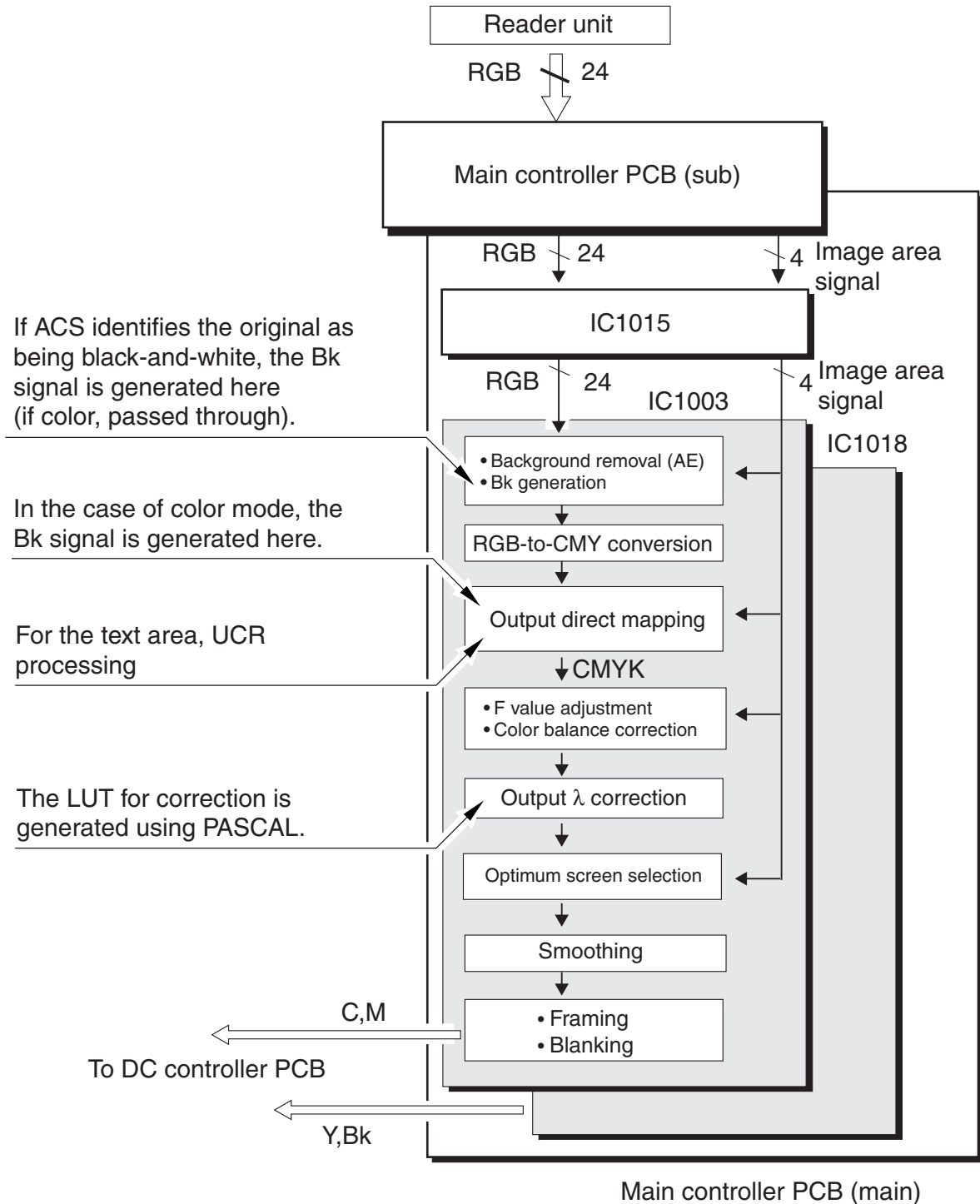

F03-305-01

3.6 Flow of Image Data by Function

3.6.1 Flow of Image Data for Copier Functions

The following diagram shows the flow of image data when copier functions are used:

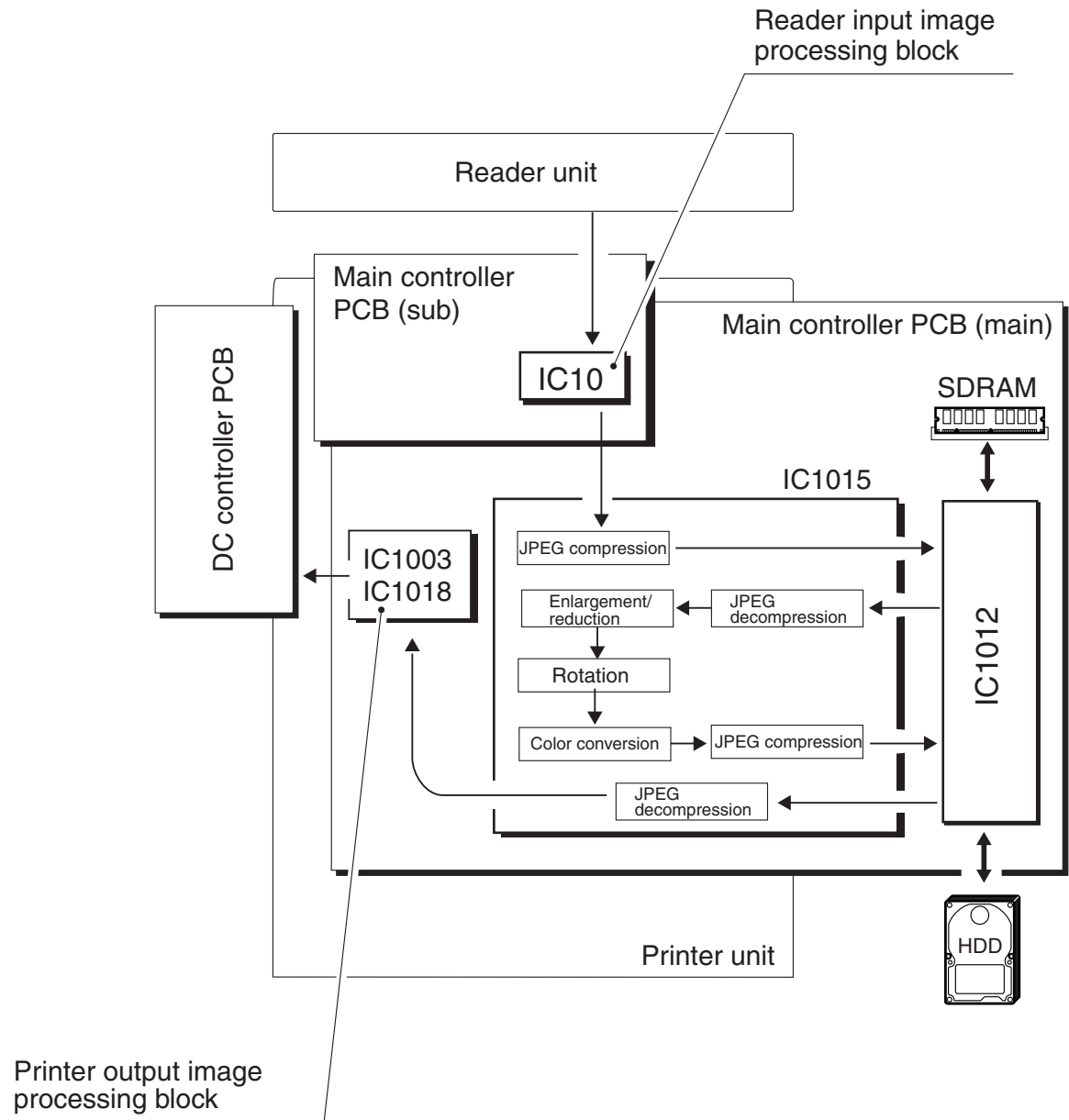

F03-306-01

3.6.2 Flow of Image Data for Box Functions

The following shows the flow of image data when Box functions are used:

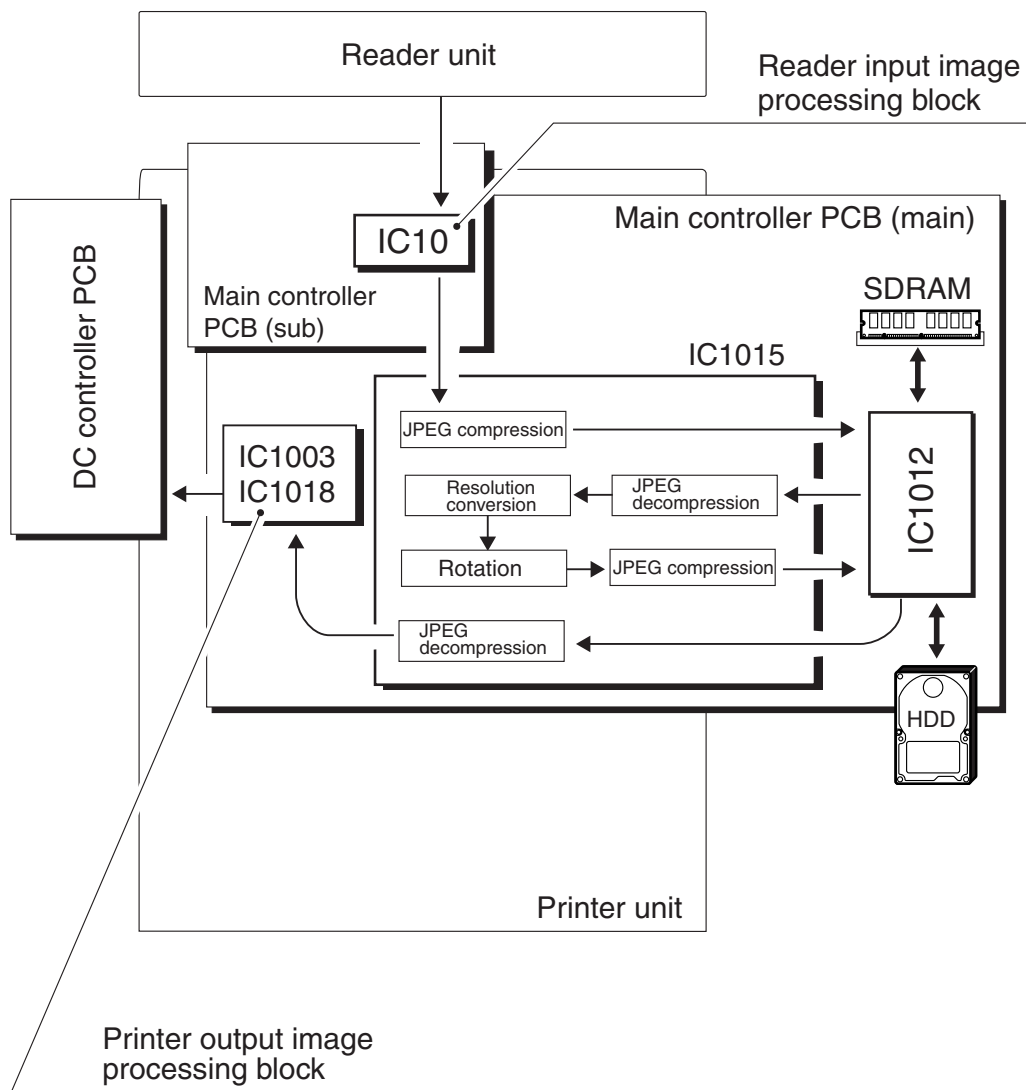

F03-306-02

3.6.3 Flow of Image data for SEND Function

The following shows the flow of image data for SEND functions:

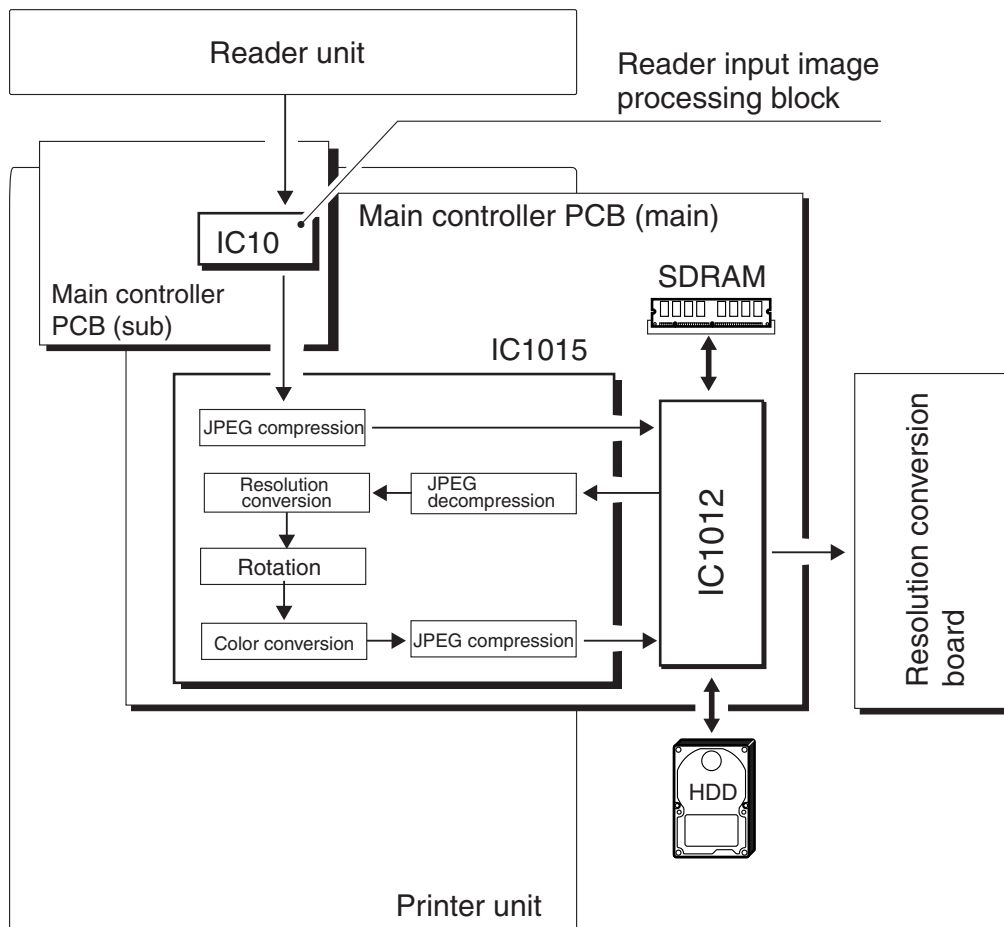

F03-306-03

3.6.4 Flow of Image Data for Fax Transmission Functions

The following is the flow of image data for fax transmission functions:

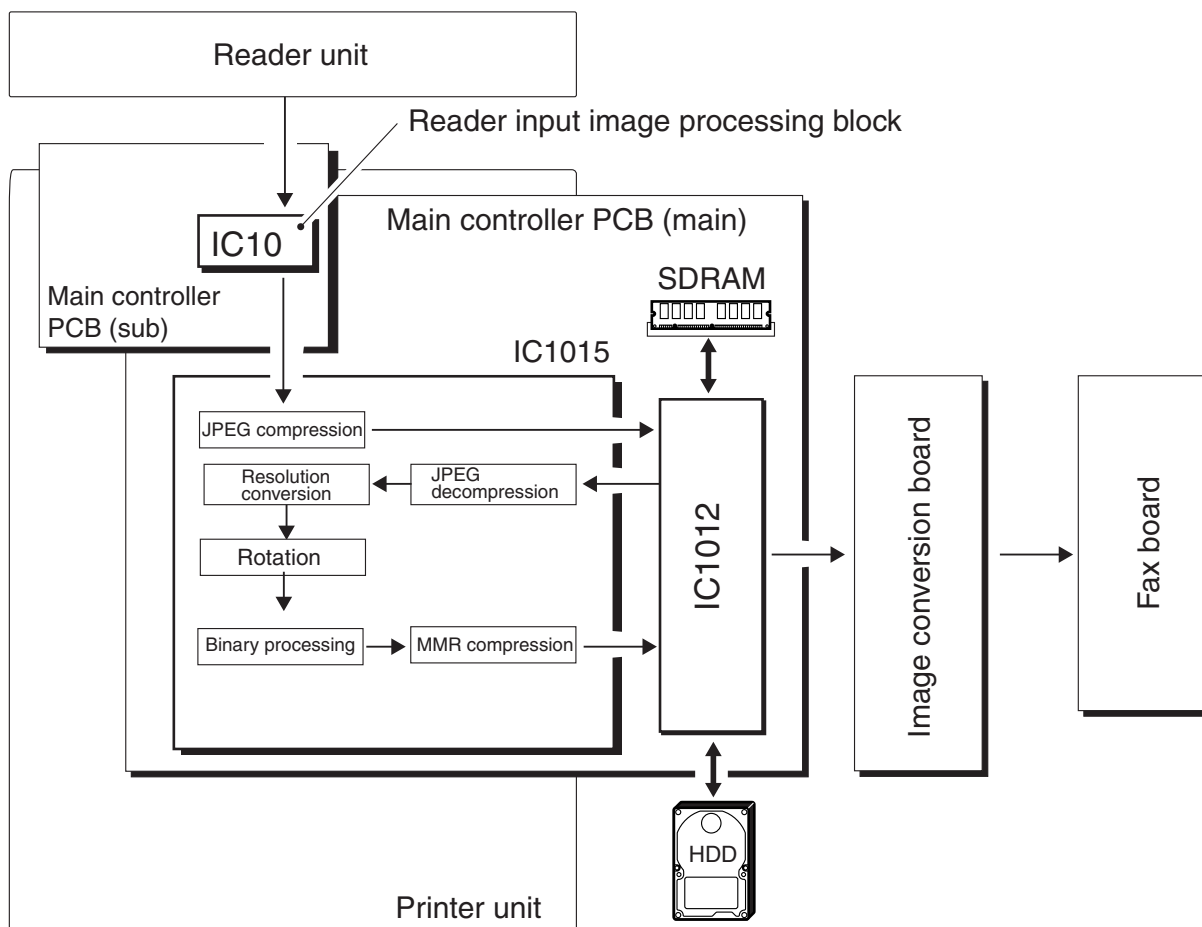

F03-306-04

3.6.5 Flow of Image Data for Fax Reception Functions

The following is the flow of image data for fax reception functions:

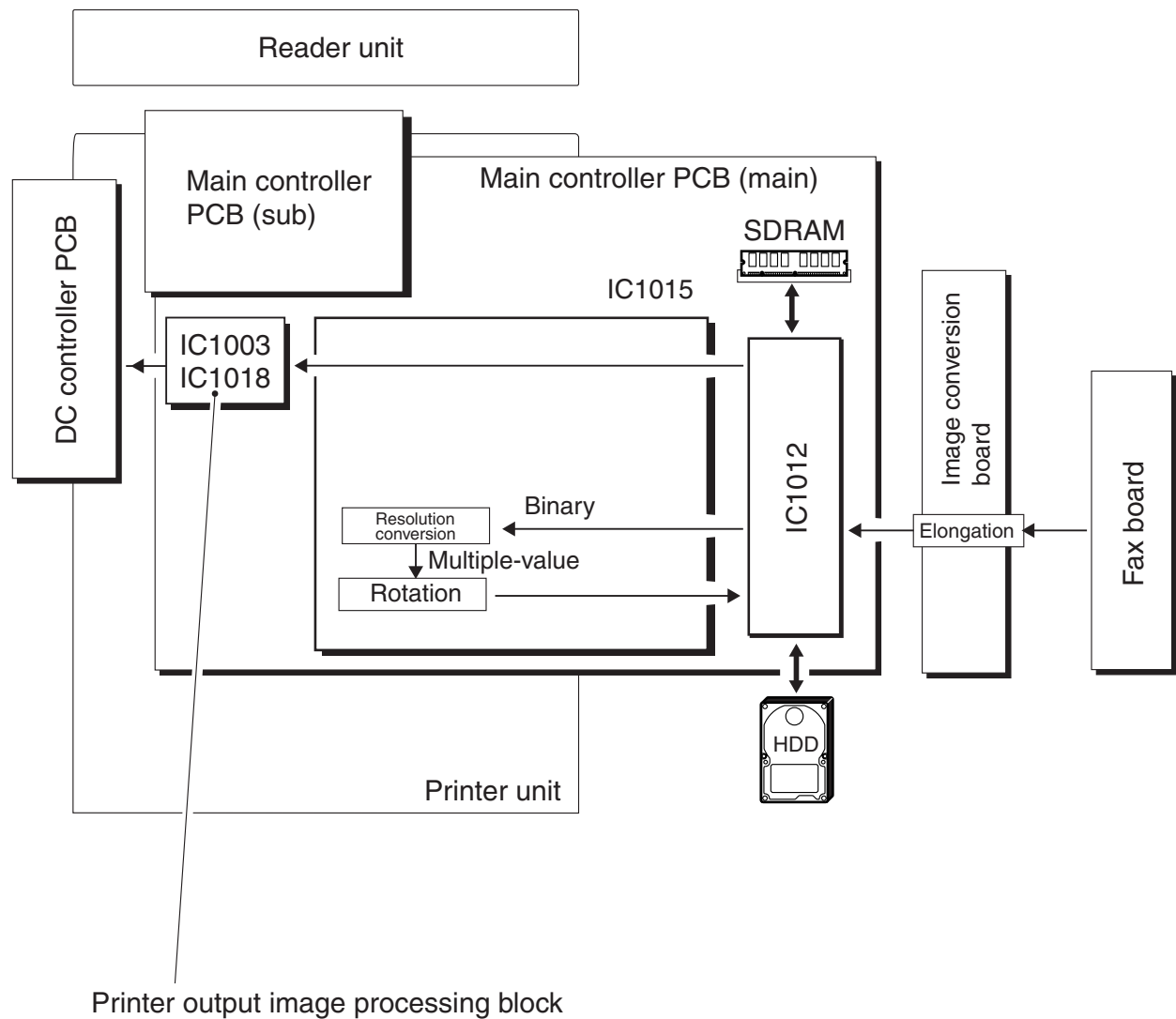

F03-306-05

3.6.6 Flow of Image Data for PDL Functions

The following is the flow of image data for PDL functions:

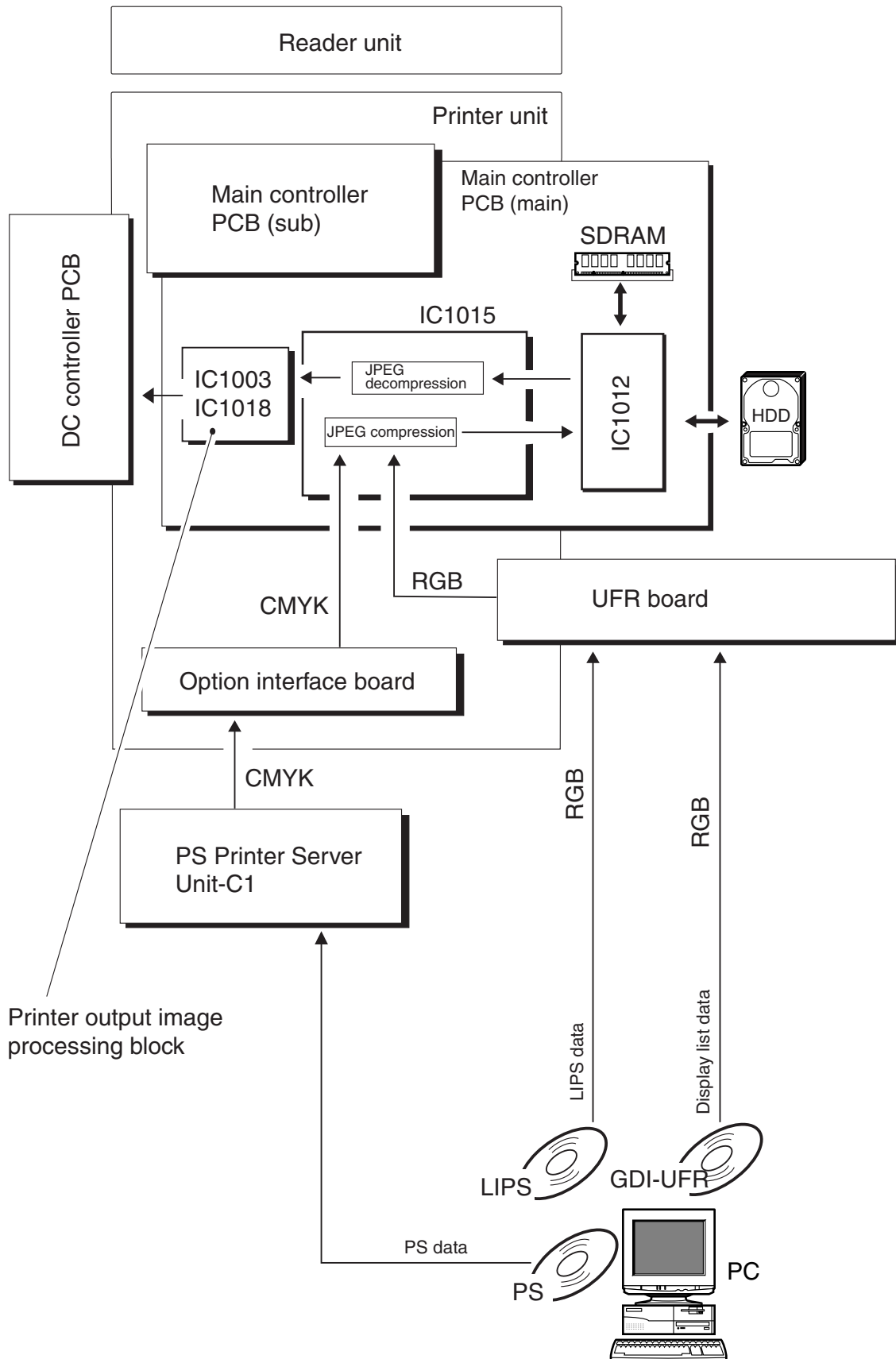

F03-306-06

4 Disassembly and Assembly

4.1 Removing the Controller Fan

- 1) Remove the upper rear cover.
- 2) Remove the main controller box cover.
(See 5.21 'Removing the Controller PCB' in Chapter 7 of the Printer Volume.)
- 3) Disconnect the connector [1], and remove the 4 screws [2]; then, detach the controller fan [3].

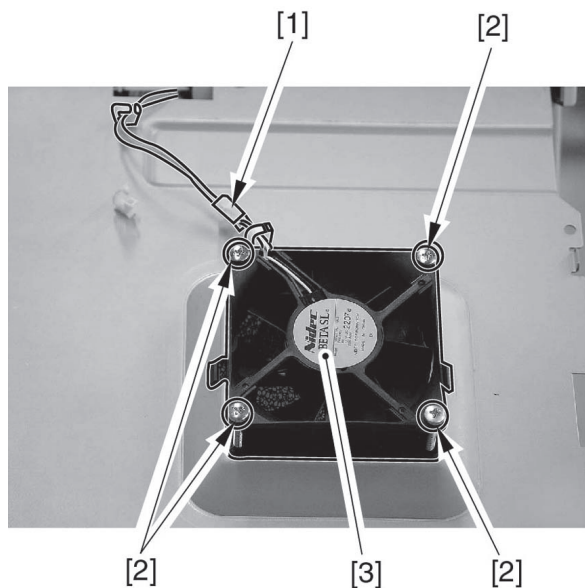

F03-401-01

4.2 Removing the Main Controller PCB (main)

- 1) Remove the upper rear cover.
- 2) Remove the left upper rear cover.
- 3) Remove the cover of the DC controller PCB. (See 5.21 ‘Removing the DC Controller PCB’ in Chapter 7 of the Printer Volume.)
- 4) Remove the cover of the main controller box. (See 5.21 ‘Removing the DC Controller PCB’ in Chapter 7 of the Printer Volume.)
- 5) Remove the HDD. (See 4.9 ‘Removing the HDD.’)
- 6) Remove the HDD mounting plate (2 locations). (See 4.3 ‘Removing the Main Controller PCB (sub).’)
- 7) Remove the Ethernet board. (See 4.6 ‘Removing the Ethernet Board.’)
- 8) Remove the UFR board. (See 4.5 ‘Removing the UFR Board.’)
- 9) Remove the main controller PCB (sub).
- 10) Remove the 2 flat cables [1] used for connection to the DC controller PCB.

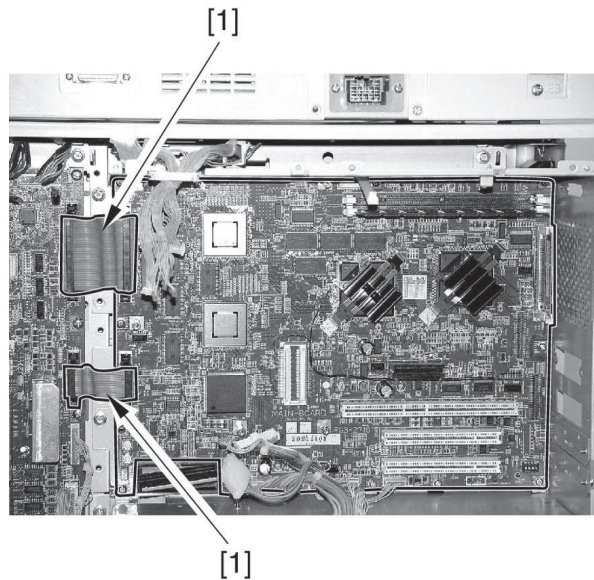

F03-402-01

- 11) Disconnect the connectors of the PCB; then, remove the 10 screws [1], and detach the main controller PCB (main) [2].

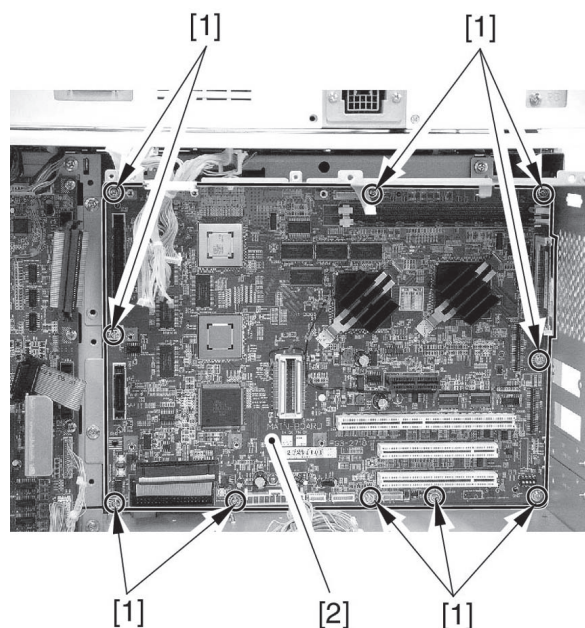

F03-402-02

4.3 When Replacing the Main Controller PCB (main)

Be sure to use the image memory (SDRAM) [1] PCB and the boot ROM [2] from the old PCB on the new main controller PCB (main).

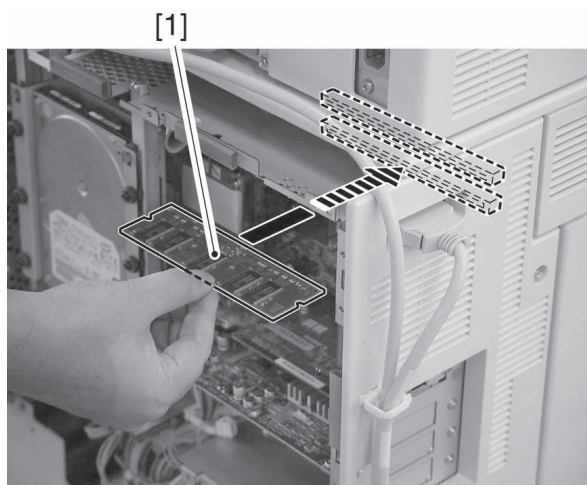

F03-403-01

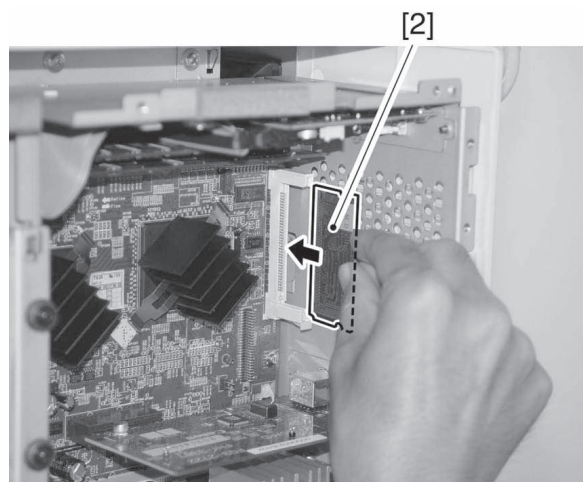

F03-403-02

4.4 Removing the Main Controller PCB (sub)

- 1) Remove the upper rear cover.
- 2) Remove the left upper rear cover.
- 3) Remove the cover of the main controller box. (See 5.21 ‘Removing the DC Controller PCB’ in Chapter 7 of the Printer Volume.)
- 4) Remove the HDD. (See 4.9 ‘Removing the HDD.’)
- 5) Remove the 2 screws [1], and detach the 2 hard disk mounting plates [2].

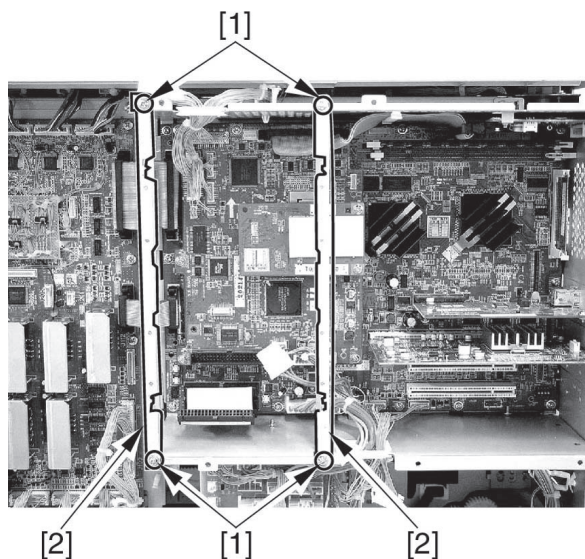

F03-404-01

- 6) Remove the SRAM PCB. (See 4.6 ‘Removing the SRAM PCB.’)
- 7) Disconnect all connectors from the PCB, and remove the flat cable [1].

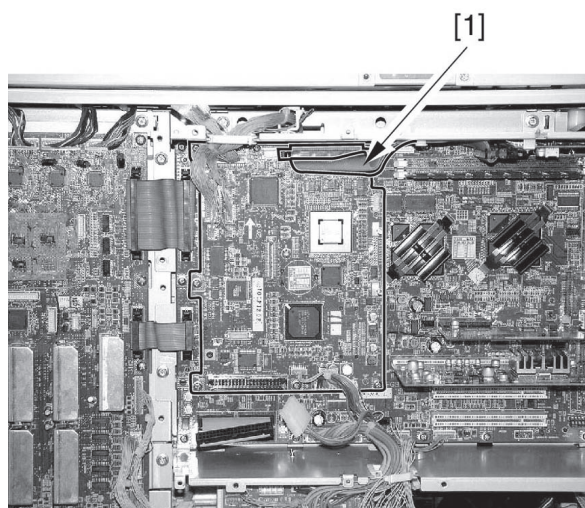

F03-404-02

- 8) Remove the 7 screws [1], and remove the main controller PCB (sub) [2].

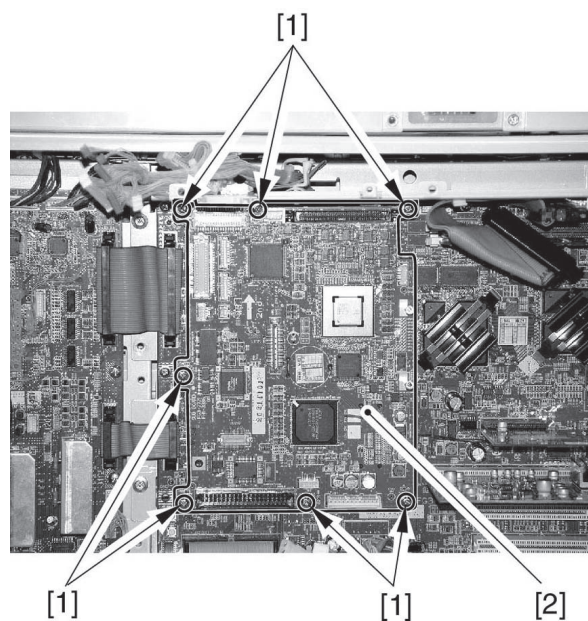

F03-404-03

4.5 When Replacing the Main Controller PCB (sub)

Be sure to use the SRAM PCB [1] from the old PCB on the new main controller PCB (sub) [2].

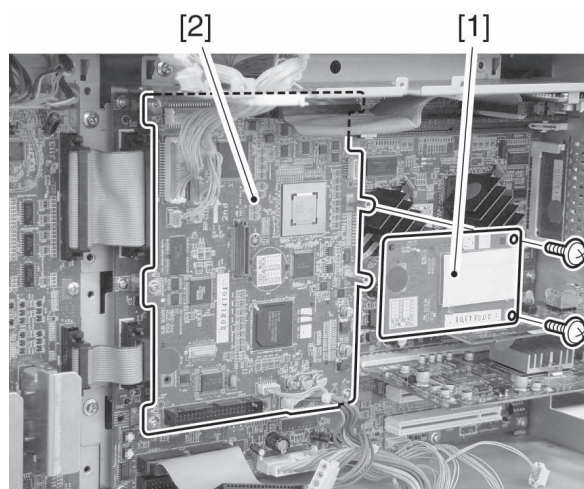

F03-405-01

4.6 Removing the SRAM PCB

- 1) Remove the upper rear cover.
- 2) Remove the cover of the main controller box. (See 5.21 ‘Removing the DC Controller PCB’ in Chapter 7 of the Printer Volume.)
- 3) Remove the HDD. (See 4.9 ‘Removing the HDD.’)
- 4) Remove the 2 screws [1], and detach the SRAM PCB [2].

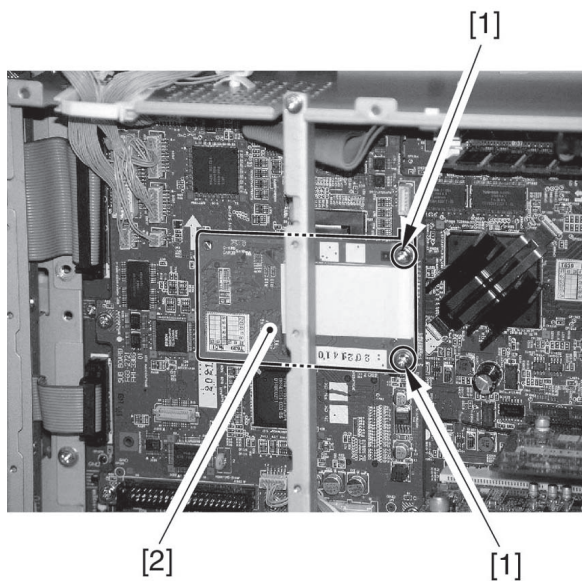

F03-406-01

4.7 Points to Note When Replacing the SRAM PCB



When the SRAM PCB is replaced, all data in its memory will be lost (file-related, user mode-related, service mode-related, history-related files).

There will be no error operation, and initialization will take place automatically.

If you pull out the SRAM PCB from machine B and mount it to machine A, the PCB will be initialized and be rendered useless for machine A or B.

Take full care.

- 1) When you turn on the power after replacing the SRAM PCB, the machine will execute automatic initialization and will indicate a message on its panel to the effect that you are to turn off and then on the power switch found on its right side. Follow the message and turn off and then on the machine.
- 2) Using service mode, initialize the RAM.
COPIER>FUNCTION>CLEAR>MN-CON



Before starting the work, be sure to inform the user that all image data stored in the Box will be lost and obtain his/her consent.

4.8 Removing the UFR Board

- 1) Remove the upper rear cover.
- 2) Remove the left upper cover.
- 3) Remove the cover of the main controller box. (See 5.21 ‘Removing the DC Controller PCB’ in Chapter 7 of the Printer Volume.)
- 4) Remove the 2 screws [1], and detach the UFR board [2] together with its mounting plate.

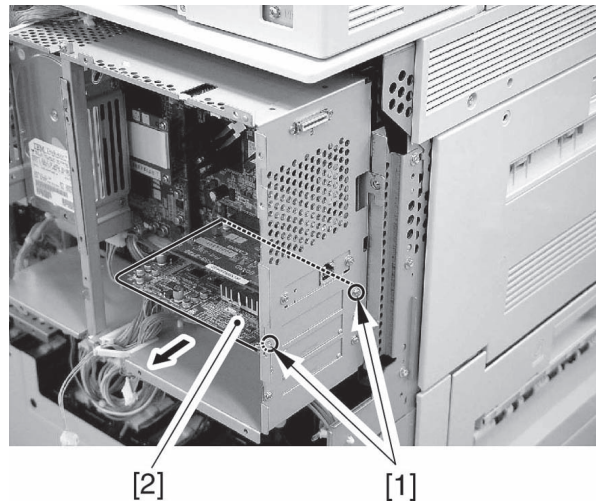

F03-408-01

- 5) Remove the 2 screws [1], and detach the UFR board [3] from its mounting plate [2].

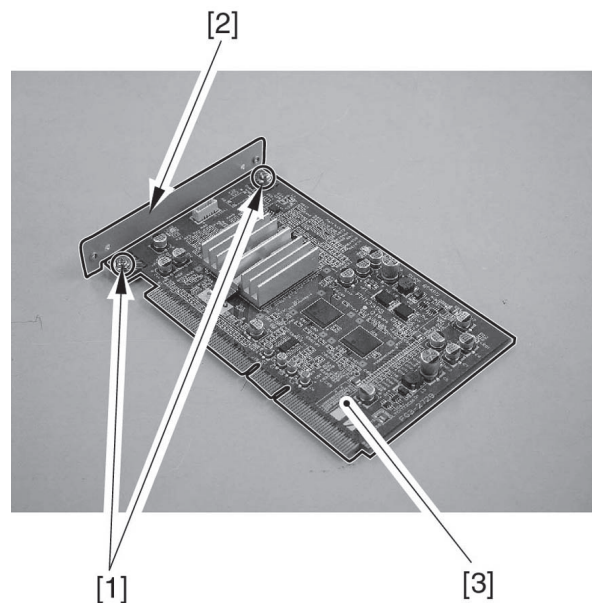

F03-408-02

4.9 Removing the Ethernet Board

- 1) Remove the upper rear cover.
- 2) Remove the rear upper rear cover.
- 3) Remove the cover of the main controller box. (See 5.21 ‘Removing the DC Controller PCB’ in Chapter 7 of the Printer Volume.)
- 4) Remove the 2 screws [1], and detach the Ethernet board [2] together with its mounting plate.

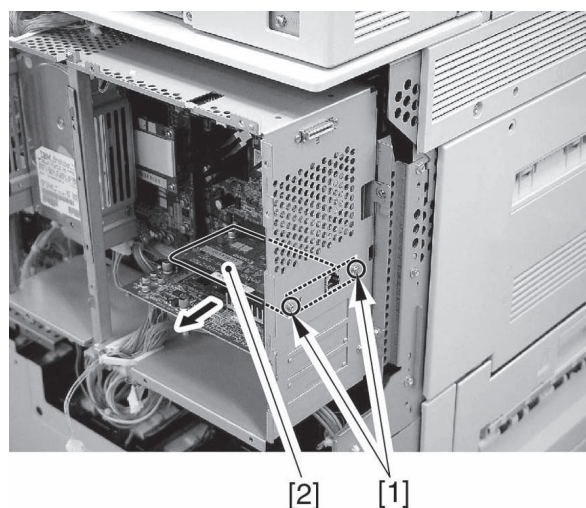

F03-409-01

- 5) Removing the 2 screws [1], and detach the Ethernet board [3] from the mounting plate [2].

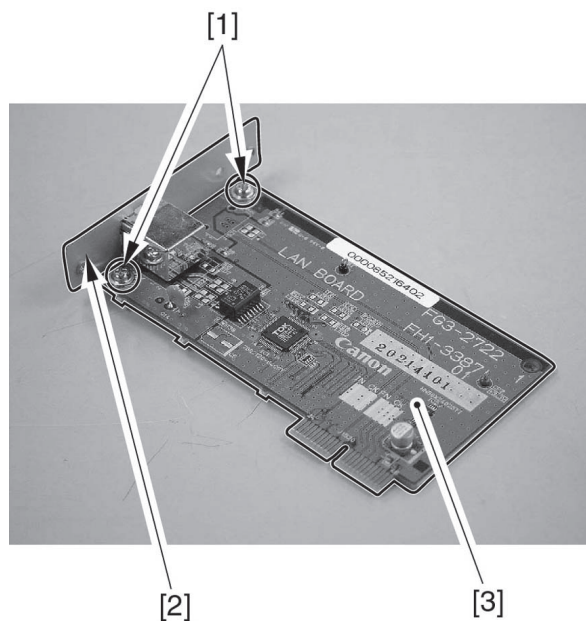

F03-409-02

4.10 Removing the Differential PCB

- 1) Remove the rear upper cover.
- 2) Remove the left upper rear cover.
- 3) Remove the cover of the main controller box. (See 5.21 'Removing the DC Controller PCB' in Chapter 7 of the Printer Volume.)
- 4) Remove the flat cable [1].

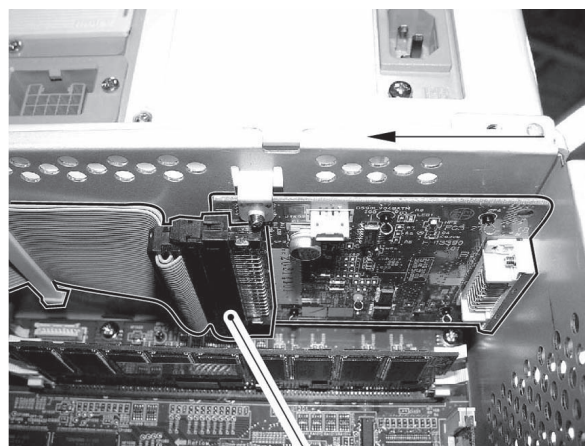

[1]

F03-410-01

- 5) Remove the 3 screws [1], and detach the differential PCB [2].

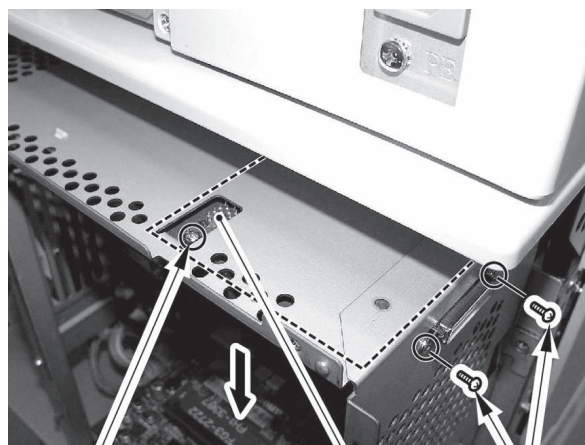

[1]

[2]

[1]

F03-410-02

4.11 Removing the Power Distribution PCB

- 1) Remove the upper rear cover.
- 2) Disconnect the connectors from the PCB, and remove the 4 screws [1] to detach the power distribution PCB [2].

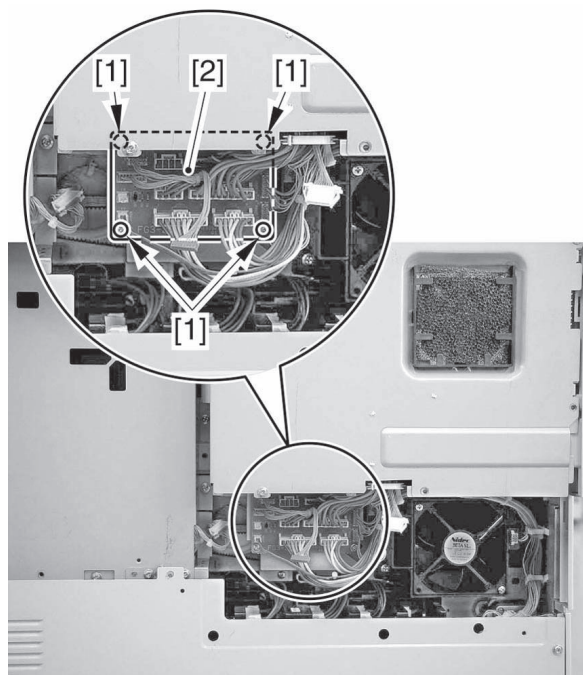

F03-411-01

4.12 Removing the HDD



When removing the HDD, be sure to take full care against damage by static discharge. Moreover, do not subject the HDD to impact.

- 1) Remove the upper rear cover.
- 2) Remove the main controller cover.
- 3) Remove the 4 screws [1] and the flat cable [2], and disconnect the connector [3]; then, detach the HDD [4].

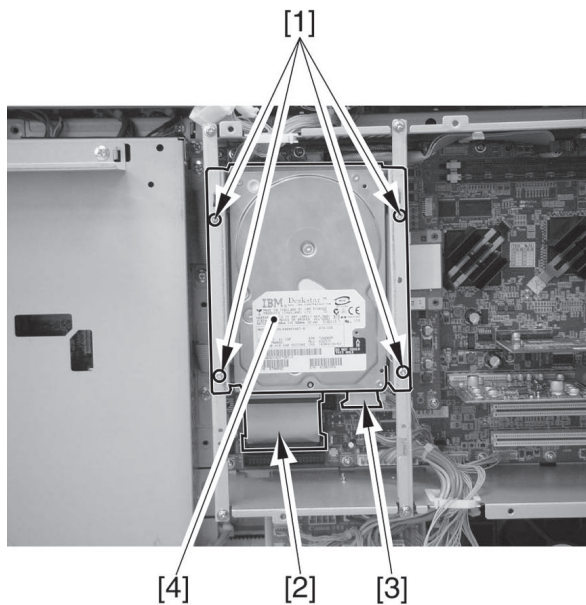

F03-412-01

4.13 After Replacing the HDD

4.13.1 If NetSpot Accountant (NSA) Is Not Used

1) Formatting the HDD

While holding down the 2 and 8 keys on the control panel, turn on the power to start up. Using the HD formatting function of the SST, format all partitions. (See Chapter 5 ‘Upgrading’ of the Troubleshooting Volume.)

2) Downloading the Software

Using the SST, download the various software (system, language, RUI). The machine will take about 10 min to start up after downloading. (See Chapter 6 ‘Upgrading’ of the Troubleshooting Volume.)

4.13.2 If NetSpot Accountant (NSA) Is Used Together with a Card Reader

The card ID used by the NSA resides on the HDD. If you have replaced the HDD, therefore, you will have to newly download the card data from NSA to enable the statistical operations of NSA. After going through steps 1) and 2) above, perform the following:

1) Set the following in service mode:

Make the following selections: COPIER>FUNCTION>INSTALL>CARD; then, enter the number of the first card, and press [OK]. (For instance, if cards No. 1 through No. 1000 are used for group control, enter ‘1’.)

2) Turn off and then on the machine; when the machine has started up, perform the following in user mode:

Make the following selections: user mode>system control settings>group ID control>count control; then, check to see that IDs from 00000001 through 00001000 have been prepared.

Make the following selections: user mode>system control settings>network settings>TCP/IP settings>IP address; then, set up ‘IP address’, ‘gateway address’, and ‘subnet mask’.

Make the following selections: user mode>system administrator setup; then, fill in ‘system control group ID’ and ‘system control ID No.’ thereafter, turn off and then on the machine.

Note:

If you leave out ‘system control group ID’ and ‘system control ID No.’, the service engineer will not be able to ‘register card to device’ as part of setup work for NSA.

3) With the machine in standby state, download the card ID to be used from NSA.

4) When the card data has been downloaded from NSA, check to see that the ID data has correctly been downloaded on the screen brought up by making the following selections:

user mode>system control settings>group ID control
(Only the downloaded ID data must be indicated.)

5) Make copies using a user card registered with NSA, and check to see that statistical operations are made for the device in question.

CHAPTER 4

INSTALLATION

1 Selecting the Site

Select the site of installation while keeping the following in mind; if possible, visit the user's premises before the delivery of the machine:

1. The place must provide a source of power that is as rated ($\pm 10\%$) and that may be used exclusively by the machine; it also must provide a terminal for grounding.
2. The place must fall within the following ranges of temperature and humidity. The site must not be near a water faucet, water boiler, humidifier, or refrigerator.

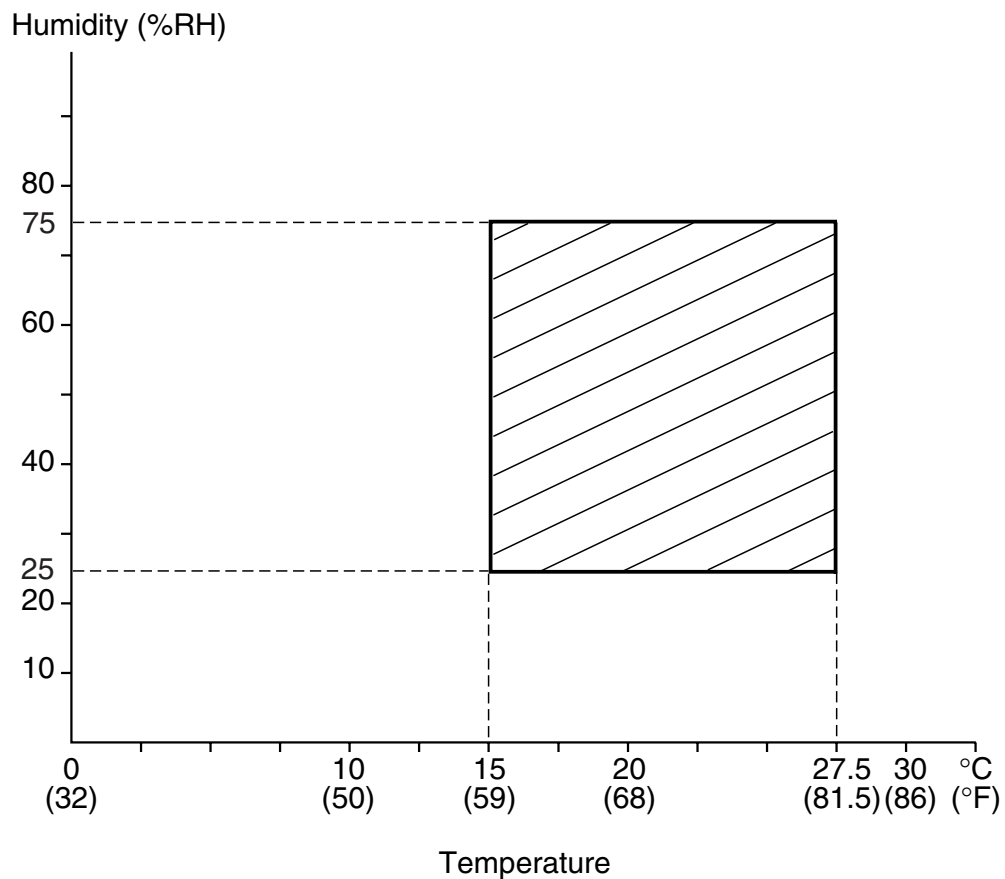

F04-100-01

3. The site must not be near a source of fire or subject to dust or ammonium gas. If exposed to direct rays of the sun, provide curtains.
4. The amount of ozone generated by the machine in operation is not of a level that would harm the health of individuals around it. Some, however, may find its odor unpleasant, requiring good ventilation for the work place.
5. Be sure that the machine's feet will remain in contact with the floor and the machine will remain level.
6. Be sure that the machine will be at least 10 cm from all walls and there will be ample space for using the machine.

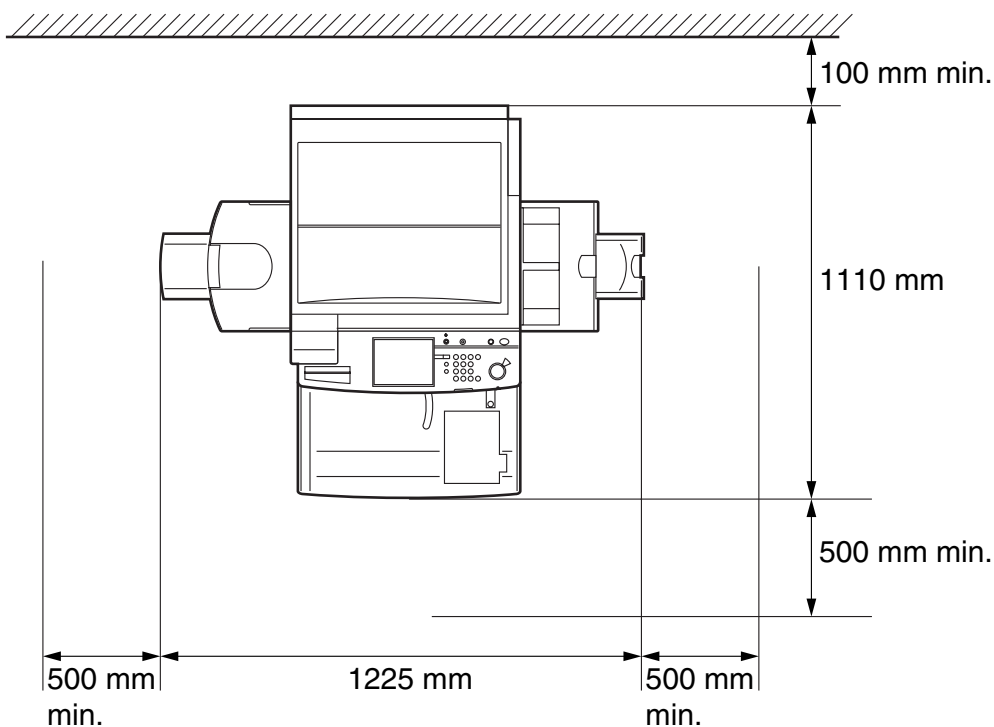

Without Options

F04-100-2

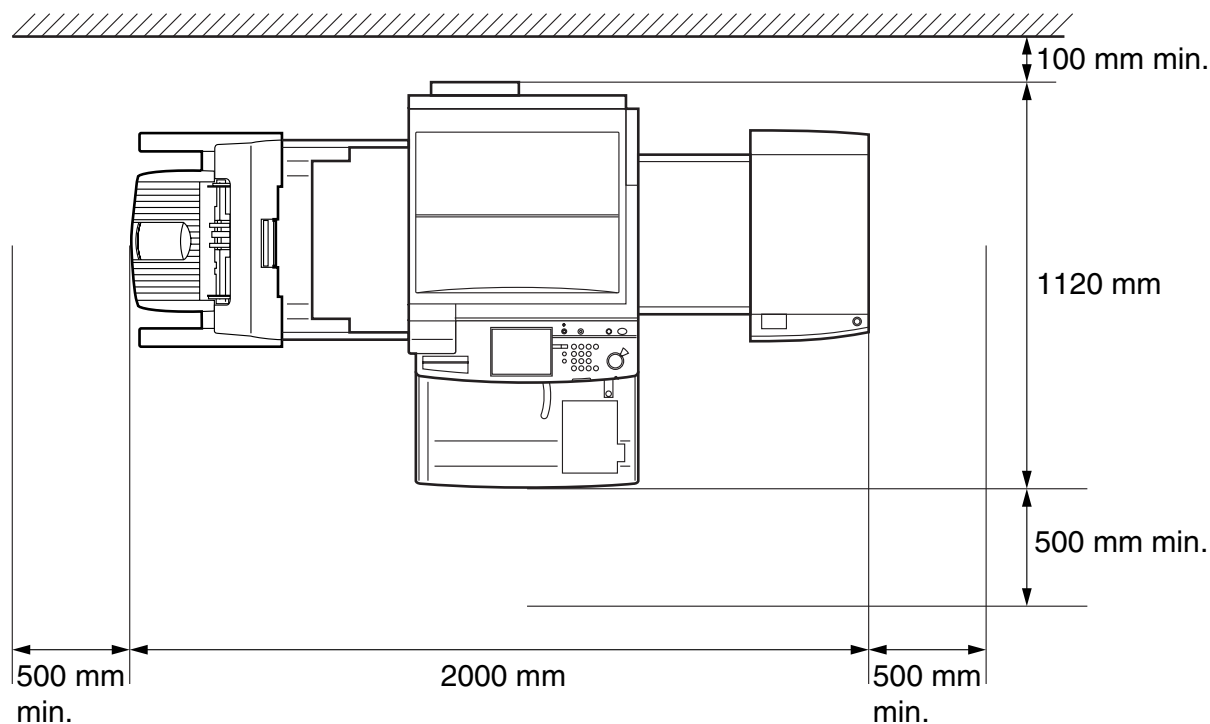

With a Finisher-N1 and Side Paper Deck-P1 Installed

F04-100-03

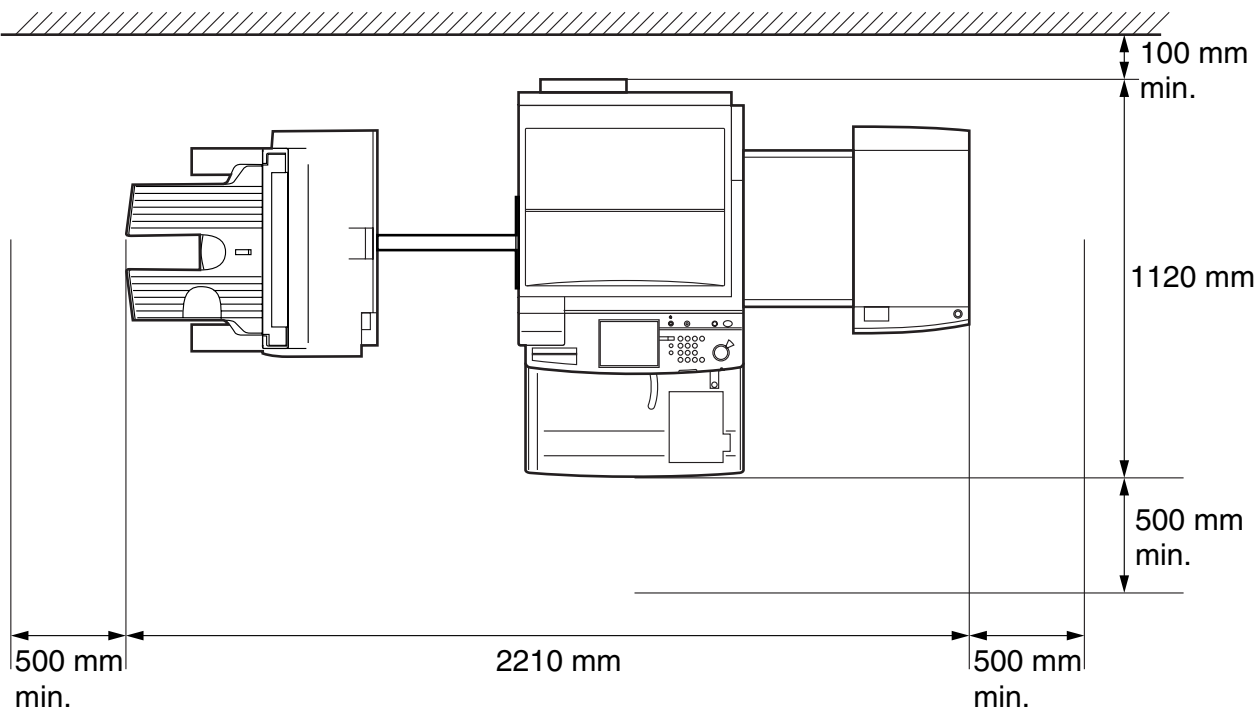

With a Finisher-N1/Saddle Finisher-N2 and Side Paper Deck-P1 Installed

F04-100-04

- The site must be well ventilated. Take care so that the machine will not be installed near a vent from which air is taken into the room.

2 Unpacking and Installation

2.1 Points to Note Before Starting the Work

Keep the following in mind when installing the machine:



-
1. If the machine is brought from a cold to warm place, condensation can occur in its optical system, laser unit, or pickup/feeder unit, leading to image faults. If such is the case, leave the machine alone without unpacking for 1 hr or more before starting the work.

The term *condensation* refers to the phenomenon that occurs on a metal surface when it is brought from a cold to warm location as the result of rapidly cooled vapor. It is seen as droplets of water on the metal surface.

2. The machine weighs about 120 kg (including the reader unit). Be sure to work in a group of 4.
-

2.2 Unpacking and Removing the Fixing Materials

- 1) Open the shipping box, and remove the plastic covers.
- If you are installing a pedestal at the same time, start with the pedestal by following the instructions in its Installation Procedure.
- 2) Remove all tape from the machine.
- 3) Slide out the upper and lower cassettes, and remove all tape; then, take out the holding plate [1].

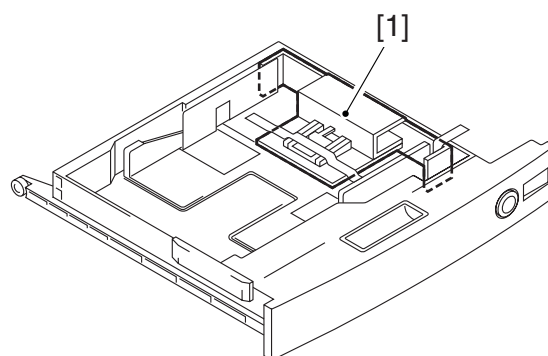

F04-202-01

- 4) Slide out the fixing feeder assembly [1] from the machine's left side.

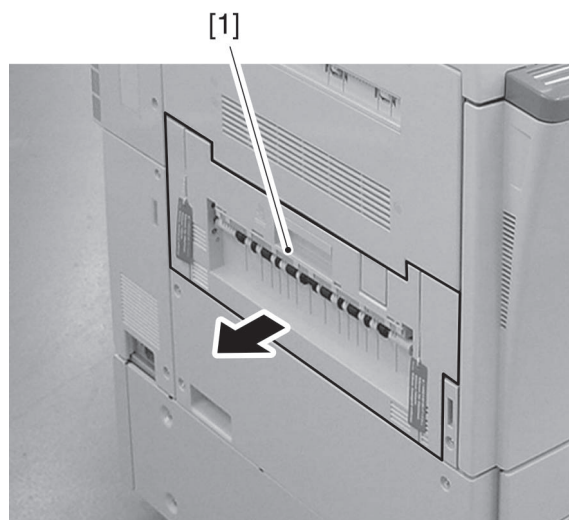

F04-202-02

- 5) Shift down the fixing roller releasing lever [1] to unlock the roller; then, remove the 2 pressure releasing clips [2] from the front/rear. (The clips will no longer be used.)

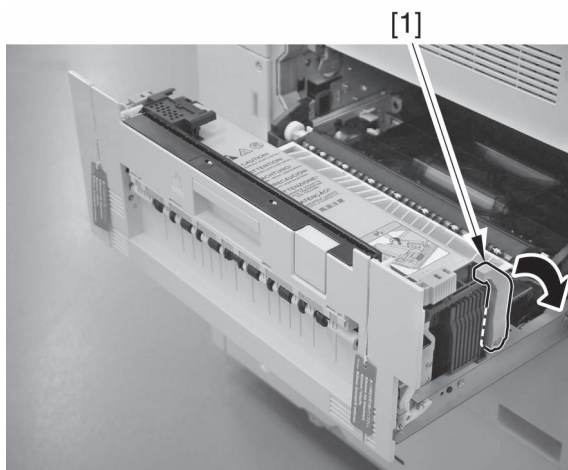

F04-202-03

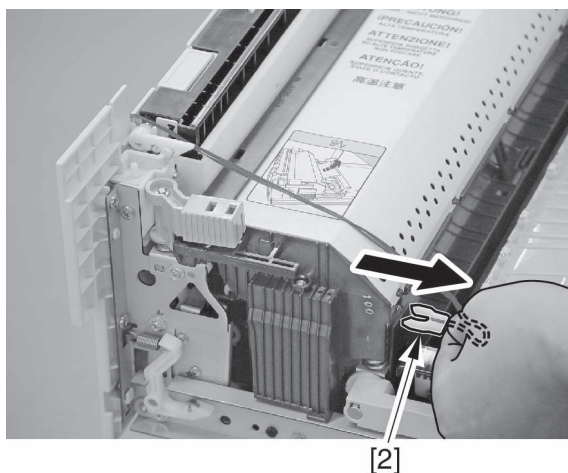

F04-202-04

- 6) Shift up the fixing roller releasing lever [1] back to its initial position; then, push in the fixing feeder assembly.

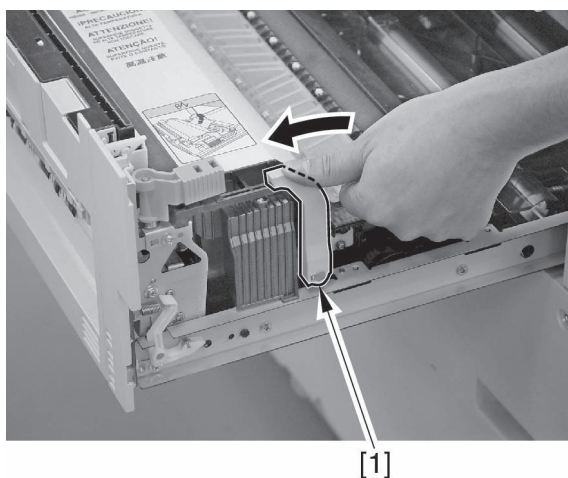

F04-202-05

- 7) Slide in the cassette.
- 8) Open the cardboard box that comes with the machine; then, check to make sure that none of the following is missing:
 0. power cord
 1. transfer cleaning unit
 2. delivery tray
 3. touch pen
 4. secondary transfer external roller unit
 5. size plate label
 6. grounding cord (100V model only)
 7. drum unit (Y/M/C/Bk)
 8. toner container (Y/M/C/Bk)
 9. User's Manual
 10. reader controller communications cable
 11. cable clamp (round)
 12. cable clamp (angular)

Note:

If the machine comes as two separate units (printer and reader), there will also be a reader connection kit in addition to the foregoing items.

2.3a Installing the Reader Unit

If the machine comes as two separate units (printer and reader), go through the following steps:

- 1) Remove the 2 screws [1] from the printer unit, and detach the center delivery tray [2]. (Save all for later.)

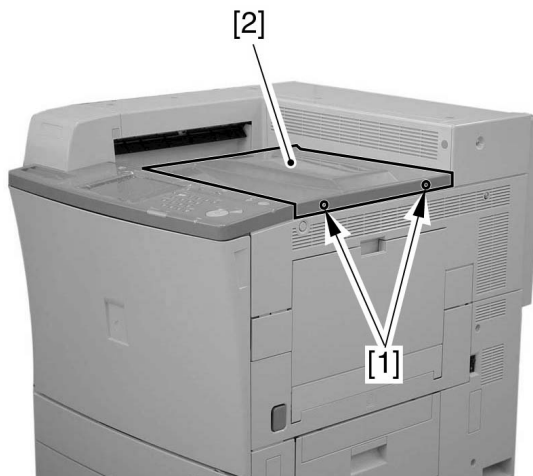

F04-203-01

- 2) Remove the face cap [1]. (Save it for later.)

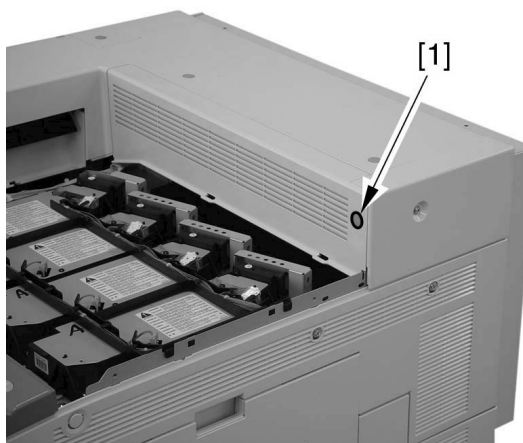

F04-203-02

- 3) Remove the screw [1], and detach the inside cover [2]. (Save it for later.)

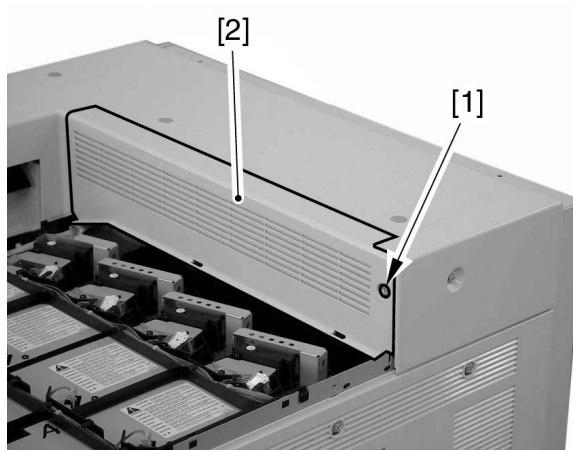

F04-203-03

- 4) Remove the screw [1], and detach the upper right cover (small) [2]. (Save the screw for later; put away the cover.)

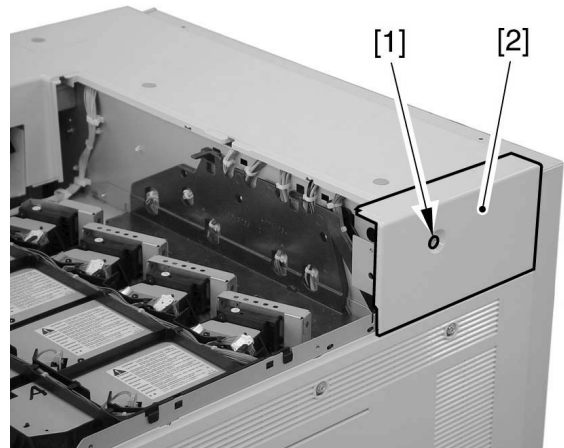

F04-203-04

- 5) Remove the face cap [1], and remove the screw [2] (1 each); then, detach the 2 small covers [3]. (Put away the cap; save the screws for later; put away the cover.)

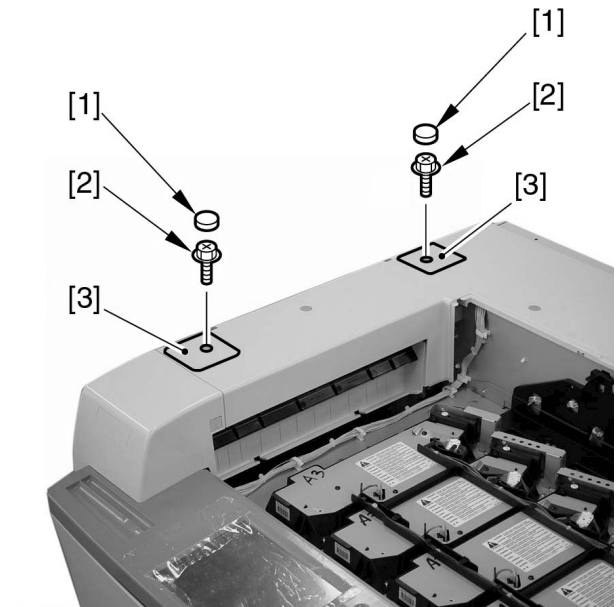

F04-203-05

- 6) Fit the included joint [1] in the hole in the machine's top as shown. (2 locations at front and rear)

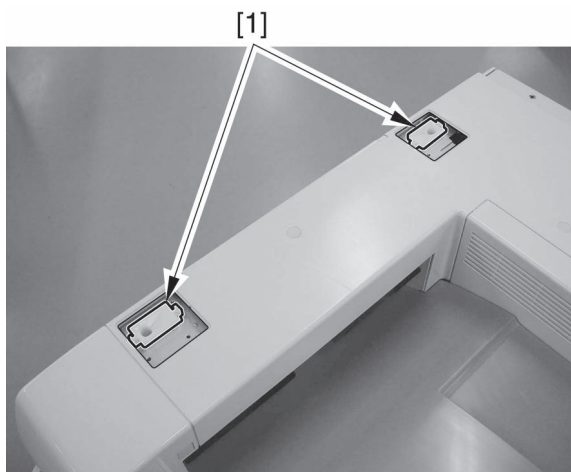

F04-203-06

- 7)



Fit it so that the sheet [1] attached to the joint plate is under the joint [2].

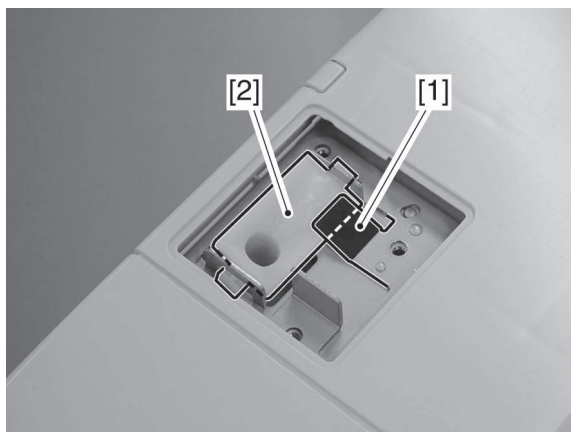

Wrong
(The sheet is above the joint.)
F04-203-07

Place the included joint plate (front)/ (rear) [3] on the front/rear joint.

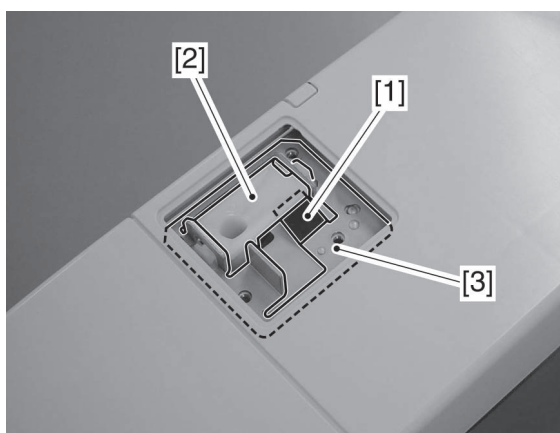

(front)
F04-203-08

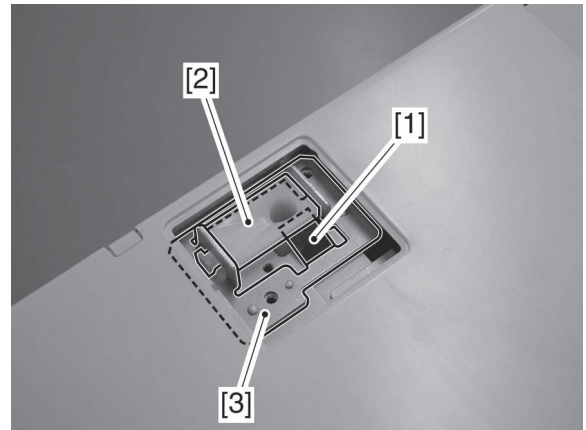

(rear)
F04-203-09

- 8) For both front and rear, secure the joint grounding spring [2] using the screw [1] removed from the small cover (for the front, tighten over the plate); then, secure the joint plate (front/rear) [4] using the 2 included screws [3] (1 each at front and rear).

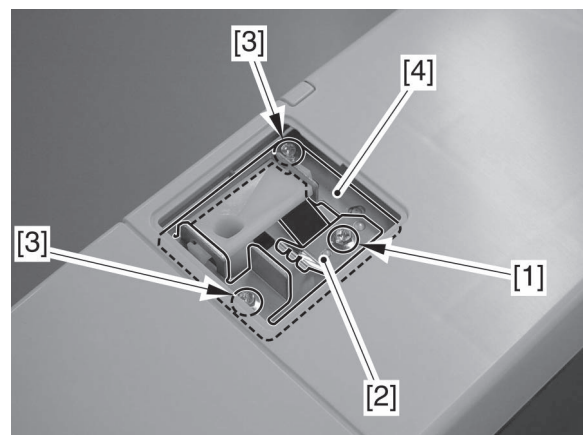

(front)
F04-203-10

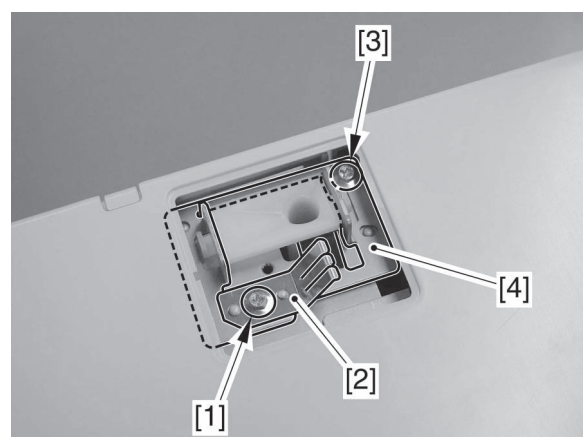

(rear)
F04-203-11

- 9) Where the upper right cover (small) has been removed, fit the positioning pin [A] for the bottom of the reader connection unit [1].

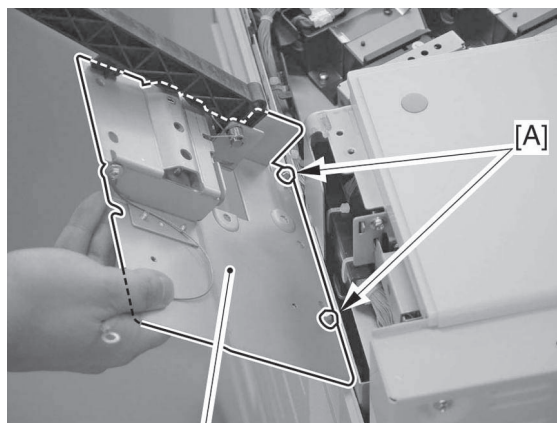

[1]

F04-203-12

- 10) Secure the reader connection unit [1] using the 2 included screws [2].

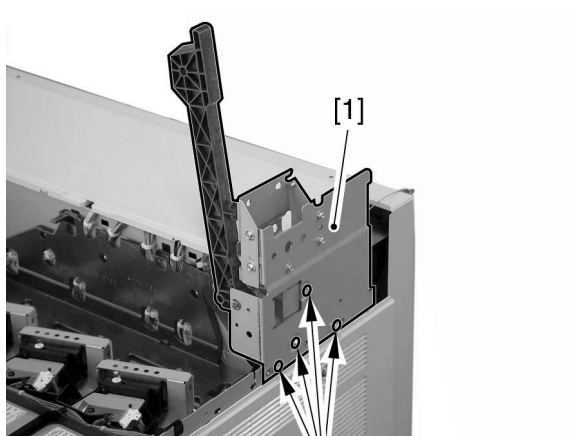

[2]

F04-203-13

- 11) Then, use the included 2 screws [1] to further secure it in place.

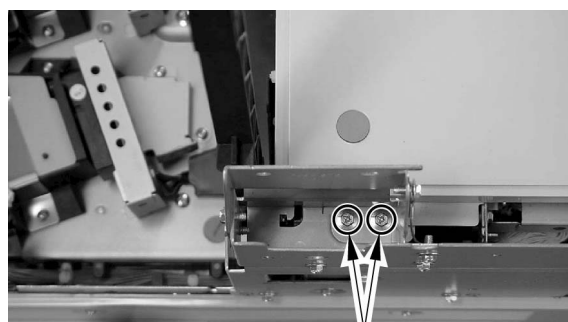

[1]

F04-203-14

- 12) Shift down the arm [1] of the reader connection unit by 90°, then, hook it on the protrusion [2] sticking out of the machine.

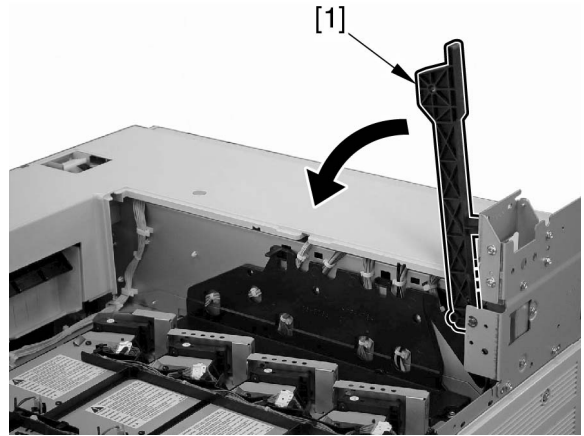

F04-203-15

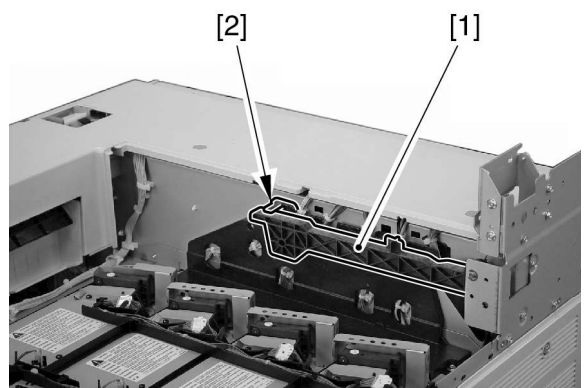

F04-203-16



When folding the arm, be sure that it is under the protrusion.

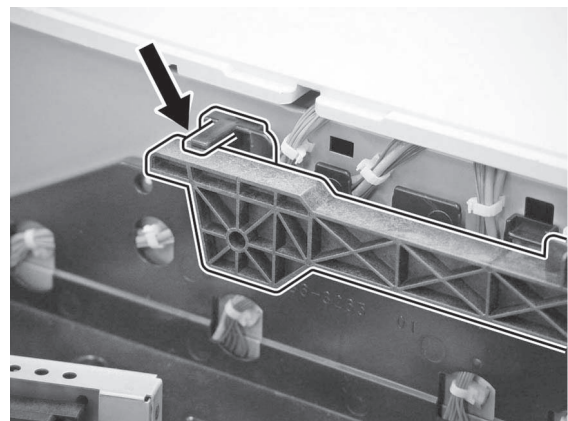

F04-203-17

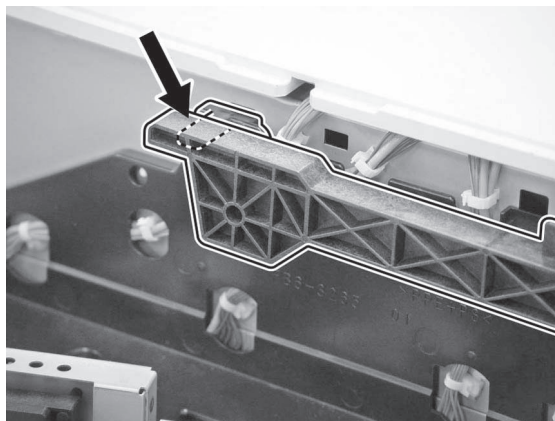

F04-203-18

13) Attach the inside cover using the 2 previously removed screws.



F04-203-19

14) Attach the center delivery tray using the 2 previously removed screws.

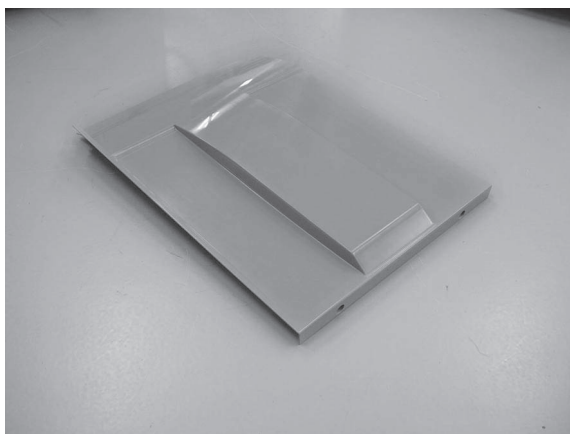

F04-203-20

- 15) Unpack the reader unit.
- 16) Place the reader unit on the printer unit 7 to 8 cm displaced to the side (temporarily).

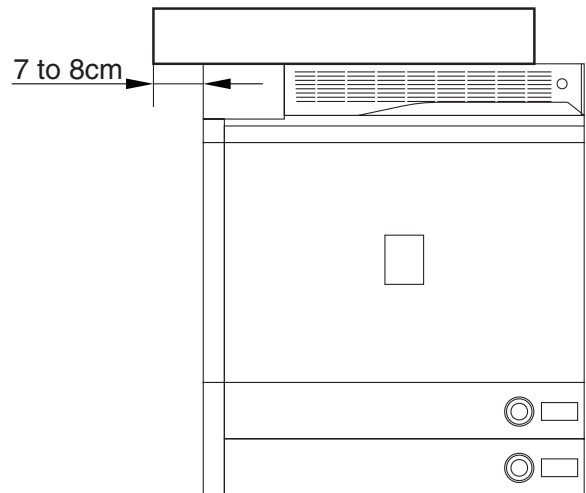

F04-203-21

- 17) Fit the included supports into the 2 holes in the bottom of the reader unit; then, tighten them firmly using a screwdriver so that they are fully fitted with the joints.

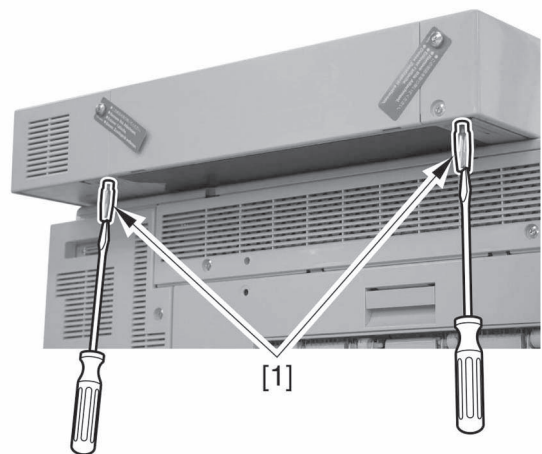

F04-203-22



F04-203-23

18) Open the delivery cover [1].

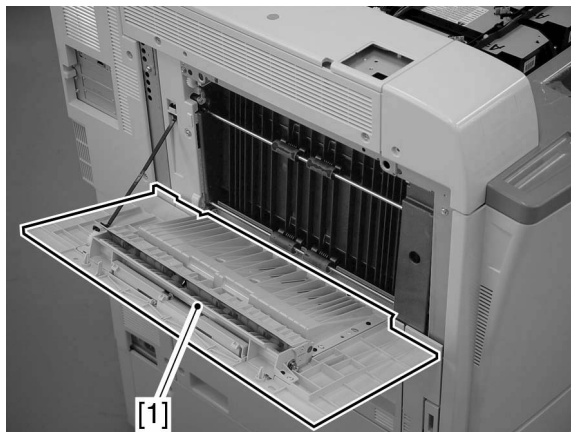

F04-203-24

19) Remove the face cap [1], and remove the 2 screws [2]; then, detach the upper left cover (small) [3]. (Save all for later.)

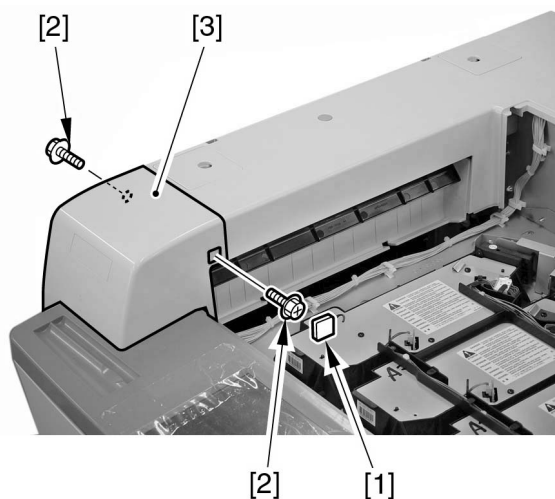

F04-203-25

20) Remove the 2 screws [1], and detach the upper left cover [2]. (Save all for later.)

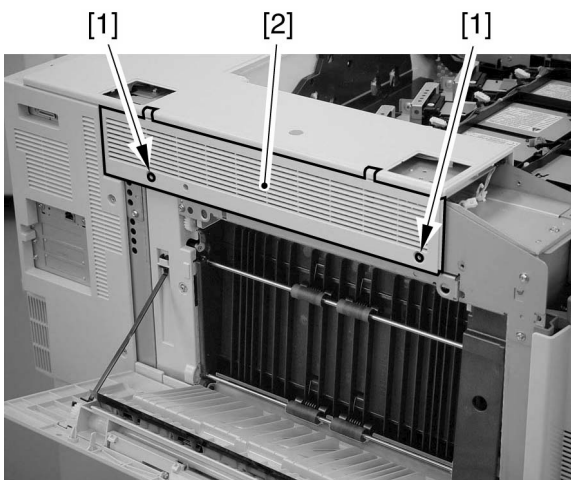

F04-203-26

21) Remove the 2 screws [1], and detach the reader left cover [2]. (Save all for later.)

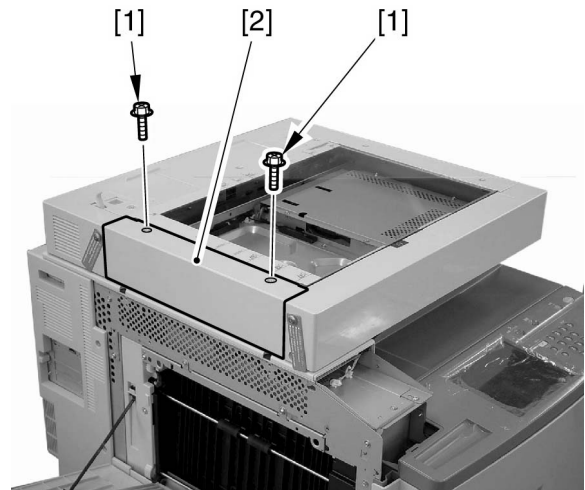

F04-203-27

22) Hook the reader unit retainer [1] on the hole in the reader unit; then, while pushing it down from above, secure it in place using the 2 included screws [2].

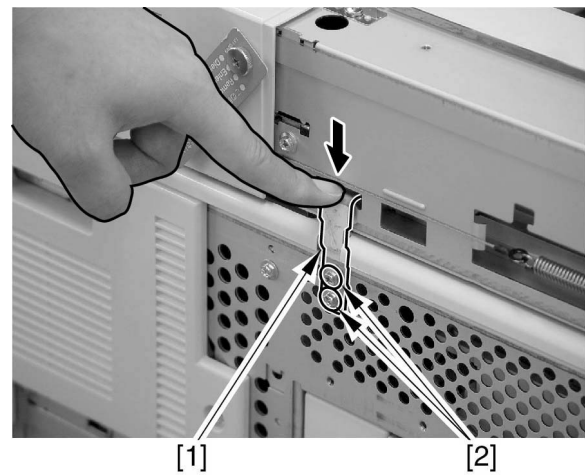

(front)

F04-203-28

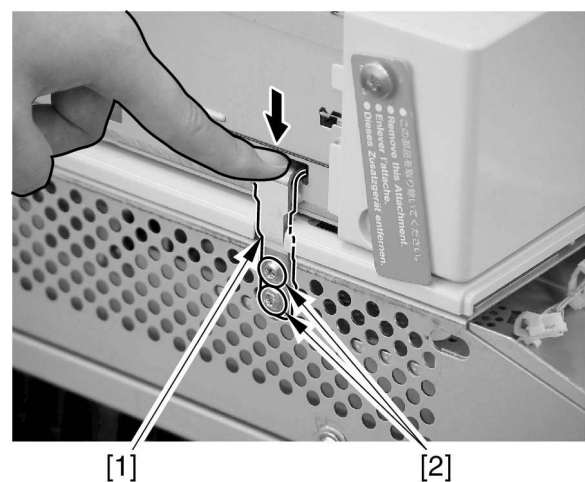

(rear)

F04-203-29

23) Bend and remove the 2 claws [1] found on the top of the removed upper left cover; then, attach them in place using the 2 previously removed screws. (Put away the claws.)

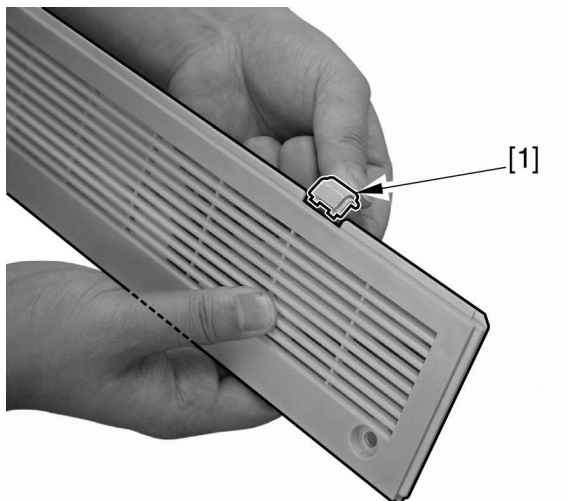

F04-203-30

24) Attach the upper left cover (small) using the 2 previously removed screws.



F04-203-31

25) Attach the reader left cover using the 2 previously remove screws.

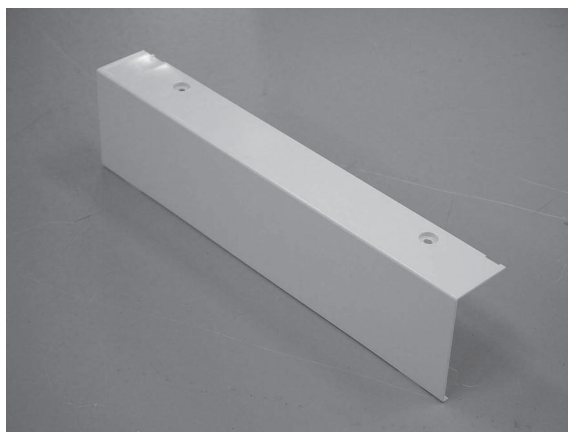

F04-203-32

- 26) Remove the 2 mirror fixing screws [1] from the left side of the reader unit.
 (Store away the removed mirror fixing screws for later, i.e., for possible relocation of the machine.)

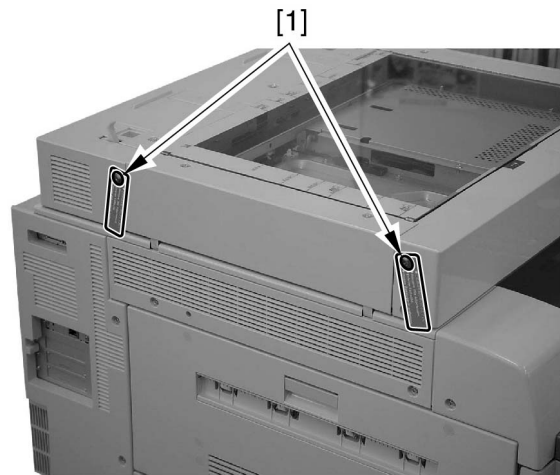

F04-203-33

- 27) Lift the reader unit slightly, and push the tip of the positioning pin [1] into the hole [2] in the reader unit.

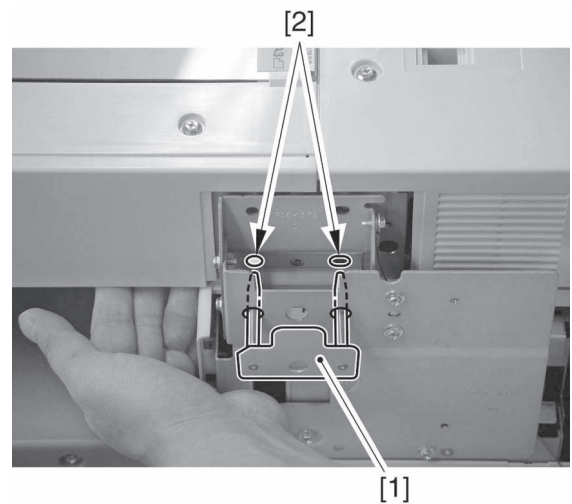

F04-203-34

- 28) When the positioning pin [1] is fully in place, secure it using the stepped screw [2].

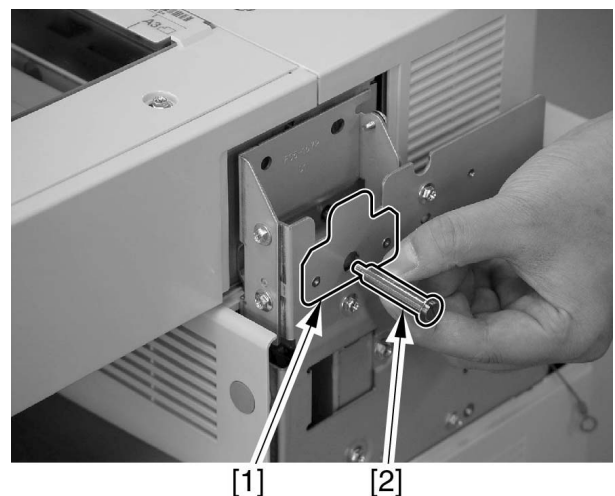

F04-203-35

29) Secure the wire [2] in place using the included RS tightening stepped screw [1].

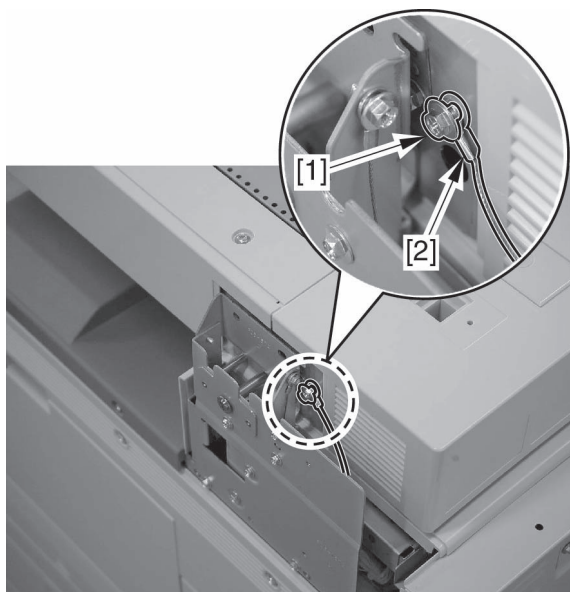

F04-203-36

30) Using the screw [1] removed from the upper right cover (small) and the included screw [2], secure the reader connection unit cover [3] in place.

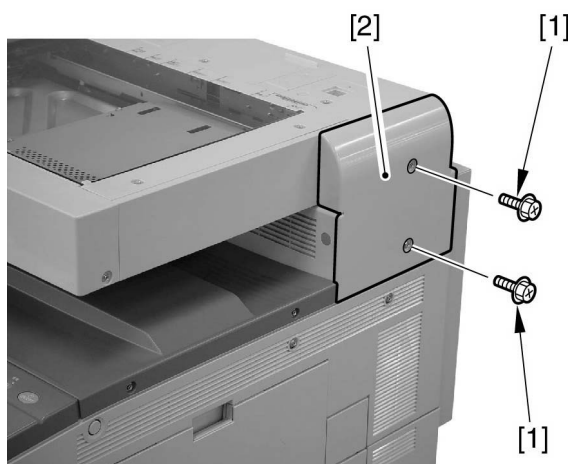

F04-203-37

2.3b Connecting the Reader Unit

- 1) Remove the 2 mirror fixing screws [1] from the left side of the reader unit. (Store them away for possible relocation of the machine.)

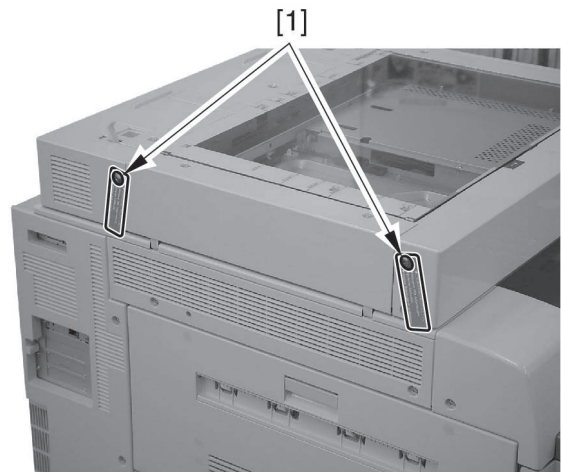

F04-203-38

- 2) Connect the included reader controller communications cable [1].

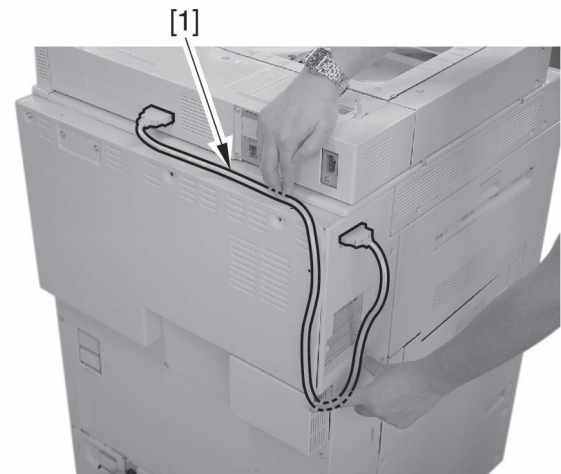

F04-203-39

- 3) Using the 5 included cable clamps (round) [1], secure the reader unit power cable [2] in place; using the cable clamp (round) [1] and the 2 cable clamps (angular) [3], secure the reader controller communications cable [4].

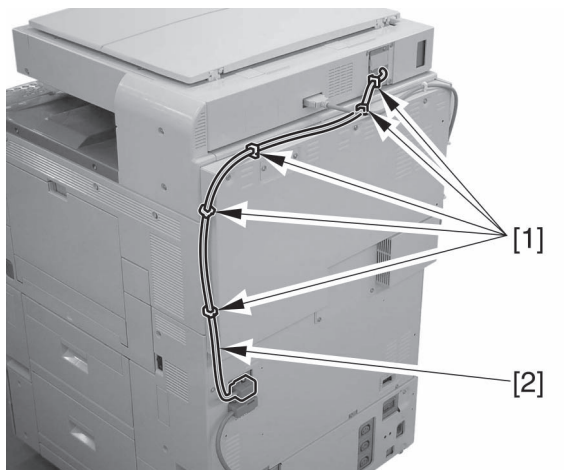

F04-203-40

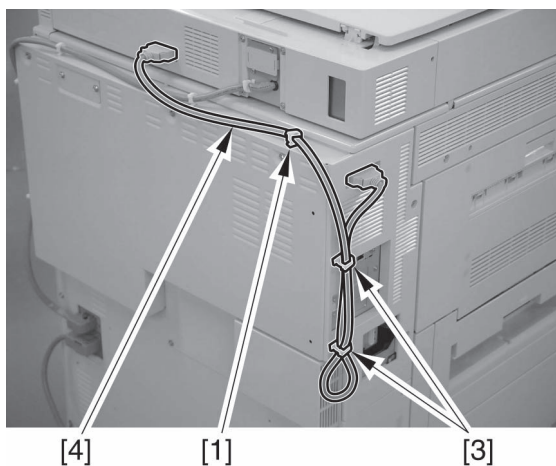

F04-203-41

2.4 Mounting the Transfer Cleaning Unit

- 1) Open the front cover.
- 2) Turn the intermediate transfer unit releasing lever [1] in the direction of the arrow.

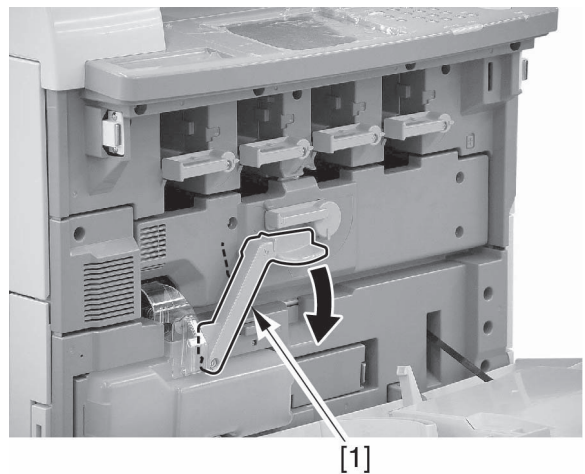

F04-204-01

- 3) Remove the waste toner container [1].

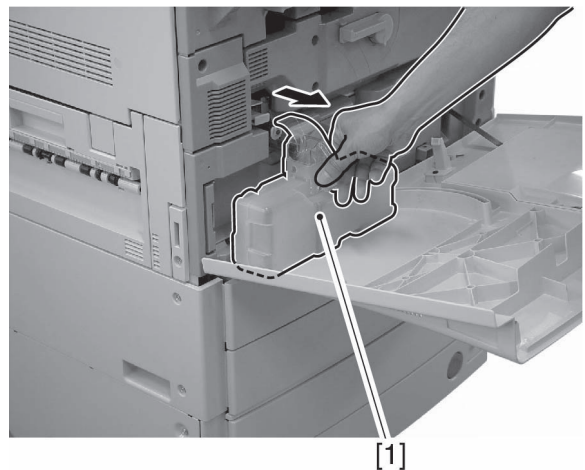

F04-204-02

- 4) Remove the screw [1], and remove the dummy transfer cleaning unit.



Be sure to store away the removed transfer cleaning unit. You will need it when executing the following service mode (for freeing the machine from condensation as needed by the site of installation):
**COPIER>FUNCTION>
 INSTALL>DRY-RT.**

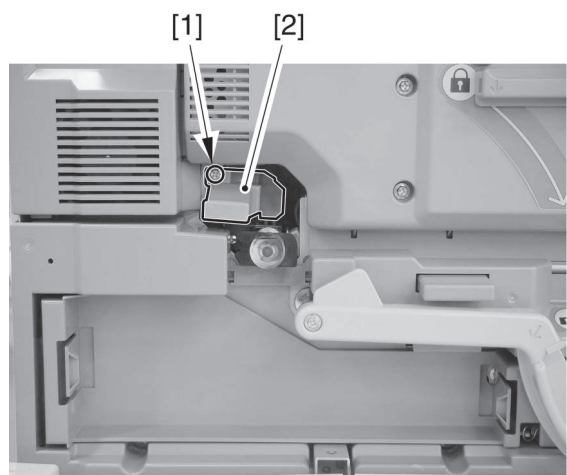

F04-204-03

5)



Do not touch the tip of the transfer cleaning unit blade. The area is coated with lubricant.

Take out the included transfer cleaning unit from the bag, and remove the packing material (cardboard).

- 6) Using the included binding screw [1], mount the transfer cleaning unit [2]. (Be sure to match the protrusion on the top of the waste toner feedscrew case with the groove in the base of the transfer cleaning unit.)

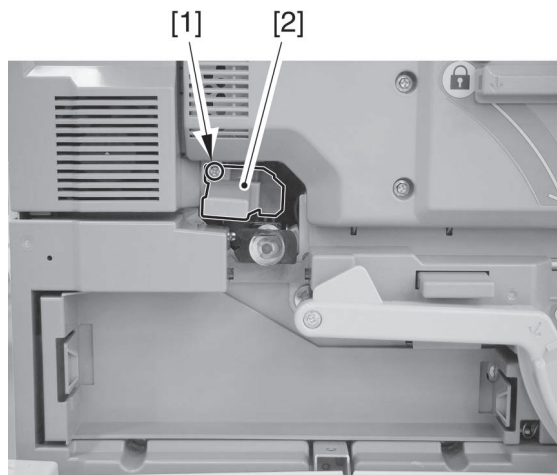

F04-204-04

- 7) Fit the waste toner container.
8) Shift back the intermediate transfer unit releasing lever back to its initial position.

2.5 Fitting the Toner Container



Each toner container has its specific position according to color (viewing from the control panel and starting at the left, Y, M, C, and Bk). Do not force the wrong container into place.

- 1) Take out the toner container (Y) from the packing box.
- 2) Take out the toner container (Y) from the packing bag; then, leave it alone for a while until it becomes used to the ambient temperature.
- 3) Turn the fixing lever [1] of the toner container (Y) 90° clockwise.

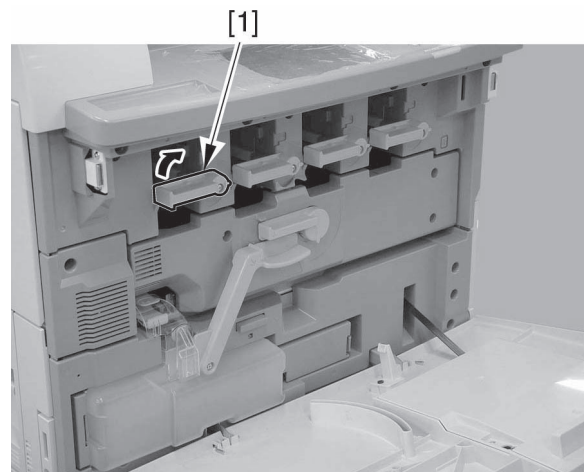

F04-205-01

- 4) Holding the toner container (Y) [1] with both hands, move it several times as if to rotate it.

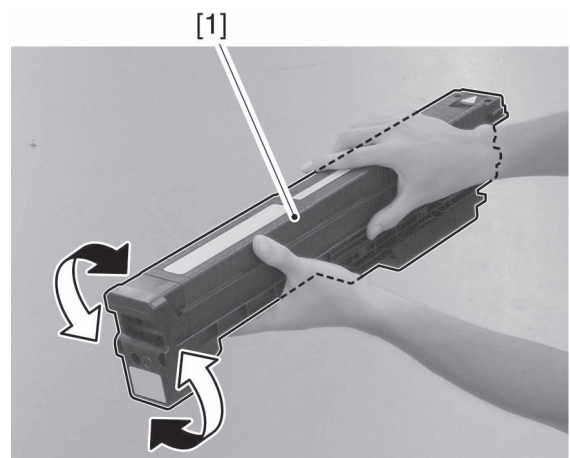

F04-205-02

- 5) Push it all the way in the direction of the arrow indicated on the top edge.

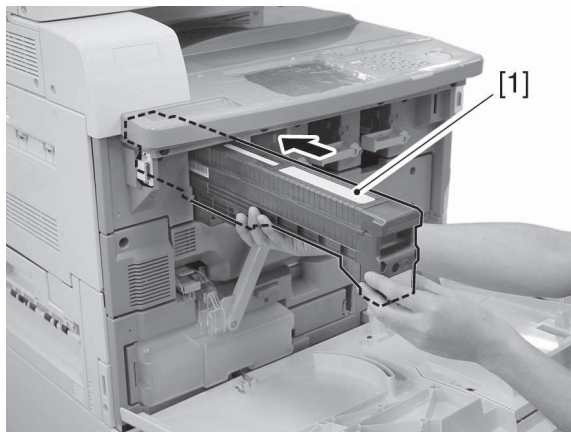

F04-205-03

- 6) Shift the fixing lever of the toner container (Y) back to its initial position (by turning it counterclockwise by 90°).
- 7) Fit the rest of the toner containers (M, C, Bk) in the same way.

2.6 Fitting the Drum Unit

- 1) Take out the drum unit (Y) from the packing box.
- 2) Take out the drum unit (H) [1] from the packing bag; then, take out the drying agent (silica gel).

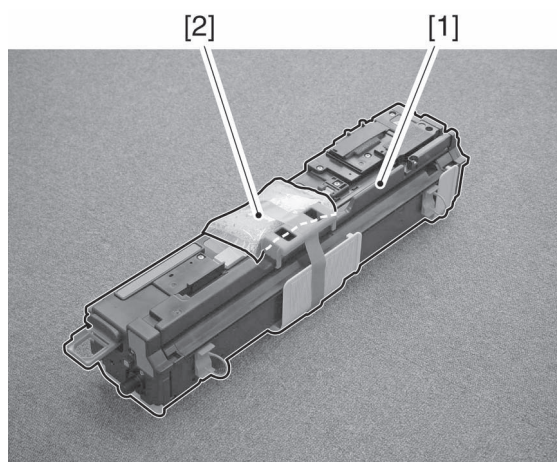

F04-206-01

3)



Do not remove the protective cover. It serves as a rail.

Pull out the pressure releasing hook [1] at the front and the rear.

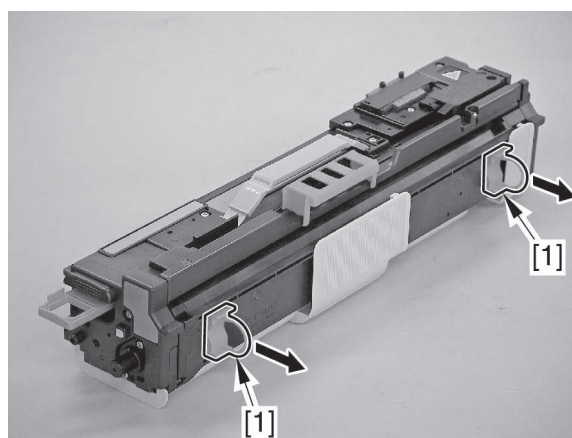

F04-206-02

- 4) Remove the anti-interference sheet [1].

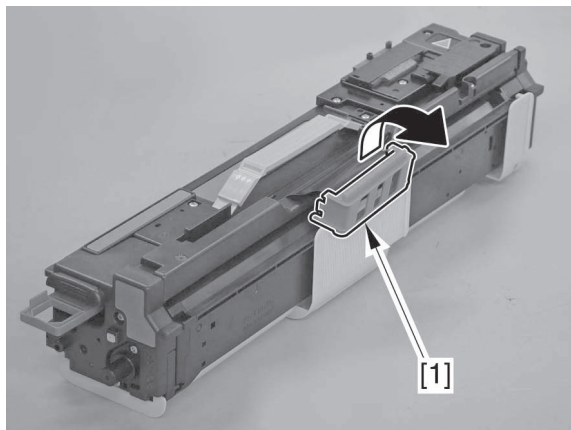

F04-206-03

- 5) Turn the intermediate transfer unit releasing lever [1] in the direction of the arrow.

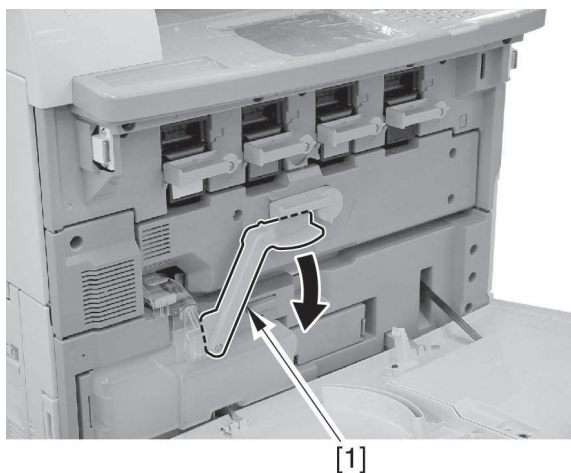

F04-206-04

- 6) Turn the open/close lever [2] of the cartridge cover [1] clockwise by 90° to open the cartridge cover.

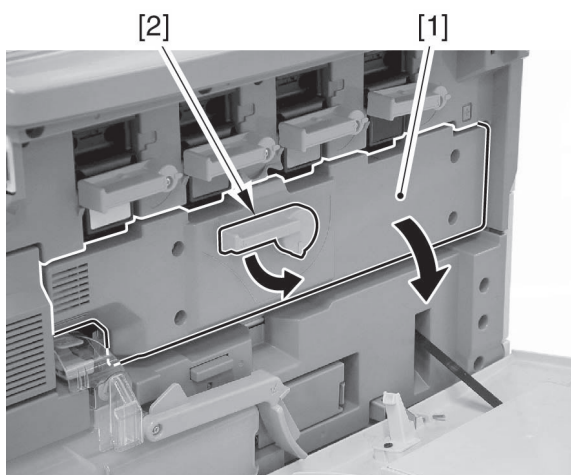

F04-206-05

- 7) Match the groove [1] found behind the machine's cartridge cover and the protrusion [2] found on the bottom of the protective cover; then, secure them in place.

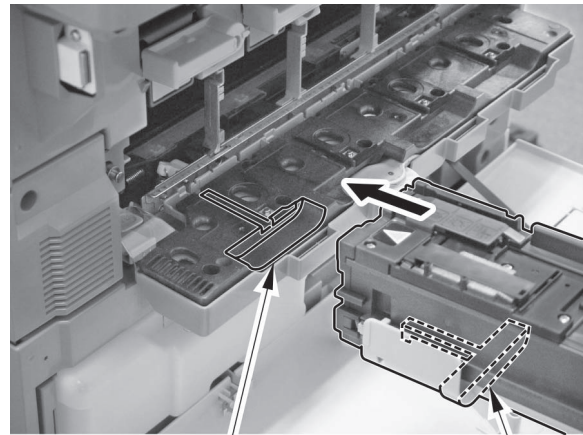

[1]

[2]

F04-206-06

8)



1. Push the drum cartridge in the direction of the arrow [1] indicated on its top edge.
2. Store away the protective cover after fitting the drum cartridge.

While supporting the protective cover [2] with your hand, push in the cartridge (Y) [3], thereby setting it in place (Y, M, C, and Bk starting from left).

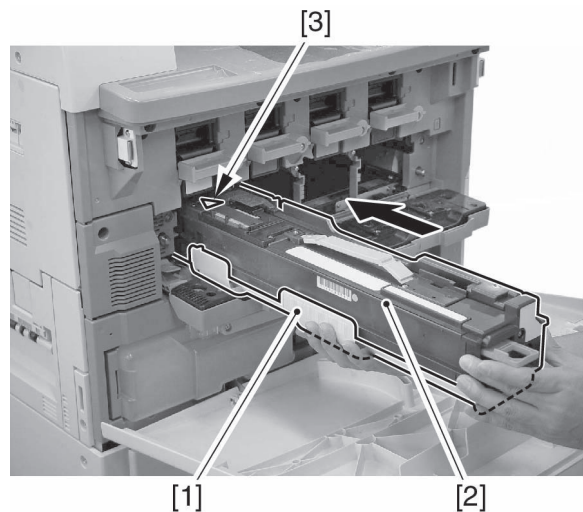

[1]

[2]

[3]

F04-206-07

9)



When pulling out the sealing tape, be sure to hold the drum cartridge with your hand so that the cartridge will not slip off.

Pull out the sealing tape [1].

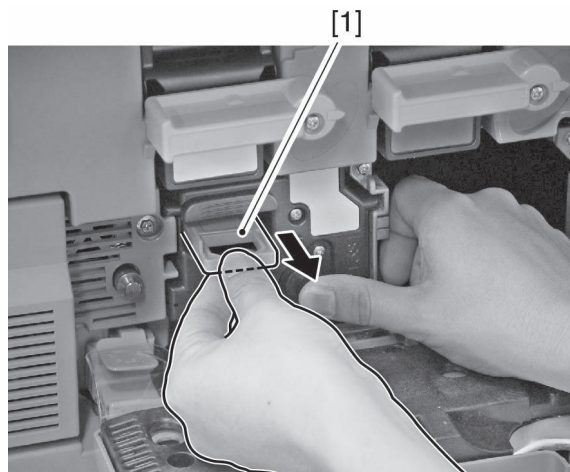

F04-206-08

- 10) Fit the M, C, and Bk drum cartridges in the same way.
- 11) Close the cartridge cover, and turn the open/close lever clockwise to set it in place.
- 12) Shift the intermediate transfer unit releasing lever back to its initial position.
- 13) Close the front cover.

2.7 Setting Up the Cassette

- 1) Press the cassette releasing button, and slide out the cassettes to the front.
- 2) Check the type of paper used by the user; then, set the slide guide [1] of the cassette to suit the size of the paper.

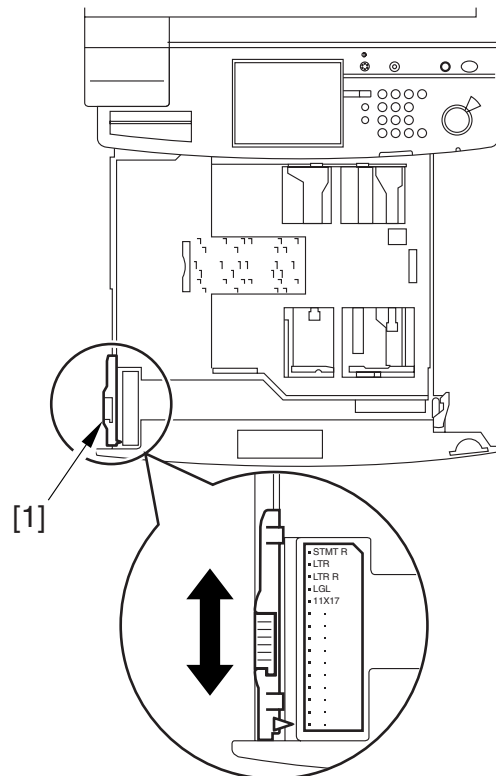

F04-207-01

- 3) Pick the levers of the side guide plate [1] and the trailing edge plate [2]; then, move them to suit the appropriate paper size index.

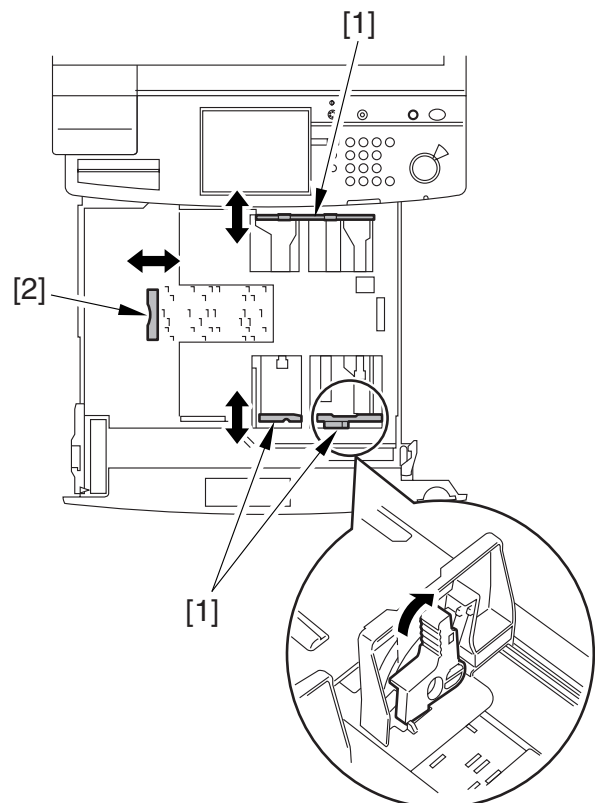

F04-207-02

- 4) Attach the size label [2] to the cassette size plate [1]: then, set the plate to the cassettes.

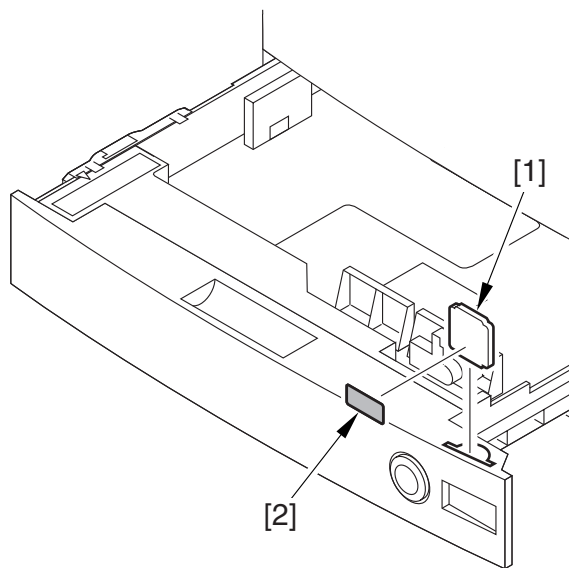

F04-207-03

- 5) Put paper to the cassettes, and set them in the machine.

2.8 Connecting to the Network

 Perform the following only if the model is equipped with printer functions.

- 1) Turn off the machine's main power.
- 2) Connect the network cable to the machine, and turn on the main power.
- 3) Inform the user's system administrator that the machine has been installed, and ask to make network settings.

2.9 Checking the Connection to the Network

 Perform the following only if the model is equipped with printer functions.

If the user's network is based on the TCP/IP, use the PING command to make sure that the Ethernet PCB has correctly been mounted and that the network has correctly been set up.

If the user's network is based on the IPX/SPX or AppleTalk, you need not make this check.

2.9.1 Using the PING Command

- 1) Select 'PING' in service mode:
COPIER>TEST>NETWORK>PING.
- 2) Using the keypad on the control panel, type in the IP address, and press [OK].
- 3) Press the Start key.
 - If the check by the PING command ends successfully, 'OK' will be indicated; otherwise, 'NG' will be indicated.

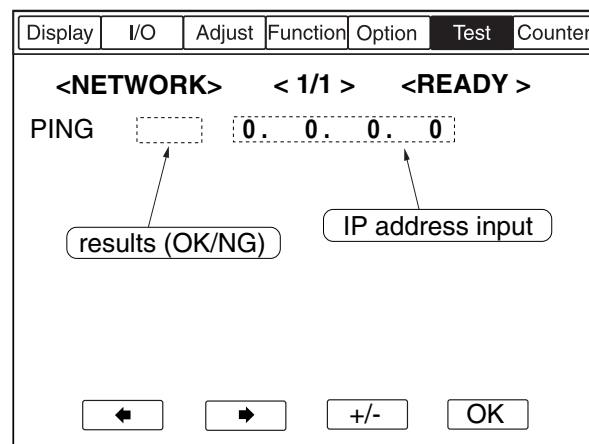

F04-209-01

2.9.2 Making a Check Using a Remote Host Address

You can execute a PING command using a remote host address, thereby checking the connection to the network.

The term remote host address is used to refer to a PC terminal connected to and operating under a TCP/IP network to which the machine is connected.

- 1) Inform the user's administrator that you will be checking the connection to the network using a PING command.
- 2) Obtain the appropriate remote host address from the user's system administrator.
- 3) Enter the remote host address under 'PING'.
- 4) If the result is 'OK', the machine is correctly connected to the network.
- 5) If the result is 'NG', the machine is not correctly connected to the network; go through the following troubleshooting steps:

2.10 Troubleshooting the Network



Perform the following steps only if the model is equipped with printer functions.

If the connection to the network fails, the following causes can be suspected; follow the instructions under 2.12.1 and thereafter to correct the fault:

- a. the connection between the network and the Ethernet PCB is poor.
- b. the TCP/IP setting of the machine is not correct.
- c. the Ethernet PCB is faulty, or the PCB is not properly mounted.
- d. the user's network is faulty.

2.10.1 Checking the Connection of the Network Cable

- 1) Check to see if the network cable is correctly connected to the Ethernet PCB.
 - if correct, go to 2.12.2.
 - if not correct, try a check once again using a remote host address.

2.10.2 Making a Check Using a Loopback Address

A loopback address will be returned by the network PCB; as such, you can find out whether the TCP/IP settings of the machine are correct or otherwise by executing the PING command using a loopback address.

- 1) Enter the loopback address (127.0.0.1) under 'PING'.
 - if 'NG', check the TCP/IP settings of the machine once again, and execute the PING command once again.
 - if 'OK', make the check under 2.12.3.

2.10.3 Making a Check Using a Local Host Address

A local host address here is the IP address of the machine, and the PING command executed using the address will be returned by the network PCB, enabling you to find out whether the network PCB is faulty or otherwise.

- 1) Enter the machine's IP address under 'PING'.
 - If 'NG' is indicated, make the following checks and take the following action; then, execute the PING command once again.
 - a. if the machine's IP address is faulty, check the machine's IP address settings once again/check with the user's system administrator to find out whether the assigned IP address is valid.
 - b. if the network PCB has poor connection, check the connectors of the network PCB.
 - c. if the network PCB is faulty, replace the network PCB.
 - if 'OK' is indicated, suspect a fault in the user's network environment; report to the user's system administrator for remedial action.

2.11 Checking the Images/Operations

Place a test sheet on the copyboard glass, and select the cassette 1/2 as the source of paper; then, make copies, and check the images.

(If a 2-cassette pedestal is used, try cassette 3/4 to check images.)

- Check to be sure there is no abnormal noise.
- Check to be sure that the images are free of faults at all default reproduction ratios.
- Check to make sure that as many copies as are specified are made without a problem.
- If the images are not normal, make adjustments according to the instructions under the Image Adjustment Basic Procedure.
- Check to make sure that the margin (L2) to the front of the copies made with each of the cassettes as the source of paper is 2.0 ± 1.5 mm; otherwise, make the following adjustments:
 - 1) Slide out the manual feed unit and the cassette 1/2; then, open the pickup vertical path cover. (In the case of a 2-cassette pedestal, cassette 3/4.)
 - 2) Remove the 2 screws [1], and detach the right front cover [2]. (Do the same also for a 2-cassette pedestal.)

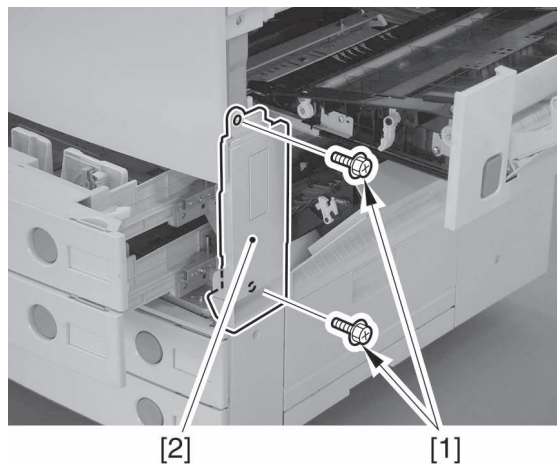

F04-211-01

- Making Adjustments for Cassette 1
 Inert a screwdriver through the hole in the right front stay, and loosen the screw [1] to adjust the position of the adjusting plate [2]. (Do the same for cassette 3/4.)

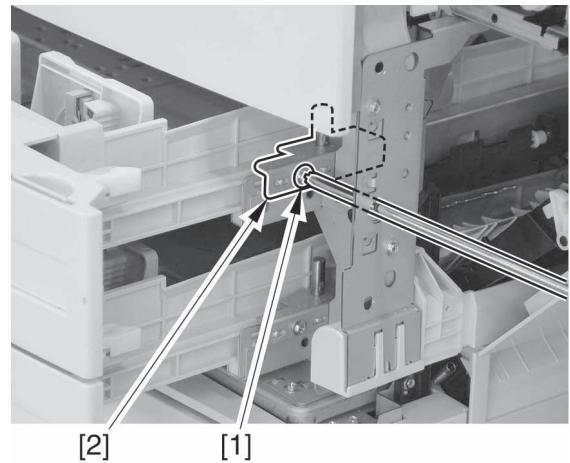

F04-211-02

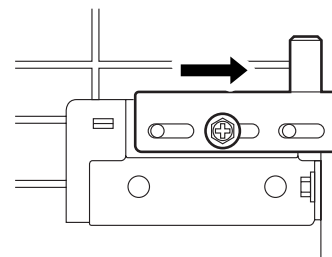

If the adjusting plate is moved to the right,

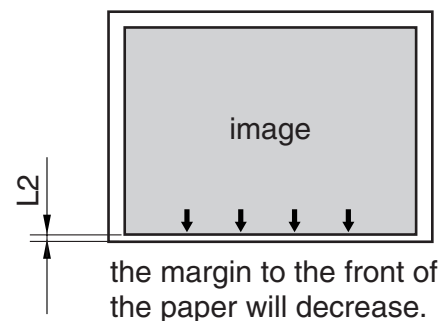

F04-211-03

- Making Adjustments for Cassette 2
 3) Remove the grip [1] on the front right.

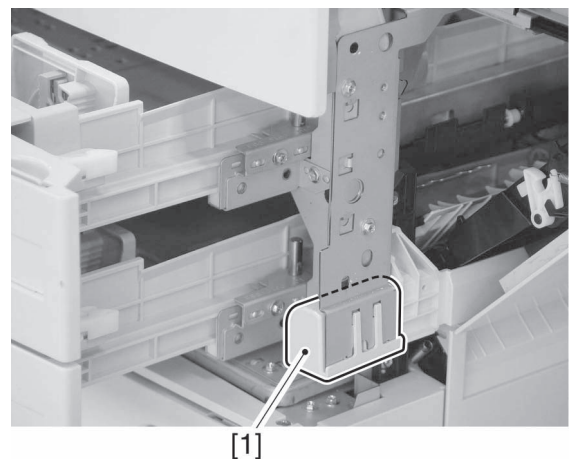

F04-211-04

- 4) Insert a screwdriver through the hole in the right front stay, and loosen the screw [1] to adjust the position of the adjusting plate [2].

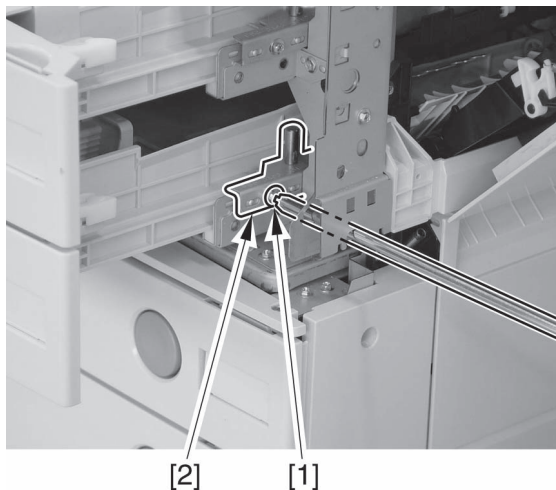

F04-211-05

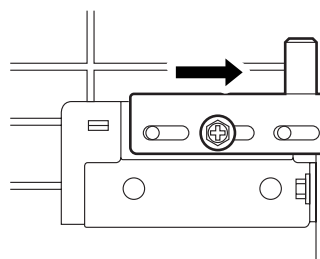

If the adjusting plate is moved to the right,

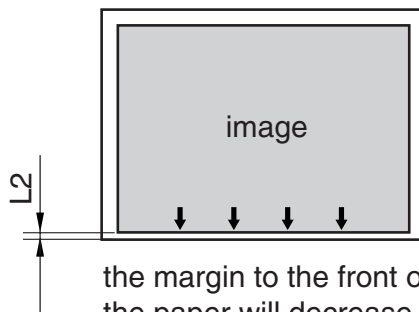

the margin to the front of the paper will decrease.

F04-211-06

- Check to make sure that the margin (L1) along the leading edge of paper picked from each of the cassettes is 2.5 ± 1.5 mm; otherwise, make the following adjustments:
 - 1) Make the following selections in service mode: COPIER>ADJUST>FEED-ADJ.
 - 2) Change the setting to make adjustments. (A change by '1' will cause a shift of 0.1 mm; a higher value will move the image toward the leading edge of the paper.)

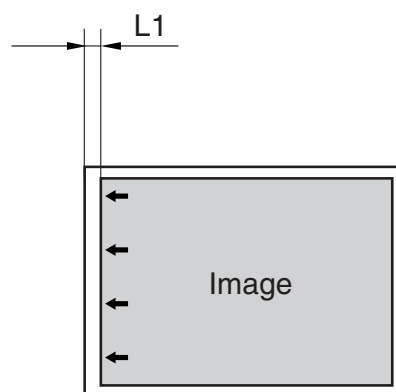

An increase in the value of FEED-ADJ will move the image toward the leading edge of the paper.

F04-211-07

- Adjusting the Image Area (non-image width)
 - 1) Make the following selections in service mode: COPIER>ADJUST>BLANK.
 - 2) Check to make sure that the setting is as follows:
- If a line is found in the output image, go through the following:
 - 1) Make the following selections in service mode: COPIER>CCD>SH-PS-ST.
 - 2) Press the OK key so that the indication on the screen will change to 'ACTIVE', indicating that the machine is executing automatic adjustment of shading position.
- If 'OK' is indicated on the screen,
 - 3) See that auto adjustment has ended.
- If 'NG' is indicated on the screen,
 - 4) Make the following selections in service mode: COPIER>ADJUST>ADJ-XY>ADJ-S.
 - 5) Change the setting to adjust the shading position.

2.11.1 PASCAL Setting

- 1) Make the following selections in service mode: COPIER>OPTION>BODY>PASCAL.
- 2) Check to make sure that the setting is '1'.
- 3) Press the Reset key several times to end service mode.
- 4) Make the following selections in user mode: adjust/clean>auto gradation correction.
- 5) Press [test print 1] to generate test print 1.
- 6) Place the test print 1 output on the copyboard glass, and have the machine read it.
- 7) Press [test print 2] to generate test print 2.
- 8) Place the test print 2 output on the copyboard glass, and have the machine read it.
- 9) Press [test print 3] to generate test print 3.
- 10) Place the test print 3 output on the copyboard glass, and have the machine read it.

When all work is done, turn the adjuster on the bottom of the pedestal to secure the machine in place.

3 Relocating the Machine

3.1 Preparing for Relocation

If the machine must be relocated after installation, be sure to perform the following work before relocation:



Do not use the machine's grips when moving it over a step while it is on a pedestal; otherwise, the machine and the pedestal may separate. Be sure to hold the pedestal.

- 1) Fix the scanner in place using the scanner fixing screw [1] removed and stored at time of installation.

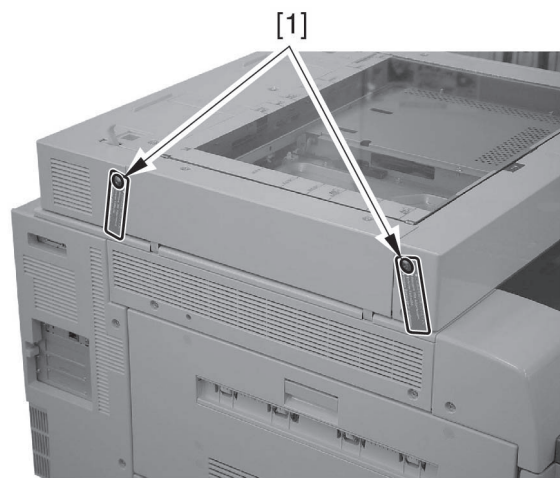

F04-301-01

- 2) Put ten sheets of papers [1] on the copyboard glass.

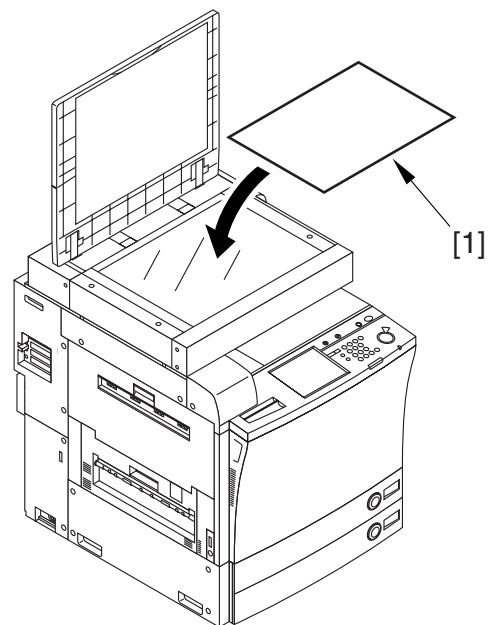

F04-301-02

4 Installing the Card Reader-D1

4.1 Checking the Contents

Open the shipping box, and check to make sure none of the following is missing:

- [1] Card Reader-D1 1 unit
- [2] Pan-head screw (small) 1 pc.
- [3] Binding screw (M4) 1 pc.

4.2 Installation Procedure

- 1) Remove the face cap [1] and 2 screws [2]; then, detach the upper left cover (small) [3].

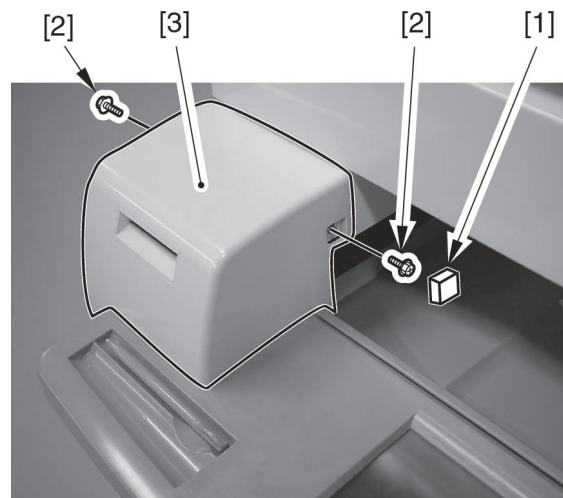

F04-402-01

- 2) Remove the 3 screws [1] from behind the upper left cover (small), and detach the inside cover [2]; then, attach it as shown (by changing its orientation).

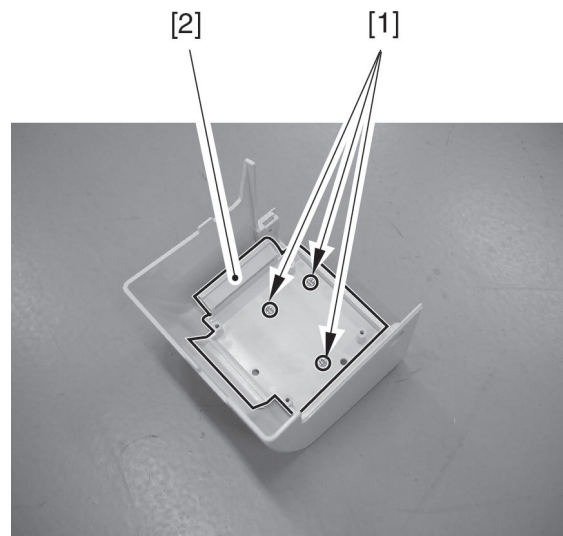

F04-402-02

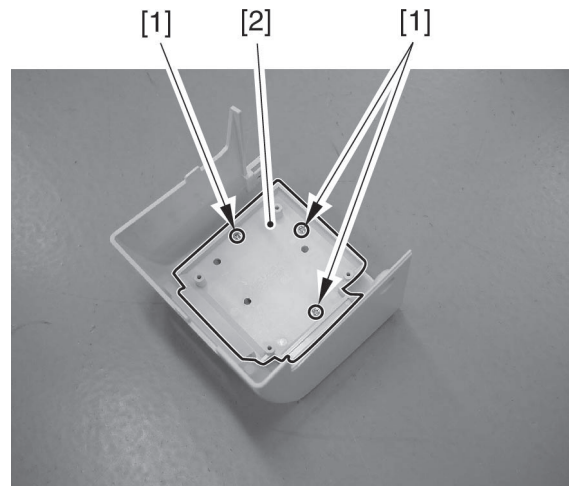

F04-402-03

3)



When attaching, be sure that a card may be inserted with the label on the face side.

Using the 4 included binding screws [1], mount the card reader [2] to the inside cover.

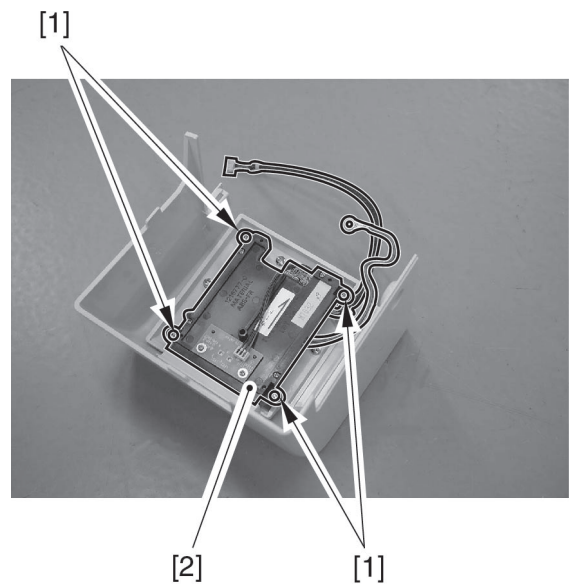

F04-402-04

- 4) Secure the grounding wire [1] in place using the included pan-head screw (small) [2]; then, connect the connector [3] of the card reader to the machine's connector.

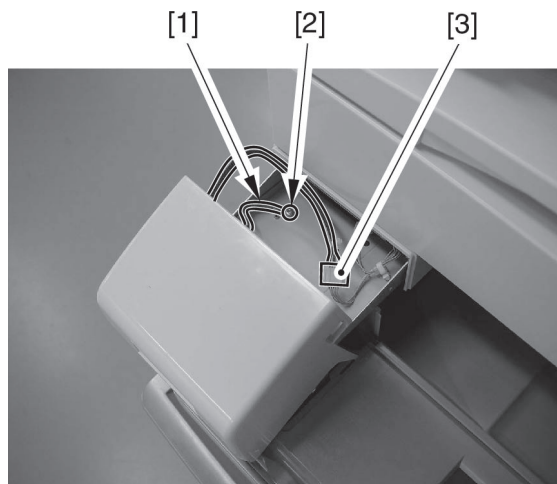

F04-402-05

- 5) Attach the upper left cover (small) using the previously removed screw.
- 6) Turn on the main power switch, and make the following selections in service mode:
COPIER>FUNCTION>INSTALL>
CARD.
Then, enter any number (from 1 to 2000) to serve as the number to identify the first card used by the user.
- 7) Turn off and then on the main power switch.

4.3 Making Settings If Net Spot Accountant (NSA) Is Used

- 1) Check to make sure that IDs (from ID00000001 through ID00001000; i.e., if '1' is entered in COPIER>FUNCTION>INSTALL>CARD in service mode) have been prepared in user mode (system control settings>group ID control>count control).
- 2) Set up the following in user mode (system control settings>network settings>TCP/IP settings>IP address): 'IP address', 'gateway address', 'subnet mask'.
- 3)



If you fail to set up 'system control group' and 'system control ID No.', you will not be able to execute 'register card to device' when setting up NSA.

Enter any number for 'system control group' and 'system control ID No.' in user mode (under 'system administrator info').

- 4) Turn off and then on the machine.

5 Installing the NE Controller-A1

Keep the following in mind when installing the controller to its host machine:

1. Be sure that the work complies with the laws and regulations of the country of installation.
2. Be sure that its host machine has properly been installed before starting the work.
3. Be sure to disconnect its host machine's power plug before starting the work.
4. Be sure to identify the screws by type (length, diameter) and location.
5. Be sure to prepare the appropriate settings data on a PC at the service station.

- 1) Remove the 2 screws [2], and detach the upper cover [1].

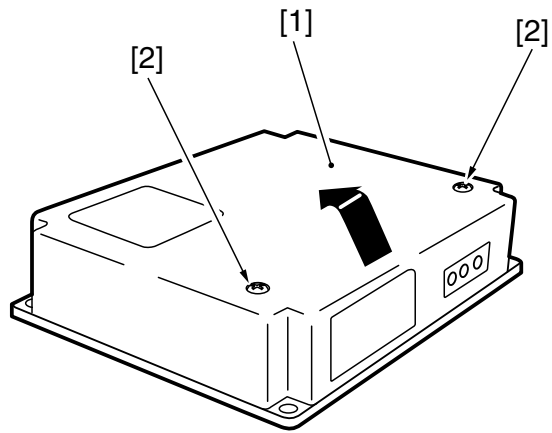

F04-500-01

- 2) Connect the connector [3] of the power supply unit to the connector [4] as shown.

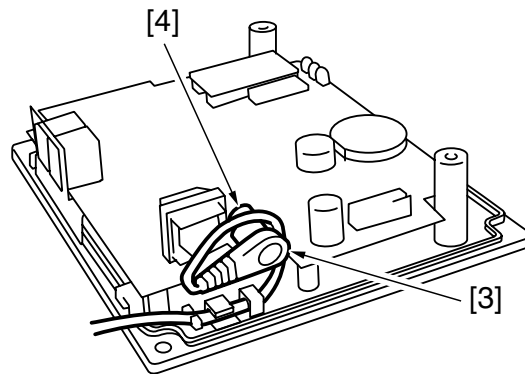

F04-500-02

- 3) Remove the 6 screws [5], and detach the face plate [3] of the host machine's upper rear cover.

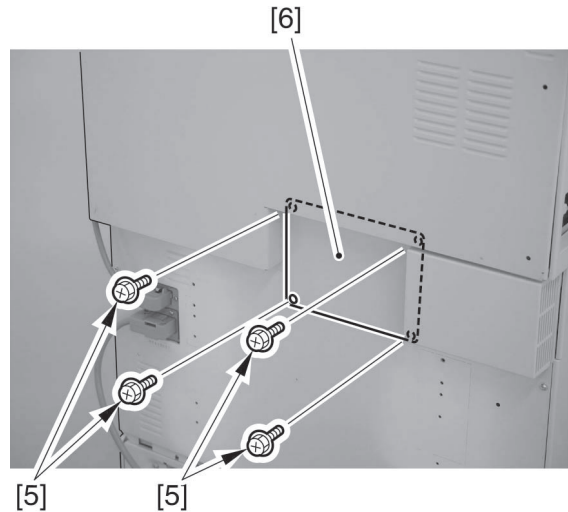

F04-500-03

- 4) Connect the cable [7] to the connector (J1511) [8] of the host machine's power distribution PCB.

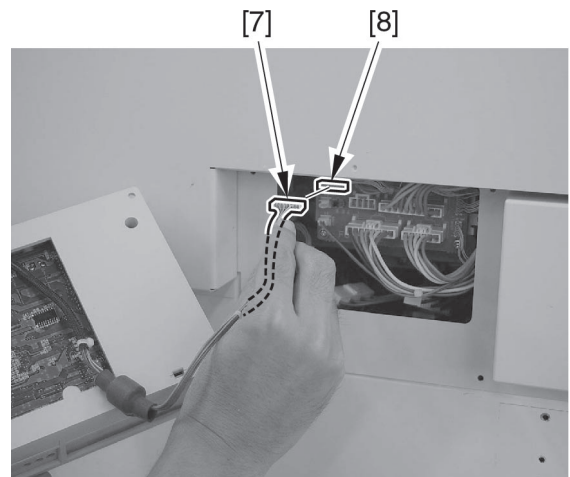

F04-500-04

- 5) Secure the controller to the host machine's rear cover using the 4 included screws.

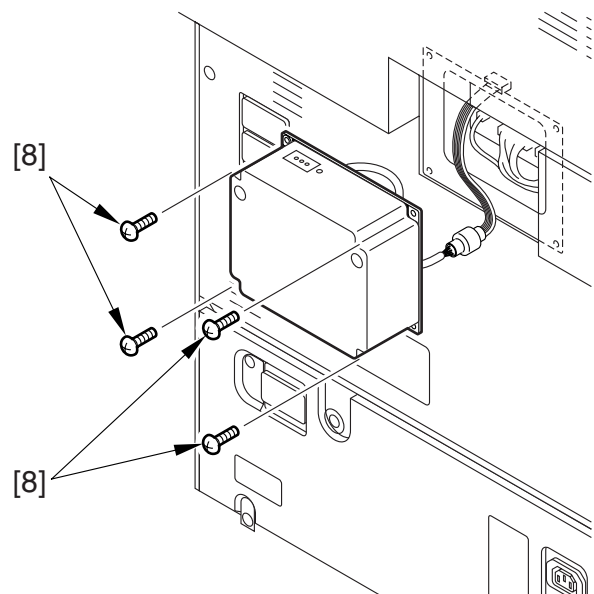

F04-500-05

- 6) Remove the slack from the cable connecting to the host machine; as necessary, bundle any stray segment of the cables as shown and secure it in place with a harness band [9].

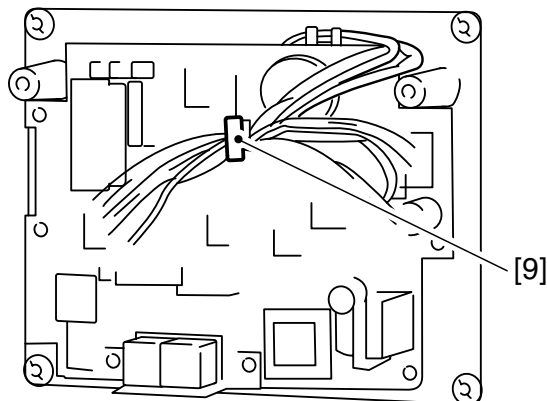

F04-500-06

- 7) Shift bit 4 of the DIP switch (SW2) [10] on the PCB to ON (so that the mode used to communicate with the host machine will be IPC).

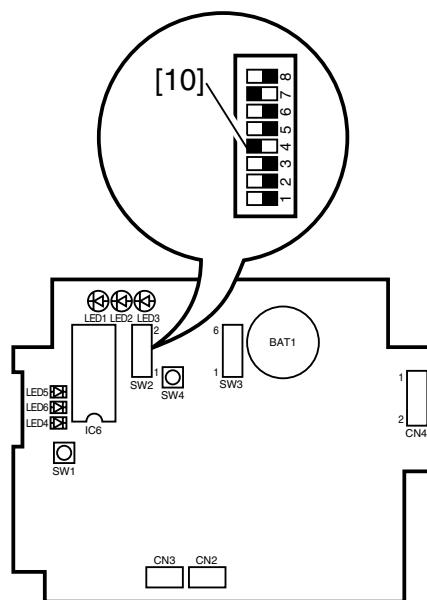

F04-500-07

- 8) If IC6 [11] is found on the PCB, shift bit 7 of the DIP switch (SW2) [12] to ON; otherwise, shift bit 7 of the DIP switch (SW2) [16] to OFF.



If IC6 [11] is not found, you need not mount it newly. If you must mount or replace a ROM (IC6) [11] for upgrading the controller, be sure to shift bit 7 of the DIP switch (SW2) [12] to ON.

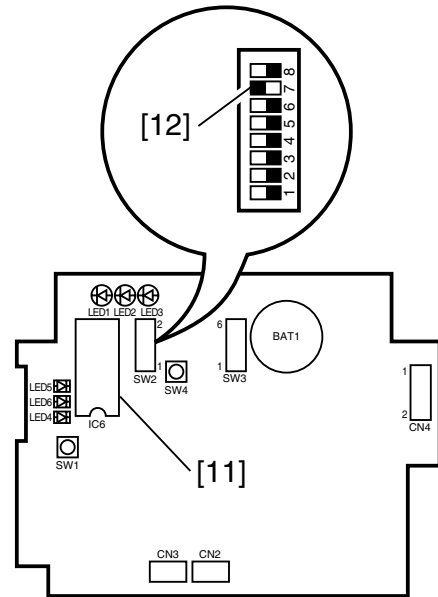

F04-500-08

- 9) Set the bits of the DIP switch (SW3) [13] as indicated.

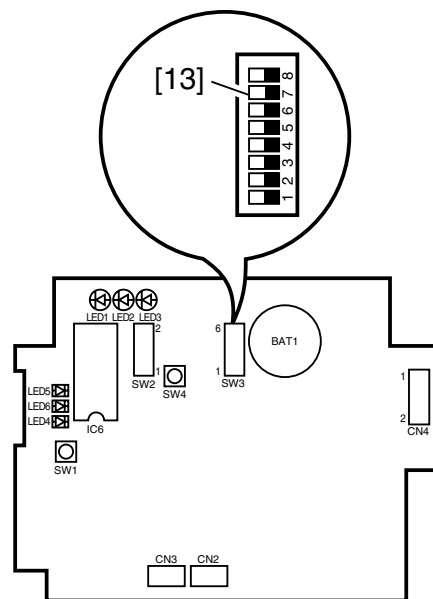

F04-500-09

Notation	Setting	Description		
		SW3-1	SW3-2	Description
SW3-1	See right	OFF	OFF	sets the signal transmission level of the modem to -16 dBm.
SW3-2		ON	OFF	sets the signal transmission level of the modem to -14 dBm.
		OFF	ON	sets the signal transmission level of the modem to -12 dBm.
		ON	ON	sets the signal transmission level of the modem to -10 dBm.
SW3-3	OFF	sets it to OFF at all times.		
SW3-4	ON	sets the line setting to tone pulse.		
	OFF	sets the line setting to dial pulse.		
SW3-5	ON	sets the dial pulse speed to 20 pps.		
	OFF	sets the dial pulse speed to 10 pps.		
SW3-6	–	not used		

T04-500-01

10) Connect the power plug of the power supply unit, and check to make sure that LED1 [14] (orange) on the PCB goes ON.

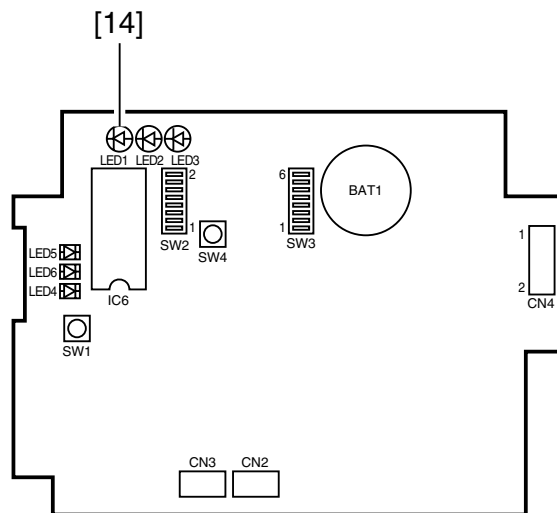

F04-500-10

11) Initialize the RAM. Set the bits of the DIP switch (SW2) [15] on the PCB as indicated in the table; then, press the push switch (SW4) [16] so that LED5 [17] (red) goes ON.

SW2 bits	Setting
SW2-1	OFF
SW2-2	OFF
SW2-3	ON
SW2-4	ON
SW2-5	OFF
SW2-6	OFF
SW2-7	See step 8).
SW2-8	OFF

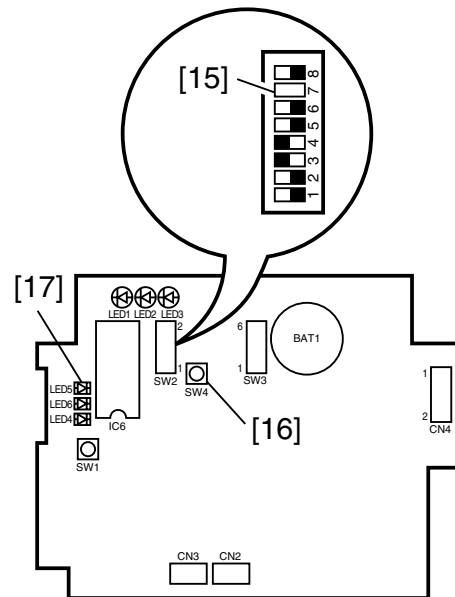

F04-500-11

12) When LED5 [17] (red) has gone ON, set the bits of the DIP switch (SW2) [15] on the PCB as indicated in the table, and press the push switch (SW4) [16] so that LED5 [17] (red) goes OFF, indicating the end of RAM initialization.

SW2 bits	Setting
SW2-1	OFF
SW2-2	OFF
SW2-3	OFF
SW2-4	ON
SW2-5	OFF
SW2-6	ON
SW2-7	See step 8).
SW2-8	OFF

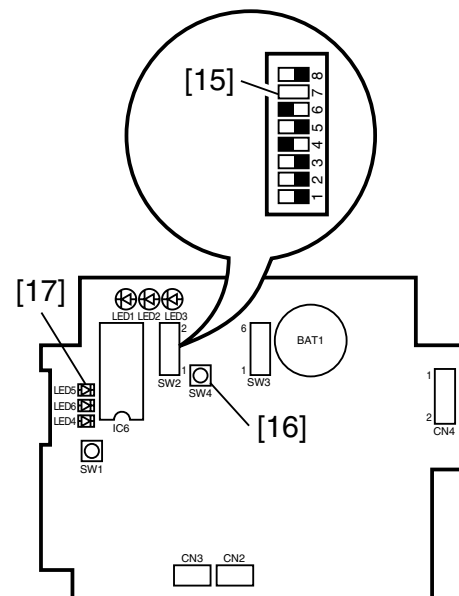

F04-500-12

- 13) Shift bit 6 of the DIP switch (SW2) [18] on the PCB to OFF.

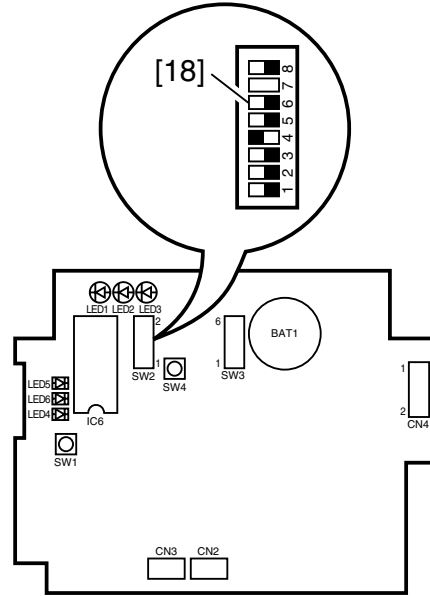

F04-500-13

- 14) Connect the telephone line to the controller. If the connection is to the controller alone, connect the modular jack cable to the connector (LINE) [19]. If the controller's extension function is to be used, connect the existing telephone or fax to the connector (TEL) [20] and then connect the telephone line to the connector (LINE) [19].

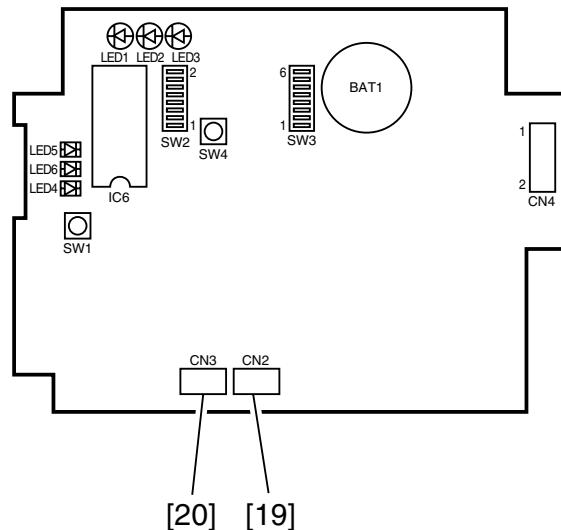

F04-500-14

- 15) Ring the service station for initial settings of the controller. (Upon arrival, LED 4 [21] (red) will start to flash.)

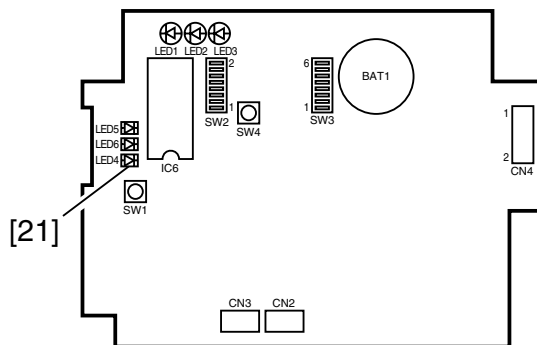

F04-500-15

- 16) Ring the service station, and find out if initial settings have been made. If the setup has failed, initialize the RAM once again (steps 11) through 13)) to start over.



Be sure to check with the service station once again to make sure that the controller settings are correct.

- 17) Check to make sure that the controller may be used to call up the PC at the service station. Press the push switch (SW4) [16] on the PCB so that LED6 [22] (red) goes ON. The LED goes OFF when the transmission ends successfully; otherwise, it will start to flash. When the push switch (SW4) [16] is pressed while LED6 [22] is flashing, a transmission will be initiated once again. If the push switch (SW1) [23] is pressed while LED6 [22] is flashing, the ongoing transmission will be cancelled.

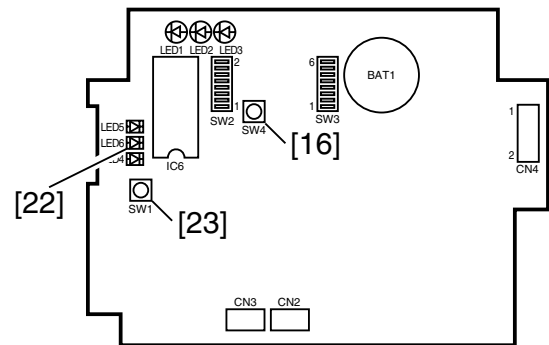

F04-500-16

- 18) Check to make sure that the communication with its host machine is normal. Connect the host machine's power plug, and turn on the power switch; then, check to make sure that LED2 [24] (orange) starts to flash.

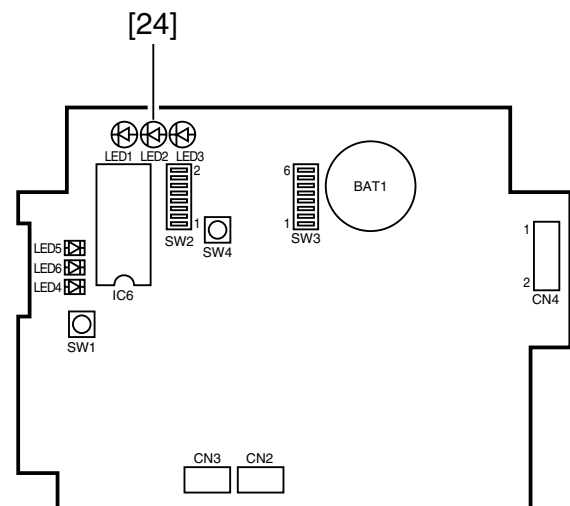

F04-500-17

- 19) Press the host machine's Start key, and check that LED3 [25] (pink) flashes each time paper is delivered.

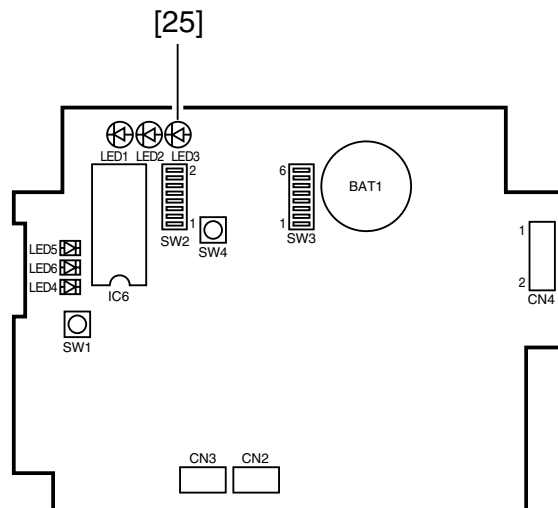

F04-500-18

- 20) Attach the switch settings label [26] on the top cover, and record the switch settings.
- 21) Secure the upper cover [1] using 2 screws [2]. When doing so, check to make sure that the power unit cable is secured to the cable guide inside the controller and is not trapped by the upper cover [1].

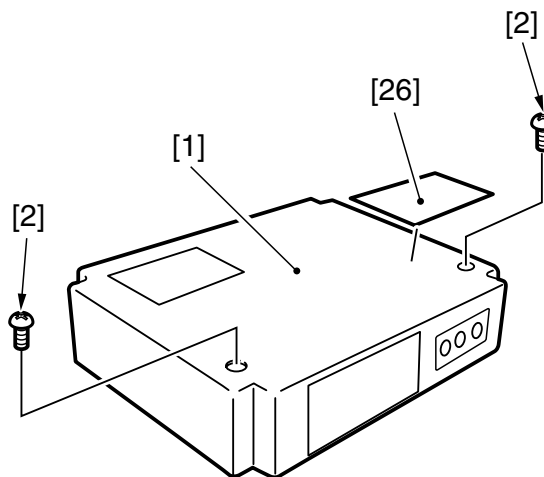

F04-500-19

6 Installing the Original Tray

6.1 Checking the Contents

Open the shipping box, and check to make sure that none of the following is missing:

- [1] Original base 1 pc.
- [2] Washer 2 pc.
- [3] Stepped screw (M4) 2 pc.

6.2 Installation Procedure

- 1) Fit the 2 included washers [1] and 2 stepped screws [2] to the upper right cover.

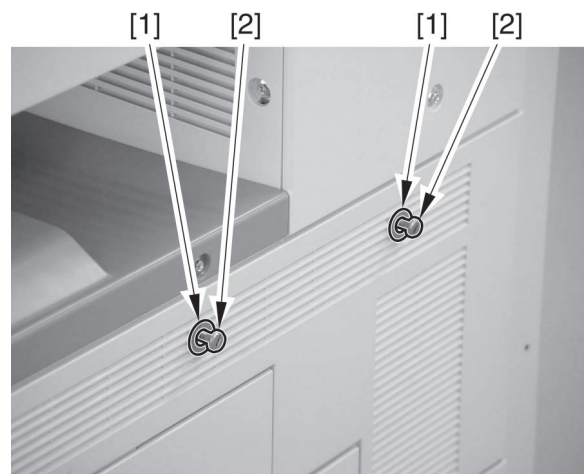

F04-602-01

- 2) Separate the original tray into top and lower parts, and hook the cut-off [2] of the reinforcing plate of the original tray (upper) [1] on the stepped screw [3] previously fitted.

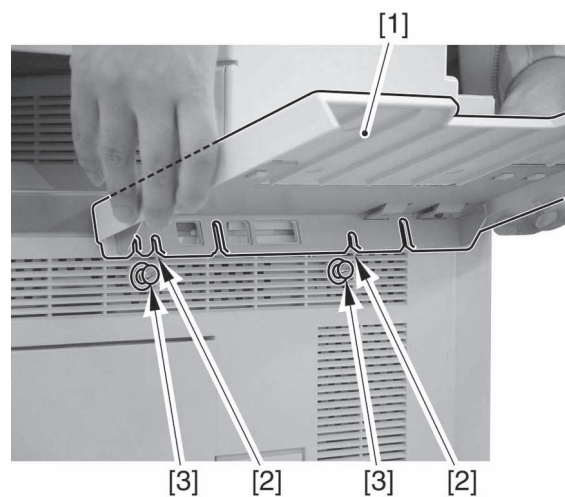

F04-602-02

- 3) Fit it to the original tray (lower) [1] together with the original tray (upper).

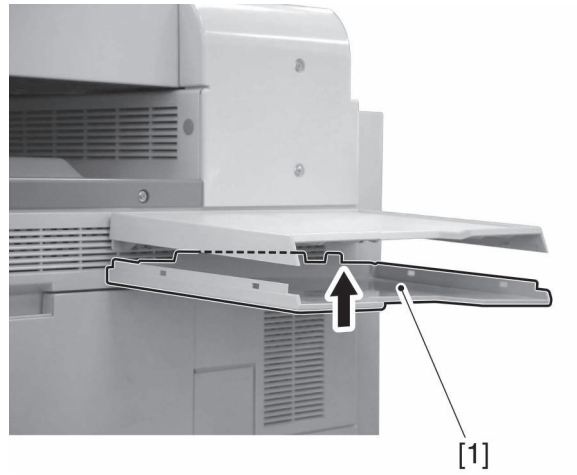

F04-602-03

7 Installing the Key Switch Unit-A1

7.1 Checking the Contents

Open the shipping box, and check to make sure that none of the following is missing:

- [1] Key switch unit 1 pc.
- [2] Control key 1 pc.
- [3] Binding screw (M4) 1 pc.

7.2 Installation Procedure

- 1) Remove the 2 screws [1], and detach the host machine's center delivery tray [2].

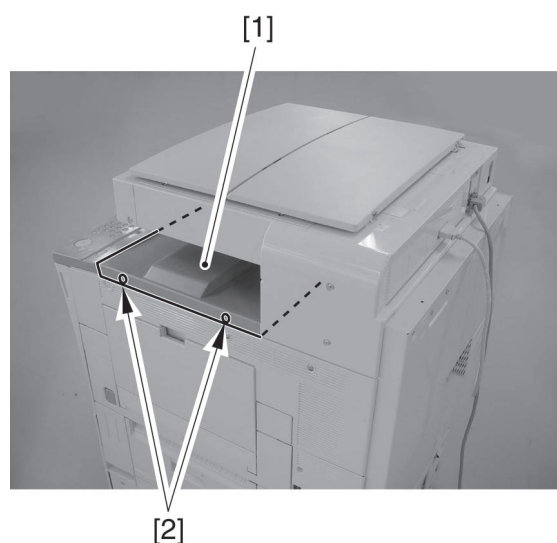

F04-702-01

- 2) Cut out the excess [1] of the upper right cover.

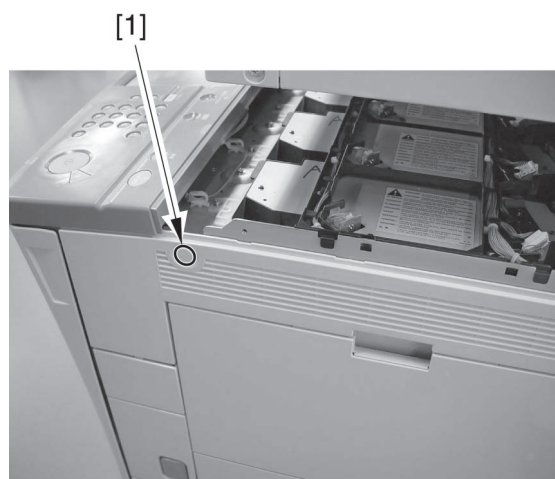

F04-702-02

- 3) Slide out the manual feed tray; then, remove the screw [1], and detach the middle right cover.

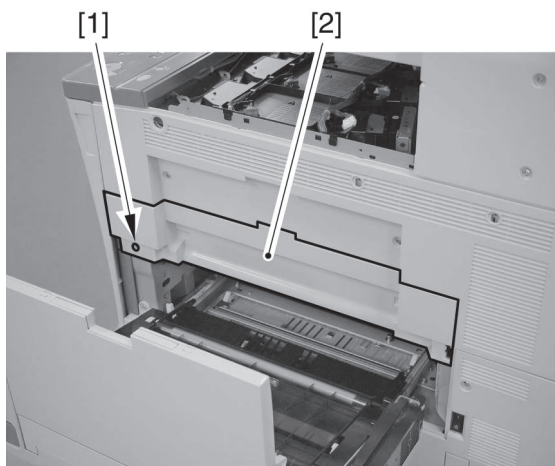

F04-702-03

- 4) Remove the 4 screws [1], and detach the upper right cover [2].

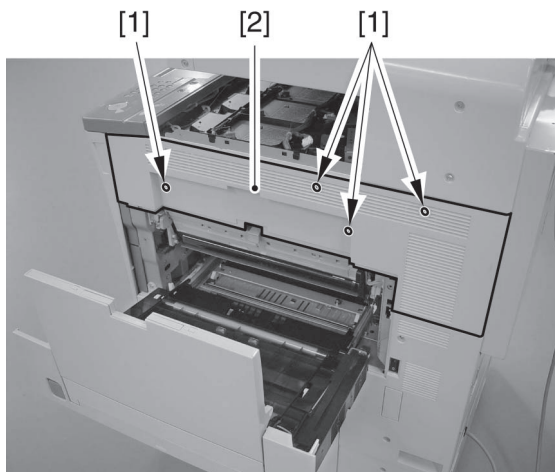

F04-702-04

- 5) Fit the plate of the key switch unit [1] into the cut-off of the upper right stay; then, secure it in place using the included binding screw [2].

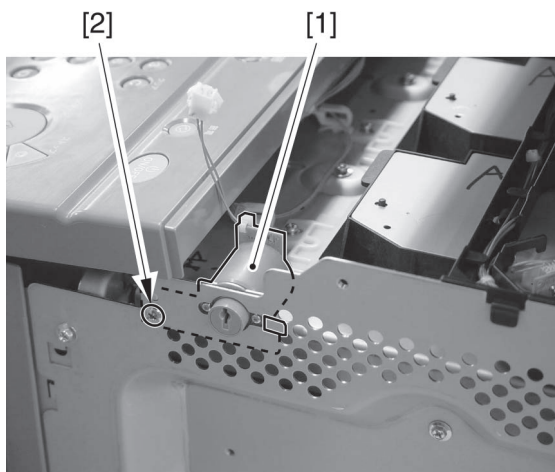

F04-702-05

- 6) Connect the connector [1].

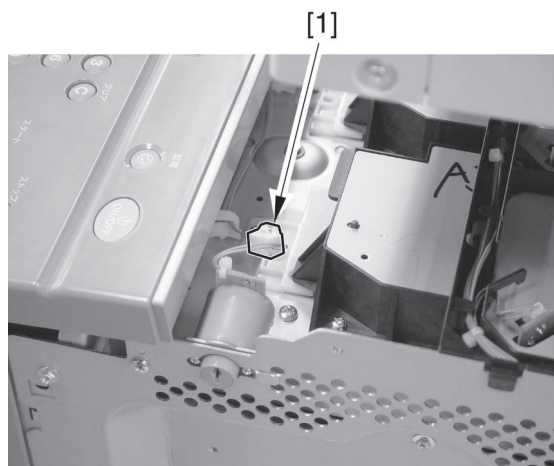

F04-702-06

- 7) Attach the upper right cover using the 2 previously removed screws.
- 8) Attach the printer upper right cover using the 2 right screws.

7.3 Making Checks After Installation

- 1) Start service mode.
- 2) Make the following selections in service mode, and enter '1':
COPIER>FUNCTION>INSTALL>KEY.
- 3) Turn on and then off the host machine.

8 Installing the Anti-Condensation Heater



Be sure to turn off the host machine before starting the work and observe the points to note indicated on the next page.

8.1 Checking the Contents

Open the shipping box, and check none of the following is missing:

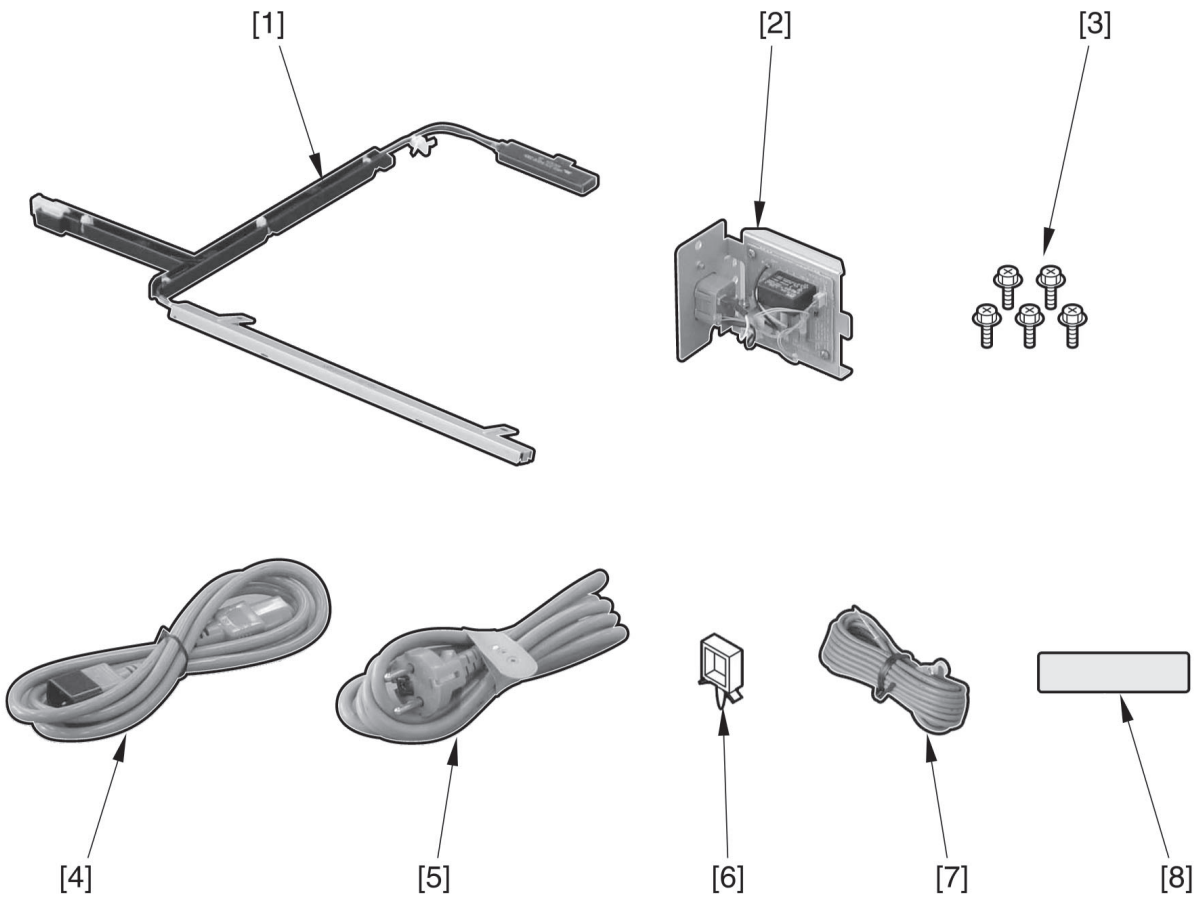

F04-801-01

[1] Anti-condensation heater	1 pc.	[6] Wire saddle	2 pc.
[2] Fuse PCB unit	1 pc.	[7] Grounding cord	
[3] RS tightening screw (M4×8)	5 pc.	(100V model only)	1 pc.
[4] Power cable (for wall outlet)	1 pc.	[8] Power supply label	
[5] Power cable (for copier outlet)	1 pc.	(100V model only)	1 pc.

8.2 Installation Procedure



Before starting the work, be sure to perform the following:

1. Turn off the control panel power switch.
2. Turn off the main power switch.
3. Disconnect the power cable (for wall outlet).

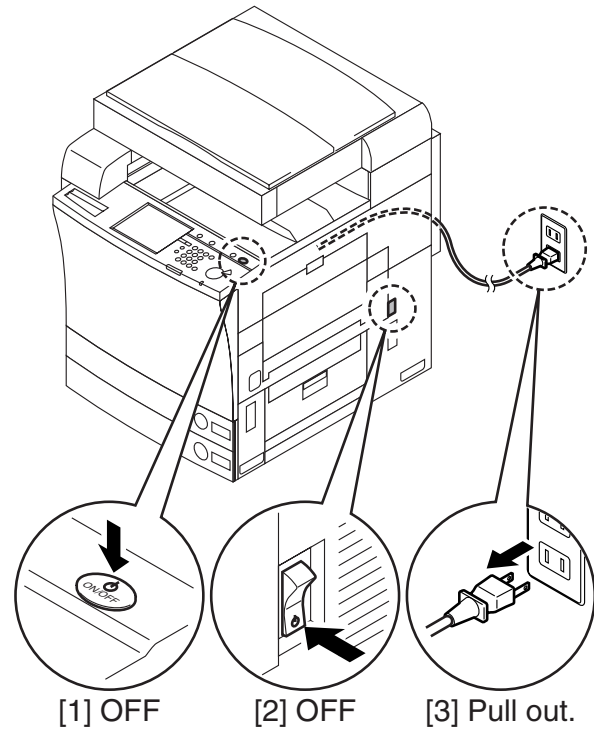

F04-802-01

- 1) Remove the copyboard cover. (If an ADF is used, you need not remove it.)
- 2) Release the 2 cable clamps [1] to free the reader power cable.

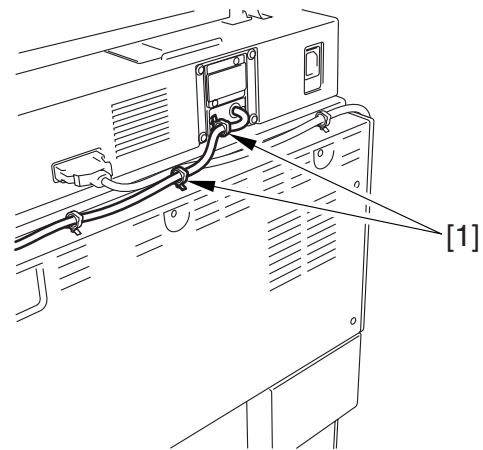

F04-802-02

- 3) Disconnect the reader controller communication cable.

- 4) Remove the 7 screws [1], and detach the reader unit rear cover [2]. (Save it for later.)

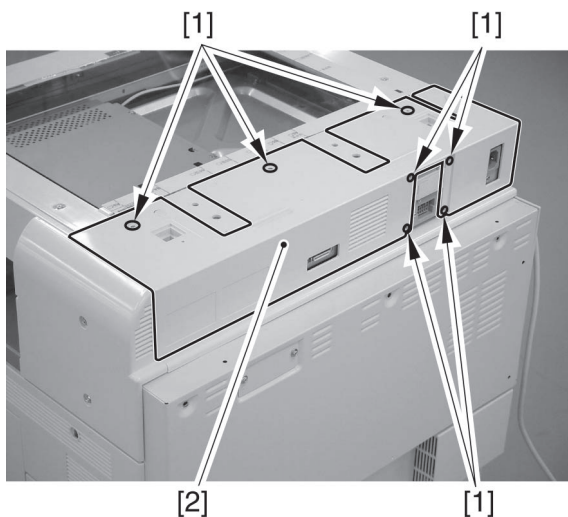

F04-802-03

- 5) Remove the 2 screws [1], and detach the face plate. (Save it for later.)

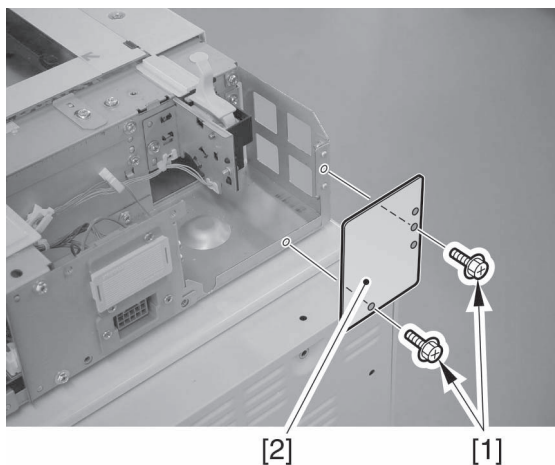

F04-802-04

- 6) Using the 2 included screws [1], mount the fuse PCB unit [2].

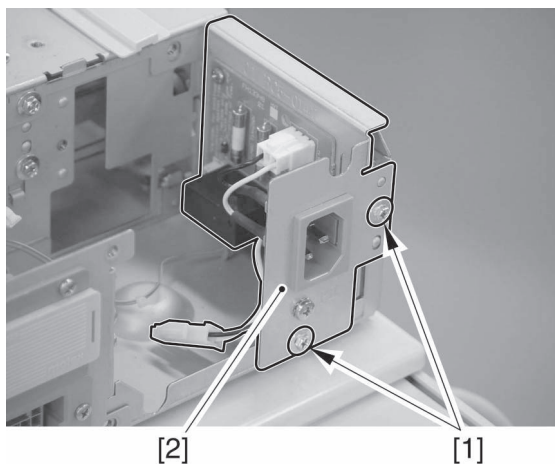

F04-802-05

- 7) Connect the harness [1] of the fuse PCB unit to the connector [2] of the interface PCB.

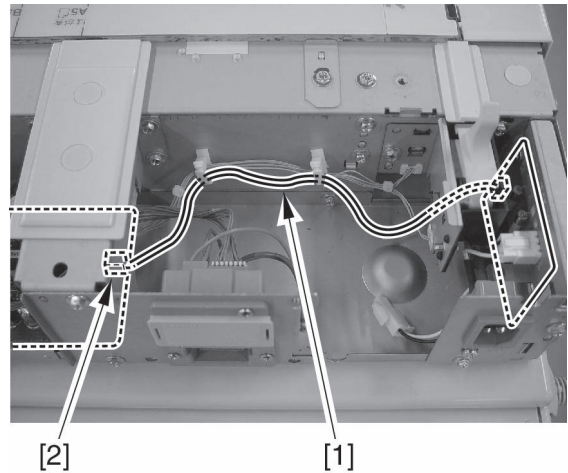

F04-802-06

8)



When removing the copyboard glass, take care not to touch the glass face and the white plate found on the back of it. (Dirt can cause black lines in the images.)
If soiled, clean it with lint-free paper moistened with alcohol.

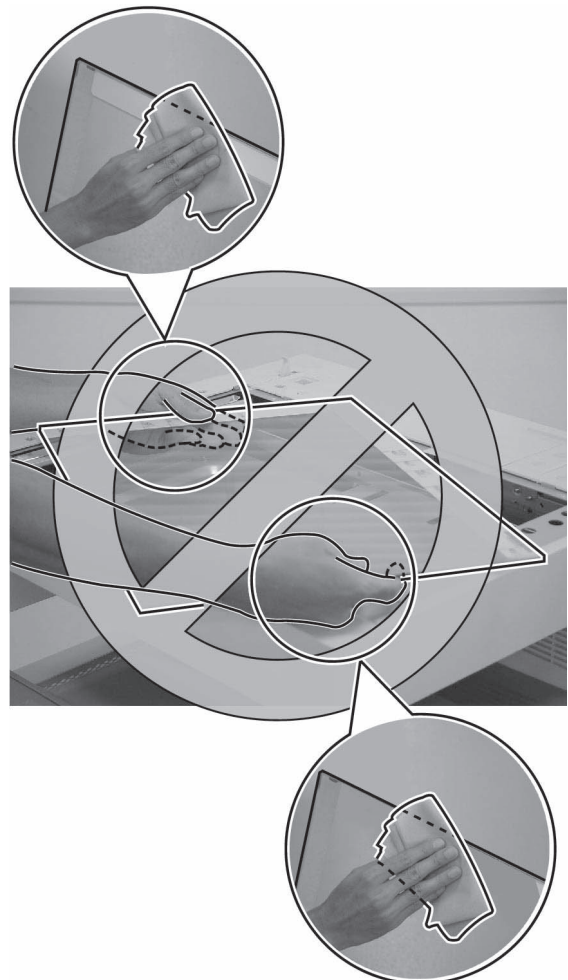

F04-802-07

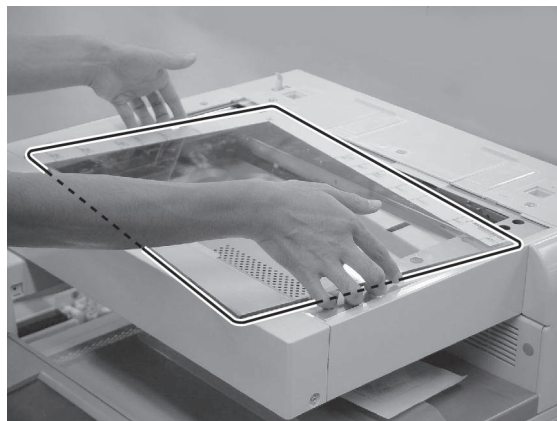

F04-802-08

Remove the 2 screws [1], and detach the right glass retainer [2]; then, detach the copyboard glass [3].

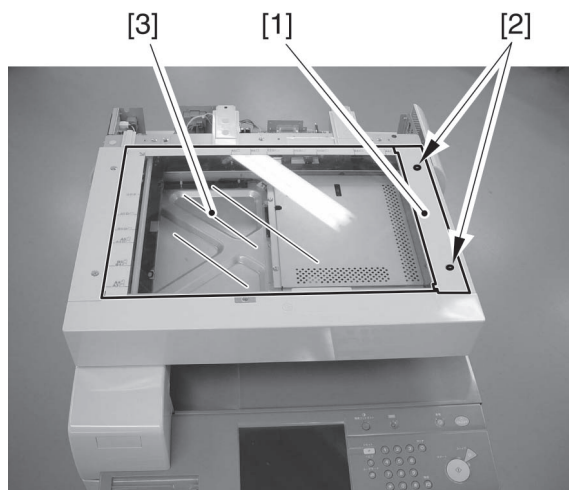

F04-802-09

9)



When moving the No. 1 mirror base, be sure to hold it by the bend [A] of the cut-out in the mirror stay shown in the figure.

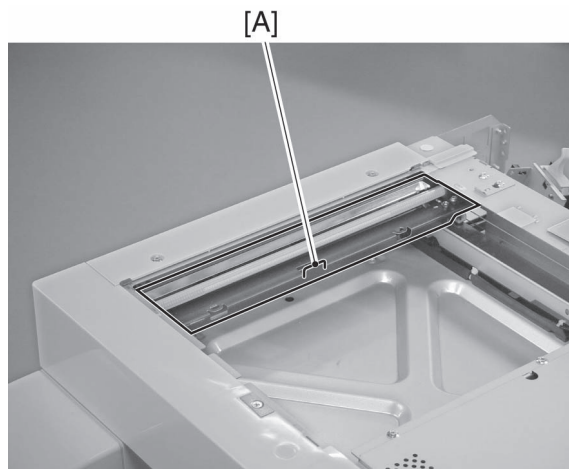

F04-802-10

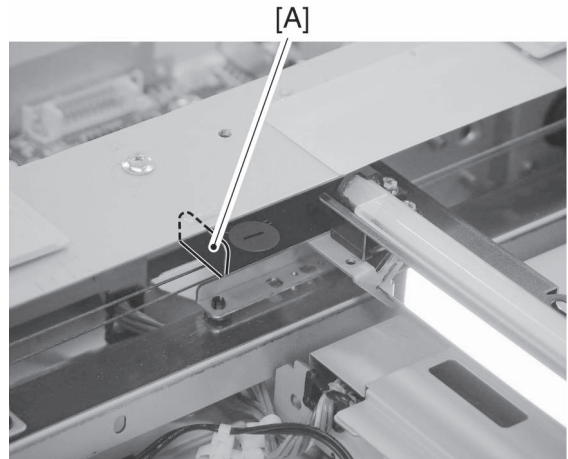

F04-802-11

Move the No. 1 mirror base [1] fully to the right.

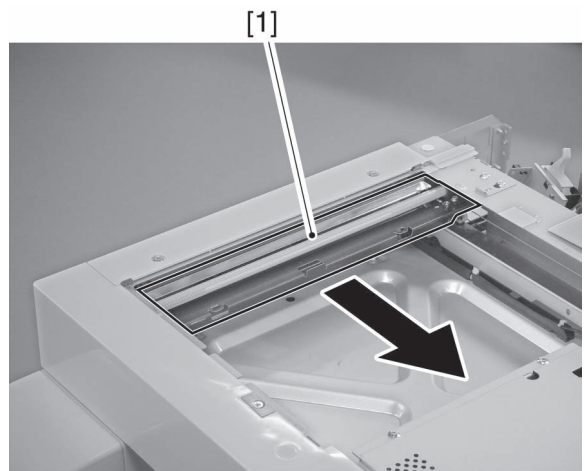

F04-802-12



When shifting the mirror unit, be sure not to touch the mirror unit. Otherwise, clean it with lint-free paper moistened with alcohol.

10) Mount the anti-condensation heater where indicated in the figure. When doing so, be sure that the harness guide of the heater is above the harness of the fuse PCB.

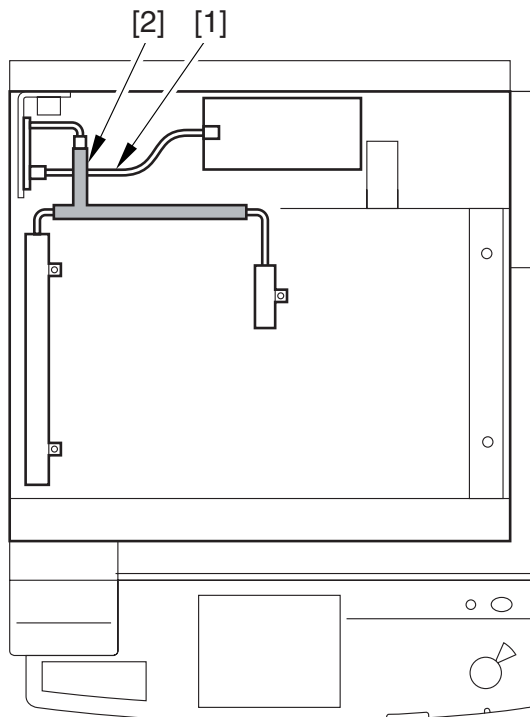

F04-802-13

11) Using 2 included screws [1], secure the longer segment (silver-colored) of the anti-condensation heater [2].

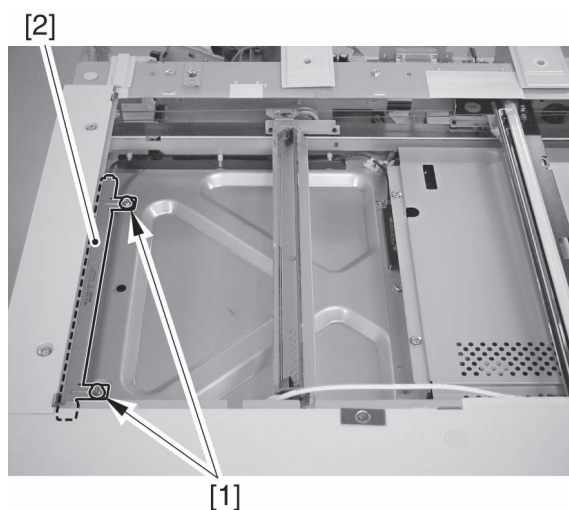

F04-802-14

- 12) Holding it where indicated [A], shift the No. 1 mirror base to the left.

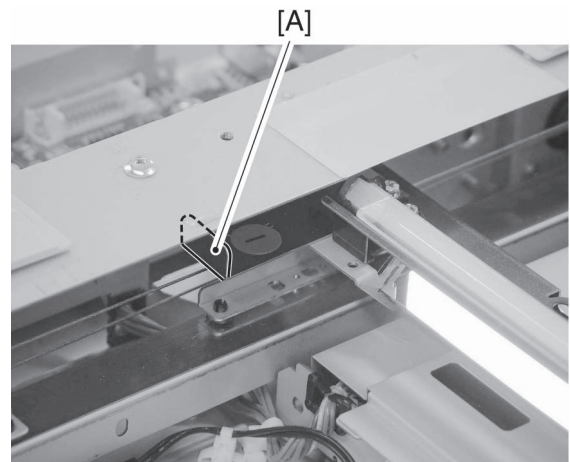

F04-802-15

- 13) Fit the harness guide [1], i.e., fit it in the hole in the base plate, and shift it to the right to secure; then, fit the harness band [2].

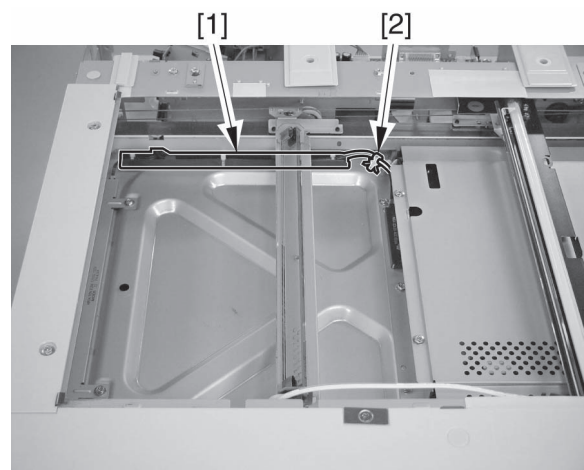

F04-802-16

- 14) Secure the shorter segment (black) of the anti-condensation heater [1] using 2 included screws [2]. (To do so, insert a screwdriver through the hole in the lens cover.)

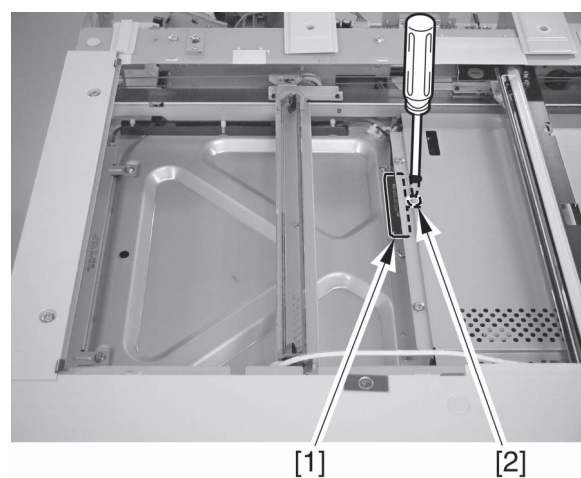

F04-802-17

- 15) Connect the connector [1] of the anti-condensation heater to the connector [2] of the fuse PCB unit.

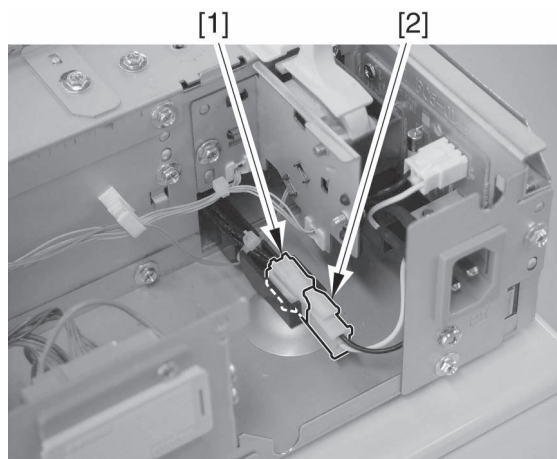

F04-802-18

- 16) Put the No. 1 mirror base to its initial position (left edge).
17) Attach the reader unit rear cover.
18)



When removing the copyboard glass, be sure not to touch the glass face or the white plate found on its back. (Dirt can cause black lines in the images.) If soiled, clean it with lint-free paper moistened with alcohol.

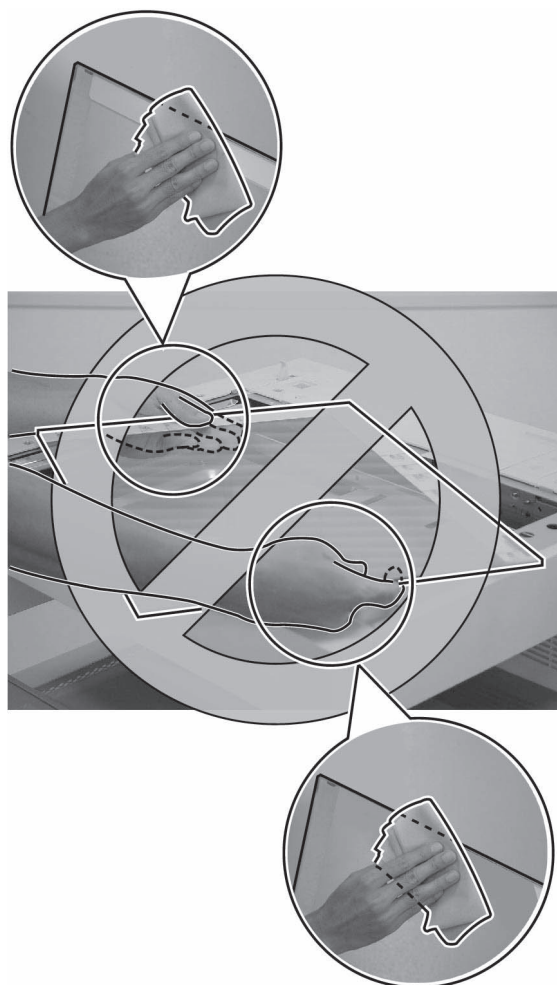

F04-802-19

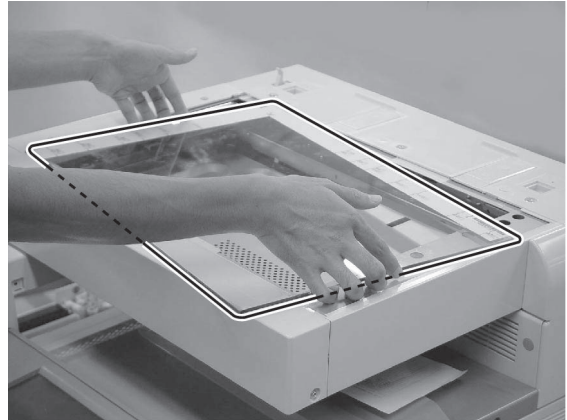

F04-802-20

Attach the copyboard glass.

- 19) Secure the reader controller communication cable and the reader power supply cable back to their initial positions.
- 20) Connect the power cable.
 - If a pedestal (2-cassette pedestal or plain pedestal) is connected to the host machine, remove the 2 face stickers [1] from the upper rear cover.

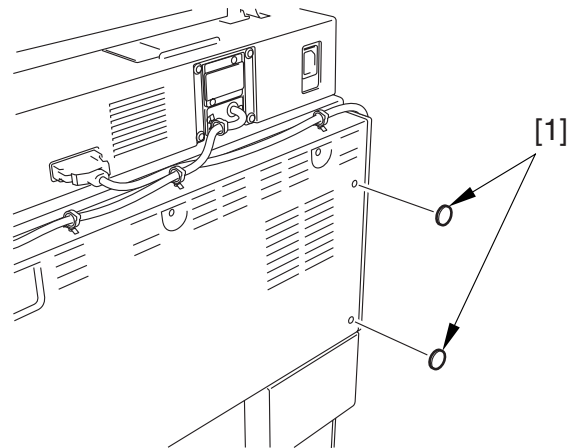

F04-802-21

Connect the power cable (for wall outlet) [1] and the inlet terminal and the outlet terminal (topmost of the 3) of the pedestal; then, secure it in place using the 2 included wire saddles.

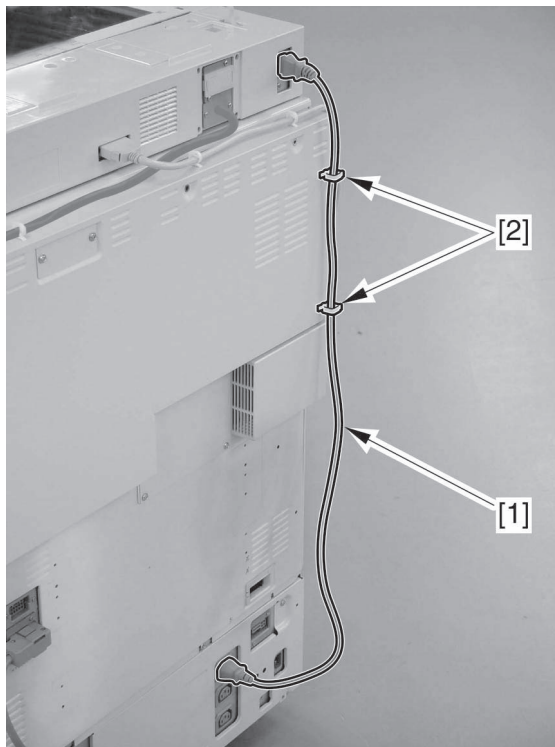

F04-802-22

- If no pedestal (2-cassette pedestal or plain pedestal) is connected to the host machine, connect the power cable (for wall outlet) [1] to the inlet terminal.

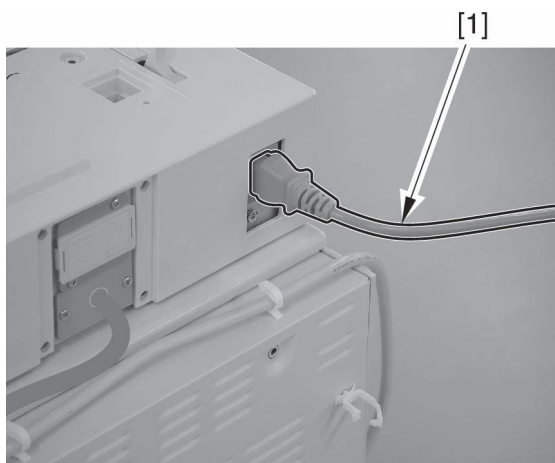

F04-802-23

- Only if 100V Model

21) Remove the screw [1] found under the inlet terminal, and connect the included grounding wire [1] (i.e., if no pedestal is connected).

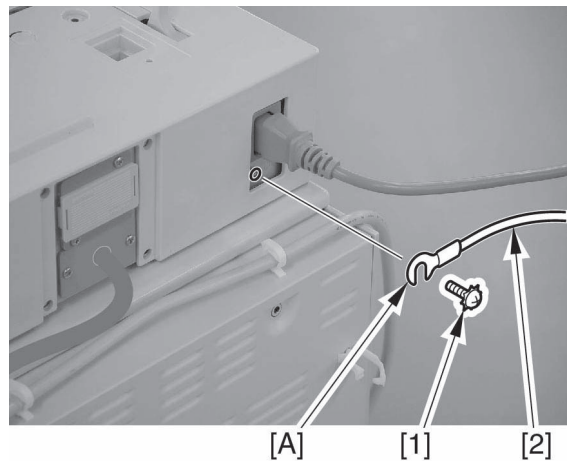

F04-802-24

22) Attach the included power supply label [1] to the reader unit rear cover.

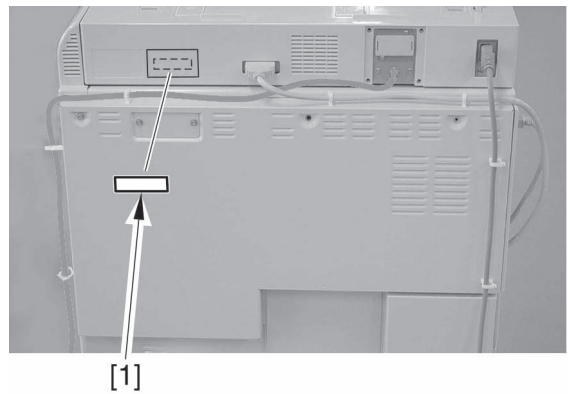

F04-802-25

9 Installing the Cassette Heater Kit-A1

To install the heater kit, you must obtain a separately available Cassette Heater Unit-24.



Before starting the work, be sure to turn off the host machine; for installation, keep in mind the points to note indicated on the next page.

9.1 Checking the Contents

Open the shipping box, and check to make sure that none of the following is missing:

Cassette Heater Kit-A1

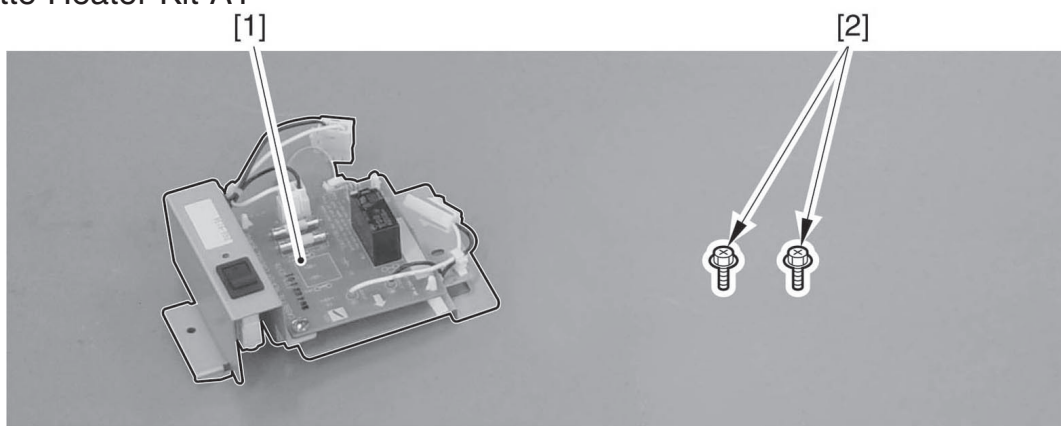

F04-901-01

[1] Heater PCB unit 1 pc. [2] RS tightening screw (M4) 2 pc.

Cassette Heater Unit-24

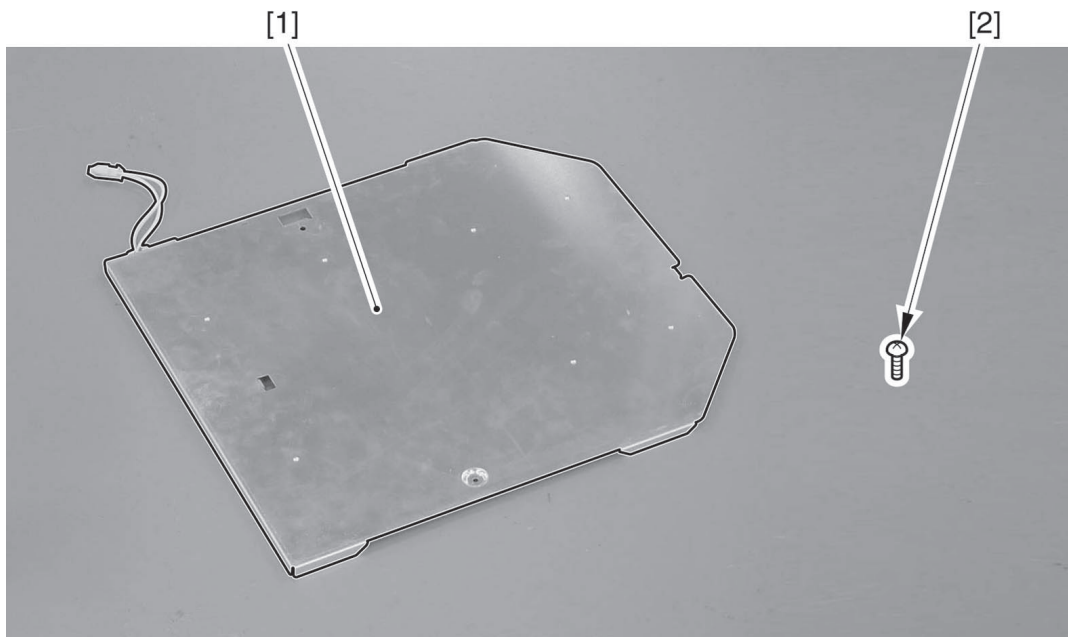

F04-901-02

- [1] Heater unit 1 pc. [2] Binding screw (M4) 1 pc.

9.2 Installation Procedure



Before starting the work, be sure to perform the following on the host machine in the order indicated:

1. Turn off the control panel power switch.
2. Turn off the main power switch.
3. Disconnect the power cable (for power outlet).

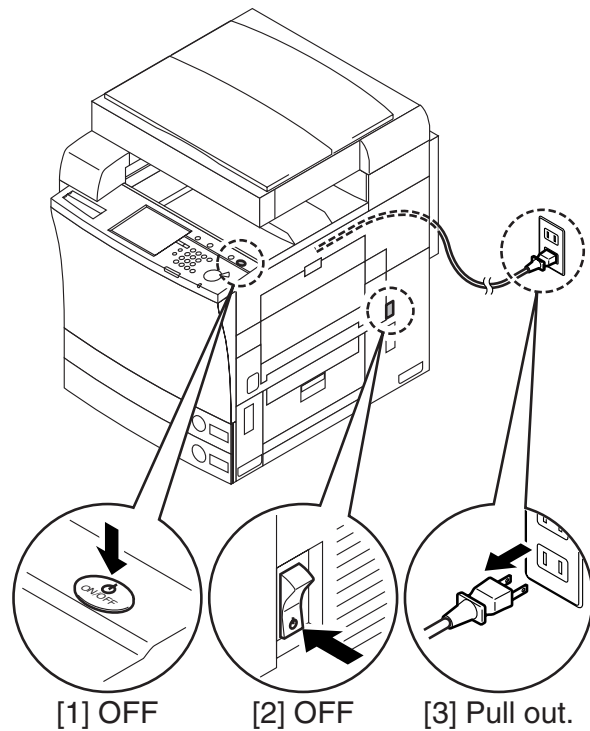

F04-902-01



Memo

The Cassette Heater Kit-A1 is designed for installation to either a copying machine or a 2-cassette pedestal using the same installation procedure.

The following steps (images) are based on installation to a 2-cassette pedestal.

9.2.1 Installing the Cassette Heater Kit to a Copier

- 1) Pull out both cases of the copier.
- 2) Insert a screwdriver from the front of the copier, and remove the 2 screws [2] to detach the heater PCB unit cover [1] attached to the rear side plate of the copier.

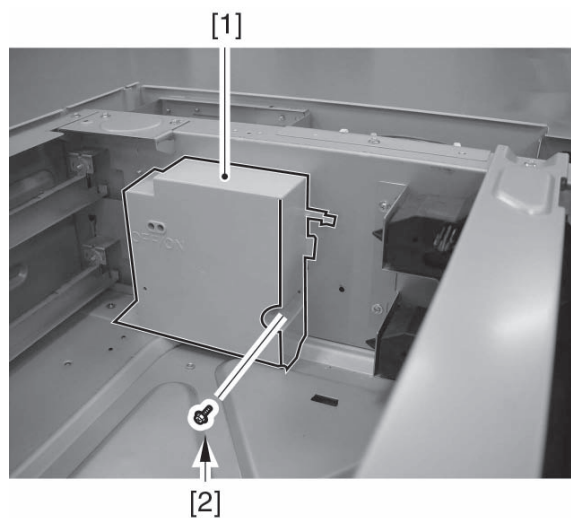

F04-902-02

3)



When detaching the heater unit PCB cover, slide it upward while pulling the stop [1] mounted to the cover toward the front.

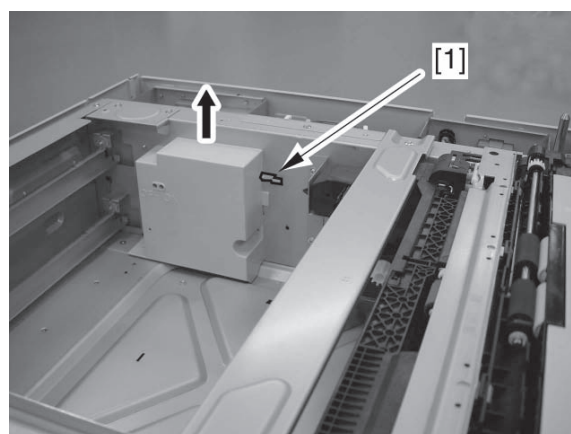

F04-902-03

4)



Before installing the heater PCB unit, be sure to turn off the host machine.

Using the 2 included RS tightening screws [1], mount the heater PCB unit [2], and connect the 2 connectors [3].

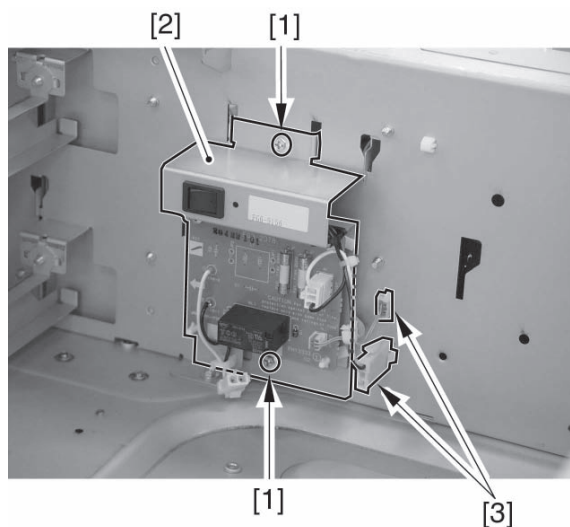

F04-902-04

5) Connect the included connector of the heater unit with the connector [2] of the heater PCB unit.

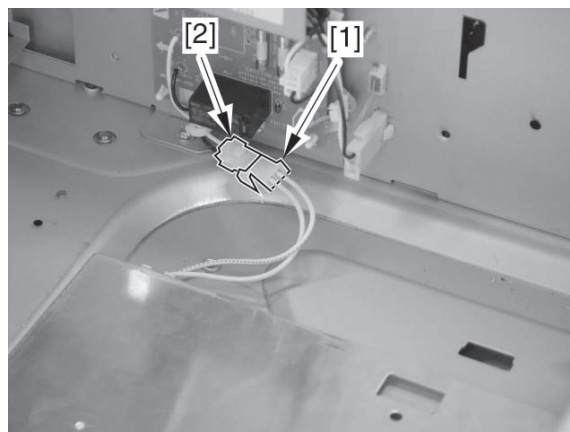

F04-902-05

6)



When mounting the heater unit, be sure to securely fit the 3 protrusions, and check to make sure there is no gap.

Fit the 3 protrusions [2] of the heater unit [1] into the slits in the base plate; match the holes, and secure it to the cassette heater unit using the included binding screw [3].

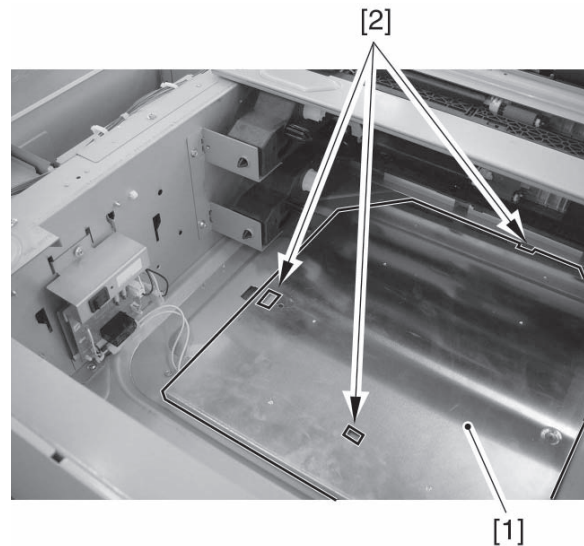

F04-902-06

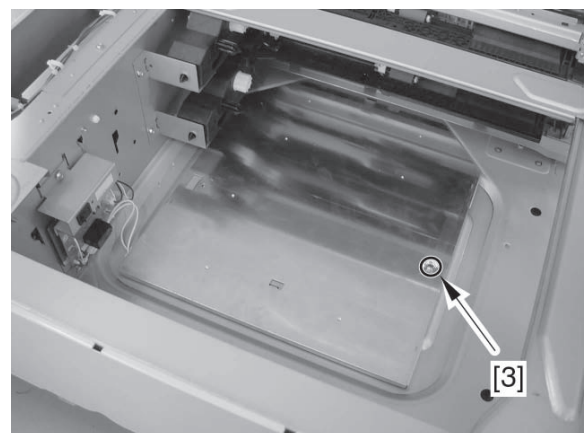

F04-902-07

7) Mount the heater PCB unit cover using the previously removed screw.

9.2.2 Installing the Cassette Heater Kit to a 2-Cassette Pedestal-X1

- 1) Slide out both cassettes from the cassette pedestal.

Hereafter, go through the same steps used for the installation to a copier.

10 Replacing the Drum Unit

10.1 Preparing for the Work

- 1) Take out the drum unit (Y) from its shipping box; then, take out the drum unit (Y) [1] from its packing bag, and also take out the drying agent [2].

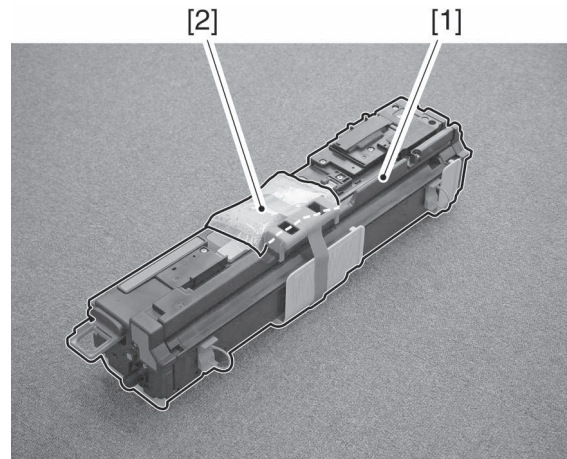

F04-1001-01

2)



Do not remove the protective cover. It serves as a rail for installation.

Pull out the releasing hook [1] at the front and the rear.

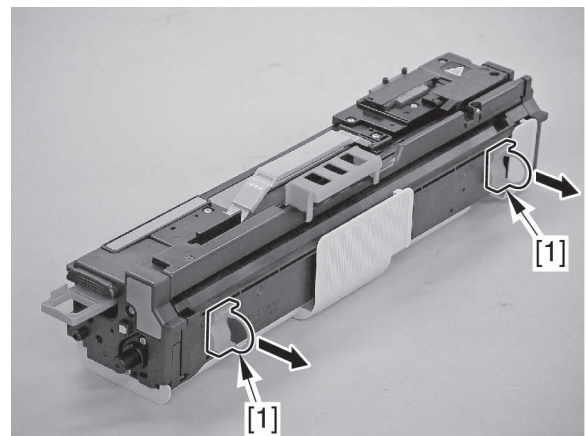

F04-1001-02

- 3) Remove the interference protective sheet [1].

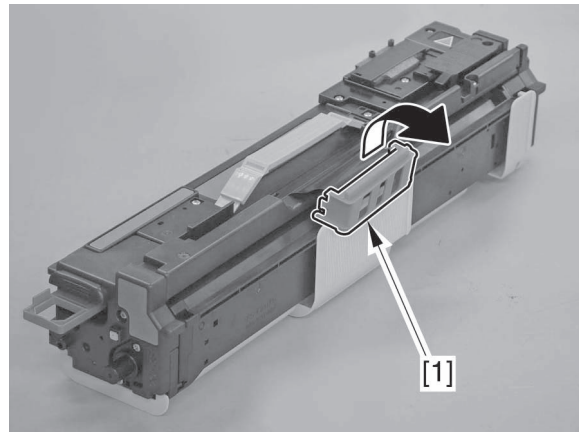

F04-1001-03

10.2 Installation Procedure

Before starting the work, be sure to perform the following on the host machine in the order indicated:

1. Turn off the control panel power switch.
2. Turn off the main power switch.
3. Pull out the power cable (for wall outlet).

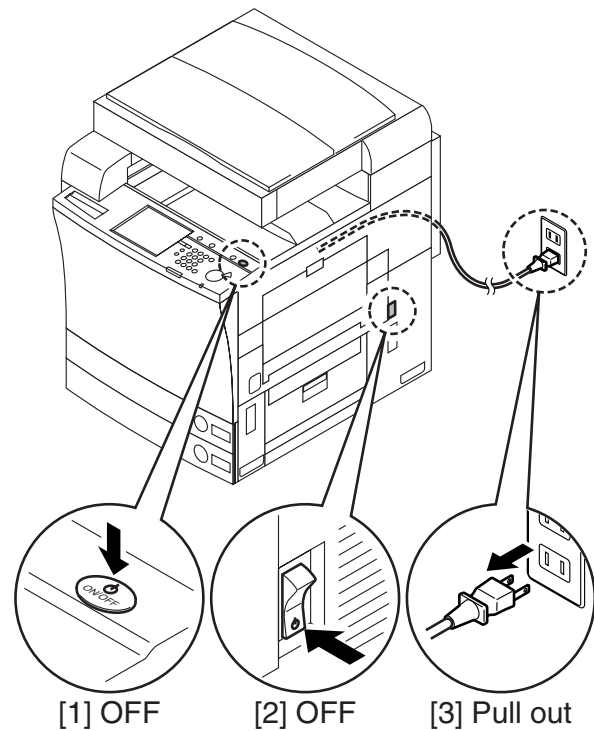

F04-1002-01

- 1) Open the copier's front cover, and turn the intermediate transfer unit releasing lever [1] in the direction of the arrow.

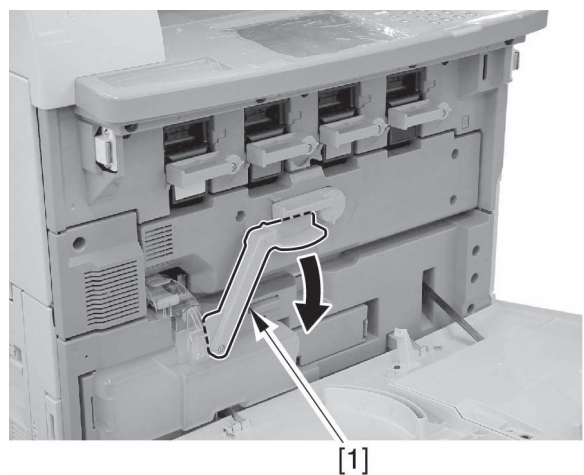

F04-1002-02

- 2) Turn the open/closed lever of the drum unit cover [1] counterclockwise by 90° to open the drum unit cover.

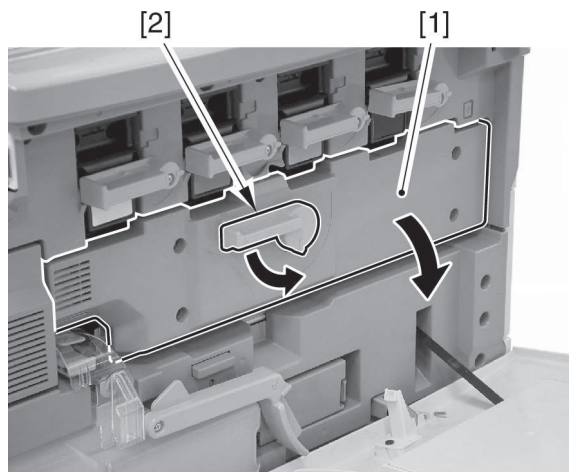

F04-1002-03

- 3) Match the dent [1] found in the back of the drum unit cover and the protrusion [2] on the bottom face of the protective cover, and secure it in place.

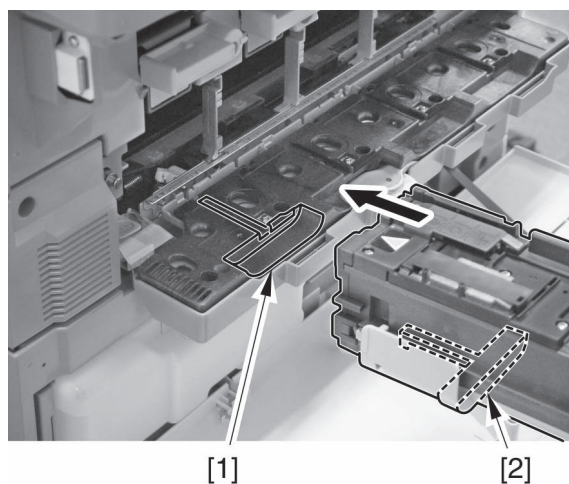

F04-1002-04

4)



1. Push it in the direction of the arrow [1] indicated on the top edge of the drum unit.
2. After setting the drum unit in place, be sure to store away the protective cover.

Holding the protective cover [2] level, push in the drum unit (Y) [3] to set; the units are Y, M, C, and Bk, starting from the left.

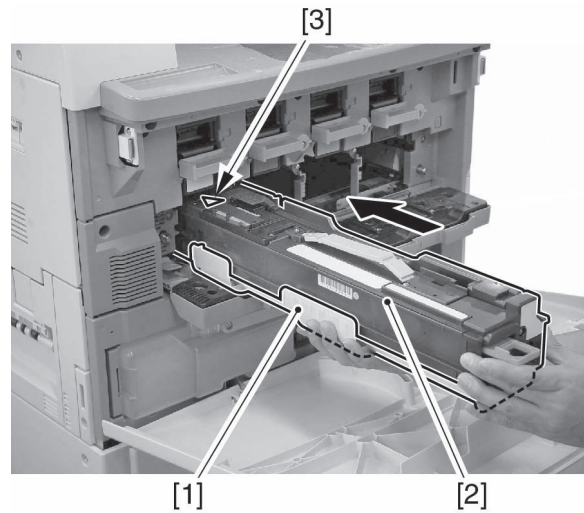

F04-1002-05

5)



When pulling out the sealing tape, be sure to hold the drum unit in place so that the drum unit will not slide out.

Pull out the sealing tape [1].

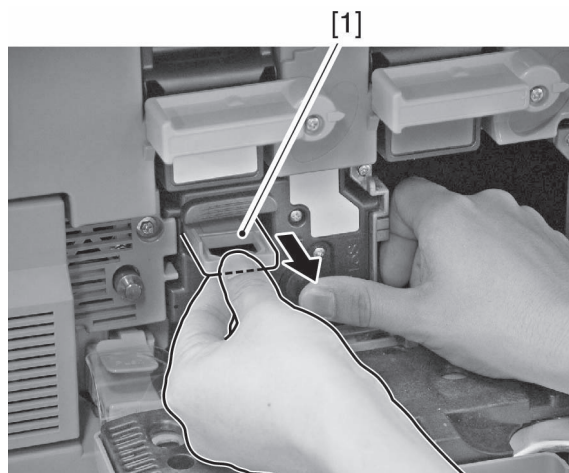

F04-1002-06

- 6) Set the drum units for other colors (M, C, Bk) in the same way.
- 7) Close the drum unit cover, and shift the open/close lever back to its initial position.
- 8) Shift the intermediate transfer unit releasing lever back to its initial position.
- 9) Close the front cover.

Reader Unit

SERVICE MANUAL

Contents

CHAPTER 1 EXPOSURE

1 Outline of Operation	1-1	2.4.3 Outline of Detection Operations	1-15
1.1 Specifications, Control Mechanisms, and Functions	1-1	3 Assembly and Disassembly	1-17
1.2 Major Components	1-2	3.1 Removing the Copyboard Glass	1-17
1.3 Construction of the Control System	1-4	3.1.1 After Replacing the Copyboard Glass	1-18
1.4 Reader Controller PCB	1-5	3.2 Removing the Interface PCB ...	1-19
1.5 Basic Sequence of Operations ...	1-6	3.3 Removing the Copyboard Cover Open/Closed Sensor	1-21
1.5.1 Basic Sequence of Operations at Power-On	1-6	3.4 Removing the Mirror Base Home Position Sensor	1-23
1.5.2 Basic Sequence of Operations in Response to a Press on the Start Key (book mode, 1 original)	1-7	3.5 Removing the Fuse PCB Unit (option; 100/230V model only)	1-24
2 Various Control Mechanisms	1-8	3.6 Removing the Anti-Condensa- tion Heater (option; 100/230V model only)	1-25
2.1 Controlling the Scanner Drive ...	1-8	3.7 Removing the Scanner Motor	1-27
2.1.1 Outline	1-8	3.7.1 Mounting the Scanner Motor	1-28
2.1.2 Controlling the Scanner Motor	1-9	3.7.2 Checking the Operation After Mounting the Scanner Motor	1-29
2.2 Changing the Reproduction Ratio	1-11	3.8 Removing the Scanning Lamp	1-30
2.2.1 Changing the Reproduction Ratio in Main Scanning Direction	1-11	3.9 Removing the Original Size Sensor	1-33
2.2.2 Changing the Reproduction Ratio in Sub Scanning Direction	1-11	3.10 Removing the CCD Unit	1-34
2.3 Turning On/Off the Scanning Lamp (LA1)	1-12	3.10.1 After Replacing the CCD Unit	1-34
2.3.1 Outline	1-12	3.11 Removing the Inverter PCB	1-35
2.3.2 Scanning Lamp	1-12	3.12 Removing the Reader Controller PCB	1-36
2.3.3 Turning On/Off the Lamp	1-12	3.12.1 When Replacing the Reader Controller PCB	1-37
2.3.4 Checking for an Error	1-13		
2.4 Identifying the Size of Originals	1-14		
2.4.1 Outline	1-14		
2.4.2 Points of Detection (original size)	1-14		

CHAPTER 2 IMAGE PROCESSING

1 Outline	2-1	2.4 A/D Conversion of CCD Output	2-3
1.1 Specifications, Control Mechanisms, and Functions	2-1	3 Digital Image Processing	2-4
1.2 Functional Construction of the PCBs	2-1	3.1 Outline	2-4
2 Analog Image Processing	2-2	3.2 Shading Correction	2-5
2.1 Outline	2-2	3.2.1 Outline	2-5
2.2 CCD Drive	2-3	3.2.2 Shading Adjustment	2-5
2.3 CCD Output Gain Correction and Offset Correction	2-3	3.2.3 Shading Correction	2-5

CHAPTER 3 EXTERNALS AND CONTROLS

1 Power Supply	3-1	1.2 Route of Power Supply	3-2
1.1 Timing of Power Supply	3-1		

CHAPTER 1

EXPOSURE

1 Outline of Operation

1.1 Specifications, Control Mechanisms, and Functions

The major specifications, control mechanisms, and functions of the original exposure system are as follows:

Item	Description
Scanning lamp	Xenon lamp
Original scanning	in book mode: by moving the scanner in ADF mode: by moving the scanner
Reading resolution	600 dpi (main scanning) × 600 dpi (sub scanning)
Scanner position detection	by scanner HP sensor (PS2)
Lens	lens array (single focus, fixed)
Enlargement/reduction (zoom)	in copyboard cover mode: 100% in ADF mode: 100% in main scanning direction, image processing in the controller unit in sub scanning direction, image processing in the controller unit
Scanner drive control	No. 1/No. 2 mirror mount (control by a pulse motor M1)
Scanning lamp	[1] activation control by an inverter circuit
Activation control	[2] detection of error
Original size identification	[1] in book mode, sub scanning direction: by reflection type sensor main scanning direction: by CCD [2] in ADF mode: by ADF

T01-101-01

1.2 Major Components

The major components of the original exposure system are as follows:

Component	Notation	Description
Scanning lamp	LA1	xenon lamp (intensity of 35,000 lx)
Scanner motor	M1	2-phase pulse motor (pulse control)
Scanner HP sensor	PS2	photointerrupter (scanner home position detection)
Copyboard cover sensor	PS1	photointerrupter (copyboard cover state (open/closed) detection; identifies as being "closed" when the copyboard is brought down to 30° or lower)
Mirror	---	No. 1/No. 2/No. 3 mirror

T01-102-01

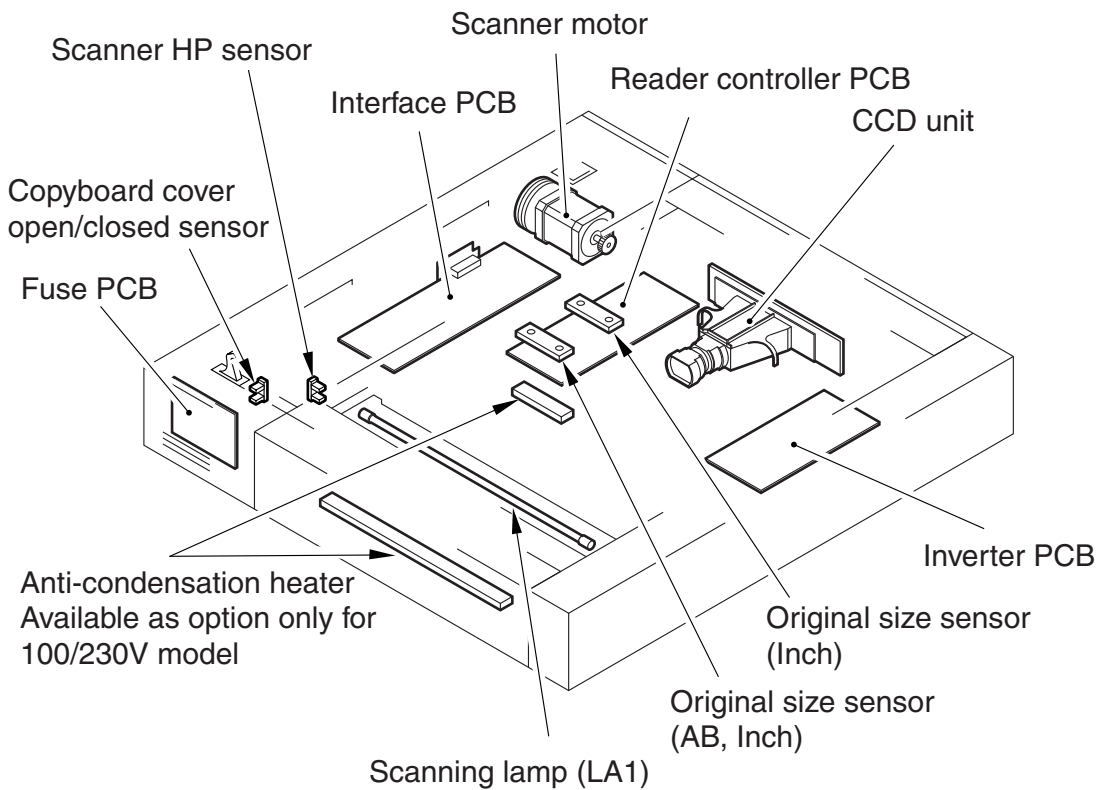

F01-102-01

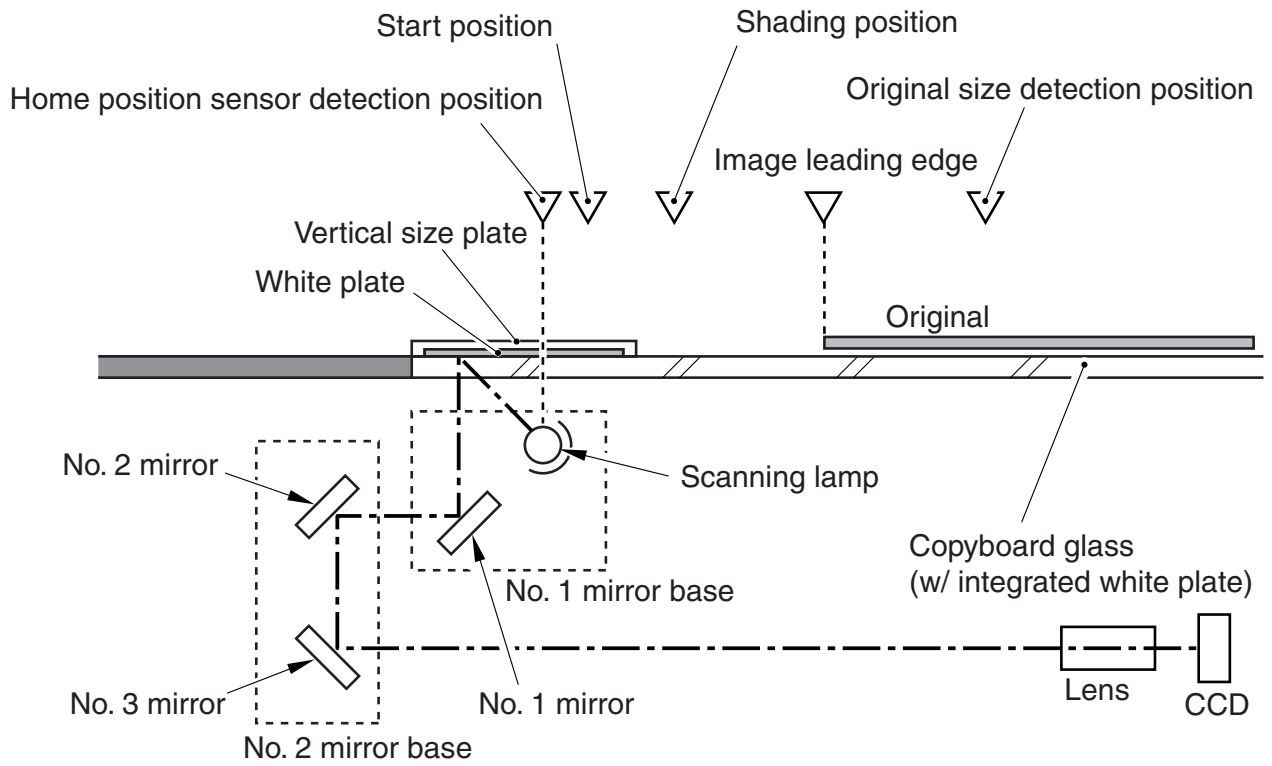

F01-102-02

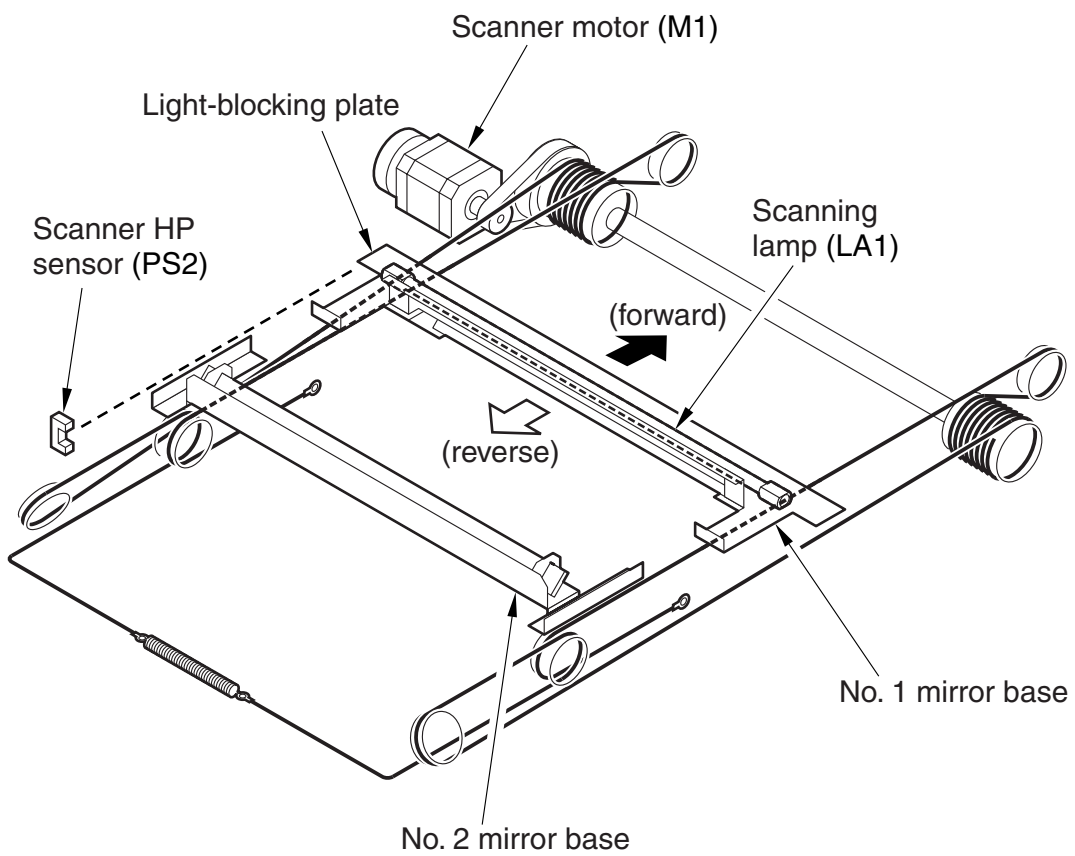

F01-102-03

1.3 Construction of the Control System

The control system of the original exposure system is constructed as follows:

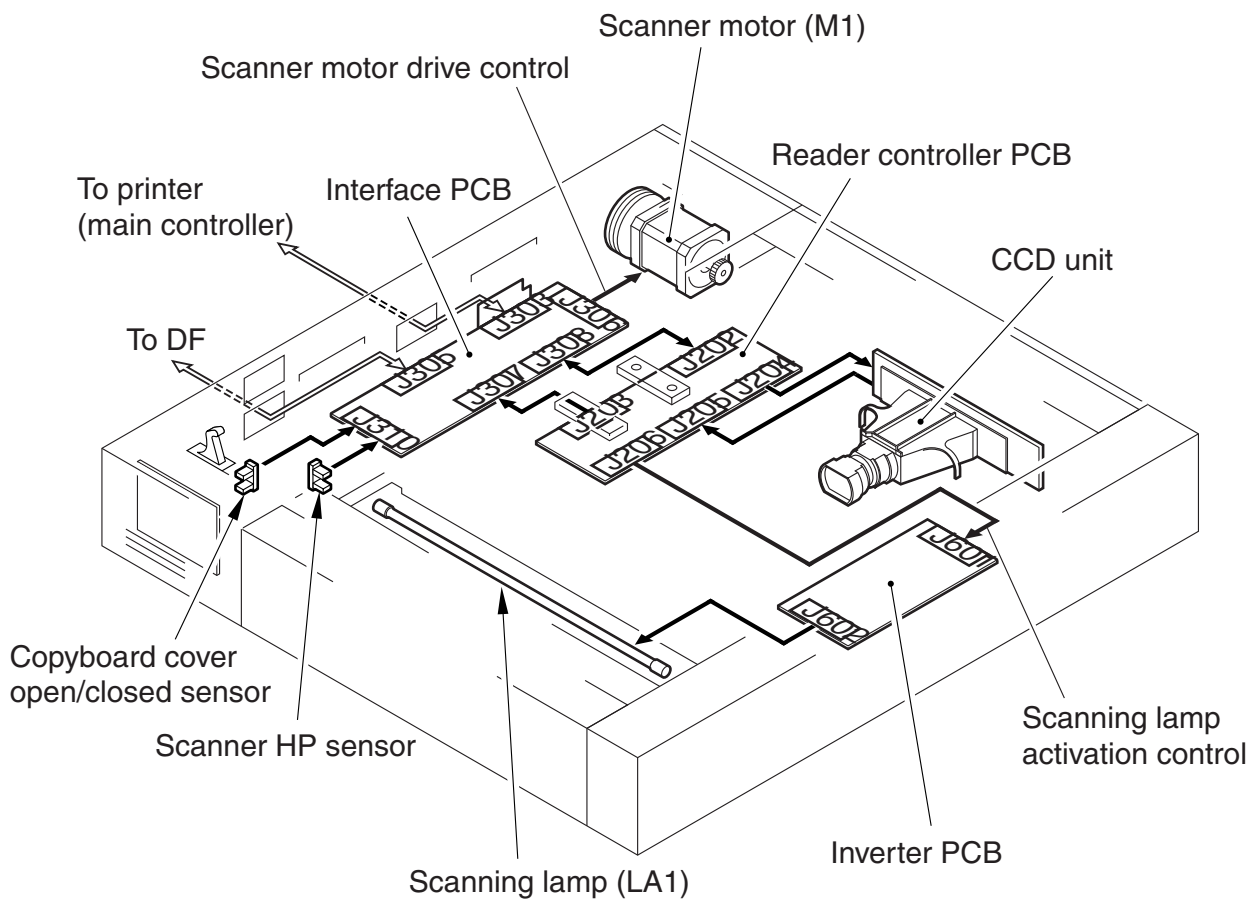

F01-103-01

1.4 Reader Controller PCB

The construction of the functions of the reader controller PCB is as follows:

Image processing (shading correction)

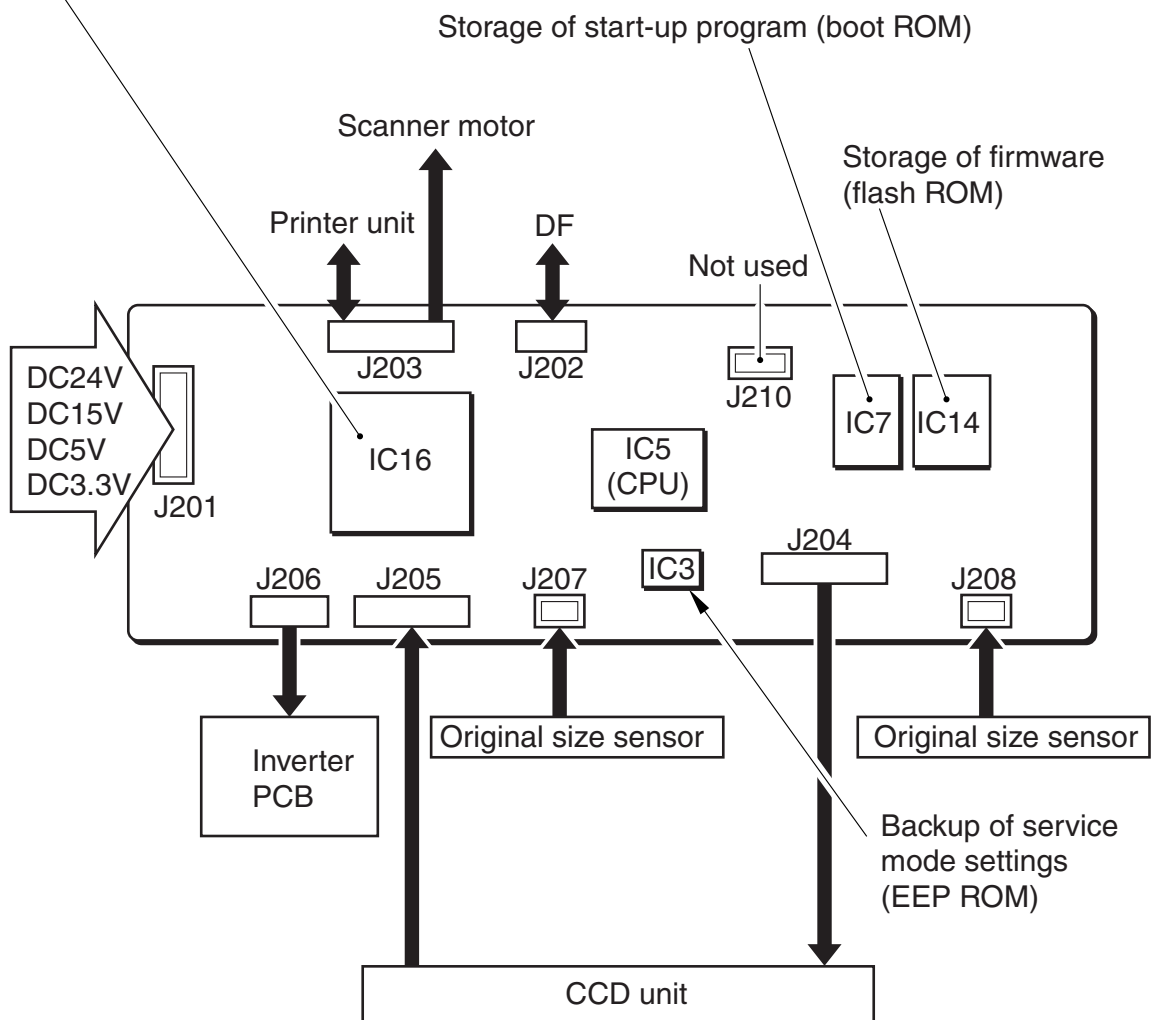

F01-104-01

1.5 Basic Sequence of Operations

1.5.1 Basic Sequence of Operations at Power-On

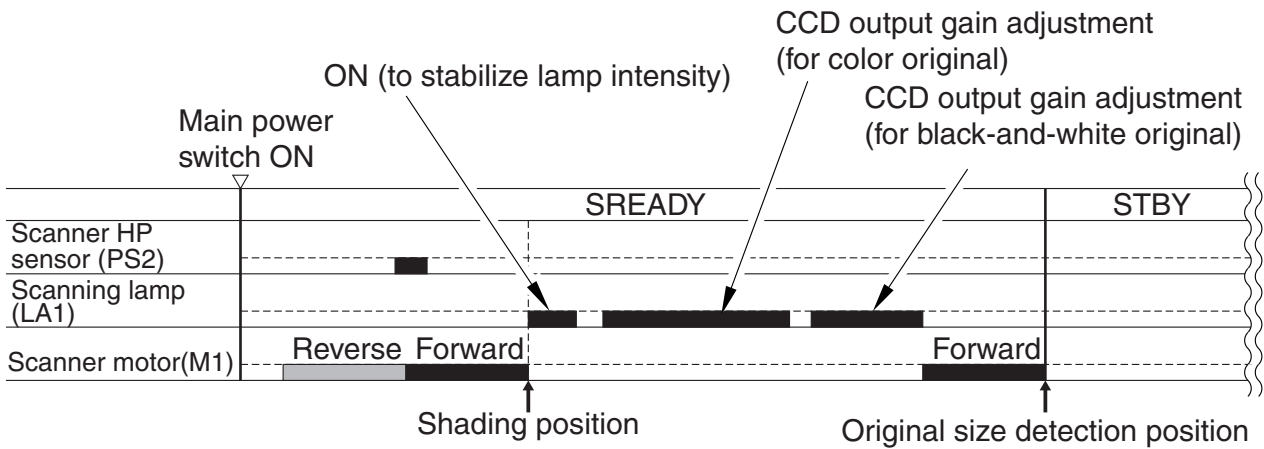

F01-105-01

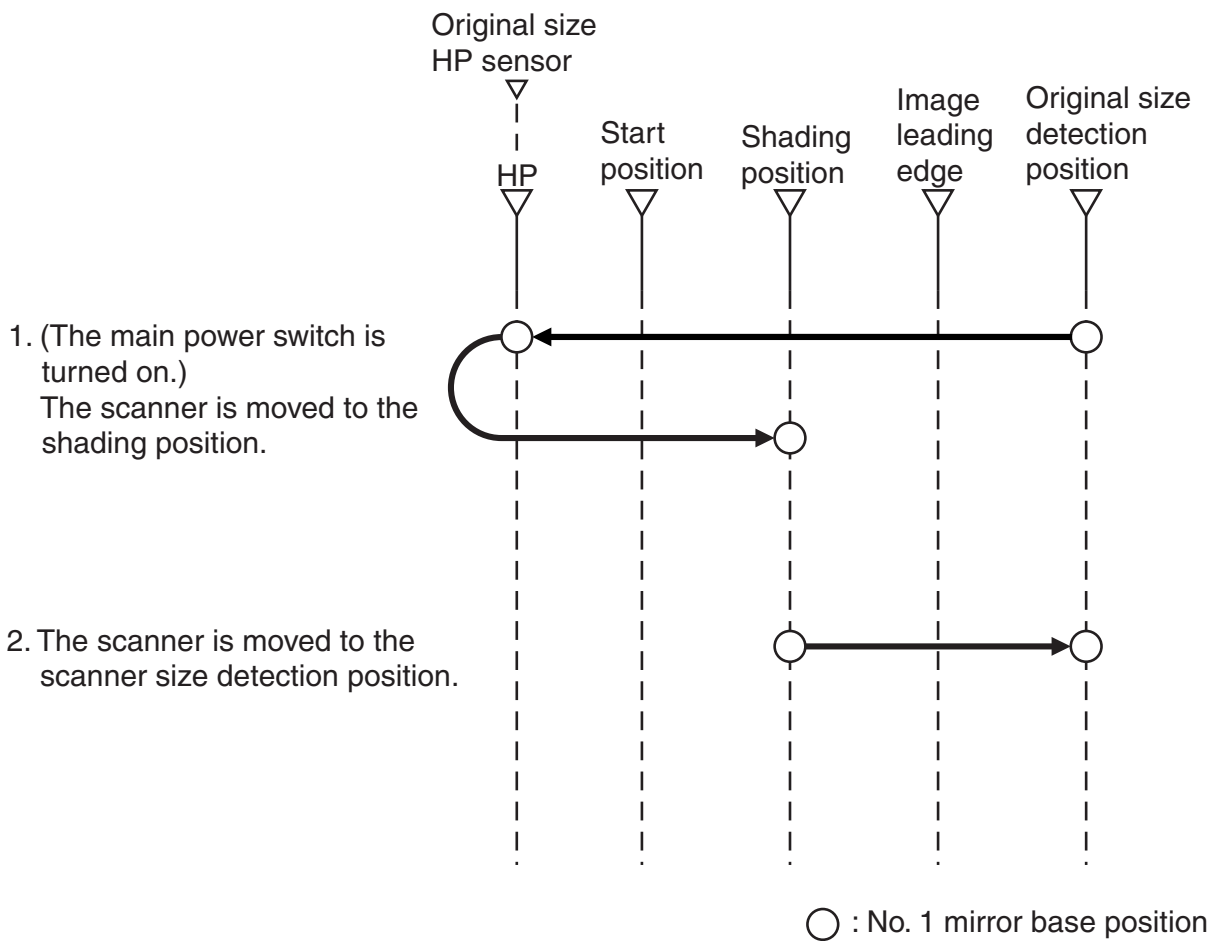

F01-105-02

1.5.2 Basic Sequence of Operations in Response to a Press on the Start Key (book mode, 1 original)

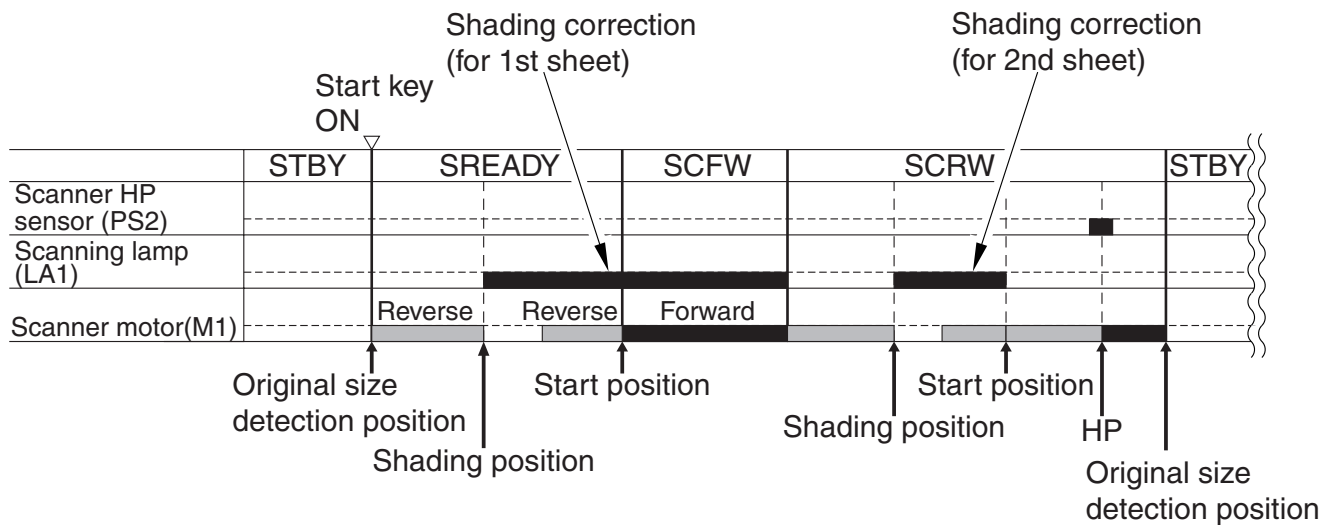

F01-105-03

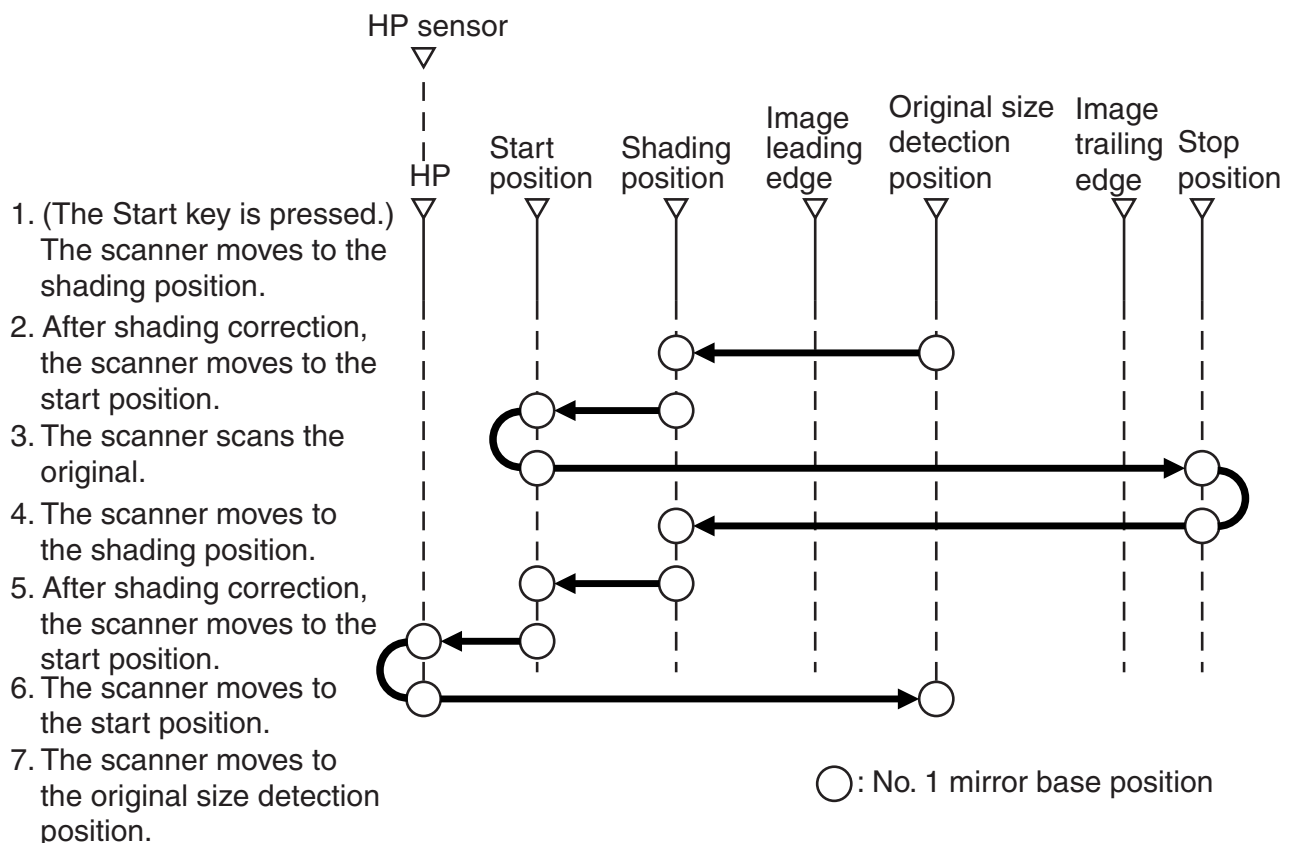

F01-105-04

2 Various Control Mechanisms

2.1 Controlling the Scanner Drive

2.1.1 Outline

The following shows the parts associated with the scanner drive system:

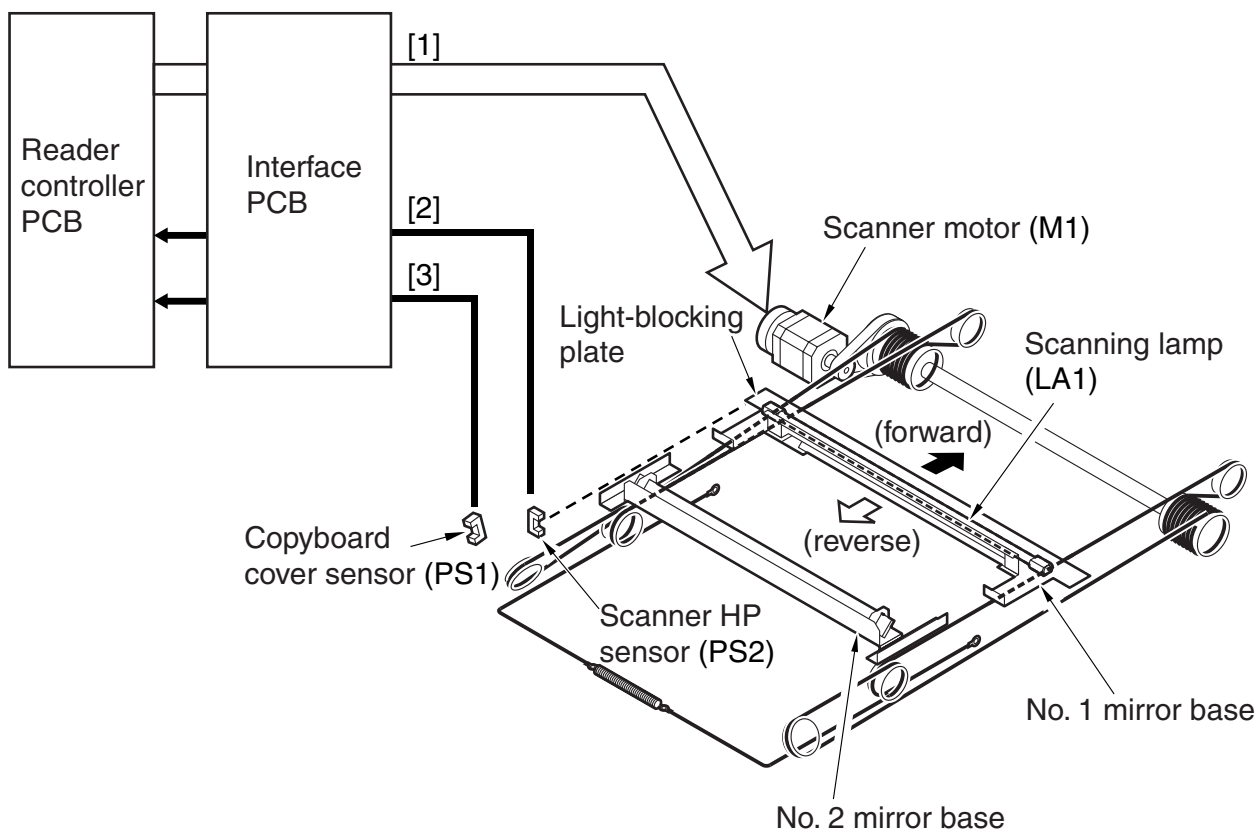

F01-201-01

1. Scanner Motor (M1) Drive Signal
turns on/off the motor, and controls the direction/speed of its rotation.
2. Scanner HP Sensor (PS2) Detection Signal
indicates that the No. 1 mirror base is in the home position.
3. Copyboard Cover Sensor (PS1) Detection Signal
identifies the state (open/closed) of the copyboard cover.

2.1.2 Controlling the Scanner Motor

The following shows the construction of the control system of the scanner motor; the motor driver operates in response to signals from the CPU to turn on/off the scanner motor or to control the direction/speed of its rotation.

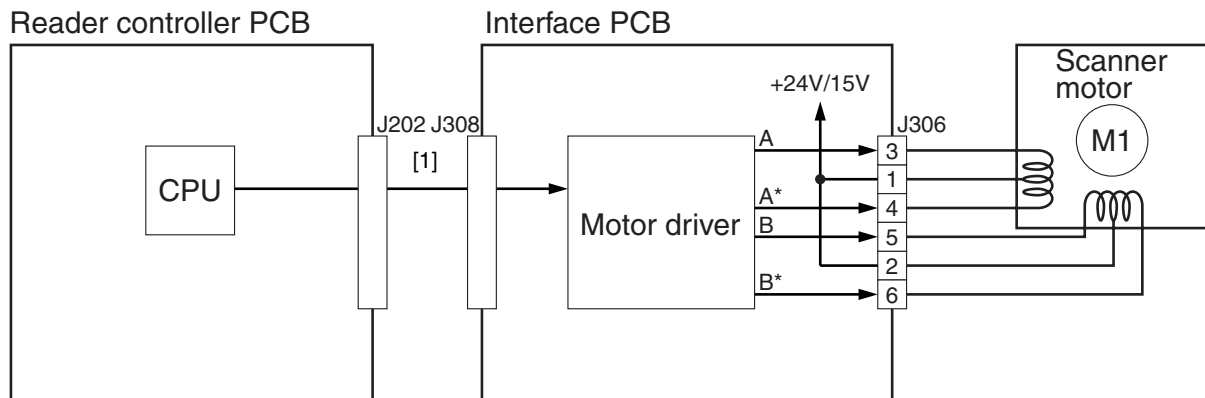

[1] Scanner motor control signal

F01-201-02

a. Moving the Scanner in Reverse for Image Scanning

After scanning an image, the movement of the No. 1 mirror base to the shading position is controlled at a speed twice as high as it is moved to scan an image regardless of the color mode.

b. Moving the Scanner Forward for Image Scanning

To scan an image, the movement of the No. 1 mirror base unit is controlled by the following motor control mechanism:

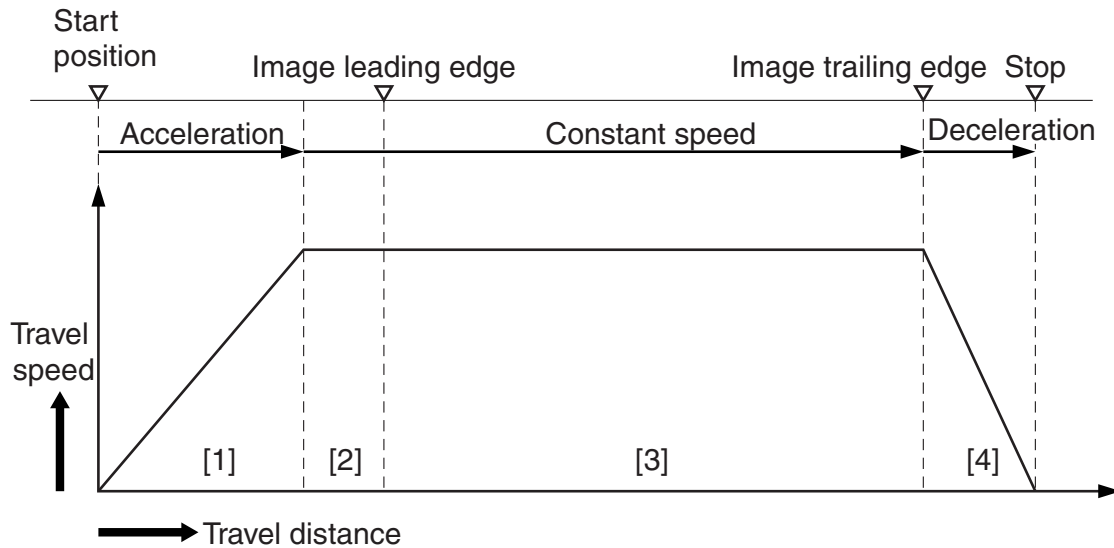

- [1] Acceleration area: accelerates to a speed suited to black-and-white/SEND mode or full-color mode
- [2] Approach speed area: allows a margin of acceleration (approach run) to ensure stable speed
- [3] Reading image area: reads images at specific speed (if black-and-white/SEND mode, twice as fast as in full-color mode)
- [4] Deceleration area: decelerates after the image trailing edge for a stop

F01-201-03



The scanner is moved at the following speed to suit the selected mode:

- in full-color copy mode, 117 mm/sec.
- in black-and-white copy/black-and-white SEND mode, 234 mm/sec
- full-color SEND mode, 234 mm/sec (300 dpi or less);
117 mm/sec (more than 300 dpi)

2.2 Changing the Reproduction Ratio

1. in copyboard cover mode, 100%
2. in ADF mode, 100%



-
- The speed of scanning is 234 mm/sec in black-and-white copy or black-and-white SEND mode (reduction by 50%); to make up for the difference, the reading speed of the CCD is doubled, ultimately resulting in a 100% reproduction ratio.
 - The same is true of a resolution of 300 dpi or less in full-color SEND mode.
-

2.2.1 Changing the Reproduction Ratio in Main Scanning Direction

In copyboard cover mode and ADF mode, reading in main scanning direction is at 100% at all times, and the reproduction ratio is changed through data processing in the main controller.

2.2.2 Changing the Reproduction Ratio in Sub Scanning Direction

In copyboard cover mode and ADF mode, reading in sub scanning direction is at 100% at all times, and the reproduction ratio is changed through data processing in the main controller.

2.3 Turning On/Off the Scanning Lamp (LA1)

2.3.1 Outline

The items of control related to the scanning lamp and the construction of its control system are as follows:

1. turning on/off the lamp
2. checking for a fault

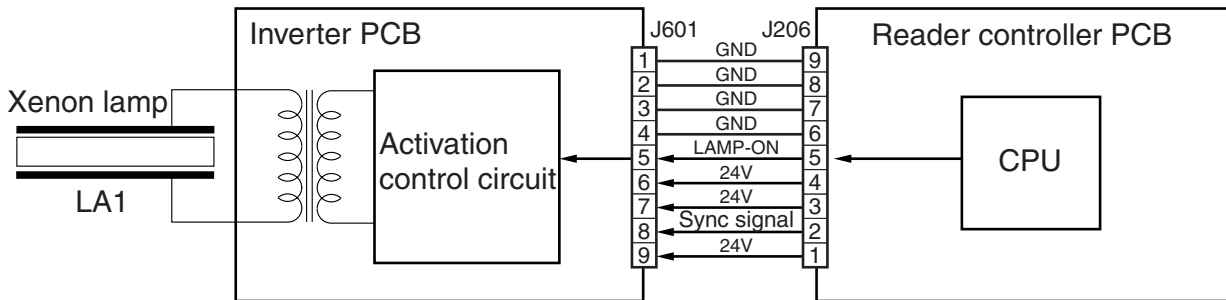

F01-203-01

2.3.2 Scanning Lamp

The machine's scanning lamp is a xenon lamp made up of a glass tube in which xenon gas is sealed. On the outside of the tube are 2 terminals laid in parallel in axial direction, while the inner side of the tube is coated with fluorescent material. When a high frequency, high voltage is applied to the terminals, the gas starts to discharge, thus causing the fluorescent material to emit light.

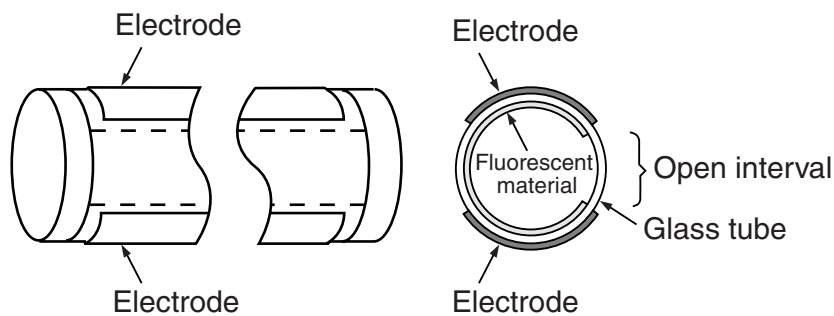

F01-203-02

2.3.3 Turning On/Off the Lamp

The scanning lamp is turned on/off by the drive signal (LAMP_ON) sent by the CPU on the reader controller PCB. When the signal is sent, the inverter PCB generates high-frequency, high voltage in the activation control circuit using the drive voltage (+24 V) supplied by the reader controller PCB for the activation of the xenon lamp.

2.3.4 Checking for an Error

At time of initial activation (e.g., shading correction), the lamp is checked for a fault (low intensity, activation failure; i.e., activation error caused by lack of intensity).



E220 (lamp activation error at power-on)

Indicates a fault in the inverter PCB, reader controller PCB, or scanning lamp.

2.4 Identifying the Size of Originals

2.4.1 Outline

The machine identifies the size of originals with reference to the combinations of the outputs of reflection type sensors and the intensities of the CCD measured at specific points.

- in main scanning direction, of CCD (for AB, 4 points; for Inch, 2 points)
- in sub scanning direction, of reflection type photosensor (for AB, 1 point; for Inch, 2 points)

The machine identifies the size of an original using the following steps:

1. Search for External Light (main scanning direction only)

With the scanning lamp OFF, the level of the CCD at each point of detection is measured.

2. Detection of the Sensor Output Level

The scanning lamp is turned on, and the CCD level at each point of detection in main scanning direction is measured. In addition, the LED of the reflection type photosensor in sub scanning direction is turned on to measure the output of the sensor.

The combination of these outputs is used to identify the size of the original. For specific operation, see the pages that follow.

2.4.2 Points of Detection (original size)

For main scanning direction, the No. 1 mirror base is moved to the following positions to measure the intensity of light at each point of detection. For sub scanning direction, the outputs of the sensors mounted at the following points are used.

AB-configuration

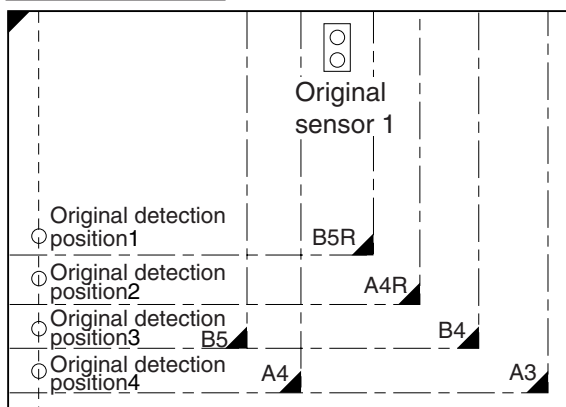

CCD original detection position

Inch-configuration

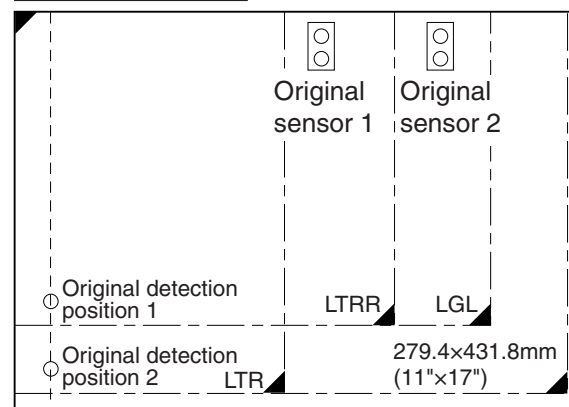

CCD original detection position

F01-204-01

2.4.3 Outline of Detection Operations

a. Book Mode, 1 Original, Copyboard Cover Closed

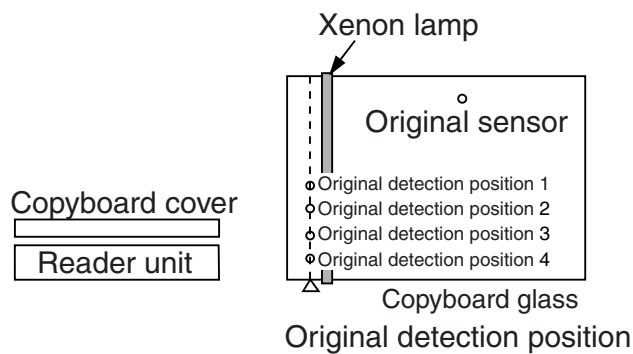

- The machine is in a standby state.
No. 1 mirror base: at original detection position
xenon lamp: OFF
original sensor: OFF

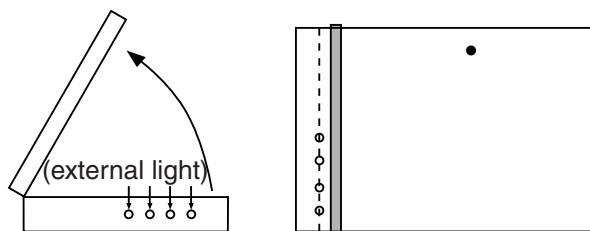

- The copyboard cover is opened.
No. 1 mirror base: at original detection point
xenon lamp: OFF
original sensor: OFF

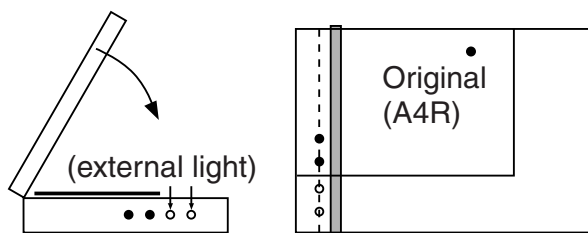

- The copyboard cover is closed.
 - If the external light is blocked, the machine assumes the presence of an original; outside the area, where light is detected, the machine assumes that there is no original. (search for external light)
At this point in time, B5, B4, A4, and A3 are excluded.

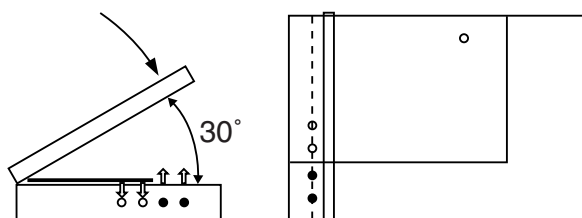

- When the copyboard cover is brought to 30°, the copyboard cover sensor identifies the condition to be "cover closed," thus causing the machine to start original size detection.
- After a search for external light, the machine turns on the xenon lamp (for main scanning direction), and checks the reflected light by the CCD at 4 points. For sub scanning direction, the machine refers to the outputs of original sensors.

F01-204-02

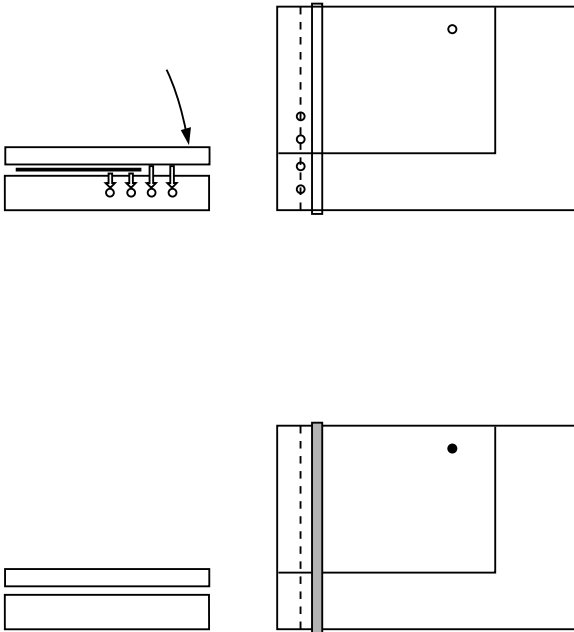

4. The copyboard cover is fully down. The machine monitors the outputs of the sensors for 5 sec after the copyboard cover sensor has identified a "closed" state. If there is no change in the level, the machine assumes the presence of an original at the sensor. The machine uses the combination of the outputs (changes) at 5 points.

5. The machine is in a standby state (waiting for a press on the Start key).
 No. 1 mirror base: at original detection position
 xenon lamp: OFF
 original sensor: OFF

F01-204-03

AB-configuration

Original size	CCD detection position				Original sensor 1
	1	2	3	4	
A3	○	○	○	○	○
B4	○	○	○	●	○
A4R	○	○	●	●	○
A4	○	○	○	○	●
B5	○	○	○	●	●
B5R	○	●	●	●	○
None	●	●	●	●	●

Inch-configuration

Original size	CCD detection position		Original sensor 1	Original sensor 2
	1	2		
11" X 17"	○	○	○	○
LGL	○	●	○	○
LTRR	○	●	○	●
LTR	○	○	●	●
None	●	●	●	●

○:change absent ●: change present

T01-204-01

3 Assembly and Disassembly

3.1 Removing the Copyboard Glass

- 1) Open the ADF or the copyboard cover.
- 2)



When removing the copyboard glass, take care not to touch the surface of the glass or the white plate behind it. (The presence of dirt will cause lines in the images.)

If dirt is found, be sure to remove it using lint-free paper moistened with alcohol.

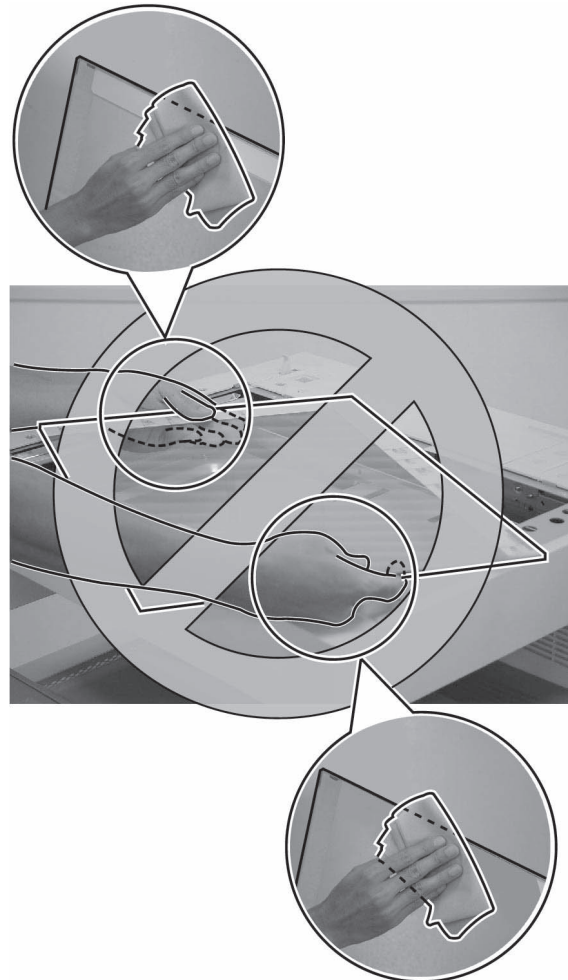

F01-301-01

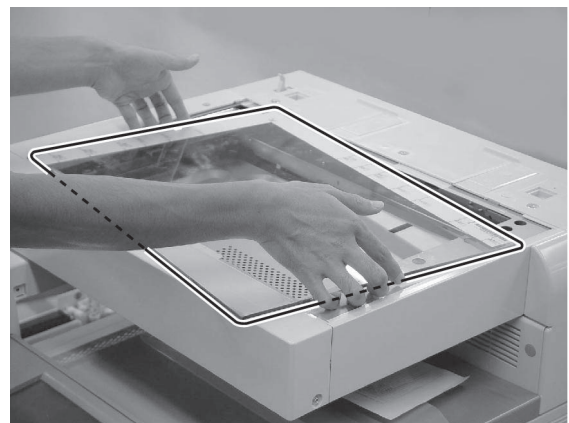

F01-301-02

- 3) Remove the 2 screws [1], and detach the right glass retainer [2]; then, detach the copyboard glass [3].

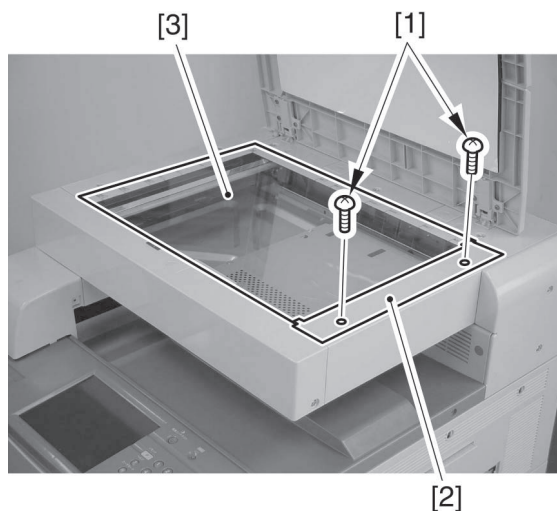

F01-301-03

3.1.1 After Replacing the Copyboard Glass

Enter the value indicated on the copyboard glass (F01-301-04) using the following service mode items:

```
COPIER>ADJUST>CCD>W-PLT-X  
COPIER>ADJUST>CCD>W-PLT-Y  
COPIER>ADJUST>CCD>W-PLT-Z
```

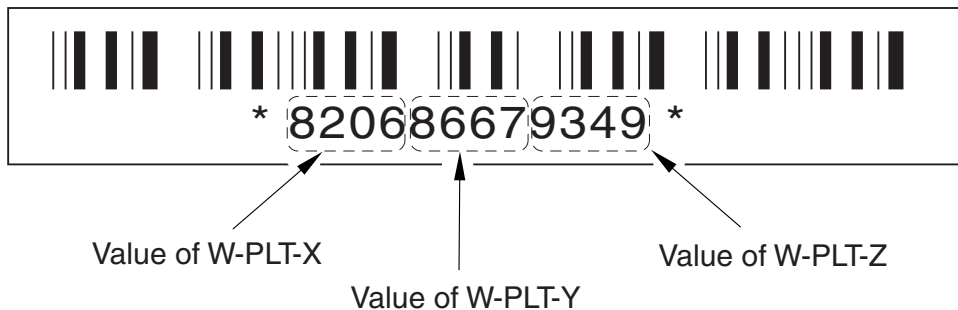

F01-301-04

3.2 Removing the Interface PCB

- 1) Remove the copyboard cover while observing the points to note indicated under 3.1 'Removing the Copyboard Glass.'
- 2) Remove the 2 cable clamps [1] to free the reader power cable.

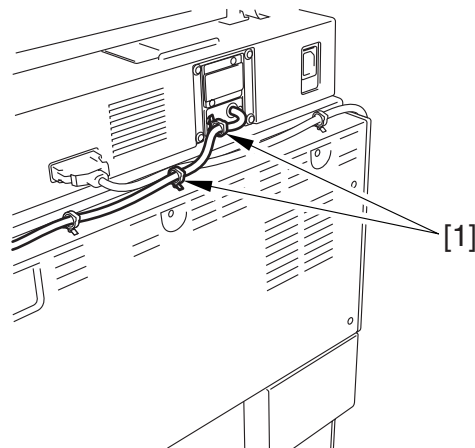

F01-302-01

- 3) Disconnect the reader controller communications cable.
- 4) Remove the 7 screws [1], and detach the reader rear cover [2].

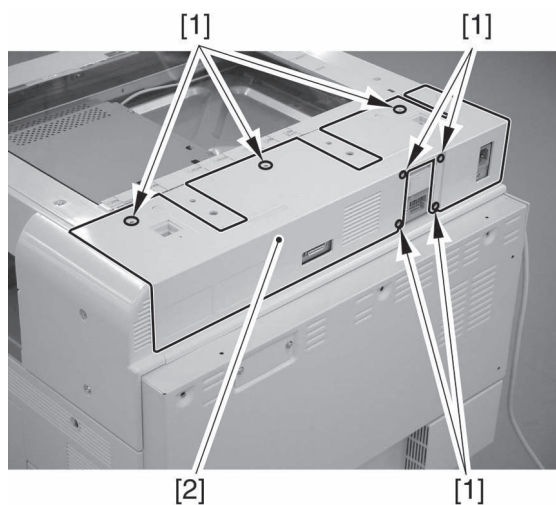

F01-302-02

- 5) Remove the 2 RS tightening screws and 4 binding screws [2]; then, detach the I/F PCB cover [3].

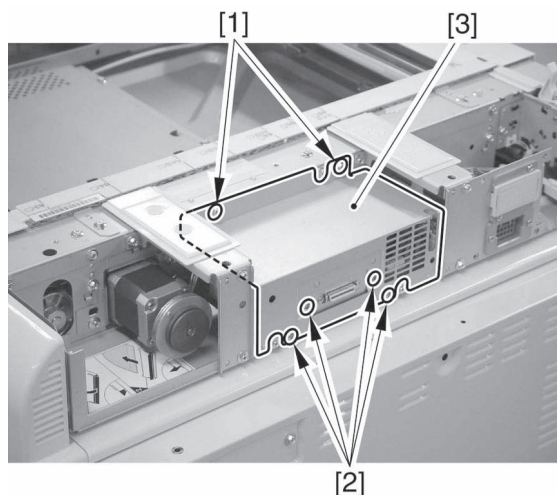

F01-302-03

- 6) Remove the 2 screws [1], and disconnect the 2 connectors [2]; then, detach the connector base [3].

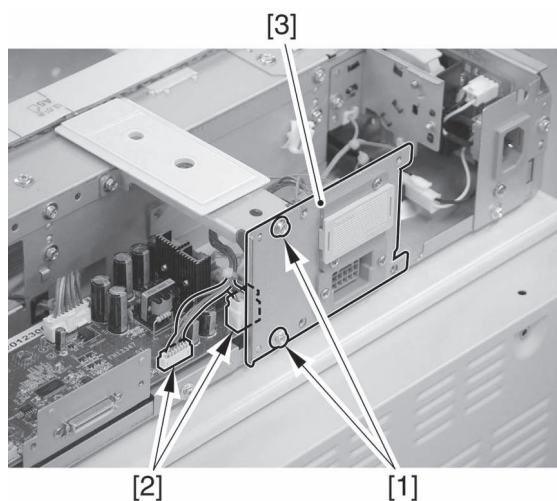

F01-302-04

- 7) Disconnect the 4 connectors [1] and the 2 flat cables [2], and remove the 5 screws [3]; then, detach the interface PCB unit [4].

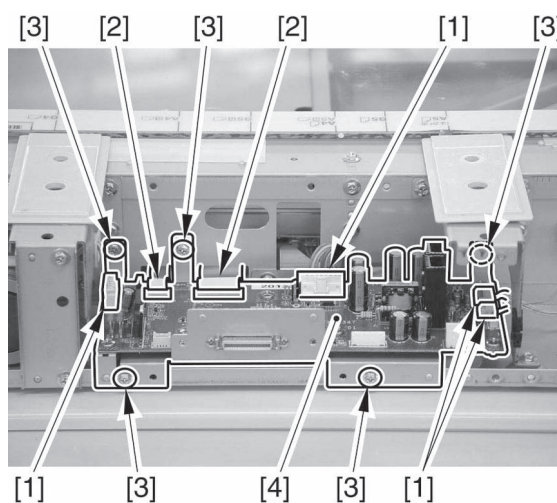

F01-302-05

3.3 Removing the Copyboard Cover Open/Closed Sensor

- 1) Remove the reader rear cover.
- 2) Remove the 2 screws [1], and detach the sensor base [2].

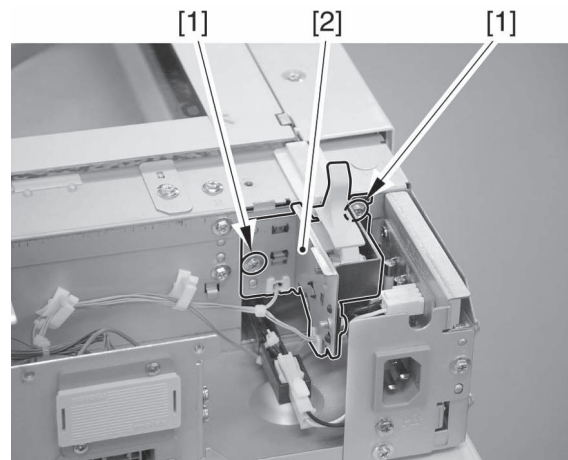

F01-303-01

- 3) Disconnect the connector [1], and remove the screws [2]; then, detach the sensor cover [3].

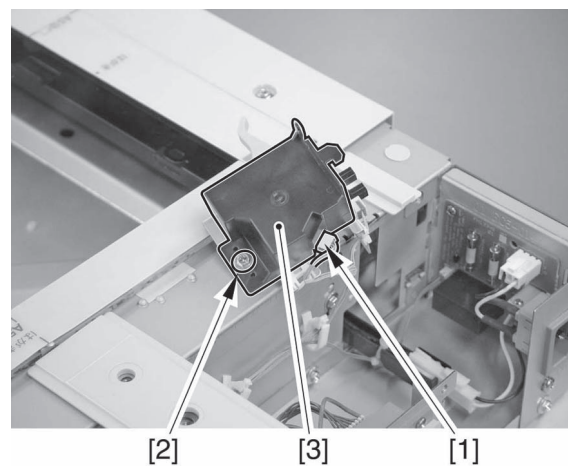

F01-303-02

- 4) Remove the copyboard cover open/closed sensor [1].



[1]

F01-303-03

3.4 Removing the Mirror Base Home Position Sensor

- 1) Remove the reader rear cover.
- 2) Remove the 2 screws [1], and detach the sensor base [2].

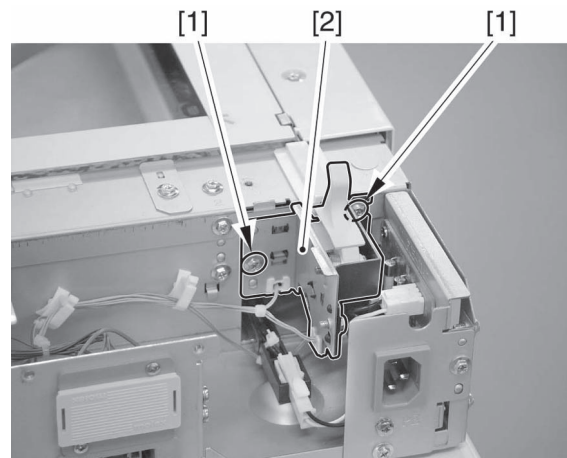

F01-304-01

- 3) Disconnect the connector [1], and detach the mirror base home position sensor [2].

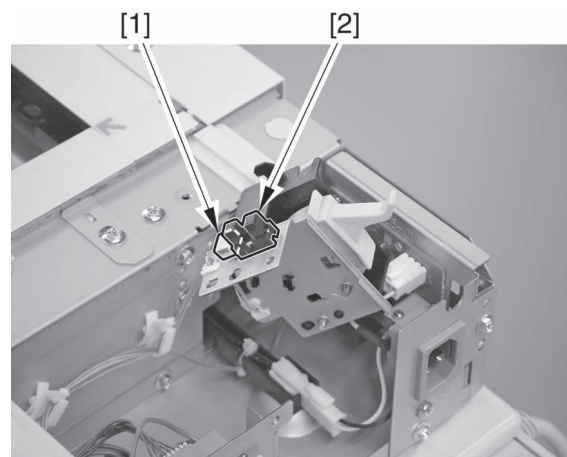

F01-304-02

3.5 Removing the Fuse PCB Unit (option; 100/230V model only)

- 1) Remove the reader rear cover.
- 2) Remove the sensor base.
- 3) Disconnect the 2 connectors [1], and remove the 2 screws [2]; then, remove the fuse PCB unit [3].

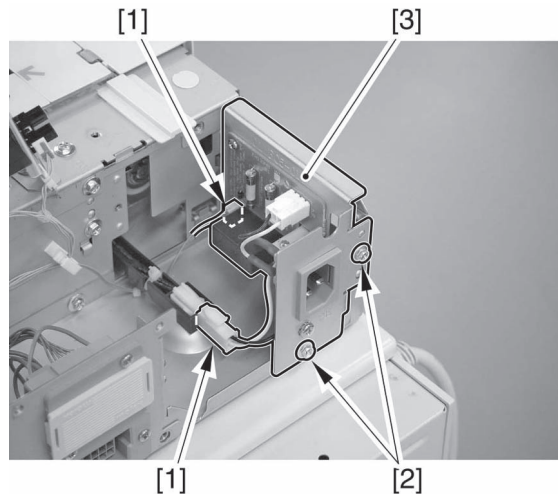

F01-305-01

3.6 Removing the Anti-Condensation Heater (option; 100/230V model only)

- 1) Remove the copyboard glass while observing the points to note indicated under 3.1 'Removing the Copyboard Glass.'
- 2) Remove the reader rear cover.
- 3) Remove the fuse PCB unit.
- 4) Move the No. 1 mirror base [1] into the direction of the arrow.

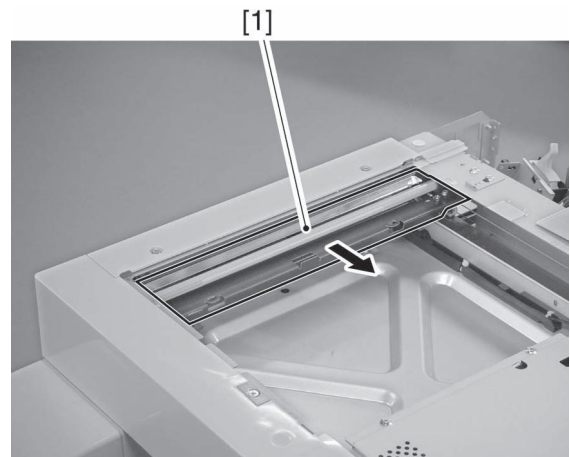

F01-306-01



When moving the mirror base, be sure to hold the cut-up [A] on the mirror stay.

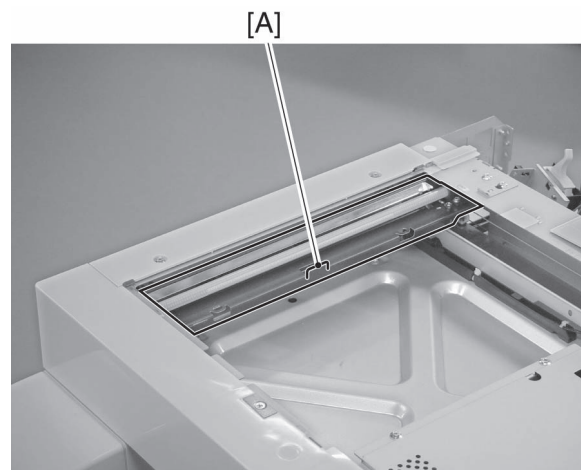

F01-306-02

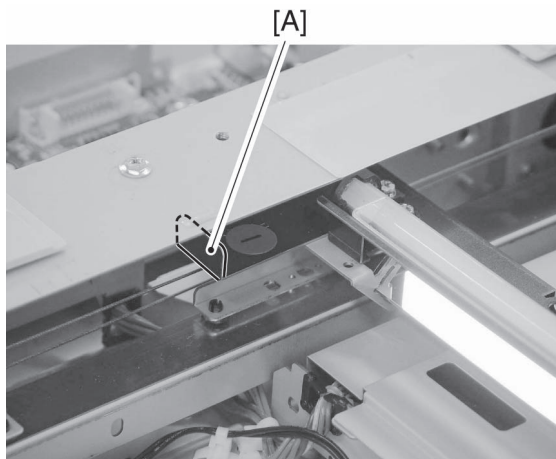

F01-306-03

- 5) Remove the 3 screws used to secure the anti-condensation heater [1] in place, and remove the harness band [3].

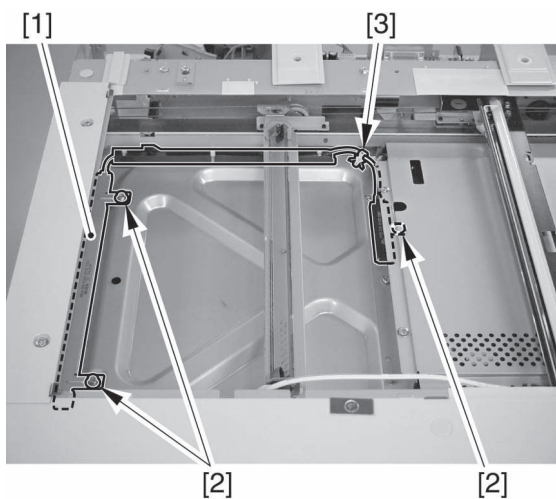

F01-306-04

- 6) Shift the mirror base to the farthest right, and free the harness guide [1] at one location; then, while shifting it to the left, detach the harness guide, and detach the anti-condensation heater [2].

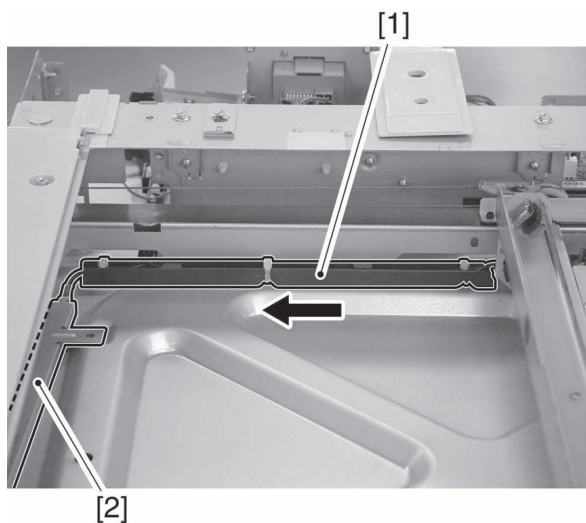

F01-306-05

3.7 Removing the Scanner Motor

- 1) Remove the reader rear cover.
- 2) Without detaching the motor unit, mark its position of the rear side plate using a scribe [A].

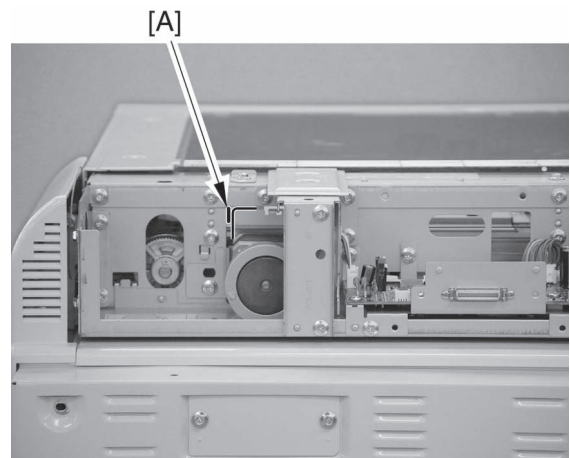

F01-307-01

- 3) Remove the interface PCB unit. (See 3.1 'Removing the Interface PCB.')
- 4) Remove the 5 screws [1], and detach the DF base [2].

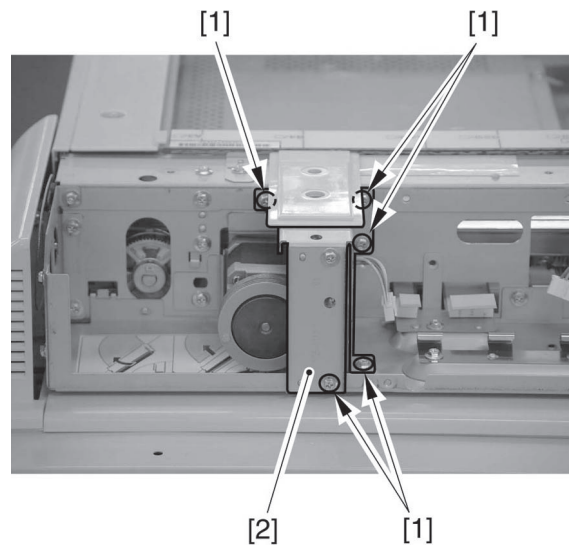

F01-307-02

- 5) Remove the 3 screws [1], and detach the scanner motor [2].

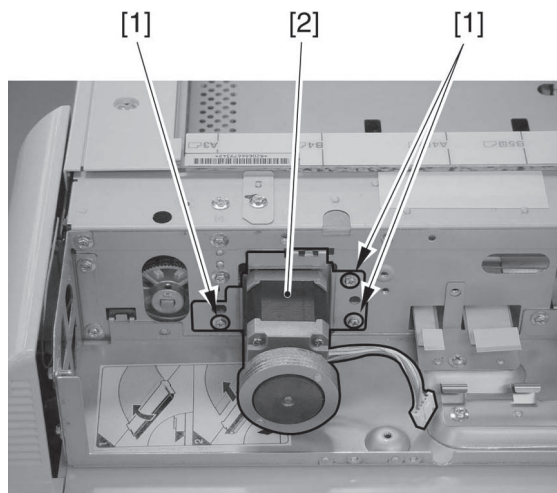

F01-307-03

3.7.1 Mounting the Scanner Motor

- 1) Remove the copyboard glass according to the instructions under 3.1 ‘Removing the Copyboard Glass.’
- 2) Fit the scanner motor from the machine’s rear, and attach the belt [1] on the pulley [2] of the motor unit through the space (front side) vacated by the copyboard glass.

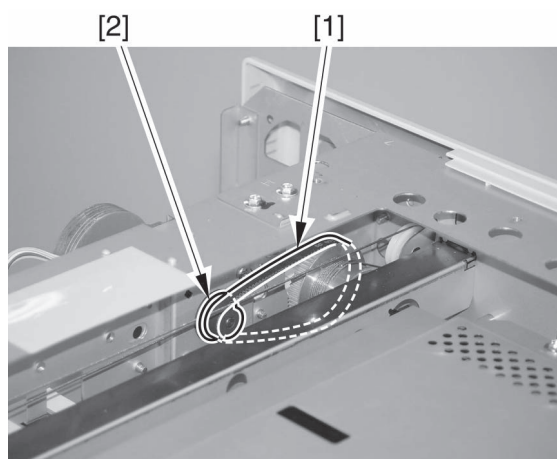

F01-307-04

- 3) With the belt on the pulley, pull the motor unit [1] as far as the marking [A] you have drawn with a scribe; then, secure it in place with 3 screws [2].

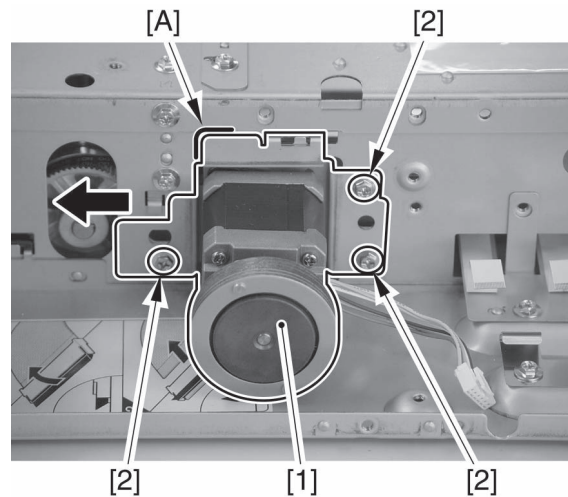

F01-307-05

3.7.2 Checking the Operation After Mounting the Scanner Motor

When you have mounted the motor, either move the mirror or make a test print (so as to be sure that the motor belt is correctly placed).

3.8 Removing the Scanning Lamp

- 1) Remove the reader left cover, reader right cover, and reader front cover.
- 2) Remove the 8 screws [1], and detach the lens cover [2].

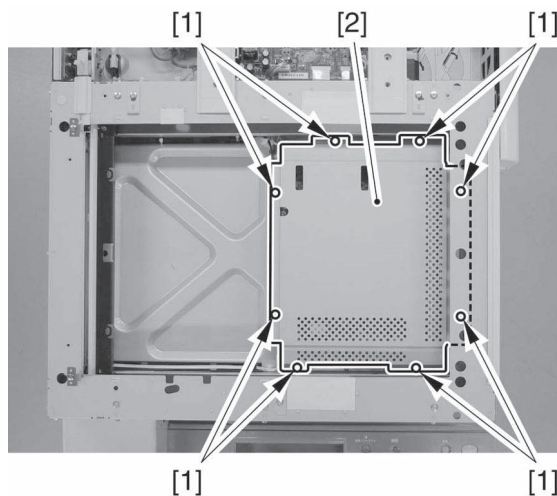

F01-308-01

- 3) Peel the sheet [1] (1 each at front and rear) of the reader frame.

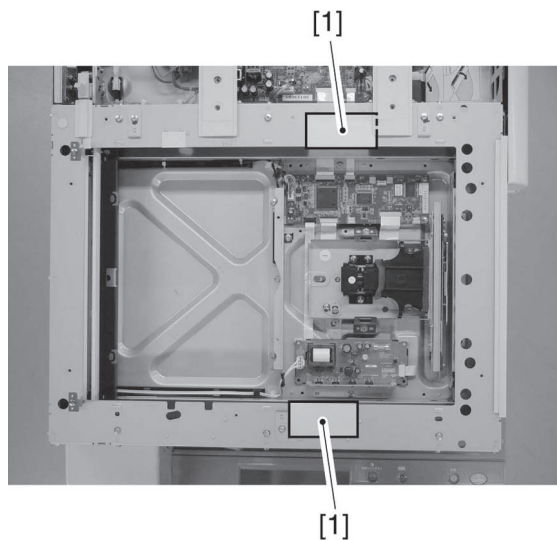

F01-308-02

- 4) Disconnect the connector [1] from the inverter PCB, and free the harness [3] from the edge saddle [2] of the frame.

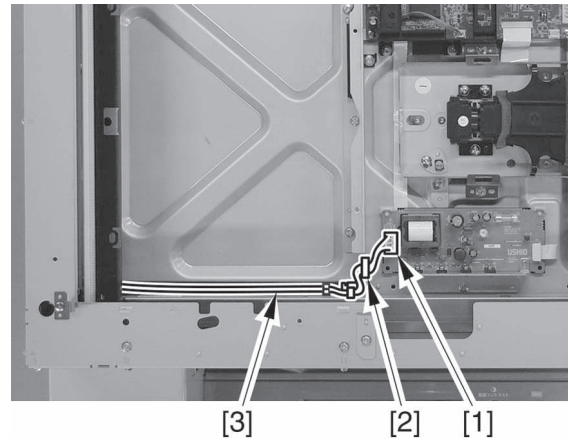

F01-308-03

- 5) Slide the No. 1 mirror base [1] until it matches against the cut-off in the frame; then, remove the 3 screws [2], and remove the scanning lamp [3].

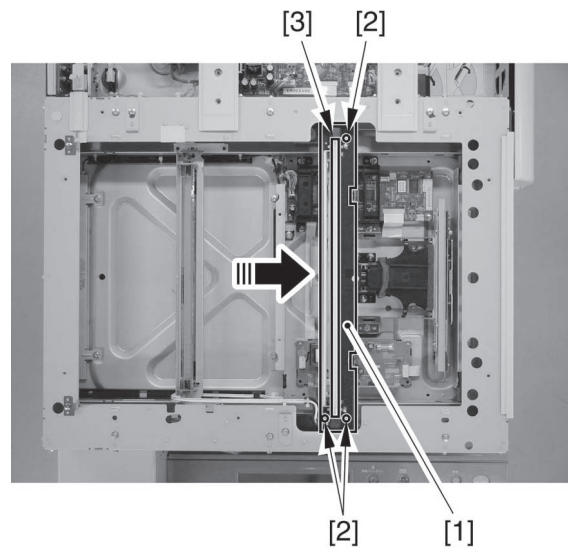

F01-308-04



To mount the scanning lamp, route the harness [1] of the lamp unit through the white guide [2] of the No. 2 mirror base and then the black harness guide [3]; thereafter, connect the connector [4] to the inverter PCB.

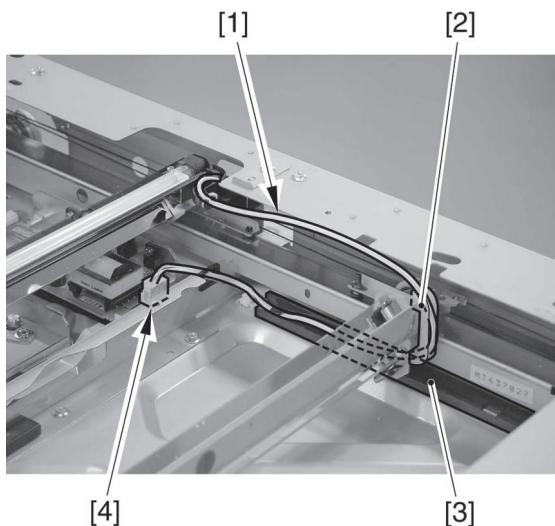

F01-308-05

3.9 Removing the Original Size Sensor

- 1) Remove the copyboard glass according to the instructions under 3.1 'Removing the Copyboard Glass.'
- 2) Remove the lens cover. (See 3.8 'Removing the Scanning Lamp.')
- 3) Disconnect the connector [1], and remove the 4 screws [2]; then, detach the original size detection unit [3].

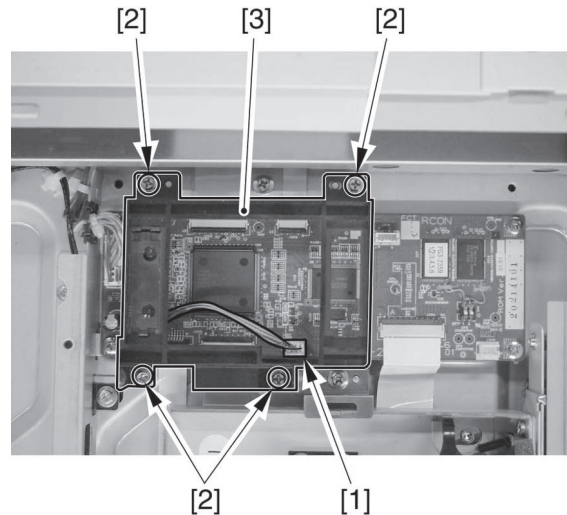

F01-309-01

- 4) While freeing the claw at the edge, detach the original size sensor [1].

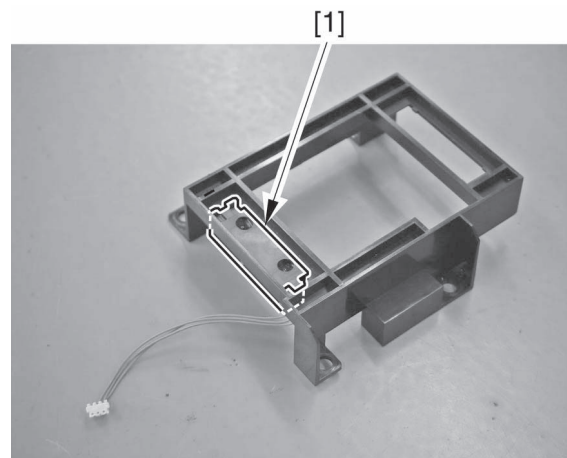

F01-309-02

3.10 Removing the CCD Unit

- 1) Remove the copyboard glass according to the instructions under 3.1 'Removing the Copyboard Glass.'
- 2) Remove the CCD unit cover. (See 3.8 'Removing the Scanning Lamp.')
- 3) Remove the original size detection unit.
- 4) Remove the 2 flat cables [1] of the reader controller PCB, 2 screws [2], and leaf spring [3]; then, detach the CCD unit [4].

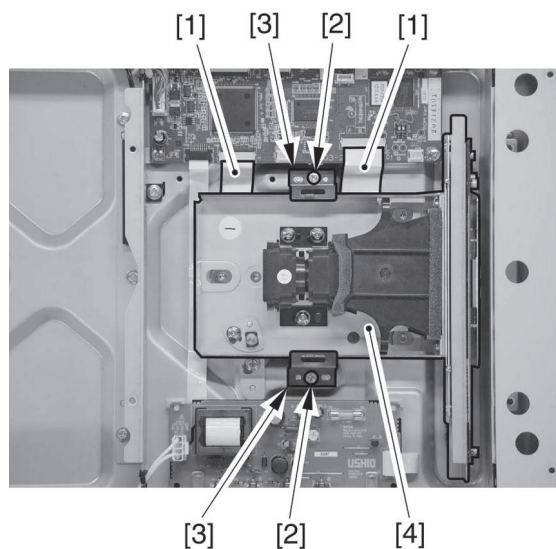

F01-310-01

3.10.1 After Replacing the CCD Unit

When you have replaced the CCD unit, enter the values (for color displacement correction in sub scanning direction) indicated on the label attached to the unit in service mode:

COPIER>ADJUST>CCD>CCDU-RG

COPIER>ADJUST>CCD>CCDU-GB

3.11 Removing the Inverter PCB

- 1) Remove the copyboard glass according to the instructions under 3.1 ‘Removing the Copyboard Glass.’
- 2) Remove the lens cover. (See 3.8 ‘Removing the Scanning Lamp.’)
- 3) Disconnect the connector [1], and remove the flat cable; then, remove the screw [3], and detach the inverter PCB [4].

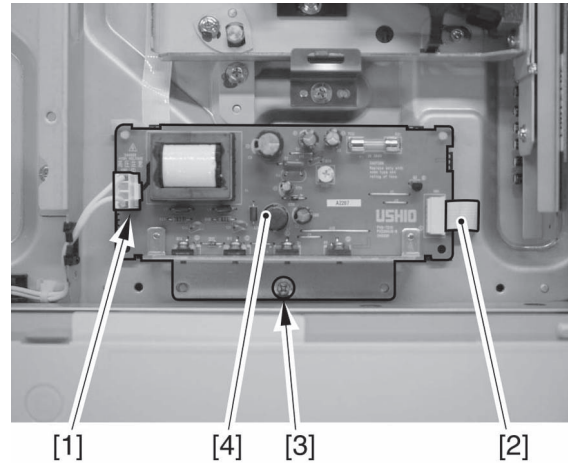

F01-311-01

3.12 Removing the Reader Controller PCB

- 1) Remove the copyboard glass according to the instructions under 3.1 ‘Removing the Copyboard Glass.’
- 2) Remove the lens cover. (See 3.8 ‘Removing the Scanning Lamp.’)
- 3) Remove the original size detection unit.
- 4) Remove the 5 flat cables [1], disconnect the connector [2], and remove the 4 screws [3]; then, detach the reader controller PCB [4].

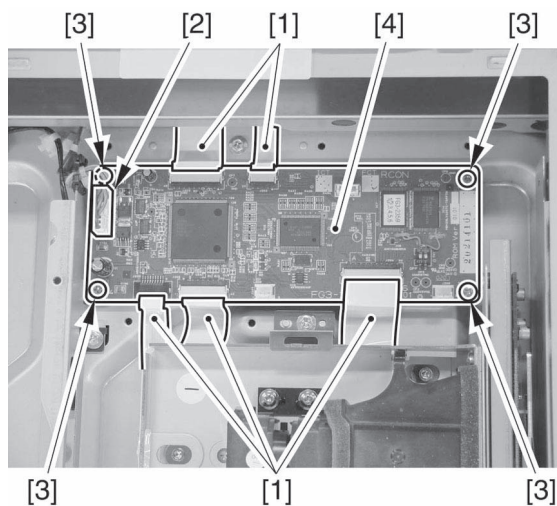

F01-312-01

3.12.1 When Replacing the Reader Controller PCB

- Set the DIP switch on the reader controller PCB to the same settings as the initial PCB.

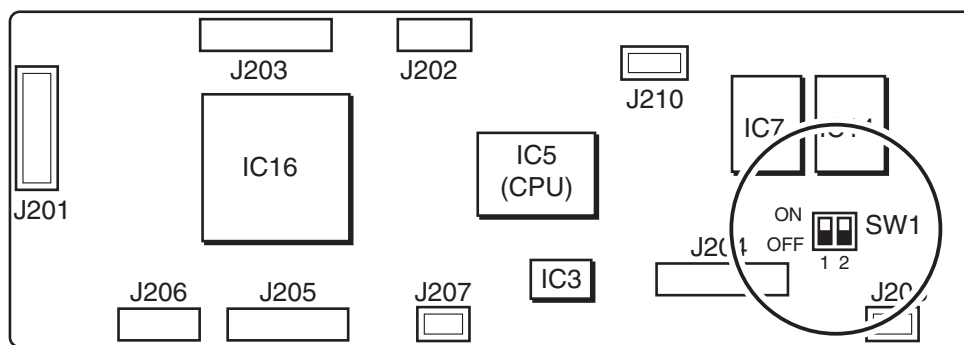

F01-312-02

	SW-1	SW-2
AB	OFF	OFF
A	ON	OFF
A/INCH	OFF	ON
AB/INCH	ON	ON

- Using the SST, download the latest firmware. (See Chapter 6 ‘Upgrading.’)
- Enter the values indicated on the service label in service mode (refer to the following list).

```

COPIER>ADJUST>ADJ-XY>ADJ-X
COPIER>ADJUST>ADJ-XY>ADJ-Y
COPIER>ADJUST>ADJ-XY>ADJ-S
COPIER>ADJUST>CCD>W-PLT-X
COPIER>ADJUST>CCD>W-PLT-Y
COPIER>ADJUST>CCD>W-PLT-Z
COPIER>ADJUST>CCD>CLF-R-RG
COPIER>ADJUST>CCD>CLF-R-GB
COPIER>ADJUST>CCD>CL-R-RG
COPIER>ADJUST>CCD>CL-R-GB
COPIER>ADJUST>CCD>BW-R-RG
COPIER>ADJUST>CCD>BW-R-GB
COPIER>ADJUST>CCD>CCDU-RG
COPIER>ADJUST>CCD>CCDU-GB
COPIER>ADJUST>CCD>FCCDU-RG
COPIER>ADJUST>CCD>FCCDU-GB

```

CHAPTER 2

IMAGE PROCESSING

1 Outline

1.1 Specifications, Control Mechanisms, and Functions

The machine's image processing system has the following specifications and functions:

1. CCD (image sensor)
 - number of lines: 3 (RGB, 1 line each)
 - number of pixels: 7350
 - size of pixel: $9.3 \times 9.3 \mu\text{m}$
2. Shading Correction
 - shading adjustment: executed in service mode
 - shading correction: executed for each copy

1.2 Functional Construction of the PCBs

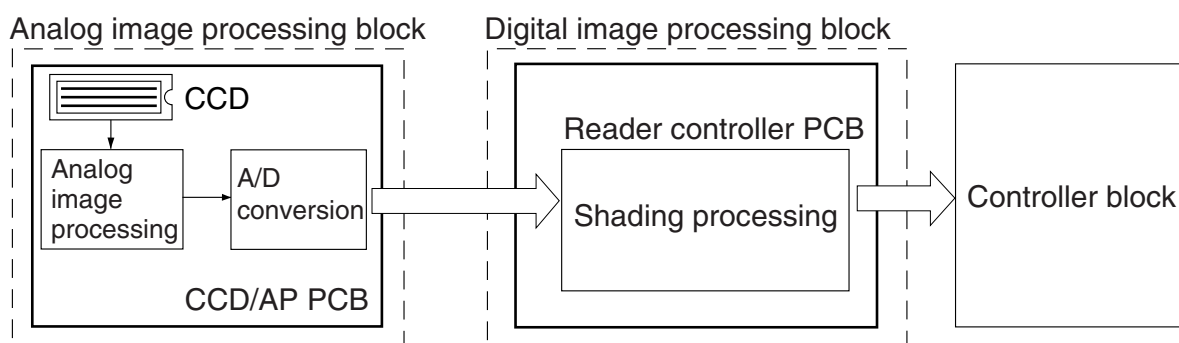

F02-102-01

The PCBs of the image processing system have the following functions:

1. CCD/P PCB: CCD drive, analog image processing, A/D conversion
2. Reader Controller PCB: shading correction

2 Analog Image Processing

2.1 Outline

The machine uses the CCD/AP PCB to perform analog image processing for each RGB line; the major operations involved are as follows:

1. CCD drive
2. CCD output gain correction, offset correction
3. CCD output A/D conversion

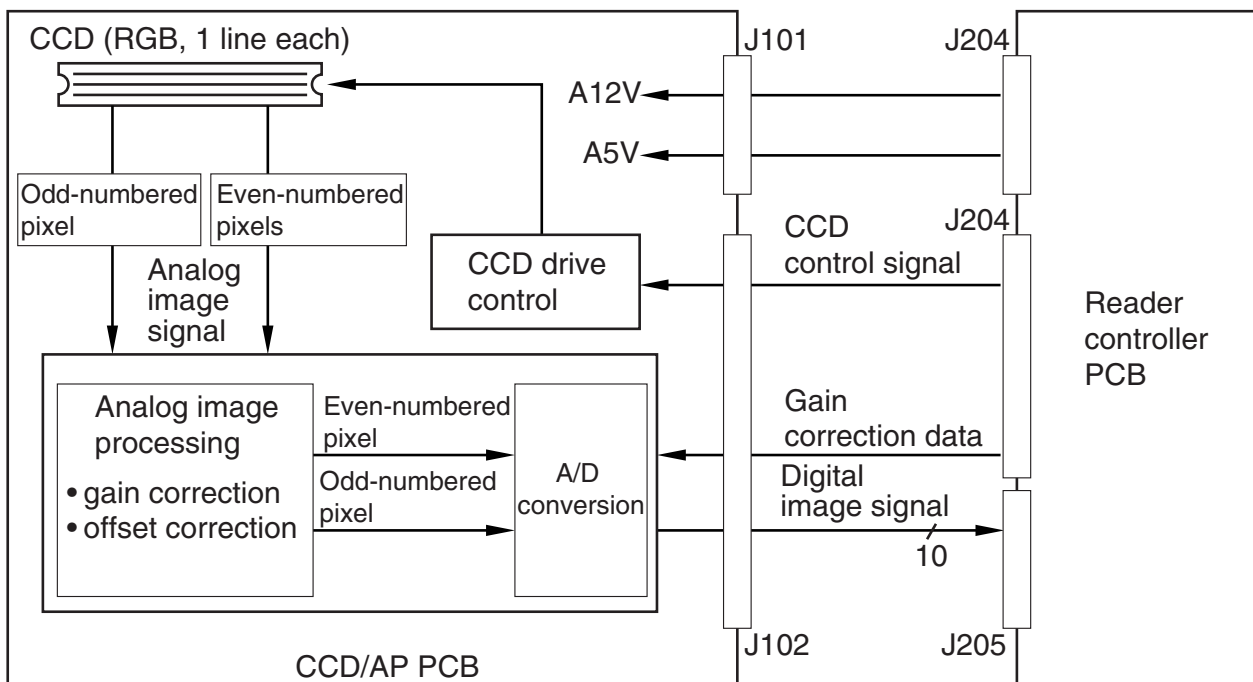

F02-201-01

2.2 CCD Drive

The CCD sensor used in the machine is a 3-line (RGB, 1 line each) linear image sensor consisting of photocells of 7350 pixels. The signals photo-converted by the light-receiving block are sent out as analog signals of 2 channels (even-numbered pixels EVEN and odd-numbered pixels ODD).

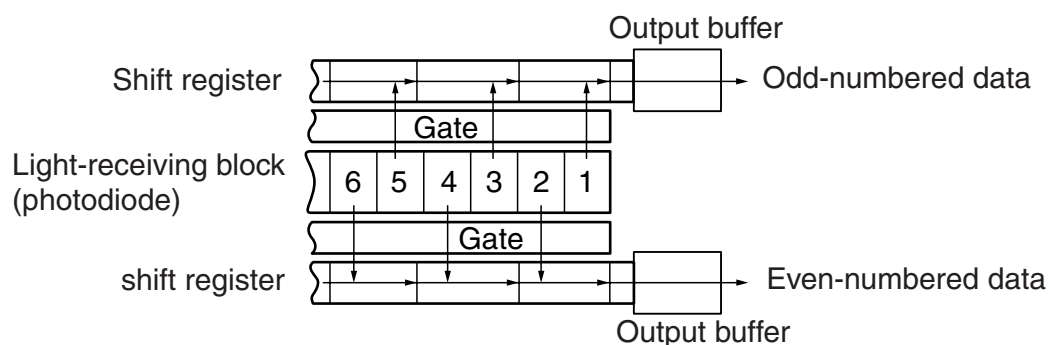

F02-202-01 CCD Block Diagram

2.3 CCD Output Gain Correction and Offset Correction

The analog video signals from the CCD are modified so that the rate of its amplitude is of a specific level (gain correction); it is also modified so that its output voltage in the absence of incident light is a specific level (offset correction).

2.4 A/D Conversion of CCD Output

The odd-numbered and even-numbered analog video signals after correction are further converted into 10-bit digital signals corresponding to the levels of the pixel voltages by the A/D converter.

3 Digital Image Processing

3.1 Outline

The machine uses the reader controller PCB for digital image processing; the major operations involved are as follows:

1. Shading Correction

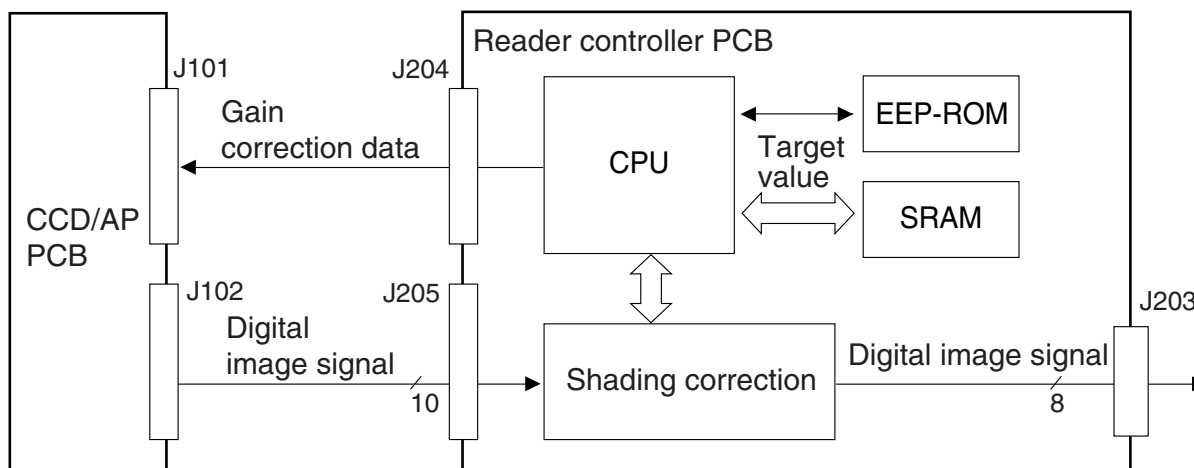

F02-301-01 Functional Block

3.2 Shading Correction

3.2.1 Outline

The output of the CCD is not necessarily uniform even when the density of the original is even for the following factors:

1. variation in sensitivity among pixels of the CCD
2. difference in transmission between the middle and the edge of the lens
3. difference in the intensity of light between the middle and the edges of the scanning lamp
4. deterioration of the scanning lamp

The machine executes shading correction so as to even out the discrepancies in CCD output. Shading correction may be shading adjustment, in which a target value is determined in service mode, or shading correction, in which a target value is determined for each scan of the original.

3.2.2 Shading Adjustment

In shading adjustment, the density of the standard white plate is measured, and the result is stored in memory as density data; the data is then computed to obtain the target value for shading correction.

3.2.3 Shading Correction

Shading correction is executed for each scan of the original. The density of the standard white plate is measured, and the shading correction circuit compares the result against the target value stored in memory in advance; the result of comparison is then used as the shading correction value to make up for the discrepancies among CCD pixels occurring at time of scans, thus ensuring uniform image density.

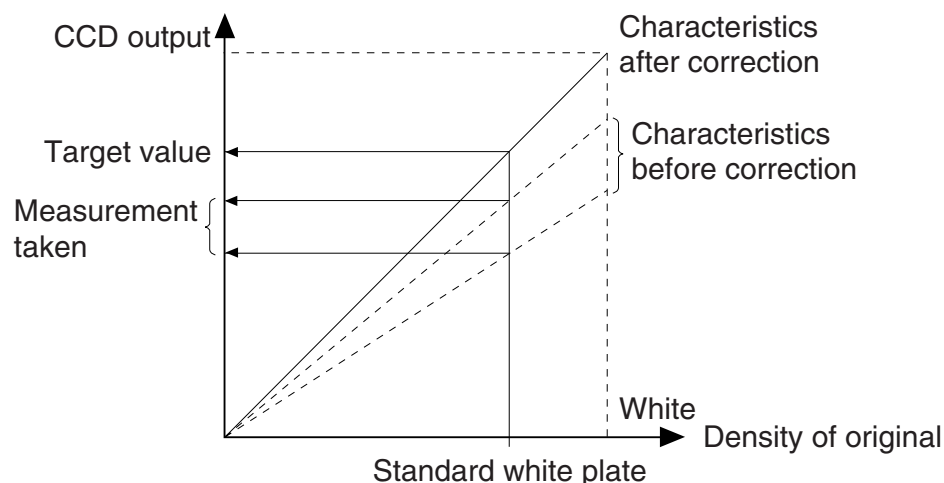

F02-302-01

CHAPTER 3

EXTERNALS AND CONTROLS

1 Power Supply

1.1 Timing of Power Supply

The reader unit is supplied with 24 VDC by the printer unit at the following timing of operation:

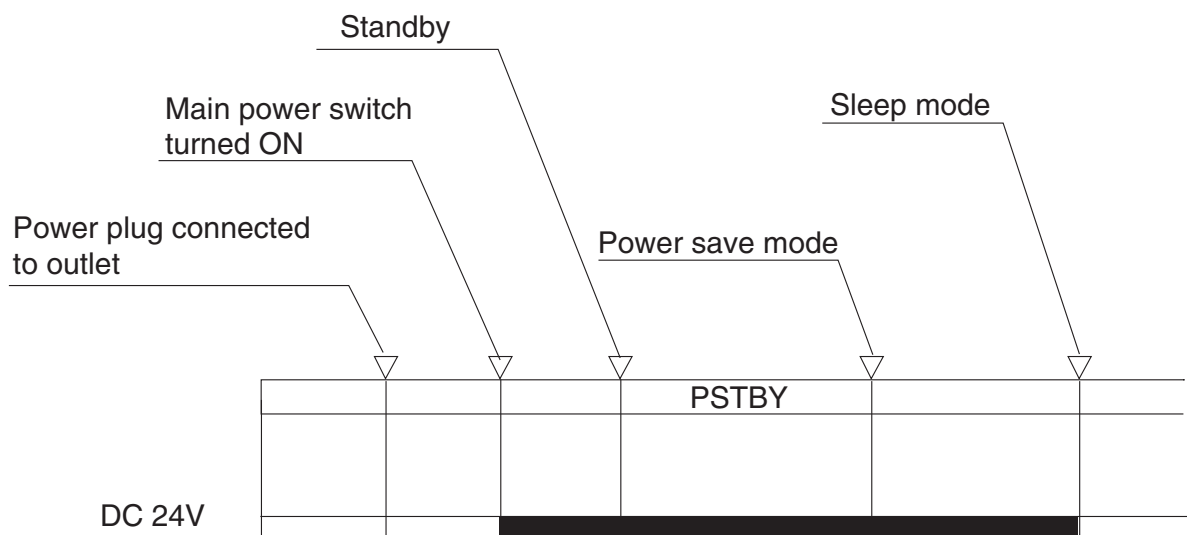

F03-101-01

1.2 Route of Power Supply

The machine uses the I/F PCB to produce the following types of DC voltage from the 24 VDC supplied by the printer unit:

- 5 VDC (for sensors)
- 3.3 VDC (for ICs)
- 2.5 VDC (for ICs)
- 15 VDC (for scanner motor drive)
- 24 VDC (for scanner motor drive)

The reader controller PCB produces the following type of DC voltage:

- 12 VDC (for CCD unit)

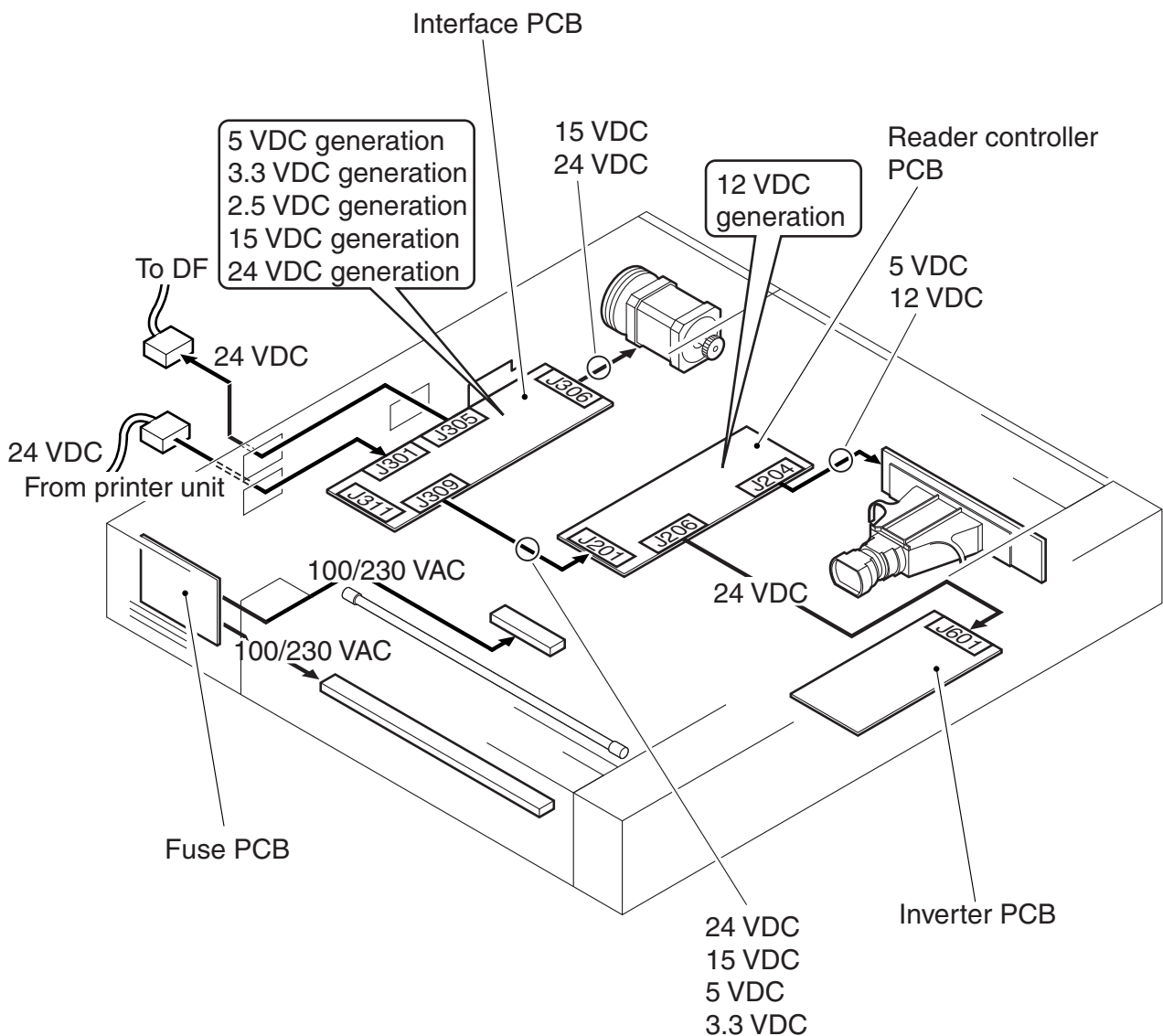

F03-101-02

Printer Unit

SERVICE MANUAL

CHAPTER 4 IMAGE FORMATION

1	Outline of Operation	4-1	2.8	SALT-Dhalf Control (development characteristics correction)	4-28
1.1	Specifications, Control Mechanisms, and Functions	4-1	2.9	Auto Gradation Control	4-30
1.2	Major Components of the Image Formation System	4-3	3	Drum Unit (D-UNIT)	4-32
1.3	Charging Specifications	4-4	3.1	Outline of the Drum Unit	4-32
1.4	Image Formation Process	4-6	3.2	Controlling the Drive of the Drum Unit (D-UNIT)	4-33
1.4.1	Image Formation Process (general)	4-6	3.3	Developing Assembly	4-34
1.4.2	Image Formation Process (image formation)	4-7	3.3.1	Construction of the Developing Assembly	4-34
1.4.3	Image Formation Process (transfer)	4-8	3.3.2	Controlling the Developing Bias	4-35
1.5	Basic Sequence of Operations ...	4-9	3.4	Auxiliary Brush	4-37
1.5.1	At Power-On (1)	4-9	3.4.1	Construction of the Auxiliary Brush	4-37
1.5.2	At Power-On (2)	4-10	3.4.2	Controlling the Auxiliary Bias	4-38
1.5.3	During Copying/Printing Operations (normal speed)	4-11	3.5	Charging Mechanism	4-42
1.5.4	Making Copies/Prints (half speed)	4-12	3.5.1	Construction of the Charging Mechanism	4-42
1.5.5	After Replacing the Drum Unit (D-UNIT)	4-13	3.5.2	Controlling the Charging Bias	4-43
1.5.6	Printing Originals Contain- ing a Color Page	4-14	4	Toner Container	4-45
1.6	Driving and Controlling the Image Formation System and the High-Voltage System	4-15	4.1	Outline of the Toner Container	4-45
2	Image Stabilization Control	4-17	4.2	Controlling the Toner Container Drive	4-46
2.1	Outline of Image Quality Control	4-17	4.3	Checking the Level of Toner	4-47
2.2	Automatic Image Stabilization Control	4-18	4.4	Controlling the Supply of Toner	4-49
2.3	ATR Control	4-21	5	Transfer Unit	4-50
2.4	Discharge Current Level Control	4-22	5.1	Outline of the Transfer Unit	4-50
2.5	ATVC Control (transfer bias level correction)	4-23	5.2	Controlling the Drive of the Transfer Unit	4-51
2.6	PASCAL Control (image gradation)	4-24	5.3	Controlling the Transfer Bias	4-52
2.7	SALT-Dmax Control (development characteristics correction)	4-26	5.4	Cleaning	4-54
			5.4.1	Intermediate Transfer Belt (ITB)	4-54
			5.4.2	Secondary External Roller	4-54
			5.4.3	Collecting Waste Toner	4-55

5.5 Separation	4-56	6.11 Removing the Auto Registration Sensor PCB	4-80
6 Disassembly and Assembly	4-58	6.12 Removing the Waste Toner Feedscrew	4-81
6.1 Removing the Intermediate Transfer Unit	4-58	6.13 Removing the Waste Toner Detection PCB	4-82
6.2 Removing the Intermediate Transfer Belt	4-60	6.14 Removing the Developer Motor (YMC)	4-86
6.3 Points to Note When Attaching the Intermediate Transfer Belt	4-64	6.15 Removing the Developer Motor (Bk)	4-87
6.4 Removing the Primary Transfer Roller	4-66	6.16 Removing the Toner Container Drive Unit	4-88
6.5 2 Removing the Secondary Transfer Internal Roller	4-68	6.17 Removing the Toner Container Motor	4-89
6.6 Removing the Drive Roller	4-70	6.18 Removing the Feedscrew Rotation Sensor	4-91
6.7 Removing the Secondary Transfer External Roller	4-72	6.19 Removing the Drum ITB Motor	4-93
6.8 Removing the Secondary Transfer Unit	4-74	6.20 Removing the Drum Drive Unit	4-96
6.9 Removing the Pattern Reader Unit	4-75	6.21 Removing the Transfer Cleaning Unit	4-97
6.10 Removing the SALT Sensor ...	4-78		

CHAPTER 5 PICKUP AND FEEDING

1 Outline of Operation	5-1	2 Detecting Jams	5-9
1.1 Specifications, Control Mechanisms, and Functions	5-1	2.1 Delivery Jam	5-9
1.2 Major Components	5-2	2.1.1 Delay Jam in the Cassette Pickup Assembly	5-9
1.2.1 Arrangement of the Units	5-2	2.1.2 Delay Jam Outside the Cassette Pickup Assembly	5-10
1.2.2 Arrangement of Rollers	5-3	2.2 Stationary Jams	5-11
1.2.3 Diagram of the Paper Paths	5-4	2.2.1 Common Stationary Jams	5-11
1.2.4 Arrangement of Sensors	5-5	2.2.2 Stationary Jams at Power-On	5-12
1.2.5 Arrangement of the Clutches and Solenoids	5-6	3 Cassette	5-13
1.2.6 Route of Drive	5-7	3.1 Identifying the Paper Size	5-13
1.3 Basic Sequence of Operations ...	5-8	3.2 Detecting the Level of Paper ...	5-15
1.3.1 Basic Sequence of Operations at Power-On	5-8	3.3 Cassette Pickup Unit	5-18
1.3.2 Basic Sequence of Operations in Response to a Press on the Start Key	5-8	3.3.1 Outline	5-18

3.3.2	Basci Sequence of Operations	5-19	8.6	Mounting the Sensor Mounting Plate	5-48
4	Manual Feed Pickup Unit	5-20	8.7	Removing the Pickup Vertical Path Cover Open/Closed Sensor	5-50
4.1	Ohtine	5-20	8.8	Removing the Cassette Retry Paper Sensor	5-51
4.2	Basic Sequence of Operations	5-22	8.9	Removing the Cassette Paper Sensor	5-52
4.3	Identifying the Size of Paper ...	5-23	8.10	Removing the Cassette Paper Level Sensor (A/B)	5-53
4.4	Detecting the Presence/Absence of Paper	5-24	8.11	Removing the Cassette Pickup Motor	5-54
4.5	Detecting the Last Paper	5-25	8.12	Removing the Cassette Pickup Solenoid	5-55
5	Registration Unit	5-26	8.13	Removing the Cassette Size Detecting Switch	5-56
5.1	Outline	5-26	8.14	Removing the Fixing/Feeder Unit	5-57
6	Duplex Unit	5-28	8.15	When Replacing the Fixing/Feeder Unit	5-57
6.1	Outline	5-28	8.16	Removing the Fixing/Feeder Unit Open/Closed Sensor	5-58
6.2	Controlling Horizontal Registration	5-29	8.17	Removing the Fixing/Feeder Unit Open/Closed Switch	5-59
6.3	Movemnt of Paper When Making Double-Sided Prints ...	5-30	8.18	Removing the Delivery Vertical Path Unit	5-61
6.3.1	Face-Down Delivery, A4, 5 Sheets in Circulation	5-30	8.19	Removing the Delivery Vertical Path Cover Open/Closed Sensor	5-63
6.3.2	Face-Down Delivery, A3, 3 Sheets in Cirucilation	5-34	8.20	Removing the Face-Down Delivery Sensor 1	5-64
7	Delivery	5-37	8.21	Removing the Face-Down Delivery Sensor 2	5-66
7.1	Switching Between Face-Up and Face-Down (using the FU/FD switching flapper)	5-38	8.22	Removing the Face-Down Delivery Roller 1	5-67
7.1.1	Movement in the Direction of Face-Down Delivery	5-38	8.23	Detaching the Face-Down Delivery Roller 1 Drive Belt ...	5-71
7.1.2	Movement in the Direction of Face-Up Delivery	5-39	8.24	Removing the Face-Down Delivery Motor	5-71
7.2	Switching Between Face-Down Center Tray Delivery and Copy Tray Delivery	5-40	8.25	Mounting the Face-Down Delivery Guide Sheet	5-72
7.2.1	Movement for Center Tray Delivery	5-40	8.26	Removing the Face-Up Delivery Roller	5-73
7.2.2	Movement for Copy Tray Delivery	5-41			
8	Disassembly and Assembly	5-42			
8.1	Removing the Pickup Unit	5-42			
8.2	Removing the Pickup Roller ...	5-44			
8.3	Removing the Feed Roller	5-44			
8.4	Removing the Separation Roller	5-45			
8.5	Removing the Vertical Path Roller	5-46			

8.27 Delivery Vertical Path Rollers 5-77	8.43 Removing the Internal Delivery Roller 5-107
8.27.1 Removing the Delivery Vertical Path Roller 1 5-77	8.44 Removing the Manual Feed Unit 5-108
8.27.2 Removing the Delivery Vertical Path Roller 2 5-78	8.45 Removing the Manual Feed Tray Unit 5-109
8.28 Delivery Vertical Path Heat Discharge Fan 5-79	8.46 Removing the Transparency Sensor (front/rear) 5-111
8.29 Removing the Delivery Vertical Path Motor 5-81	8.47 Removing the Registration Sensor 5-112
8.30 Removing the Center Delivery Tray Full Sensor 5-82	8.48 Removing the Manual Feed Roller 5-113
8.31 Removing the Delivery Path Switching Solenoid 1 5-82	8.49 Removing the Manual Feed Separation Roller 5-115
8.32 Removing the Delivery Path Switching Solenoid 2 5-84	8.50 Removing the Manual Feed Paper Sensor 5-118
8.33 Removing the Duplex Registration Clutch 5-85	8.51 Removing the Manual Feed Pickup Solenoid 5-119
8.34 Removing the Horizontal Registration Motor 5-88	8.52 Removing the Pre-Registration Motor 5-120
8.35 After Replacing the Horizontal Registration Motor 5-90	8.53 Removing the Registration Motor 5-121
8.36 Removing the Duplex Registration Sensor 5-91	8.54 Removing the Slide Resistor 5-122
8.37 After Replacing the Duplex Horizontal Registration Sensor 5-92	8.55 Removing the Manual Feed Last Paper Sensor 5-124
8.38 Removing the Duplex Pickup Clutch 5-93	8.56 Removing the Drawer Connector (fixing feeder unit) 5-126
8.39 Removing the Duplex Feeder Motor 5-96	8.57 Disconnecting the Drawer Connector (manual feed unit) 5-127
8.40 Removing the Duplex Registration Sensor 5-98	8.58 Adjusting the Horizontal Registration When Replacing the Pickup Cassette 5-128
8.41 Removing the Duplex Pickup Sensor 5-99	
8.42 Removing the Duplex Roller 1 5-102	

CHAPTER 6 FIXING

- 1 Outline of Operations 6-1
 - 1.1 Specifications, Control Mechanisms, and Functions 6-1
 - 1.2 Major Components 6-2
 - 1.3 Construction of the Control System 6-4
 - 1.4 Sequence of Operations (fixing system) 6-5
 - 1.4.1 Sequence of Operations at Power-On 6-5
 - 1.4.2 Sequence of Operations (printing; plain paper, for less than 180 sec) 6-6
 - 1.4.3 Basic Sequence of Operations (during printing; plain paper, for 180 sec or more) 6-7
- 2 Various Control 6-8
 - 2.1 Fixing Drive System 6-8
 - 2.1.1 Outline 6-8
 - 2.1.2 Controlling the Speed of the Fixing Roller 6-9
 - 2.2 Controlling the Fixing Roller Temperature 6-10
 - 2.2.1 Outline 6-10
 - 2.2.2 At Power-On 6-11
 - 2.2.3 In Standby 6-12
 - 2.2.4 During Printing 6-13
 - 2.2.5 Between Sheets 6-15
 - 2.2.6 Overheating in Areas Without Paper 6-16
 - 2.2.7 Return for Low-Power Mode 6-16
 - 2.3 Detecting the Passage of Paper 6-17
- 3 Protective Functions 6-18
 - 3.1 Turning Off the Power Against Overheating (in response to activation of thermal switch) ... 6-18
 - 3.2 Detecting Overheating by the Thermistors 6-19
- 4 Disassembly and Assembly 6-20
 - 4.1 Removing the Fixing Unit 6-20
 - 4.2 After Disassembling the Fixing Unit 6-21
 - 4.3 Removing the Delivery Upper Guide 6-23
 - 4.4 Removing the Fixing Inlet Guide 6-25
 - 4.5 Removing the Fixing Upper Frame 6-26
 - 4.6 Remove the Fixing Main Heater and the Fixing Sub Heater 6-30
 - 4.7 Removing the Fixing Roller 6-32
 - 4.8 Removing the Fixing Temperature Retainer Heater ... 6-34
 - 4.9 Removing the Pressure Roller 6-36
 - 4.10 Removing the Fixing Main Thermistor 6-37
 - 4.11 Removing the Fixing Sub Thermistor 6-38
 - 4.12 Removing the Fixing Thermal Switch 6-39
 - 4.13 Removing the Fixing Inlet Sensor 6-40
 - 4.14 Removing the Fixing Delivery Sensor 6-41
 - 4.15 Remove the Delivery Lower Guide 6-42

CHAPTER 7 EXTERNALS AND CONTROLS

1 Control Panel	7-1	5.4 Removing the Developing	
1.1 Outline	7-1	Drive Unit	7-18
1.2 Operations	7-2	5.5 Removing the Fixing Motor	7-20
1.2.1 LCD Processing	7-2	5.6 Remove the DC Power	
1.2.2 LCD Contrasts Adjustment	7-2	Supply Unit	7-21
1.2.3 Functions of the Control		5.7 Removing the Control Panel	7-22
Panel CPU	7-2	5.8 Removing the Control Panel	
2 Counters	7-3	Key PCB	7-23
2.1 Outline	7-3	5.9 Removing the Control Panel	
2.2 Incrementing the Counter		CPU PCB	7-24
Reading	7-4	5.10 Removing the Control Panel	
2.2.1 Signal-Sided Print and 2nd		Inverter PCB	7-25
Side of a Double-Sided		5.11 Removing the Control Panel	
Print	7-4	LCD Unit	7-26
2.2.2 1st Side of a Duplex Print		5.12 Removing the Main Power	
(duplex model only)	7-4	Supply Switch	7-27
3 Fans	7-5	5.13 Removing the Front Cover	
3.1 Outline	7-5	Open/Close Switch	7-28
3.2 Sequence of Operations (fans) ...	7-6	5.14 Removing the Front Cover	
4 Power Supply	7-7	Open/Closed Sensor	7-31
4.1 Outline	7-7	5.15 Removing the Manual Feed	
4.1.1 Wiring to Various		Unit Open/Closed Sensor	7-35
Accessories	7-7	5.16 Removing the Manual Feed	
4.1.2 Power Supply Route Inside		Unit Open/Close Switch	7-36
the Printer Unit	7-8	5.17 Removing the Manual Feed	
4.2 Rated Output of the DC		Cooling Fan	7-37
Power Supply PCB	7-10	5.18 Removing the Fixing Heat	
4.2.1 Rated Output of the		Exhaust Fan	7-38
Machine Power Supply	7-10	5.19 Removing the Heat Discharge	
4.2.2 Rated Output of the		Fan Unit	7-39
Pedestal DC Power		5.20 Removing the Heat Discharge	
Supply	7-10	Fan	7-40
4.3 Protective Mechanisms	7-10	5.21 Removing the DC Controller	
4.4 Backup Power Supply	7-11	PCB	7-41
4.5 Power Save Functions	7-12	5.21.1 When Replacing the DC	
4.5.1 Outline	7-12	Controller PCB	7-43
5 Disassembly and Assembly	7-14	5.22 Removing the Delivery	
5.1 Removing the Fixing Drive		Cooling Fan	7-44
Unit	7-14	5.23 Removing the Cleaner Fan	7-45
5.2 Removing the High-Voltage		5.24 Removing the Power Supply	
Unit	7-15	Cooling Fan	7-46
5.3 Removing the Secondary		5.25 Removing the Leakage	
Transfer High-Voltage Unit	7-16	Breaker	7-47

CONTENTS

5.26 Removing the Relay PCB 1	7-49	5.29 Removing the Fuse PCB	7-55
5.27 Removing the Duplex Driver PCB	7-53	5.30 Removing the Drum Unit Drive Belt	7-56
5.28 Removing the Counter Memory PCB	7-54	5.31 Removing the Environment Sensor	7-58

CHAPTER 1

INTRODUCTION

1 Product Specifications

Method of exposure	Laser	
Method of charging	Roller	
Method of development	Monochrome	Dry, 2-component
	Color	Dry, 2-component
Toner	Monochrome	Non-magnetic, negative toner (S toner)
	Color	Non-magnetic, negative toner (S toner)
Supply of toner	Monochrome	Toner container
	Color	Toner container
Detection of toner level	Yes	
Photosensitive material (drum)	Material	OPC
	Diameter	30.6 mm
	Quantity	4 drums
Drum cleaning	No	
Method of transfer	Intermediate transfer belt	
	Primary transfer: charging roller	
	Secondary transfer: charging roller	
Method of separation	Curvature (static eliminator)	
Method of transfer cleaning	Blade	
Method of pickup	Cassette	550 sheets (80 g paper) × 2
	Manual feed tray	100 sheets (80 g paper)
	Roll paper	No
	2-Cassette Pedestal-X1	550 sheets × 2
	Side paper deck-P1	2,700 sheets (80 g paper)
Type of delivery	Type	Face-up (extension tray)
		Face-down (w/o tray: internal; w/ tray: option)
	Reversal delivery	Standard with machine (face-down delivery path present)
Type of duplexing		Through-path
Method of fixing	Fixing roller	
Control panel	Recording paper level indicator	3-level indication + Add Paper message
Dimensions	Width (W)	620 mm
	Depth (D)	740 mm
	Height (H)	712 mm
Weight	105.5 kg	(including duplexing unit; not including toner container, drum unit, cable)

T01-100-01

Specifications subject to change for product improvement.

CHAPTER 2

BASIC OPERATIONS (AS A PRINTER)

1 Functional Construction

The machine can roughly be divided into the following functional blocks:

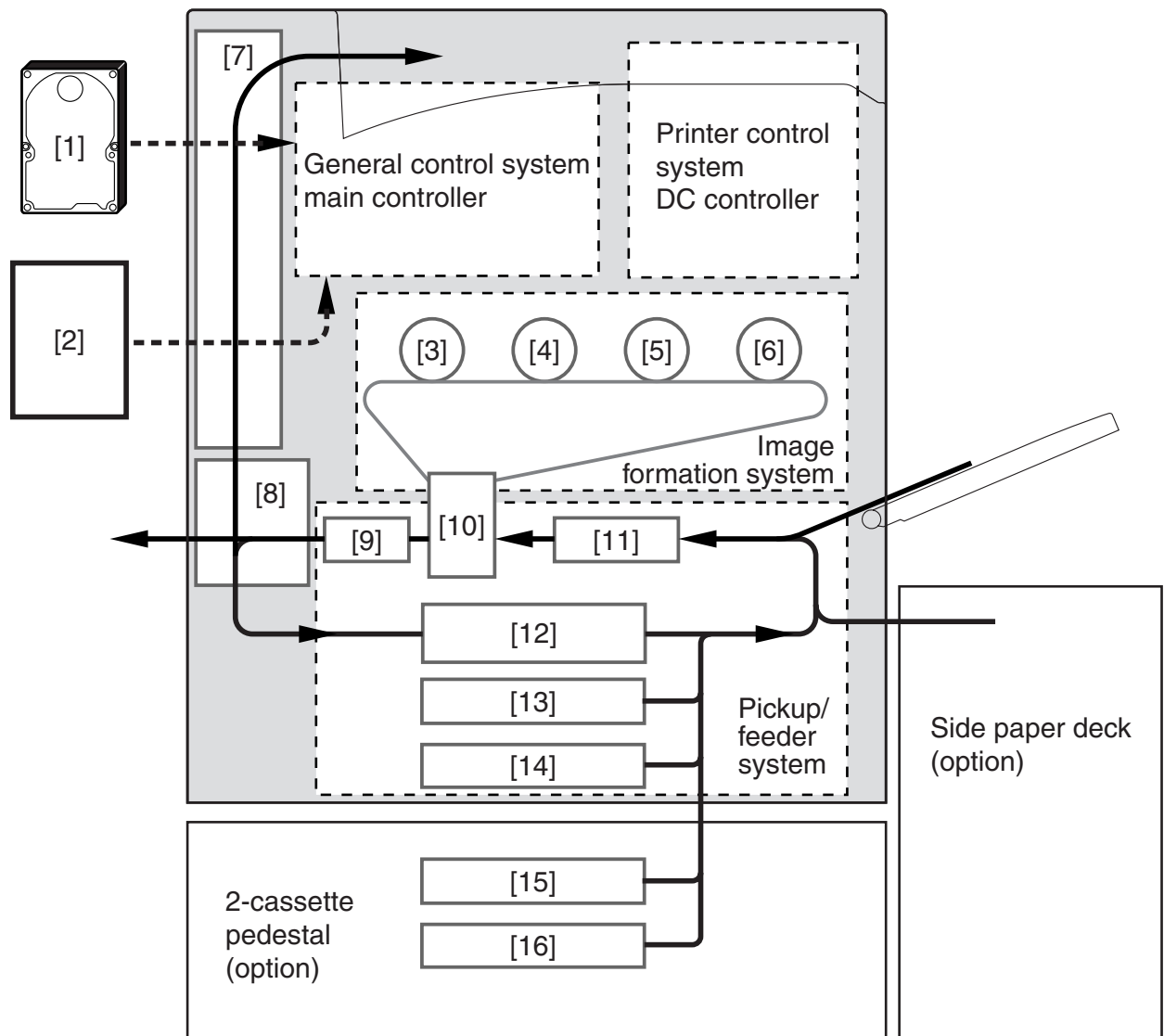

- | | |
|------------------------------|----------------------|
| [1] HDD | [9] Feeding system |
| [2] Option boards | [10] Transfer system |
| [3] Photosensitive drum (Y) | [11] Pickup control |
| [4] Photosensitive drum (M) | [12] Duplex/feeder |
| [5] Photosensitive drum (C) | [13] Cassette 1 |
| [6] Photosensitive drum (Bk) | [14] Cassette 2 |
| [7] Delivery system | [15] Cassette 3 |
| [8] Fixing system | [16] Cassette 4 |

F02-100-01

2 Arrangement of Major PCBs

The machine's major PCBs are wired as follows:

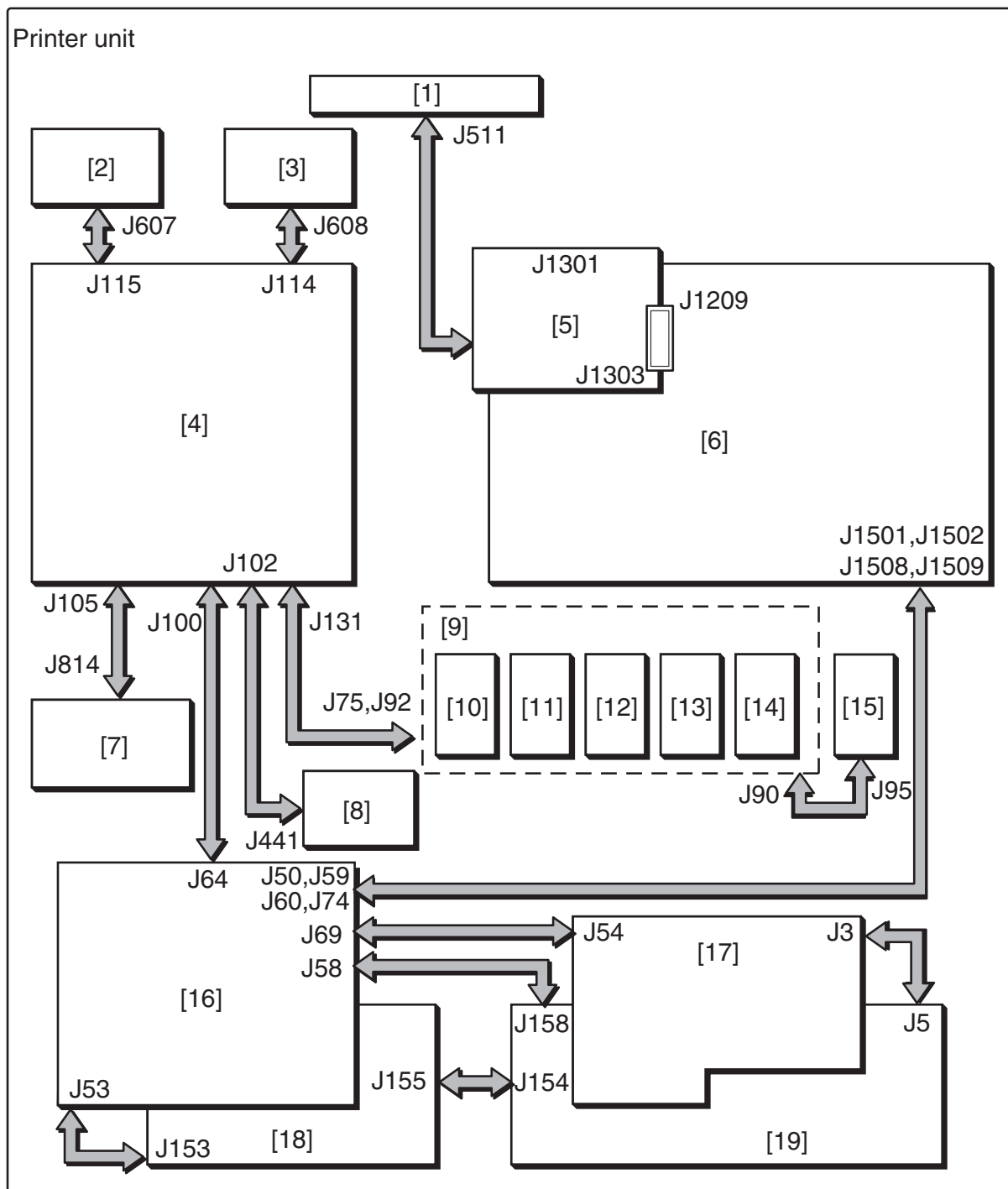

↔ flat cable.

▭ PCB-to-PCB connector.

F02-200-01

- | | |
|--------------------------------|------------------------------|
| [1] Control panel CPU PCB | [11] HV1-SUB PCB |
| [2] BD detection PCB | [12] HV2 PCB |
| [3] Laser driver PCB | [13] HV2-SBU PCB |
| [4] DC controller PCB | [14] HV4 PCB |
| [5] Main controller PCB (sub) | [15] HV3 PCB |
| [6] Main controller PCB (main) | [16] Fuse PCB |
| [7] Drum ITB motor | [17] Heater control PCB |
| [8] Duplex driver PCB | [18] DC power supply PCB (1) |
| [9] High-voltage unit | [19] DC power supply PCB (2) |
| [10] HV1 PCB | |

T02-200-01



The symbol \Leftrightarrow used in the diagram indicates connection of PCBs, and does NOT indicate the direction of signals.

The major PCBs of the machine's main controller are connected as follows:

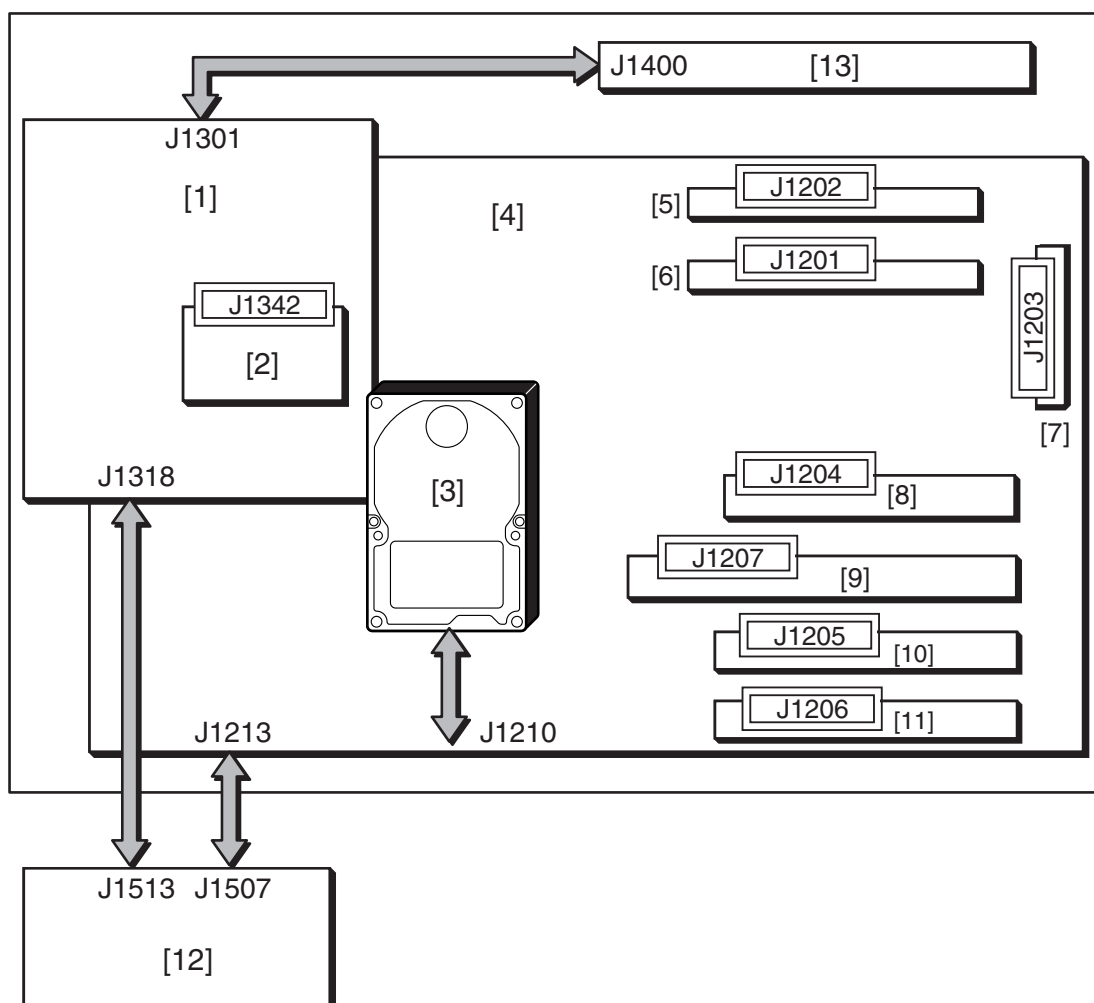

- | | |
|--------------------------------|---|
| [1] Main controller PCB (sub) | [8] Ethernet board |
| [2] SRAM PCB | [9] UFR board or Open interface board |
| [3] HDD | [10] USB interface board or TokenRing board |
| [4] Main controller PCB (main) | [11] Image conversion board |
| [5] 512-MB expansion RAM | [12] Power distribution PCB |
| [6] 256-MB expansion RAM | [13] Differential PCB |
| [7] Boot ROM | |

F02-200-02



The symbol \Leftrightarrow used in the diagram indicates connection of PCBs, and does NOT indicate the direction of signals.

2.1 DC Controller PCB

The following is a functional diagram of the DC controller PCB:

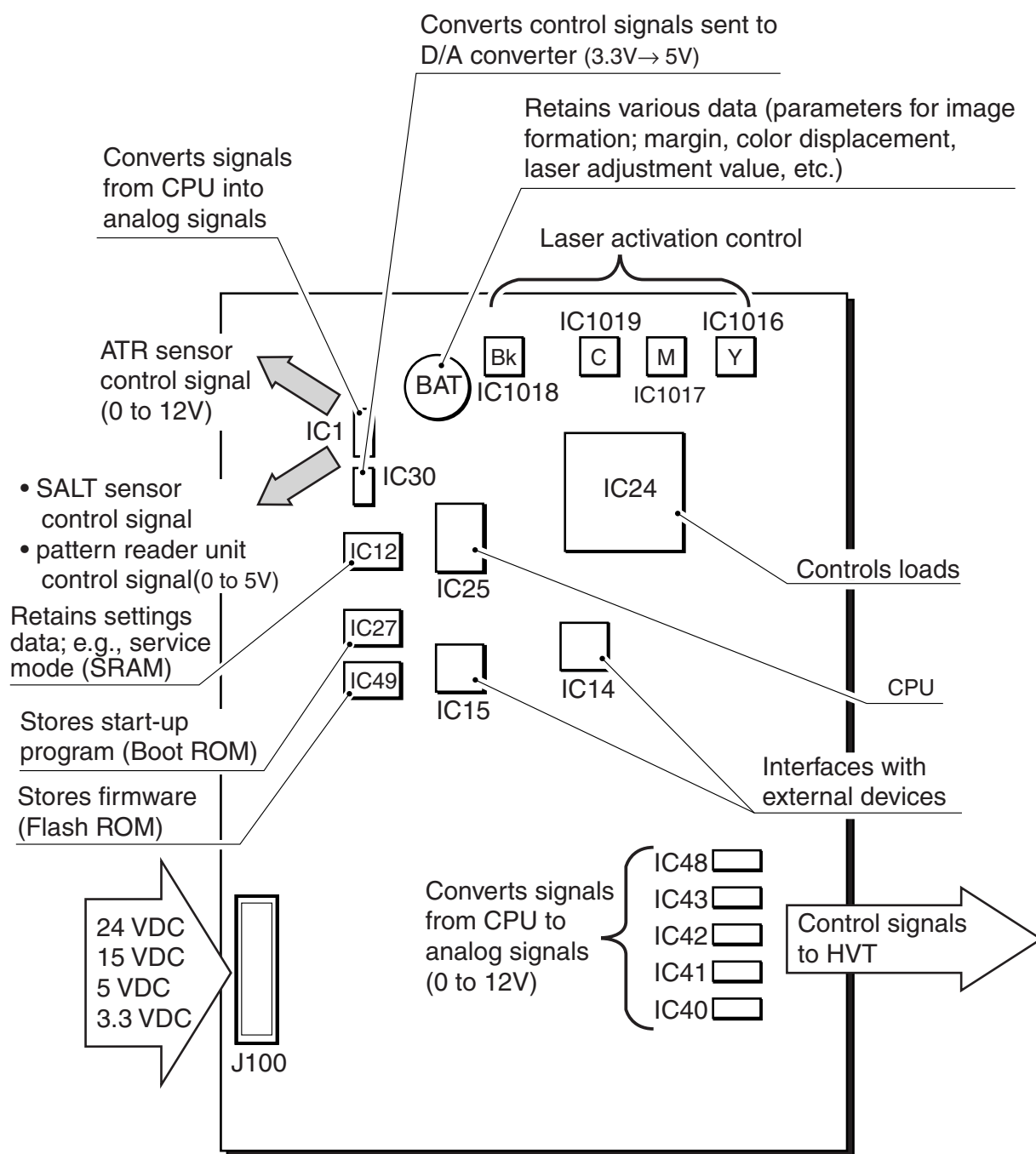

F02-201-01

3 Basic Sequence of Operations

3.1 Basic Sequence of Operations

Period	Description
WMUP (warm-up)	While the drive system is at rest and, in addition, until the surface temperature of the fixing roller reaches 90°C.
WMUPR (warm-up rotation)	After the drive system starts up and, in addition, bias adjustment is under way.
PSTBY (printer standby)	While the machine is ready for a copy/print request signal.

T02-301-01

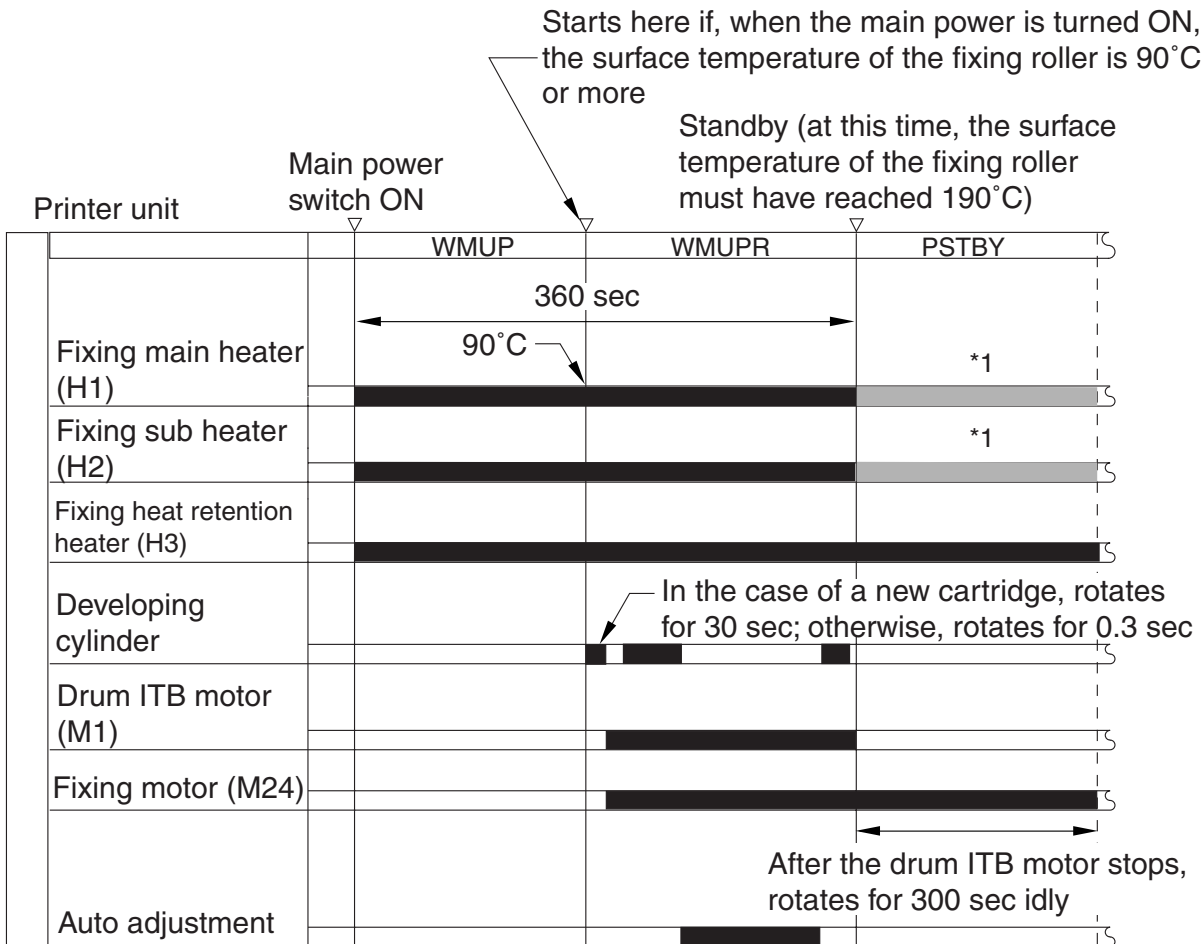

F02-301-01

3.2 Basic Sequence of Operations

a. Full-Color

full-color, A4, 2 copies continuous, 100%, cassette 1

Period	Description
PSTBY (print standby)	While the machine is ready to accept a copy/print request signal.
PINTR (printer initial rotation)	From when a print request signal is received until an image signal is sent.
PRINT	Until all toner is transferred to paper and the paper is delivered.
LSTR (last rotation)	From when paper is delivered until all drive stops.

T02-302-01

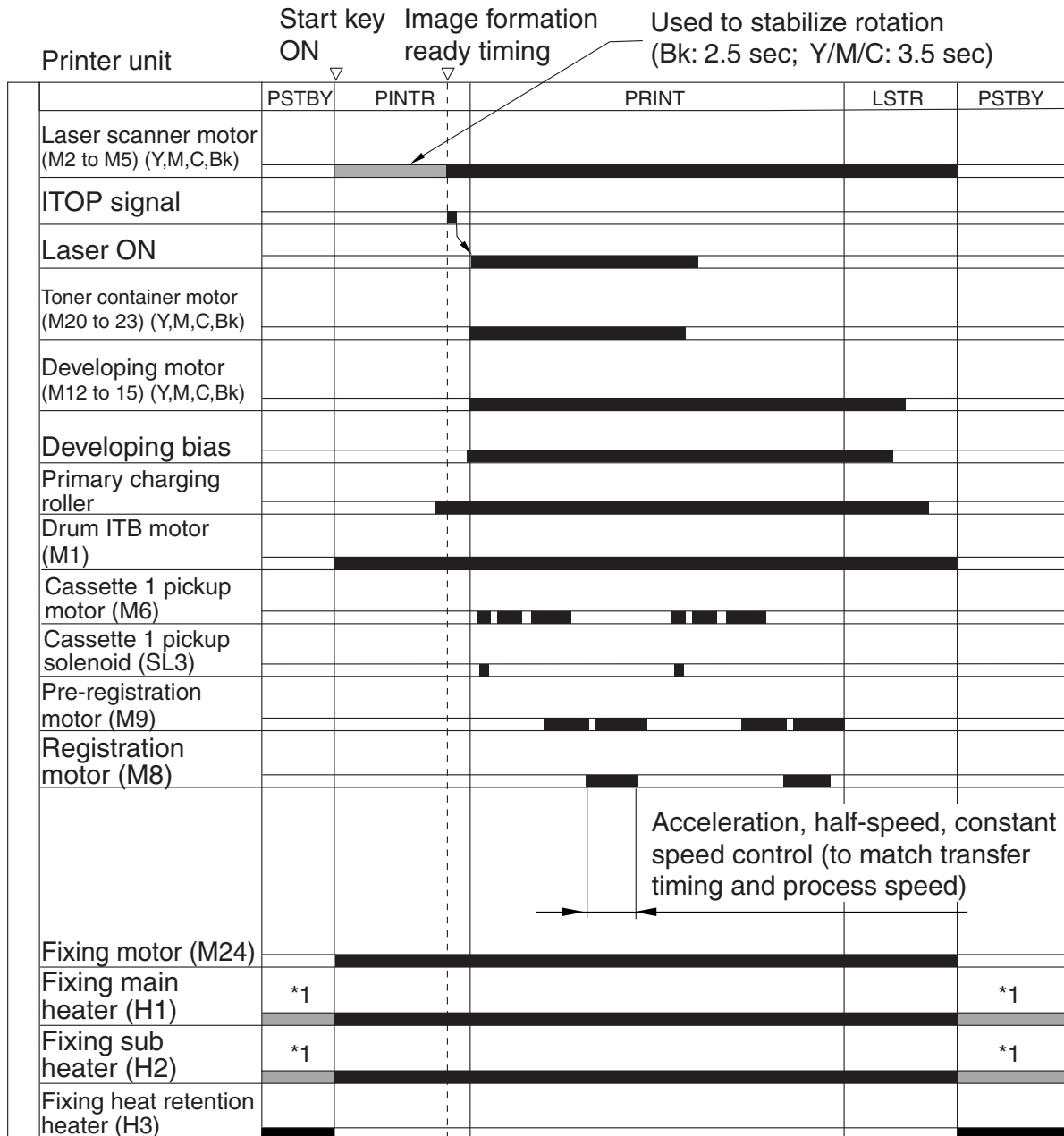

*1: The machine executes temperature control using the main heater or the sub heater according to the difference in the readings of temperature between the main thermistor (TH1) and the sub thermistor (TH2). (controlled to 190°C)

F02-302-01

b. Monochrome

monochrome, A4, 2 copies continuous, 100%, cassette 1

Period	Description
PSTBY (print standby)	While the machine is ready to receive a copy/print request signal.
PINTR (printer initial rotation)	From when a print request signal is received until the image signal is sent.
PRINT	Until all toner is transferred to the paper and the paper is delivered.
LSTR (last rotation)	From when paper is delivered until all drive stops.

T02-302-02

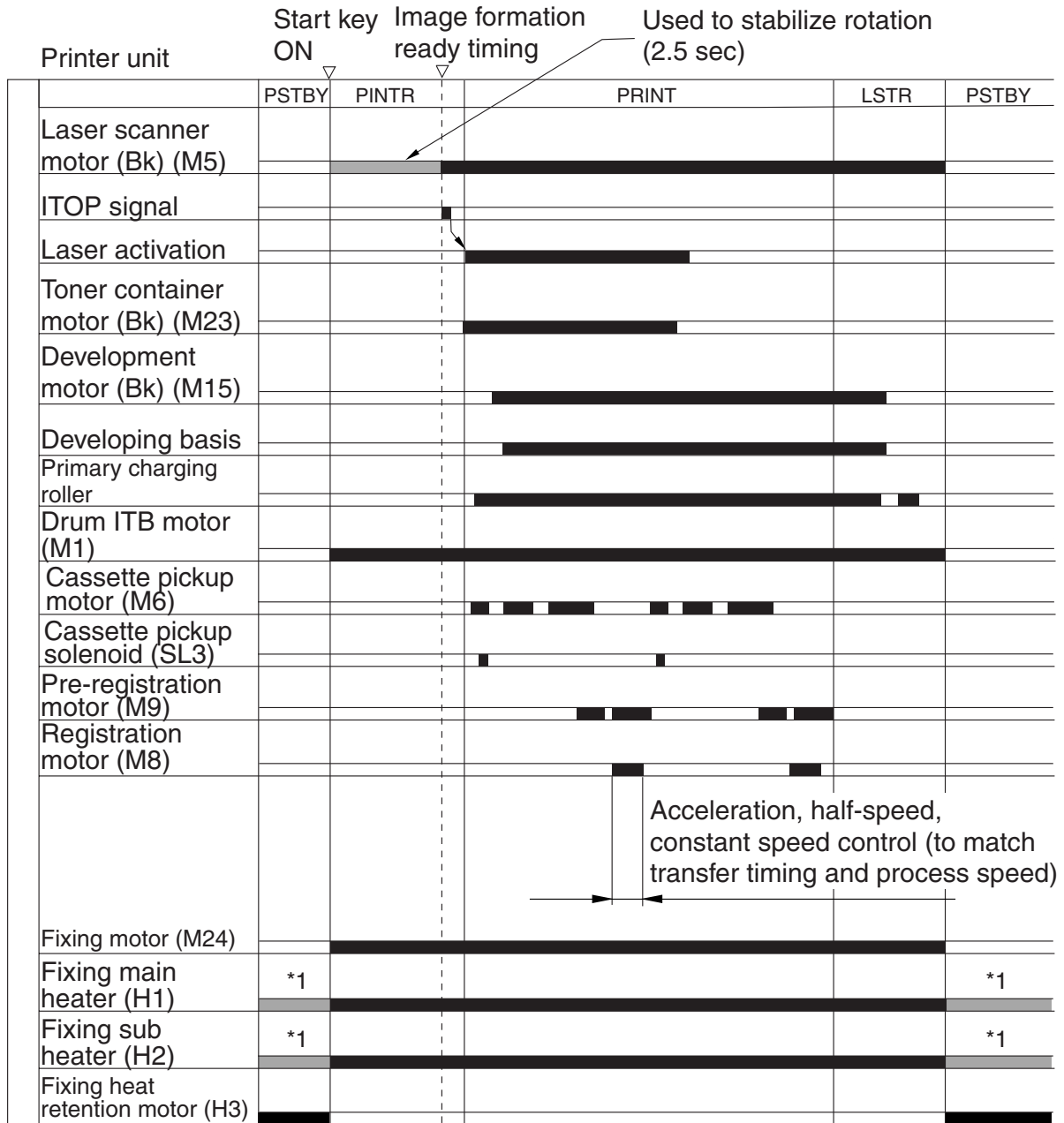

*1: The machine uses the main heater or the sub heater for temperature control according to the difference in the readings of temperature between the main thermistor (TH1) and the sub thermistor (TH2). (controlled to 90°C)

F02-302-02

CHAPTER 3

LASER EXPOSURE

1 Outline of Operations

1.1 Specifications, Control Mechanisms, and Functions

Laser light

Wave length	780 nm (infrared)
Output	5 mW
Number of laser beams	2

Scanner motor

Type of motor	DC brush-less
Number of revolutions	23000 rpm (approx.)
Type of bearing	Oil

Polygon mirror

Number of facets	4 facets (20 mm)
------------------	------------------

Control mechanisms

Sync control	main scanning direction sub scanning direction
Light intensity	APC control PWM control
Color displacement correction	reproduction ratio in main scanning direction displacement in main scanning direction
Others	scanner motor control laser shutter control laser ON/OFF control

1.2 Major Components

Name	Description
Laser driver	generates laser light.
Polygon mirror	scans the laser beam in main scanning direction.
Guide mirror	directs laser light in the direction of the drum.
Corrective lens	corrects displacement of laser light coming from the guide mirror in main scanning direction.
Displacement correction motor	moves the corrective lens to correct displacement in main scanning direction.
BD detection PCB	detects laser light as a BD signal.
BD mirror	reflects the laser light in the direction of the BD detection PCB.

T04-102-01

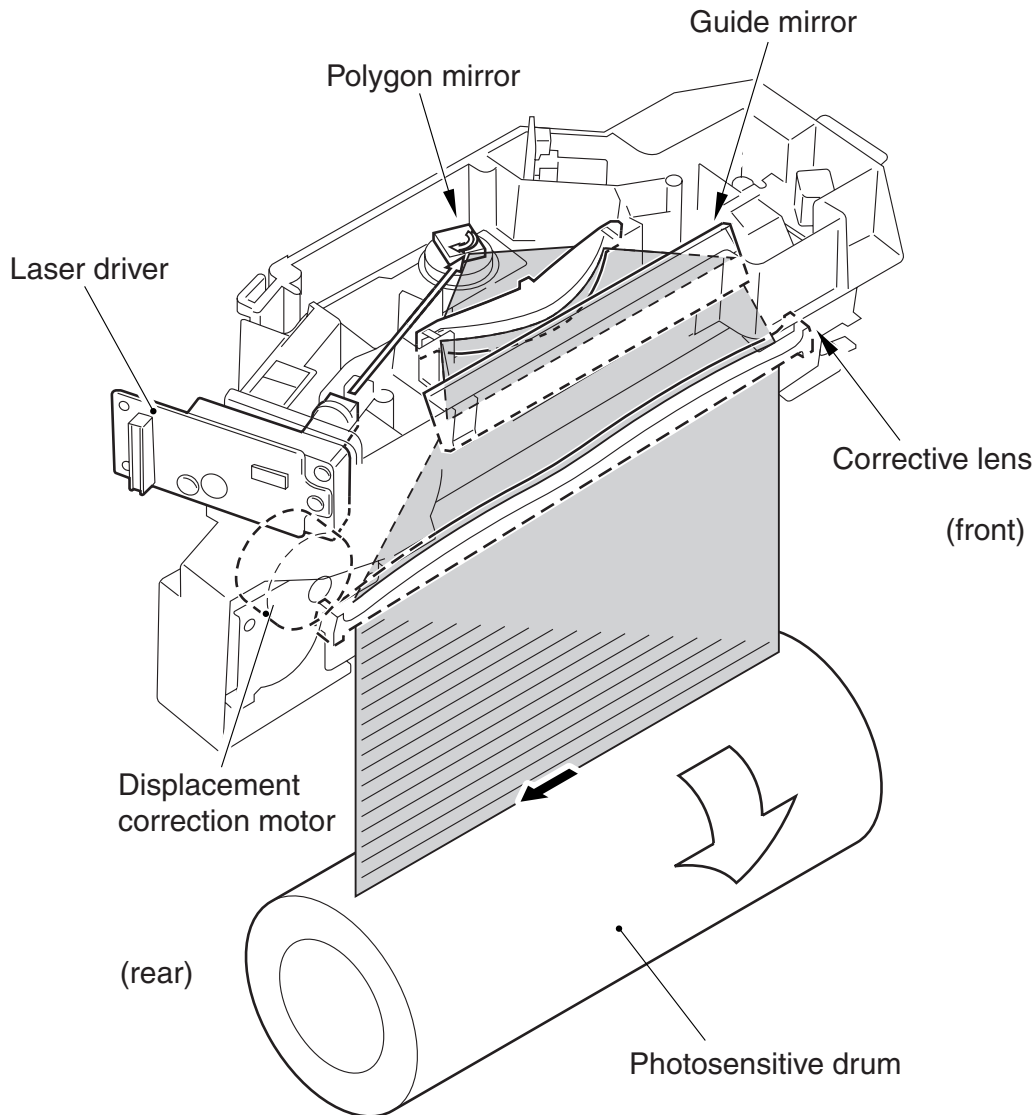

F03-102-01

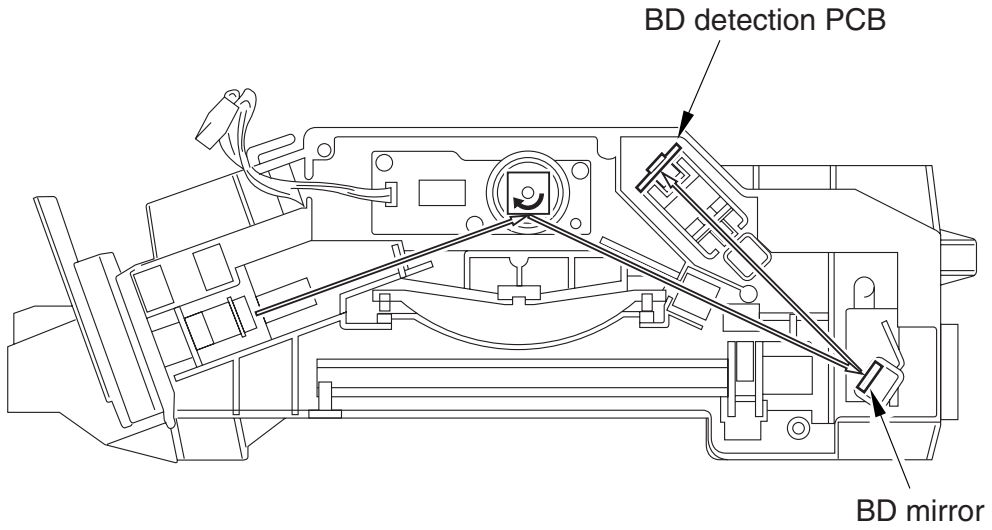

F03-102-02

1.3 Construction of the Control System

The laser exposure system is controlled mainly by the DC controller PCB.

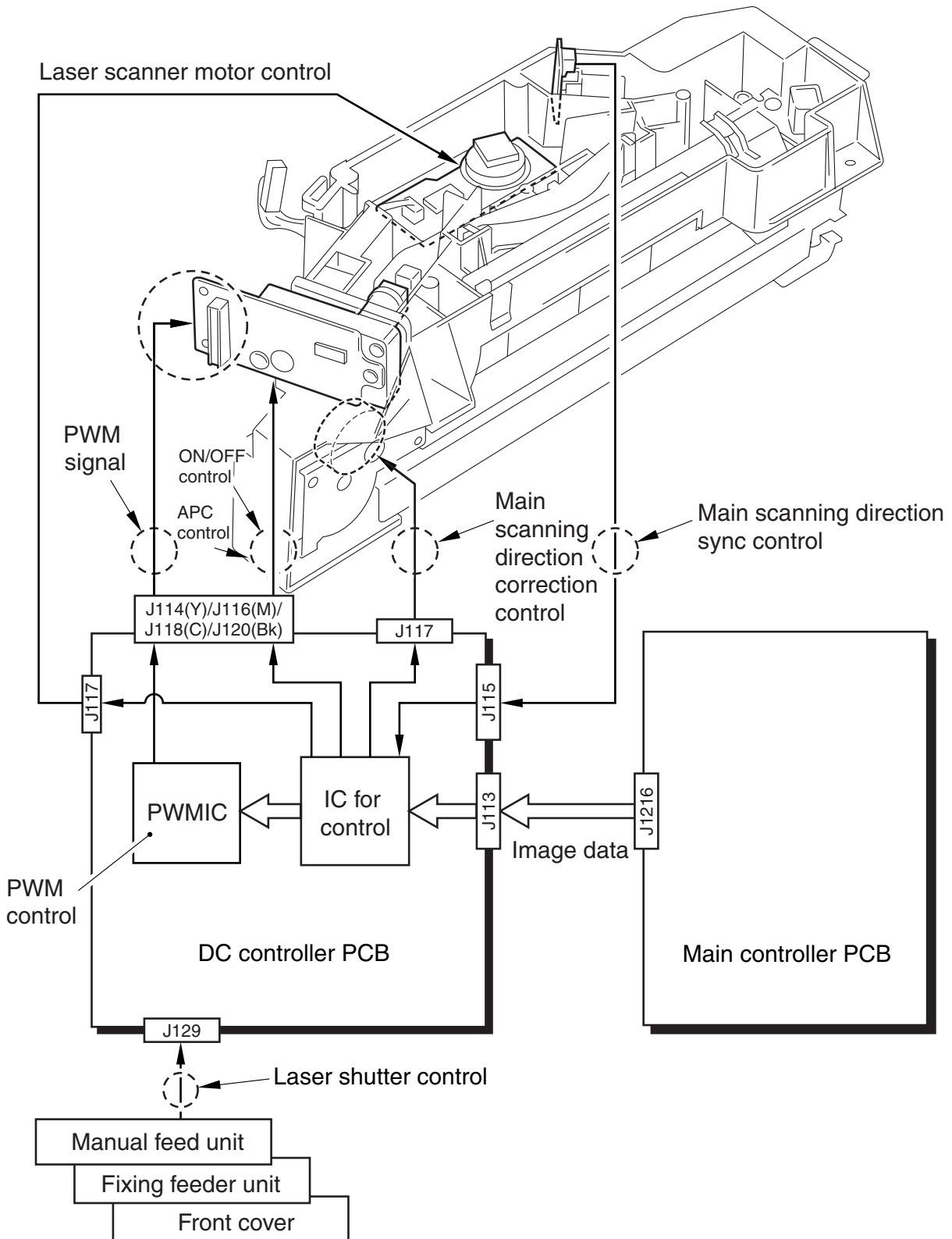

F03-103-01

1.4 Basic Sequence of Operations

The laser scanner motor starts to rotate when the Start key is pressed (or the print request signal is issued). When its rotation has stabilized, the printer unit becomes ready for formation of images, causing the printer side to generate the sync signal (PTOP).

The machine uses the signal to generate the sub scanning direction signals (Y-TOP, M-TOP, C-TOP, K-TOP) for individual colors, and turns on the lasers of the corresponding colors.

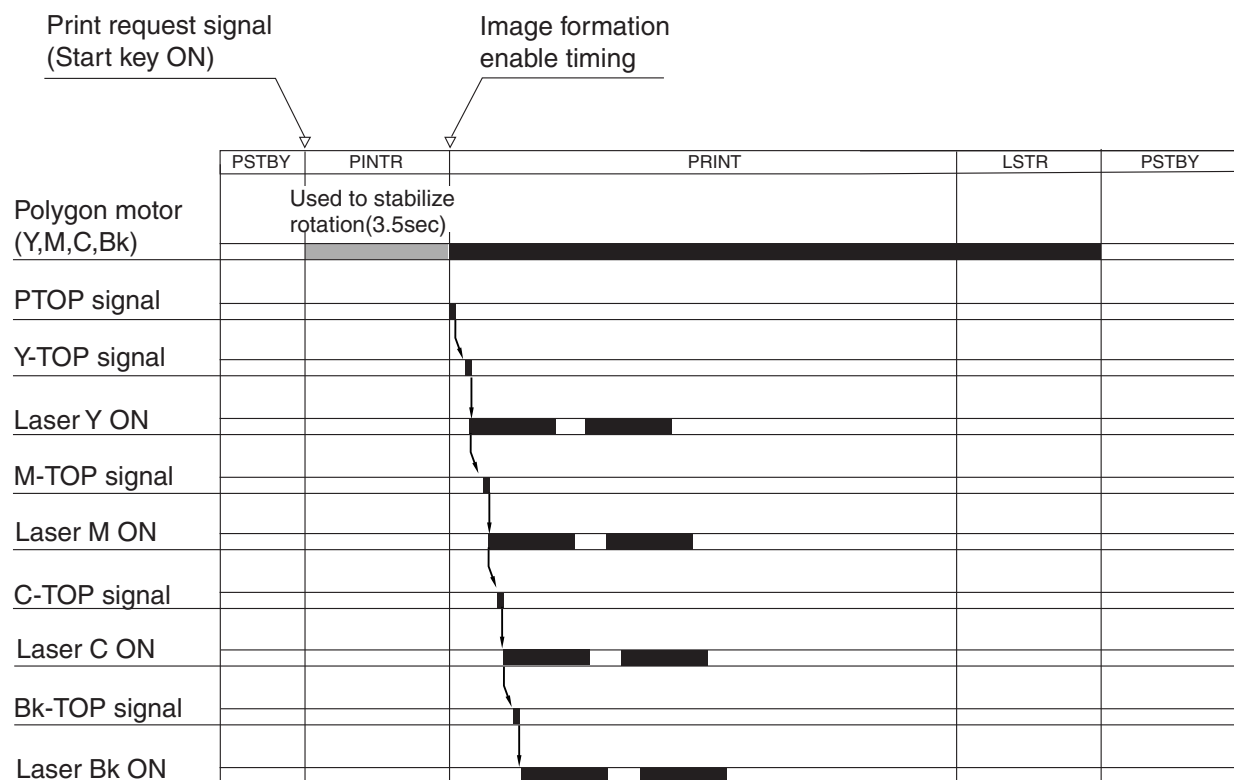

F03-104-01

2 Various Control Mechanisms

2.1 Controlling the Laser Activation Timing

2.1.1 Turning On/Off the Laser

The laser light is turned on/off in keeping with combinations of control signals (TRL0/1/2) from the DC controller PCB.

CTRL2	CTRL1	CTRL0	Status of laser A	Status of laser B
0	0	0	OFF	OFF
0	0	1	OFF (bias current applied)	APC control
0	1	0	APC control	OIFF (bias current applied)
0	1	1	OFF (bias current applied)	OFF (bias current applied)
1	0	0	ON (for factory adjustment)	ON (for factory adjustment)
1	0	1	OFF (bias current applied)	ON (for factory adjustment)
1	1	0	ON (for factory adjustment)	OFF (bias current applied)
1	1	1	ON (for image formation)	ON (for image formation)

T03-201-01

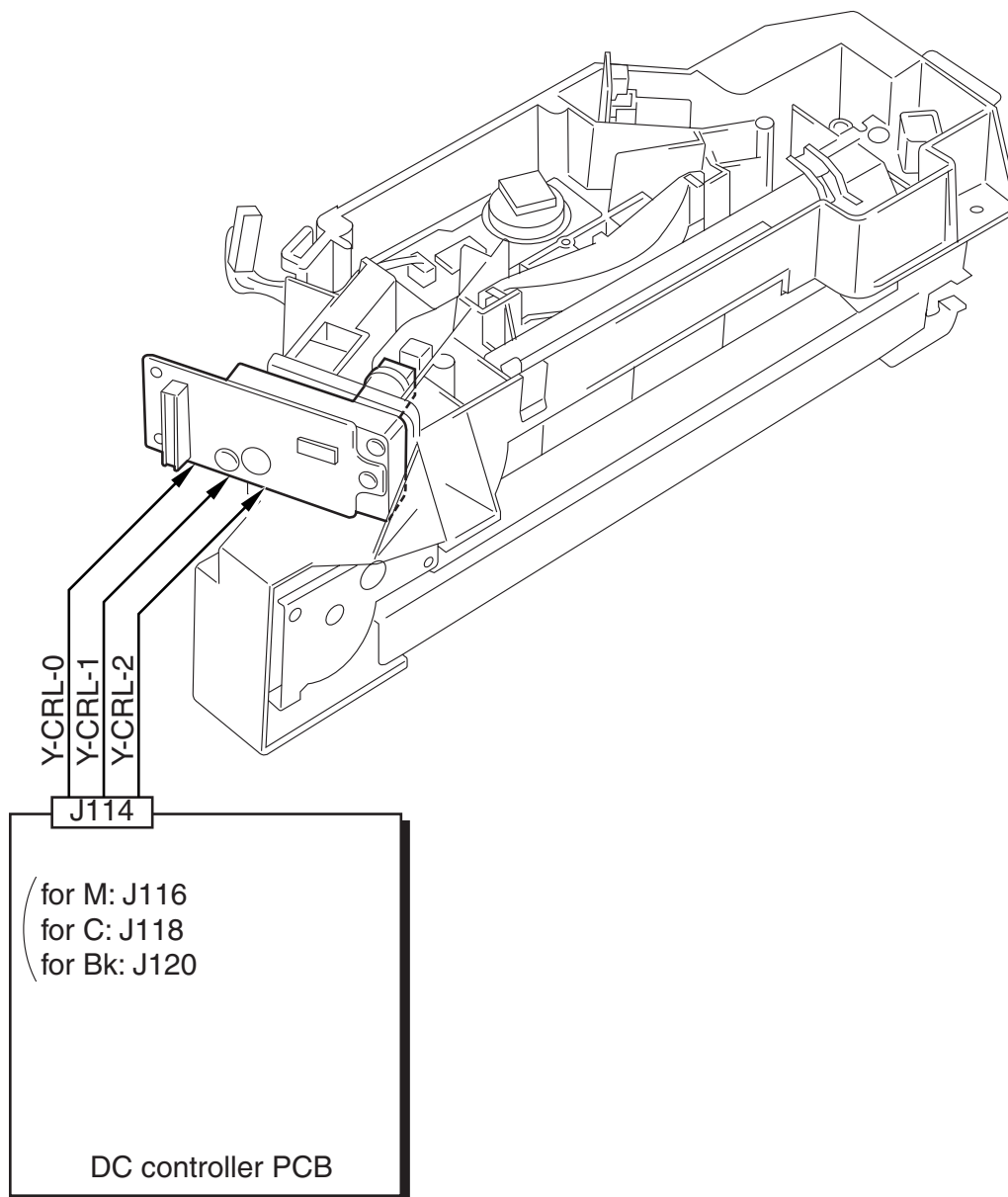

F03-201-01

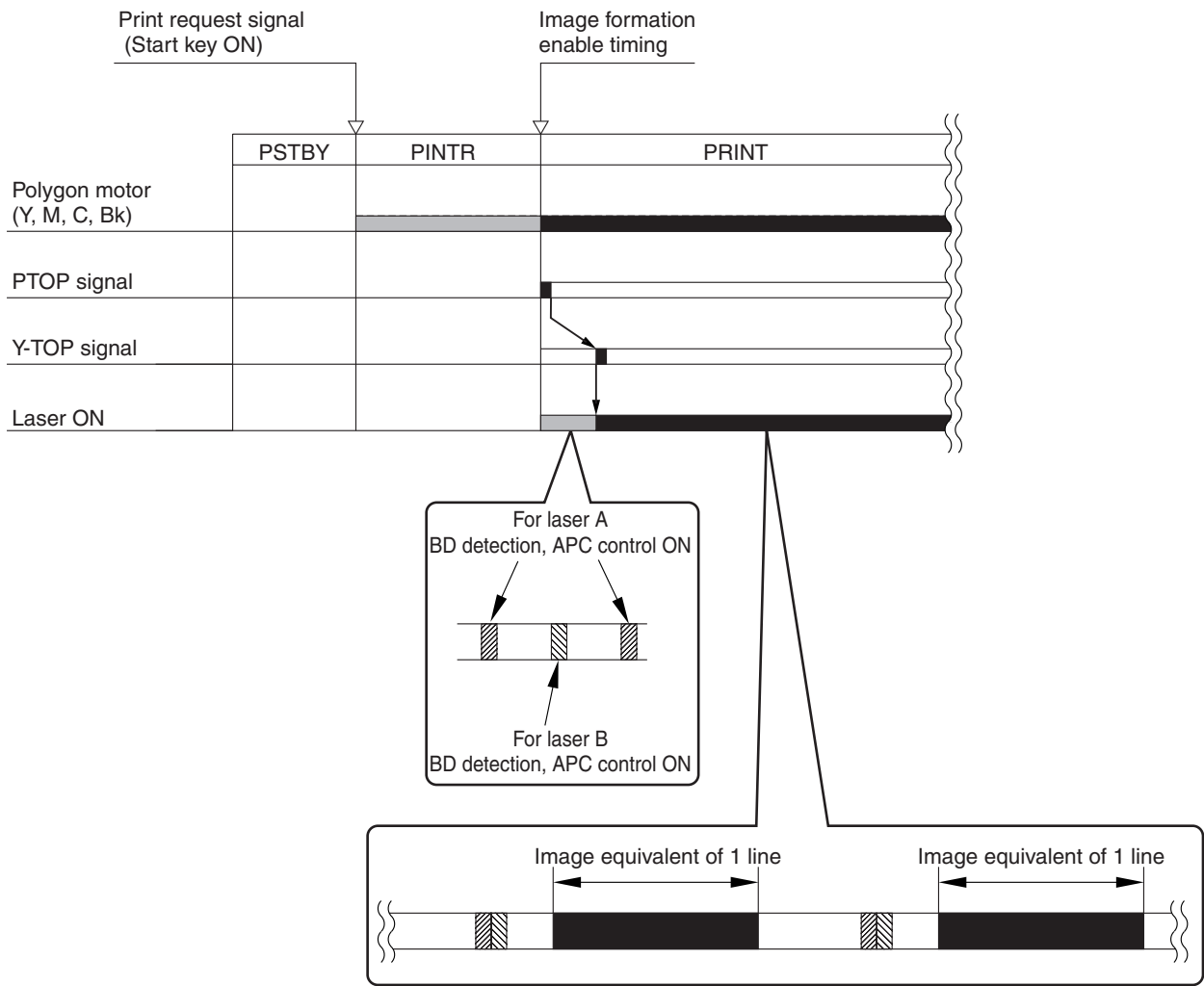

F03-201-02

2.1.2 BD Signal

- The machine is equipped with a laser unit that can generate 2 channels of laser light (A and B).
- These 2 channels of laser light are based on separate BD signals.

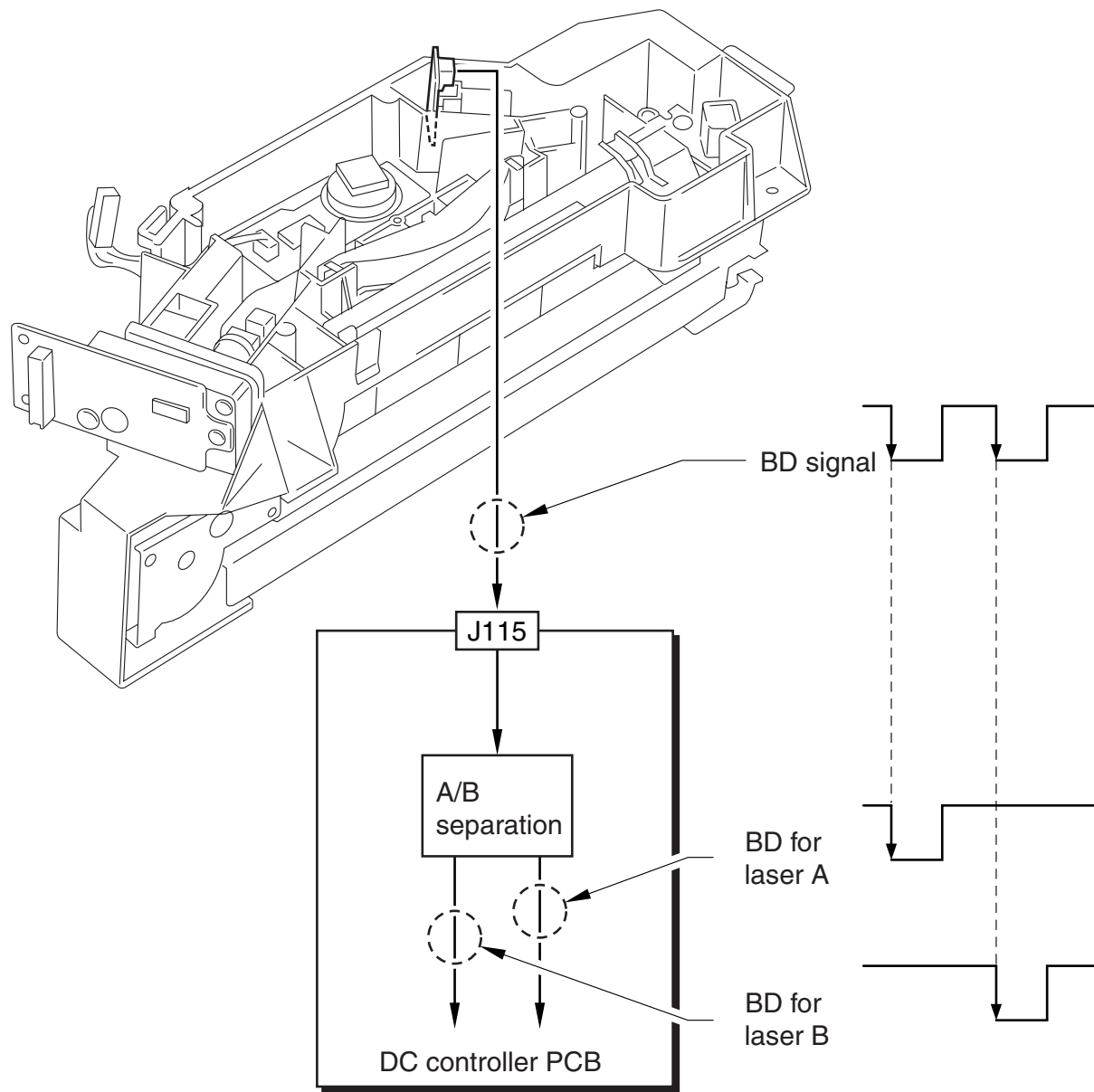

F02-201-03

2.1.3 Controlling Synchronization in Main Scanning Direction

The control of synchronization in main scanning direction is based on the BD signal.

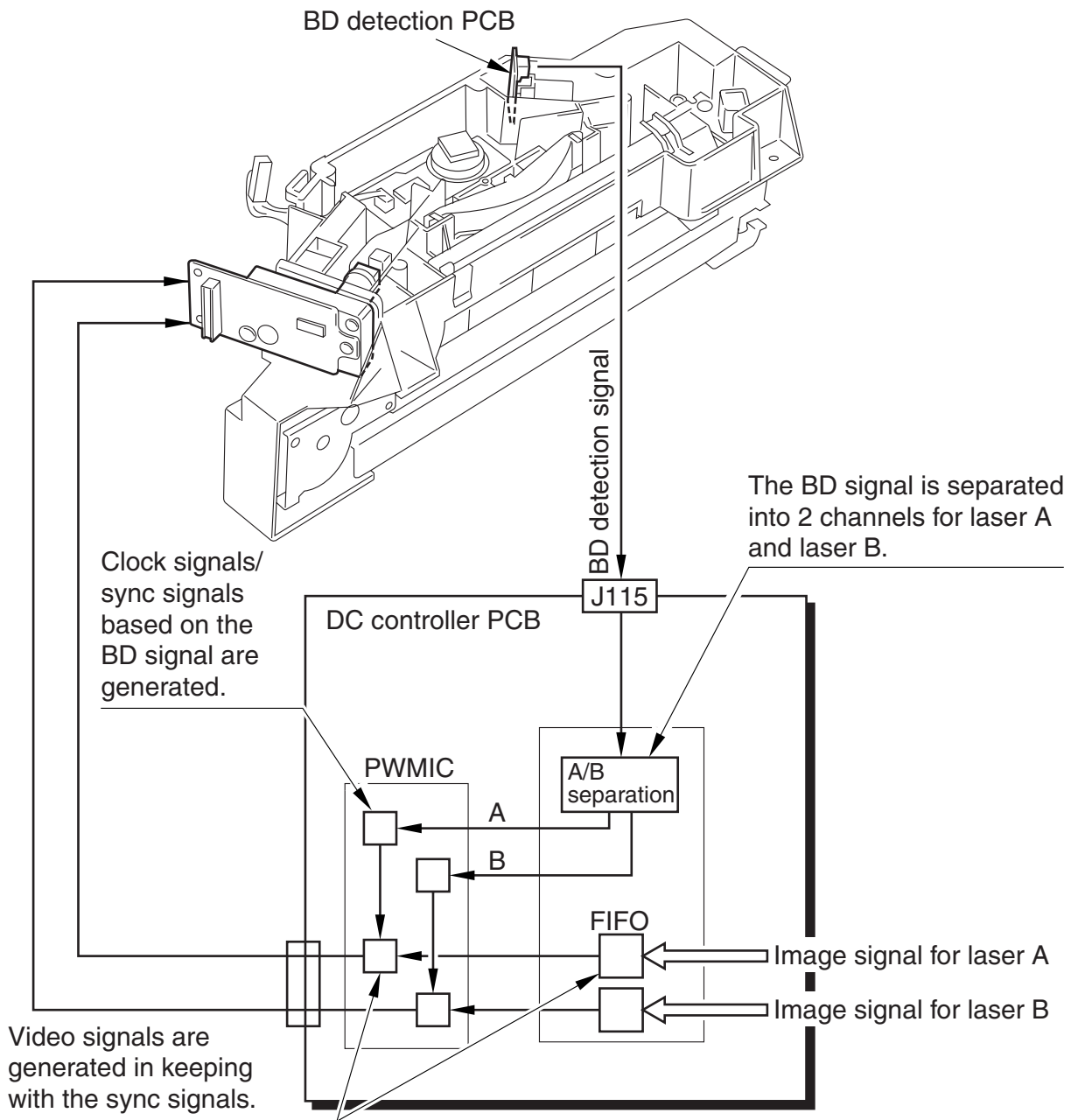

F03-201-04

2.1.4 Controlling Synchronization in Sub Scanning Direction

- The synchronization in sub scanning direction is controlled with reference to the PTOPI signal (image formation start signal).
- When the mechanism becomes ready for image formation, the PTOPI signal (image formation start signal) is generated, turning on the individual lasers based on the signal.

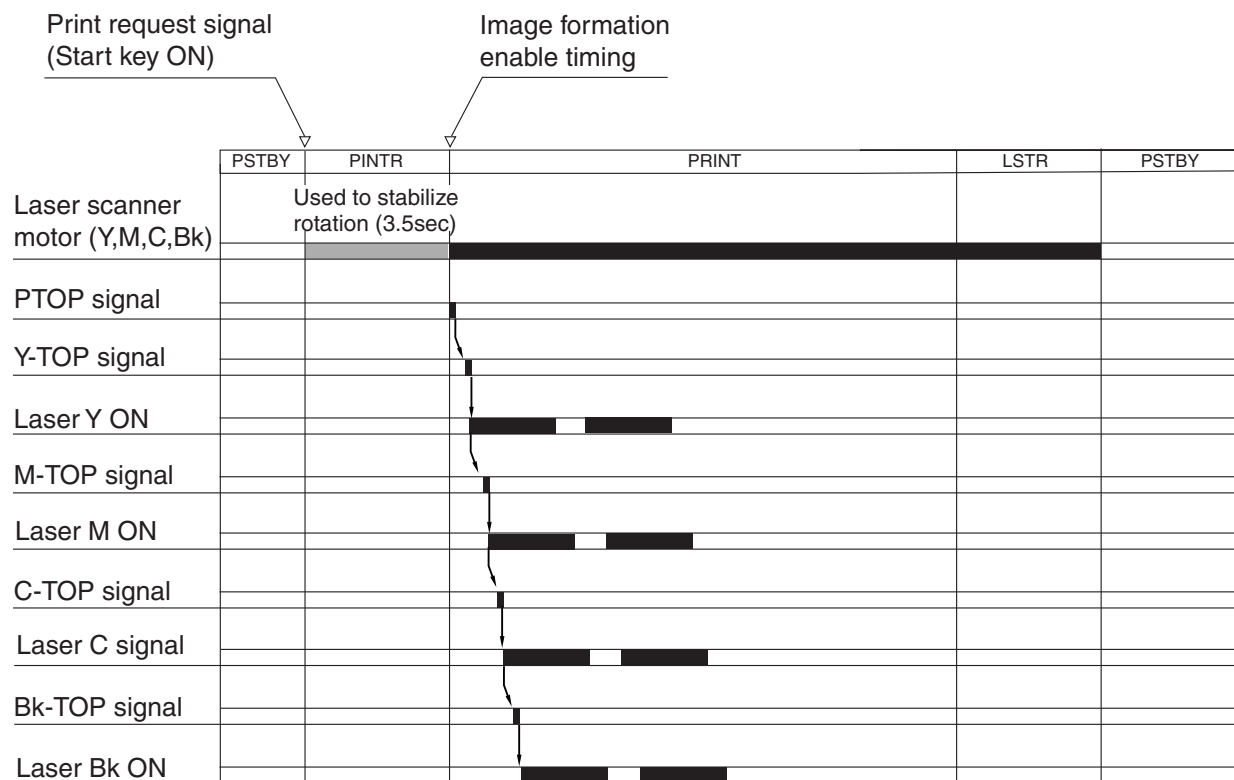

F03-201-05

2.2 Controlling the Intensity of Laser Light

2.2.1 APC Control

The machine uses the photodiode mounted on the laser driver PCB to monitor the intensity of laser light so as to ensure that it remains at a specific level.

2.2.2 PWM Control

- A single pixel is divided into 32, and a 16-level activation pattern is selected to suit the image data in question.

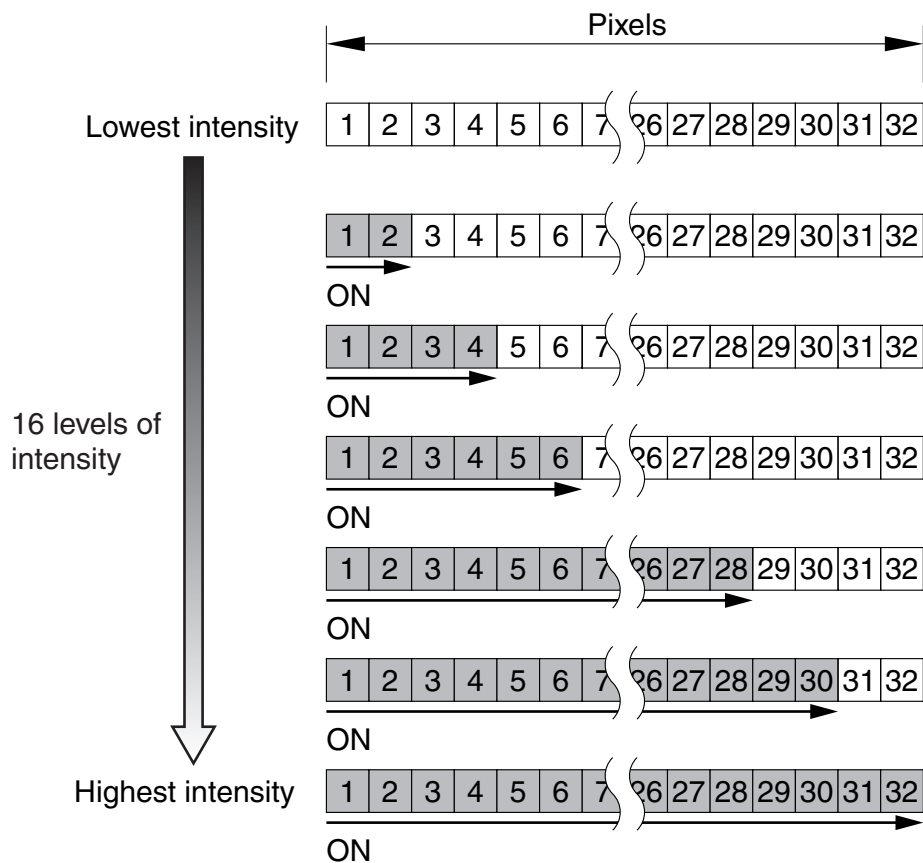

F03-202-01

2.3 Controlling the Laser Scanner Motor

The machine uses the acceleration/deceleration signal to control the speed of rotation of the laser scanner motor so that the BD signal from individual laser units will be of the same phase as the reference signal (if the BD signal is behind the reference signal, accelerate; if ahead, decelerates).

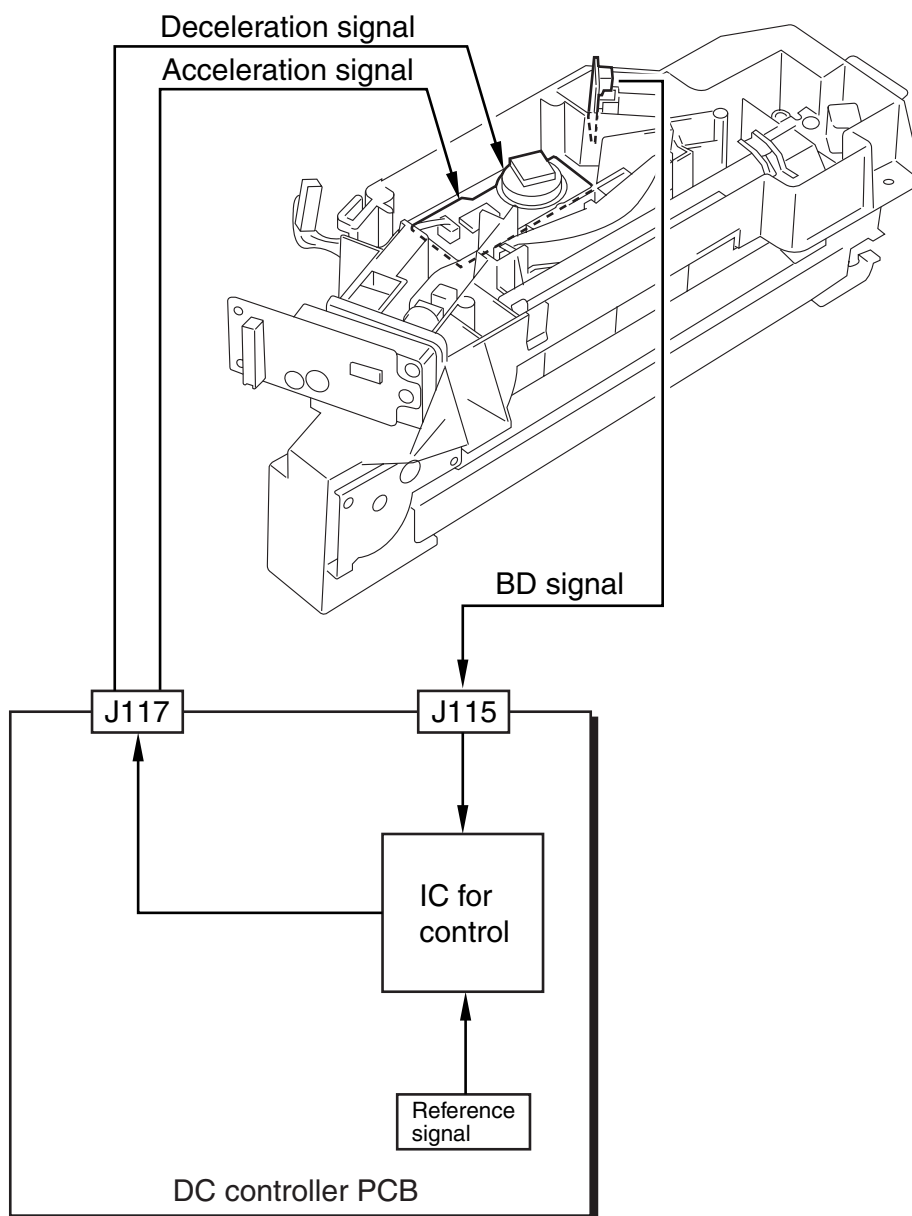

F03-203-01

2.4 Controlling the Laser Shutter

The laser light is turned off whenever a cover (indicated) that can let laser light to escape is opened:

- front cover
- manual feed unit
- fixing feeder unit

If any of the covers (units) is opened, the operation voltage applied to the latest driver is turned off and, in addition, the laser control signal/image signal is also turned off.

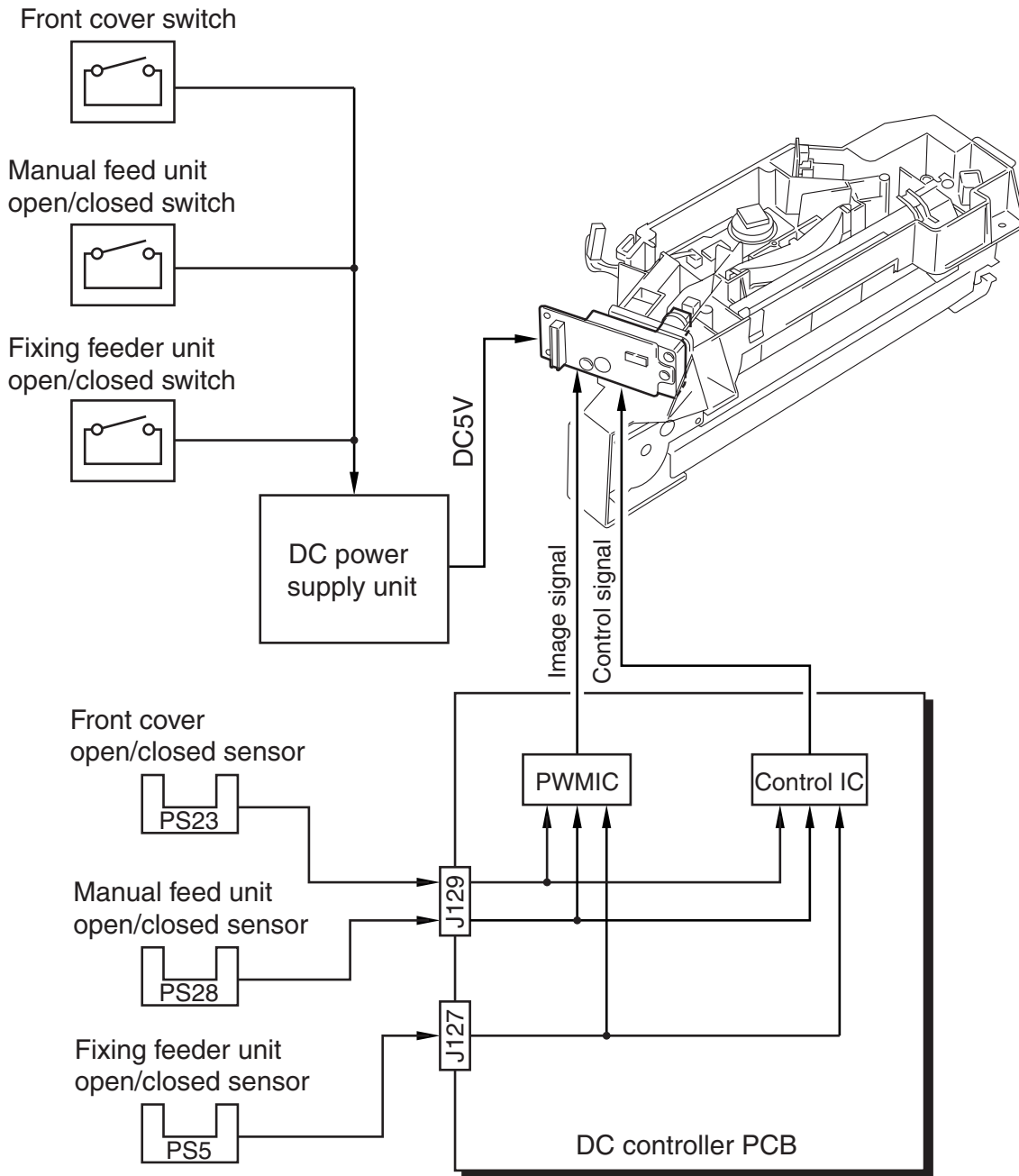

F03-204-01

2.5 Correcting Image Displacement

2.5.1 Outline

The following factors can displace images of individual colors:

- displacement of the photosensitive drum caused by replacement of the drum unit/toner container
→ displacement in sub scanning direction
- displacement of laser path caused by replacement of laser unit
→ displacement/angle in main scanning direction
- displacement in laser path length caused by changes in temperature inside machine
→ variation in magnification

To correct the discrepancies in images, the machine executes corrective control for image position; it detects displacement in color by forming a pattern of a specific color on the transfer belt and reading it against the correct position.

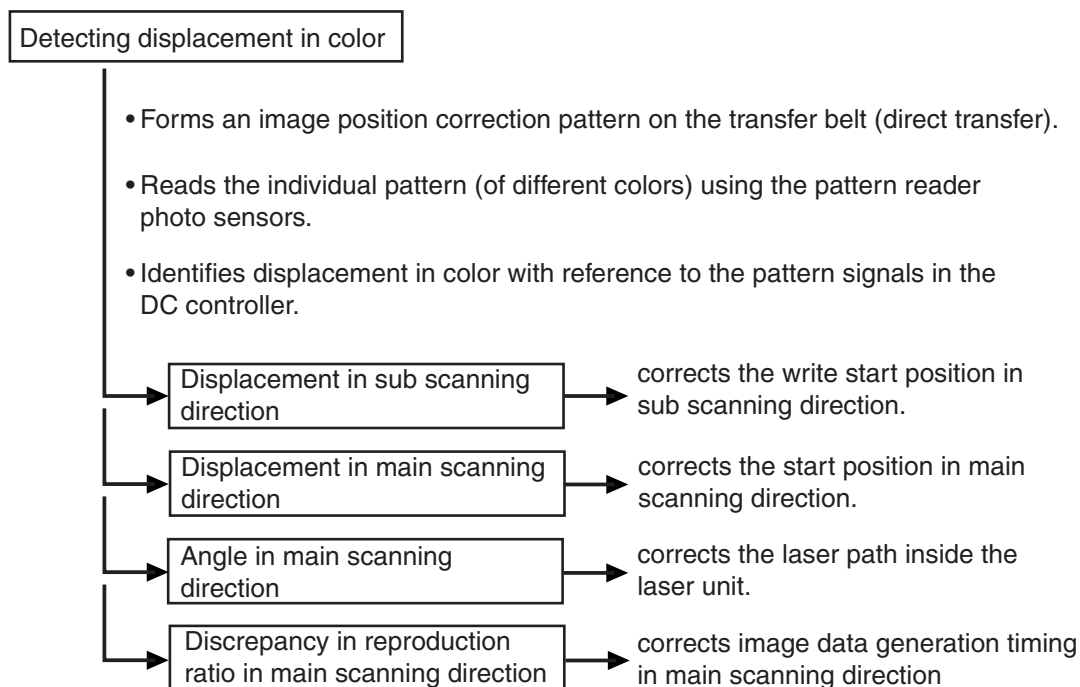

F03-205-01

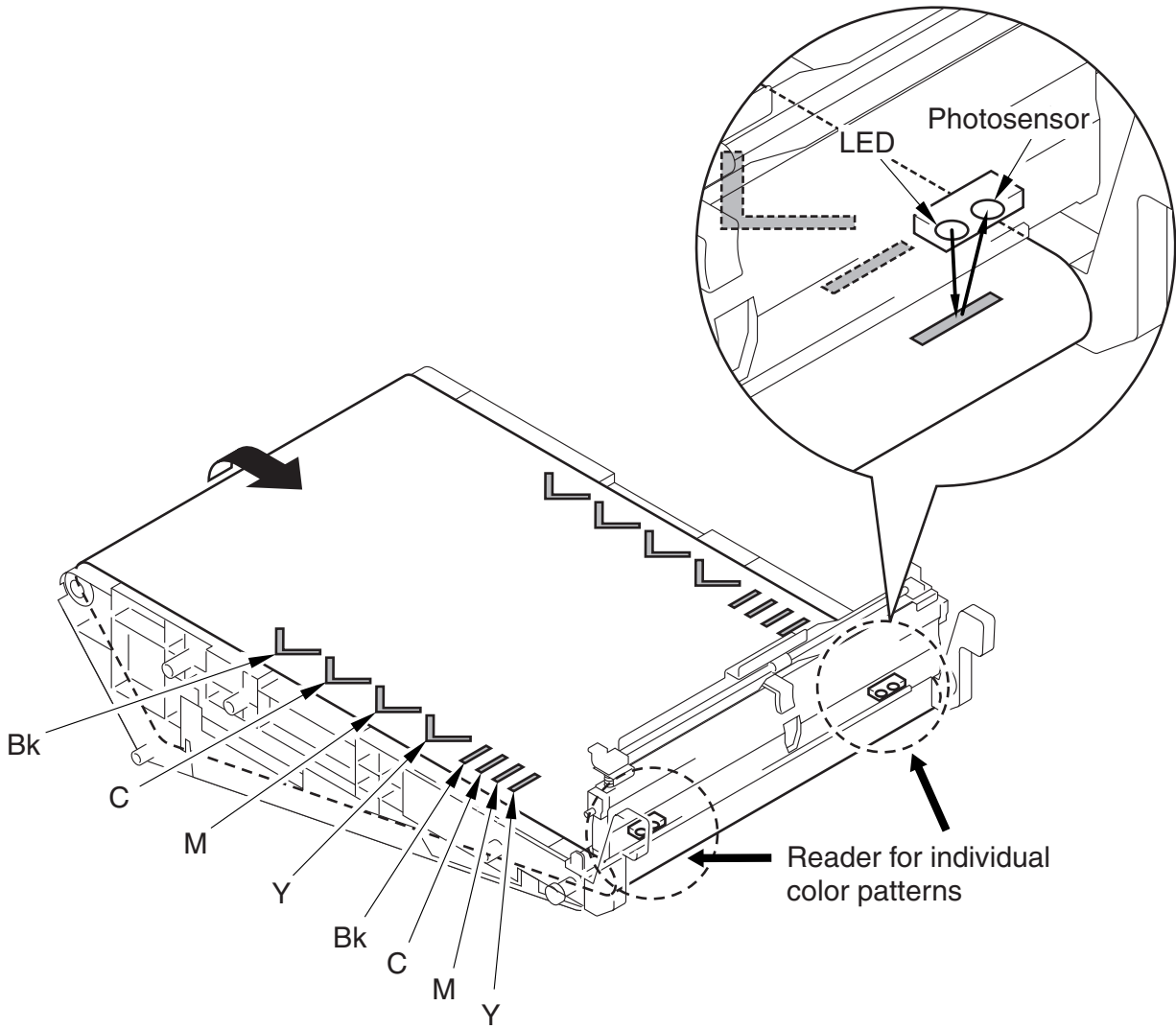

F03-205-02

2.5.2 Timing of Color Displacement Detection/Correction

The machine detects/corrects color displacement at the following timing:

- during warm-up after the main power switch is turned on
- during warm-up after return from sleep
- during warm-up after replacement of the drum unit (not when the toner container is replaced)
- during warm-up when low-power mode is turned on after opening/closing of the cover while the machine is in low-power mode
- 2 hr after the machine has been left alone in standby state
- during quick correction (auto gradation correction)
- after sheet-to-sheet auto correction when 300 sheets (small-size, equivalent in single-sided) have been fed continuously
- during last rotation auto correction at time of counter increments occurring after intermittent jobs of 300 pages (small-size, equivalent of single-sided)

2.5.3 Detecting/Correcting Color Displacement in Sub Scanning Direction

The Y pattern is used as the reference. The machine identifies the degree of color displacement in sub scanning direction with reference to the timing at which other color patterns are checked after a check on the Y pattern.

If the timing is not correct, the machine corrects the laser write start timing in sub scanning direction.

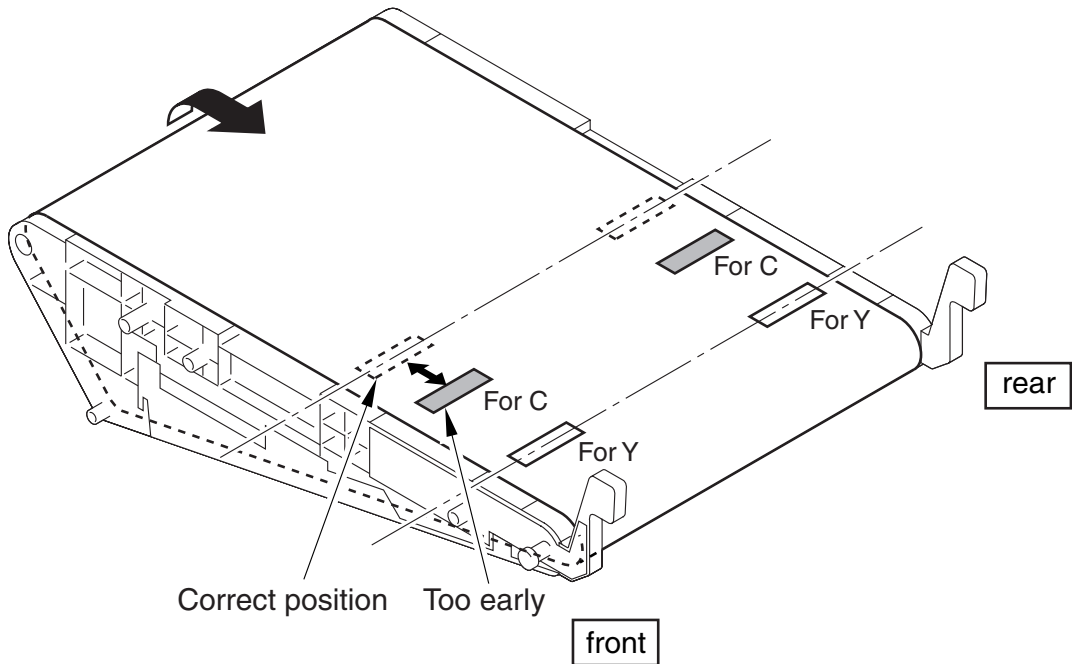

F03-205-03

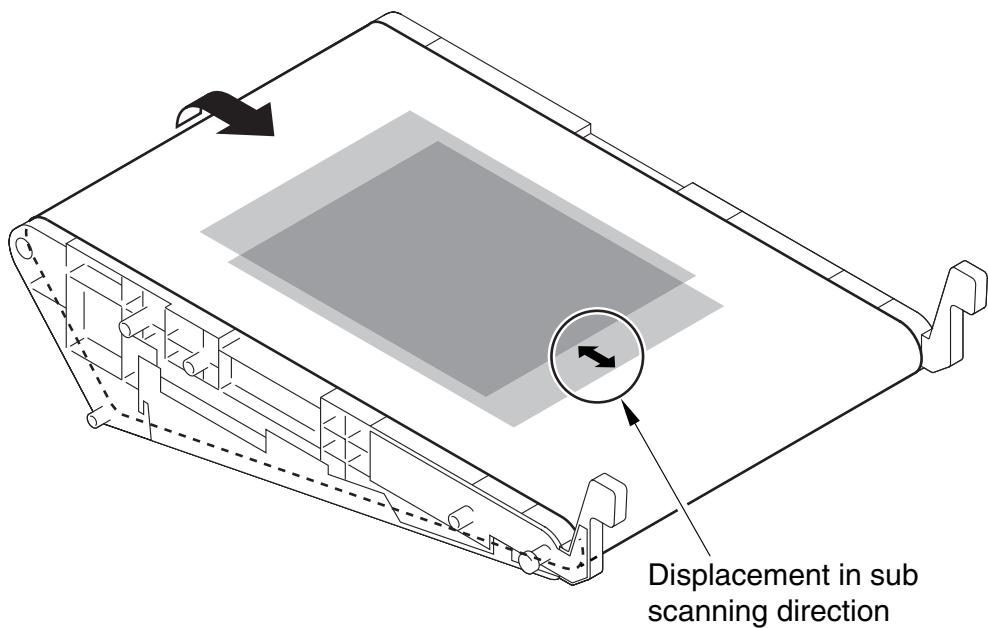

F03-205-04

2.5.4 Detecting/Correcting the Angel in Main Scanning Direction

The Bk pattern is used as the reference. The machine identifies the angle in main scanning direction with reference to front/rear discrepancies of individual colors.

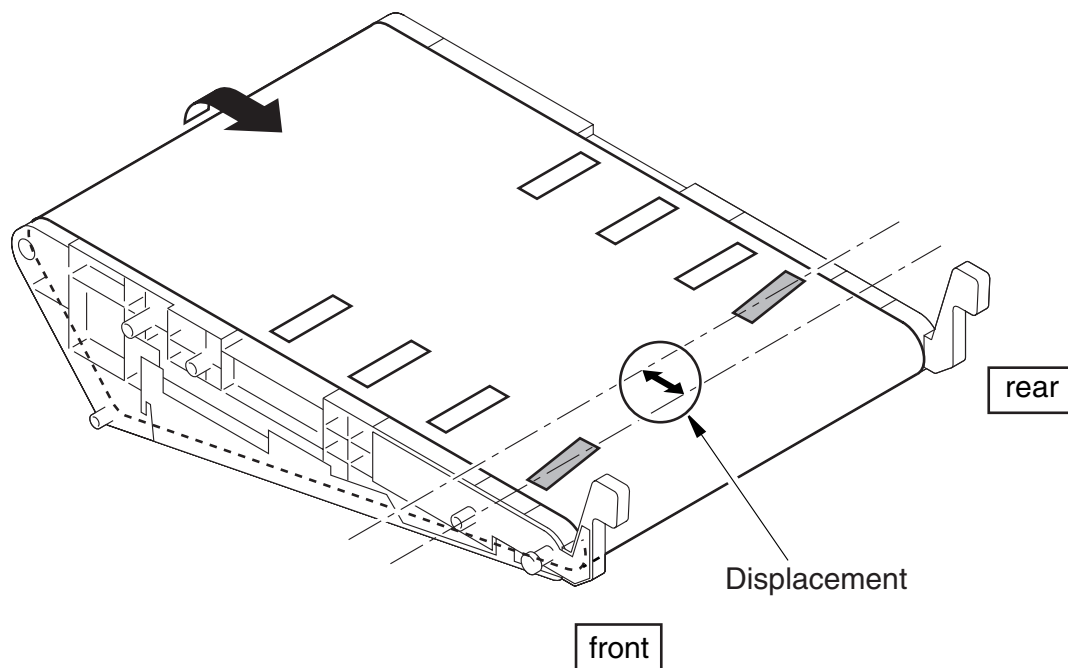

F03-205-05

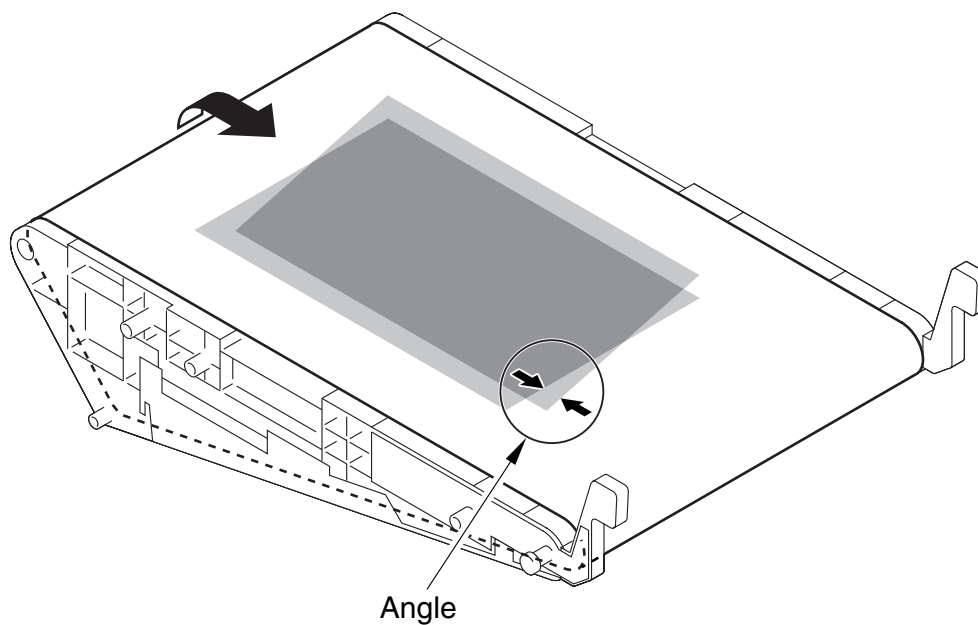

F03-205-06

If the machine detects any angle, it turns on the main scanning direction angle correction motor located inside the laser unit.

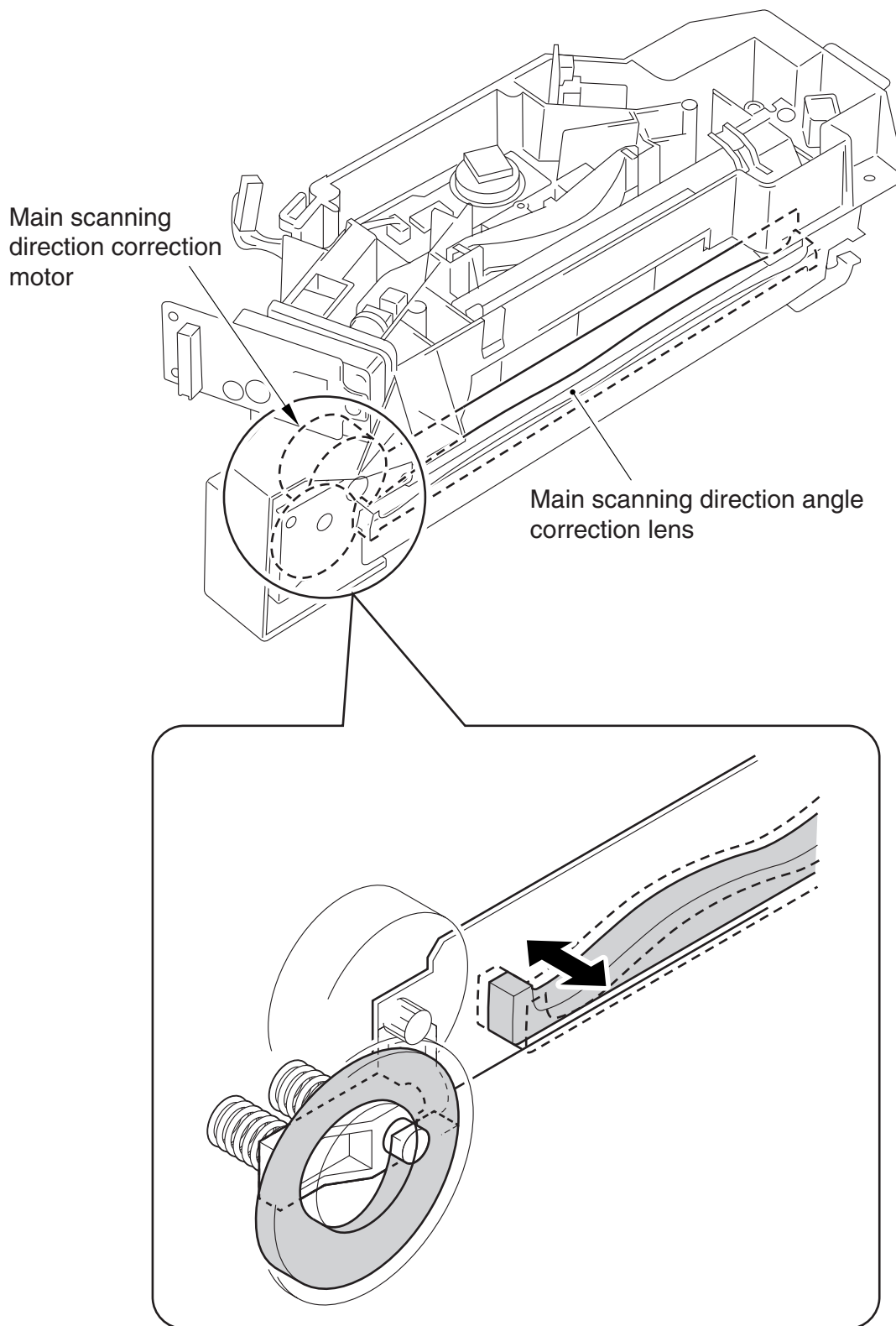

F03-205-07

2.5.5 Detecting/Correcting Color Displacement in Main Scanning Direction

The Bk pattern is used as the reference. The machine compares the length of the center line of the Bk image position correction pattern (front) and the length of the center line of the image position correction pattern (front) of individual colors, and identifies the difference between the two as the degree of color displacement in main scanning direction.

When the machine detects color displacement, it corrects the timing at which the laser is started in main scanning direction.

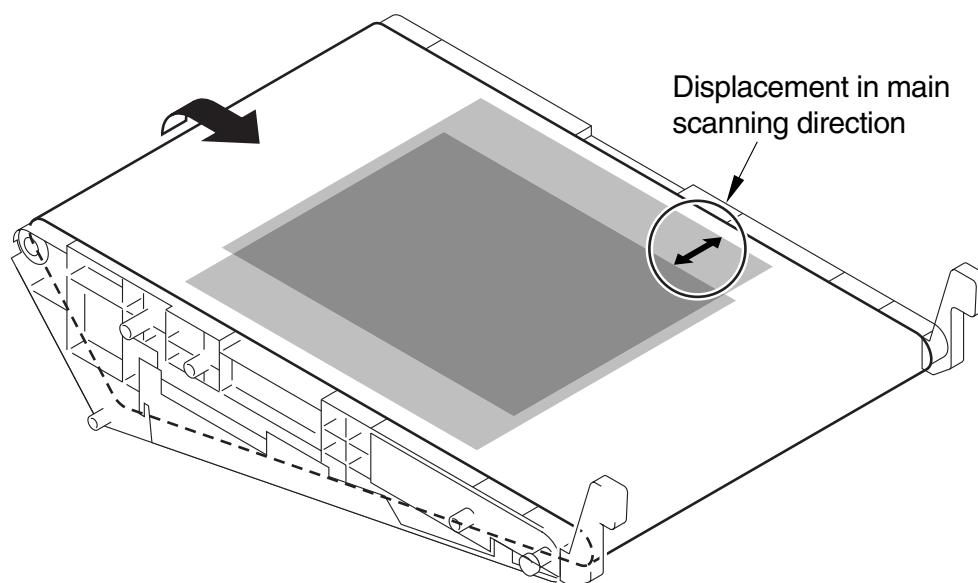

F03-205-08

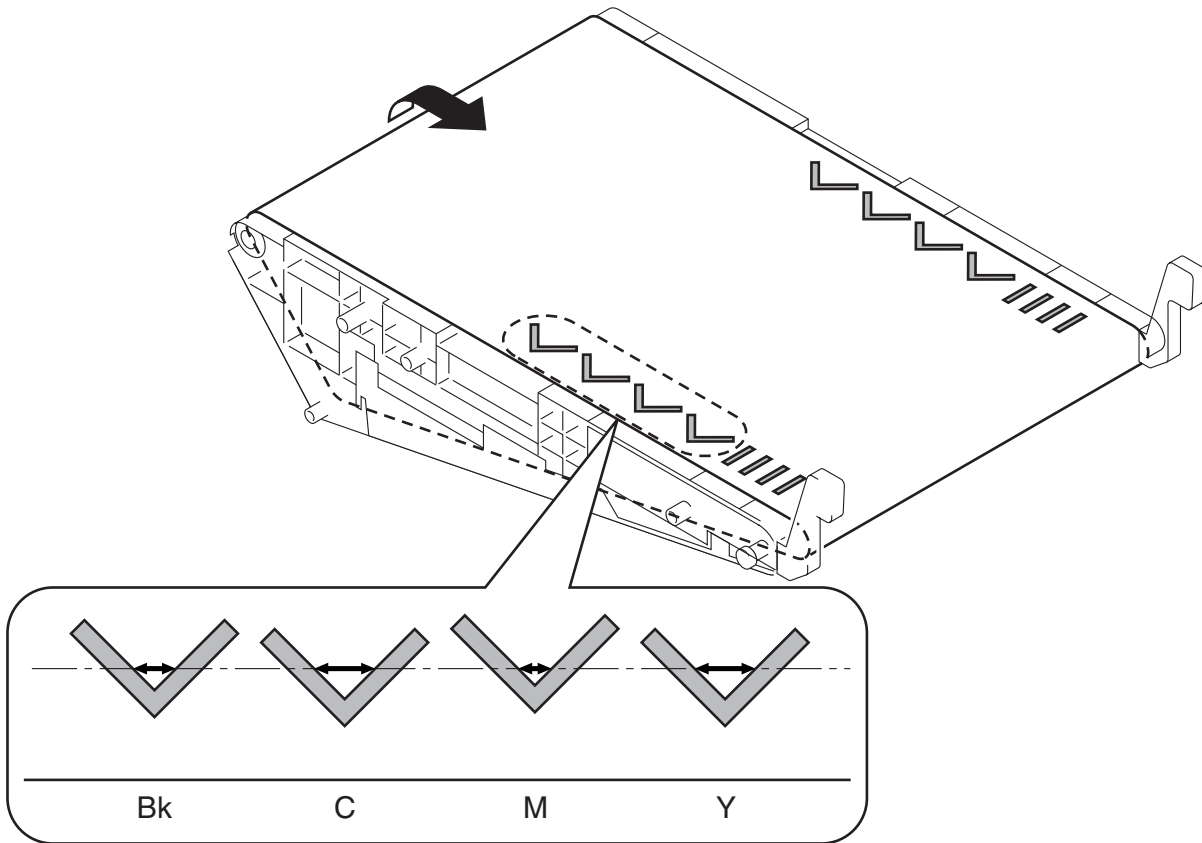

F03-205-09

2.5.6 Detecting/Correcting Changes in the Reproduction Ratio in Main Scanning Direction

The Bk pattern is used as the reference. The machine copies the center line of the Bk image correction pattern (rear/front) and the center line of the individual image position correction patterns (rear/front), and identifies the difference between the two as the change in the reproduction ratio in main scanning direction.

When the machine detects any change, it corrects the timing at which the video signals are transferred to the laser unit.

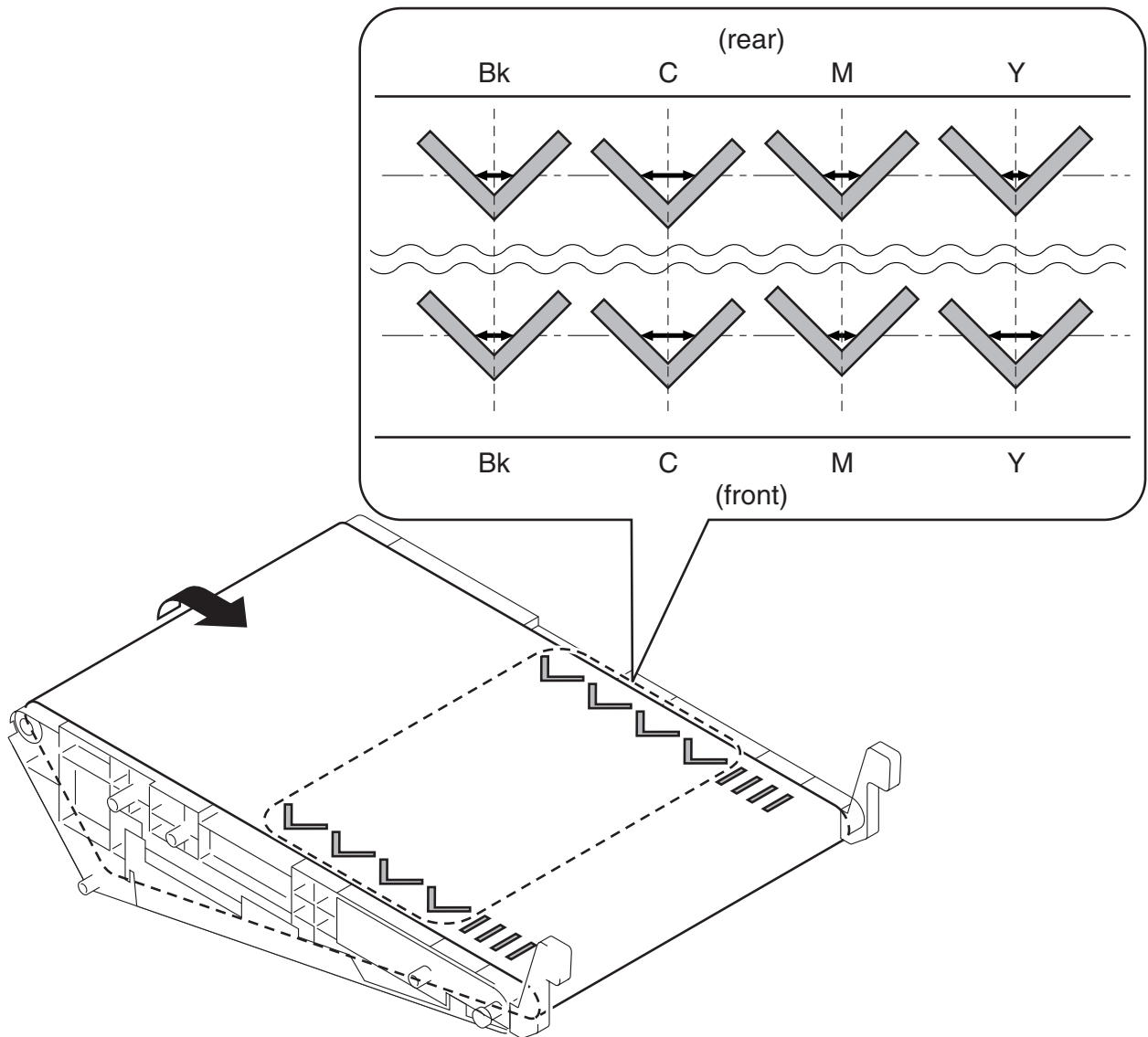

F03-205-10

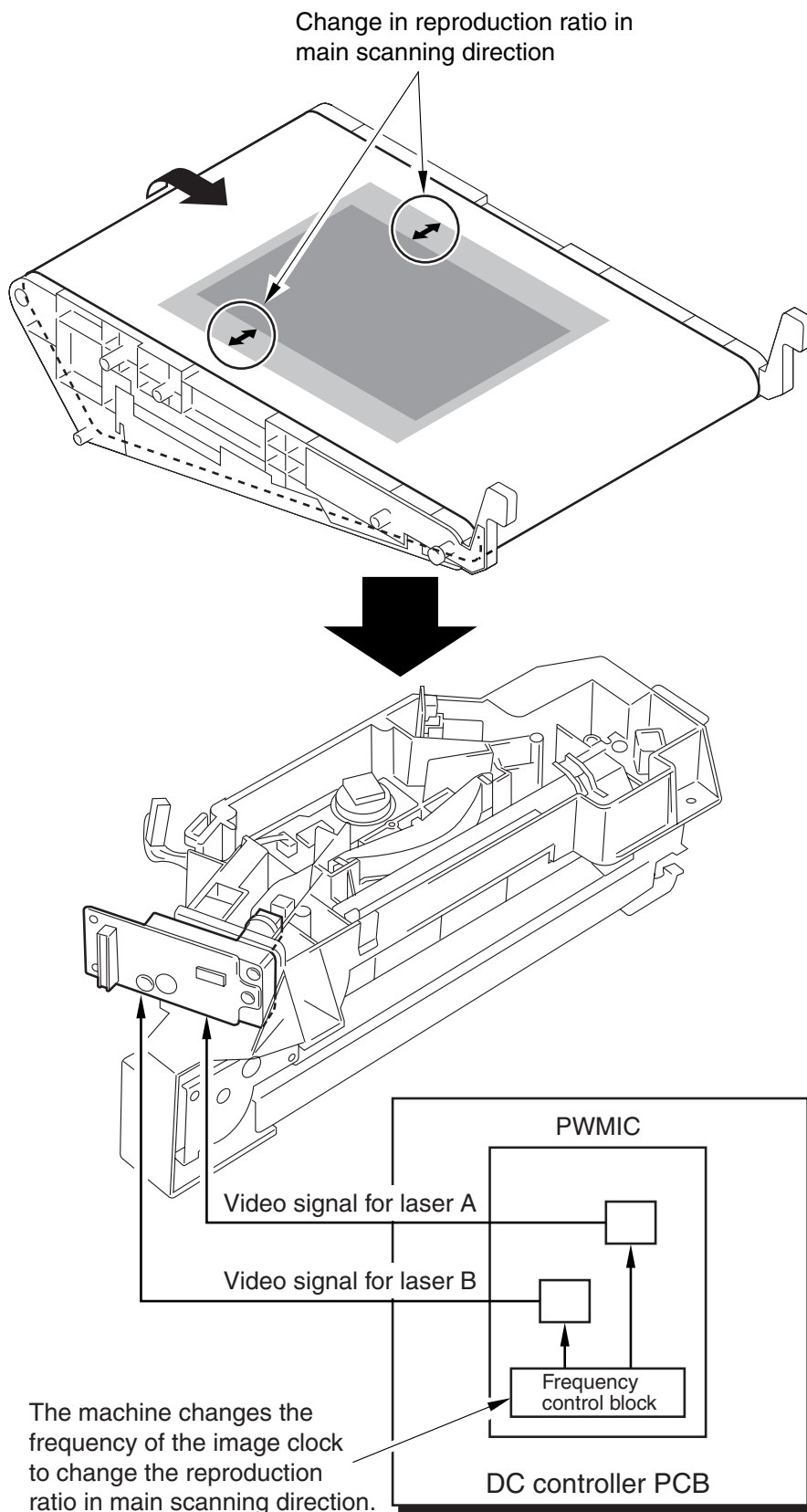

F03-205-11

3 Disassembly and Assembly

3.1 Removing the Laser Unit

- 1) Remove the 2 screws [1], and detach the reader ink unit cover [2].

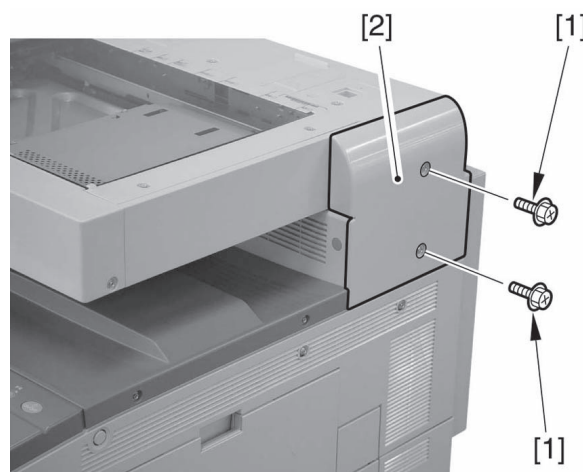

F03-301-01

- 2) Remove the stepped screw [1], and detach the positioning pin [2] from the reader link unit.

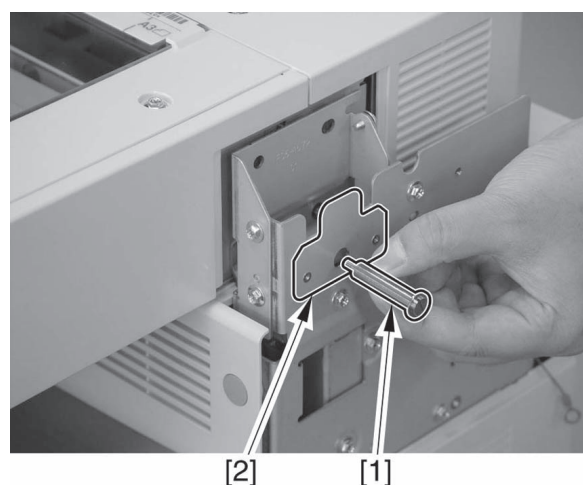

F03-301-02

- 3) Remove the 2 screws [1], and detach the center delivery tray [2].

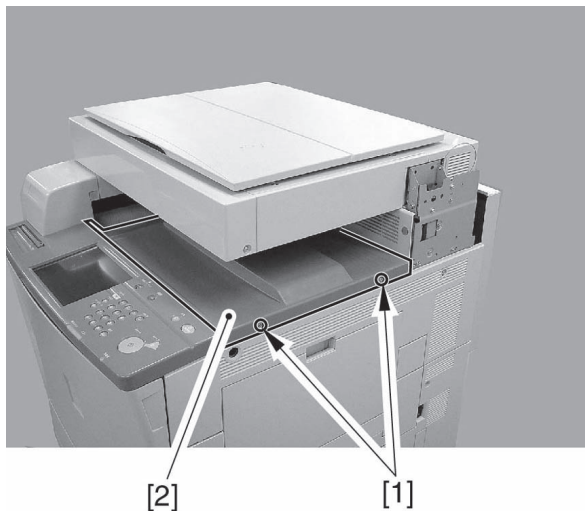

F03-301-03

- 4) Remove the face cap [1] and the screw [2]; then, while lifting the rear reader unit [3] slightly, detach the upper inside cover [4].

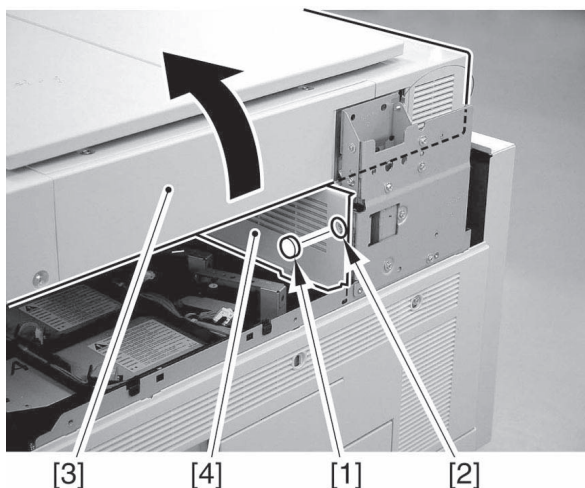

F03-301-04

- 5) Shift the arm [1] of the reader link unit 90° to support the reader unit.

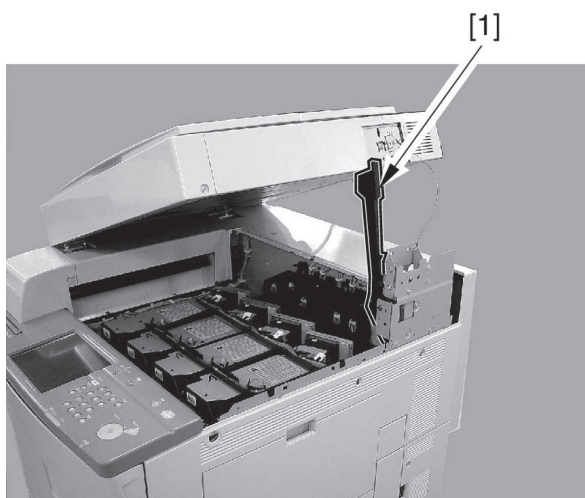

F03-301-05

- 6) Disconnect the 8 connectors [1], and detach the harness guide [2].

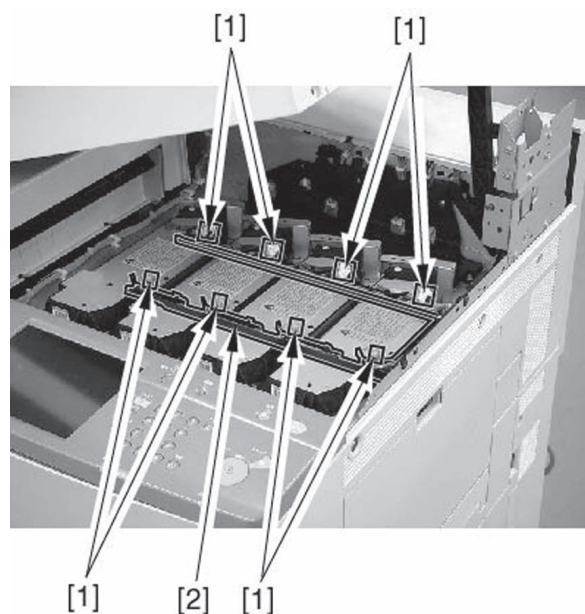

F03-301-06

- 7) Remove the 2 screws [1], and detach the cover [2] of the laser driver PCB.
 (The cover for Y has a different shape, but may be removed in the same way.)

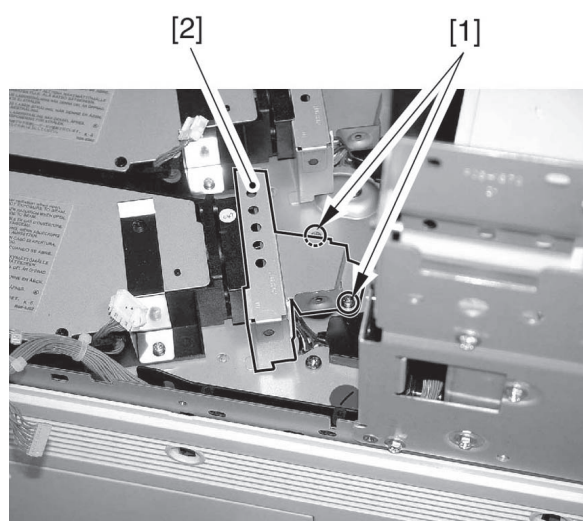

F03-301-07

- 8) Disconnect the connector [1], and remove the 4 screws [2]; then, detach the laser unit [3].

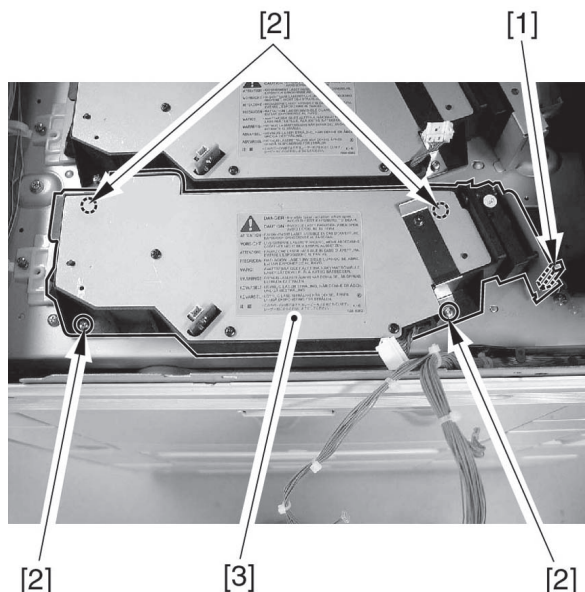

F03-301-08



When mounting the laser unit, tighten the screws in diagonal sequence for proper balance.

3.2 After Removing the Laser Unit

If you have replaced the laser unit, execute the following service mode:
COPIER>FUNCTION>LASER>L-ADJ-0

CHAPTER 4

IMAGE FORMATION

1 Outline of Operation

1.1 Specifications, Control Mechanisms, and Functions

Drum unit (D-UNIT)	Photosensitive drum	
	Type of drum	OPC
	Diameter of drum	30.6 mm
	Cleaning mechanism	Cleaner-less
		The residual toner after transfer is charged for collection by the developing assembly.
	Process speed	130 mm/sec (plain paper) 65 mm/sec (thick paper, special paper, transparency)
	Developing assembly	
	Diameter of developing cylinder	16 mm
	Method of development	dry, 2-component
	Toner	non-magnetic, negative (S toner)
	Detection of toner inside developing assembly	ATR sensor (magnetic sensor)
	Starter	held by drum unit
	Primary charging assembly	
	Method of charging	roller, contact charging
	Diameter of charging roller	14 mm
	Cleaning mechanism	cleaning sheet, in contact (reciprocating movement of 5 mm; cycle of 1.5 sec)
	Auxiliary brush	
	Type of brush	fur brush
	Intrusion of brush	1.3 mm (upstream) 1.3 mm (downstream)
	Others	
	Items of control by internal memory	color of toner inside drum unit cumulative number of prints cumulative number of video counts data on life of drum unit data on toner supply control

T04-101-01

Toner container	Detection of toner level Toner volume	in reference to number of rotations made by toner feedscrew Y : 490 g M : 470 g C : 470 g Bk: 530 g
	Others	
	Items of control by internal memory	color of toner inside toner container data on life of toner container
Inter-mediate transfer unit	Intermediae transfer belt (ITB) Drive for belt Feeding speed Cleaning mechanism	seamless through gears from drum ITB motor 130 mm/sec (plain paper) 65 mm/sec (thick paper, special paper, transparency) cleaning blade
Image stabilization mechanism	Discharge current level control ATVC control ATR control PASCAL control SALT-Dmax control SALT-Dhalf control	to prevent image faults caused by changes in environment to ensure good transfer to correct toner density to correct image gradation characteristics to correct development density (maximum density) characteristics to correct development density (gradation) characteristics

T04-101-02

1.2 Major Components of the Image Formation System

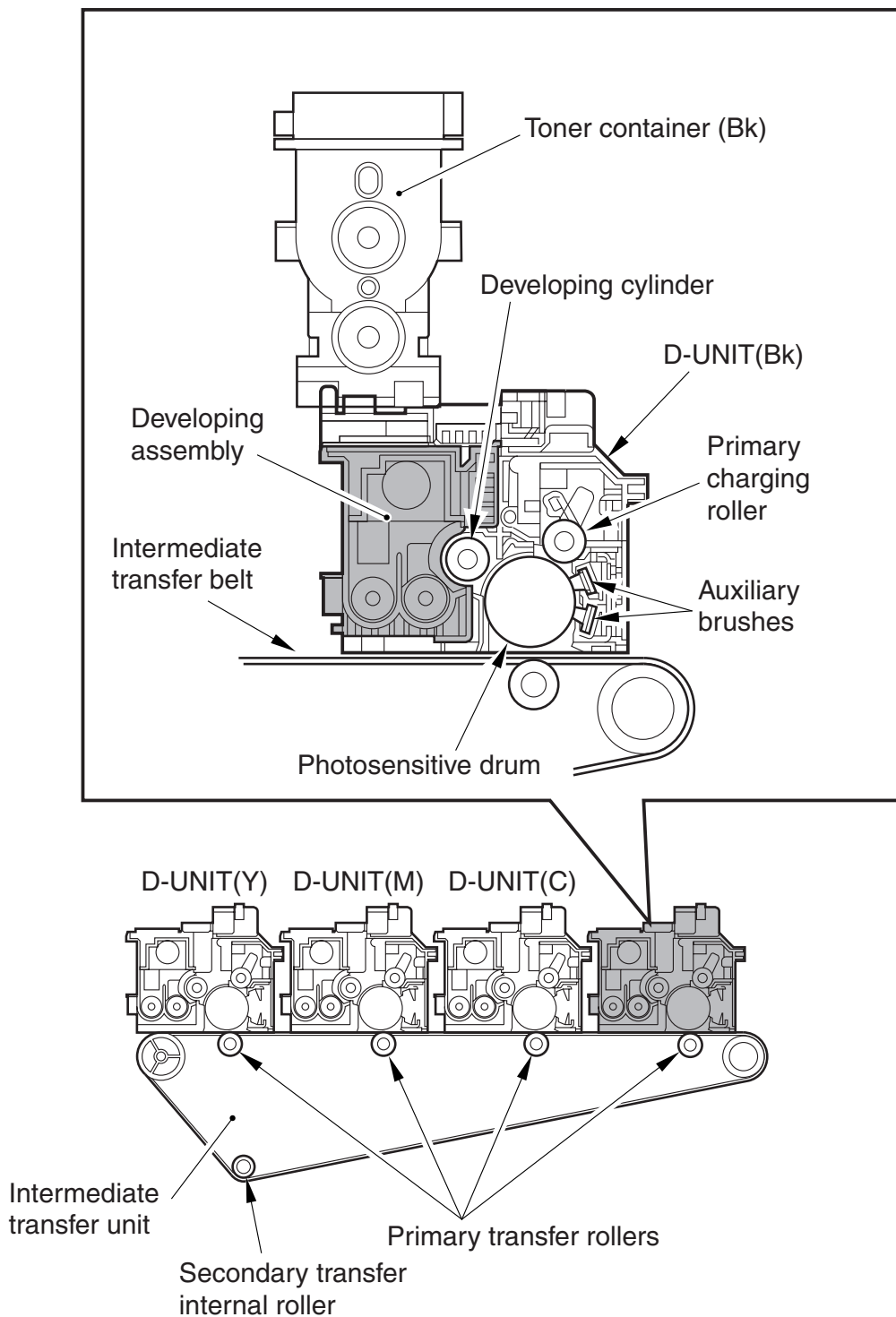

F04-102-01

1.3 Charging Specifications

Drum unit (high voltage)	Photosensitive drum charging	
	Method of primary charging	roller contact
	AC component rating specifications range	1300 to 2000 Vp-p (standard: 1500 Vp-p)
	DC component rating specifications range	-300 to -700 V (standard: -450 V)
	AC component voltage correction factor	environment sensor
	DC component voltage correction factor	environment sensor, SALT sensor
	Auxiliary charging	
	Method of charging	fur brush (upstream, downstream)
	Upstream auxiliary brush AC component rating specifications range	200 Vp-p
	Upstream auxiliary brush DC component rating specifications range	+200 to +300 V (standard: +250 V)
	Downstream brush DC component rating specifications range	-700 to -800 V (standard: -750 V)
	Voltage correction factor	environment sensor
	Developing bias	
	AC component standard value	1800 Vp-p (fixed)
	DC component rating specifications range	-150 to -550 V (standard: -300 V)
	Voltage correction factor	environment sensor, SALT sensor
Transfer unit specifi- cations (high- voltage)	Primary transfer	
	Method of transfer	Roller transfer
	Object of transfer	Transfer belt (ITB)
	DC component rating use range	0 to +1200 V
	Voltage control factor	environment sensor, print mode*
	Secondary transfer	
	Method of transfer	roller
	Object of transfer	paper (transfer media)
	DC component rating use range	-2500 to +7000 V
	Voltage correction factor	paper type, environment sensor reading, print mode*
	*Full color or monochrome mode.	

T04-103-01

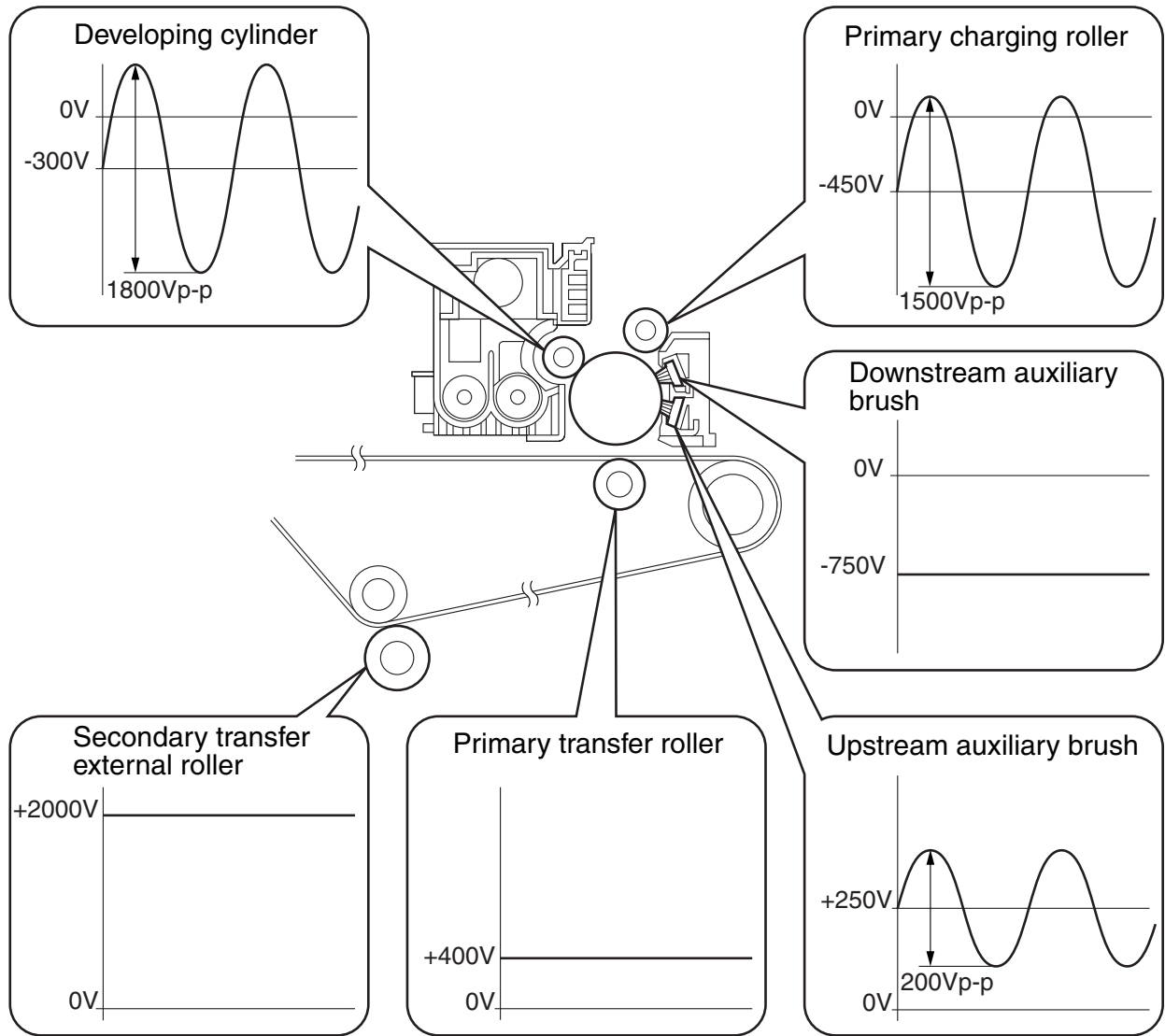

Full color, Plain paper, Normal temperature/humidify

F04-103-01

1.4 Image Formation Process

1.4.1 Image Formation Process (general)

Functional block	STEP	Description
Electrostatic latent image formation block	1, 2	forms an electrostatic latent image on the photosensitive drum.
Development block	3	deposits toner over the electrostatic latent image, thereby turning it into a visible image.
Transfer block	4, 5, 6	moves the toner image to the ITB or paper.
Intermediate transfer belt (ITB) cleaning block	7	collects residual toner from the ITB.
Photosensitive drum cleaning block	8, 9, 10	collects residual toner from the photosensitive drum.

T05-104-01

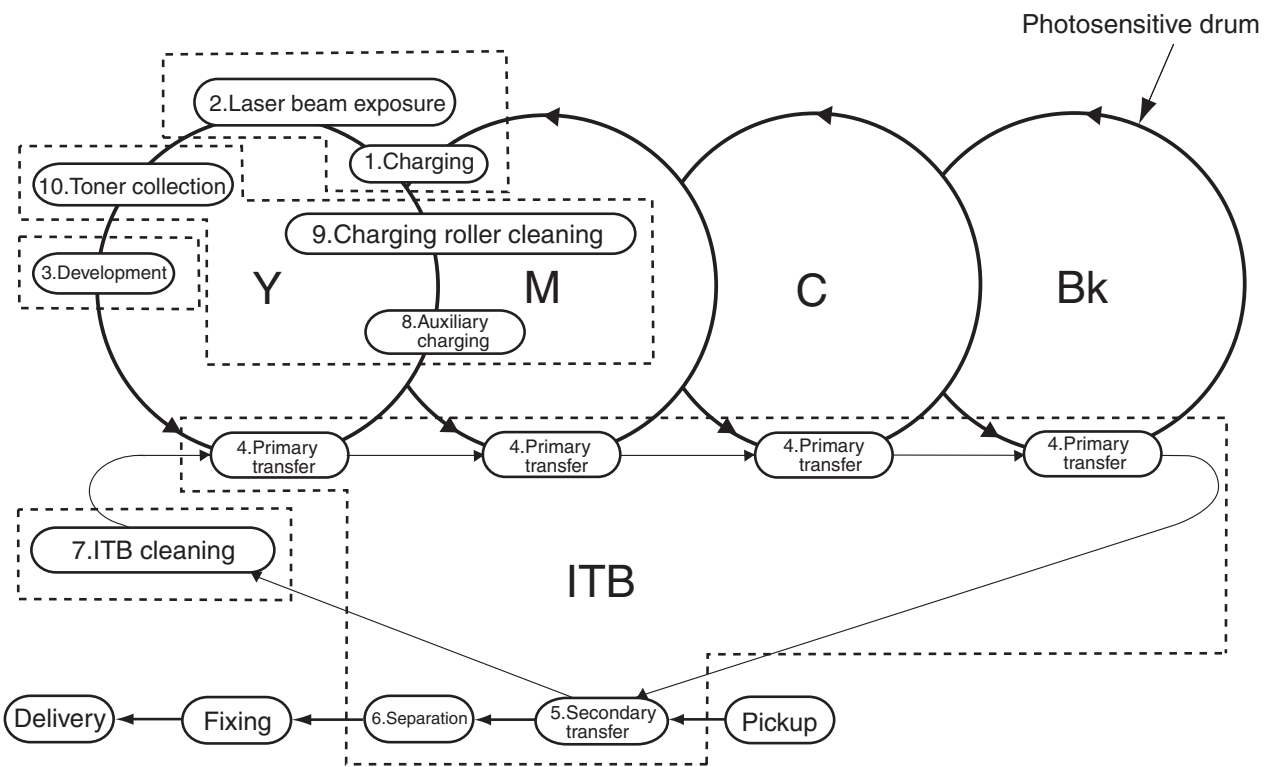

F04-104-01

1.4.2 Image Formation Process (image formation)

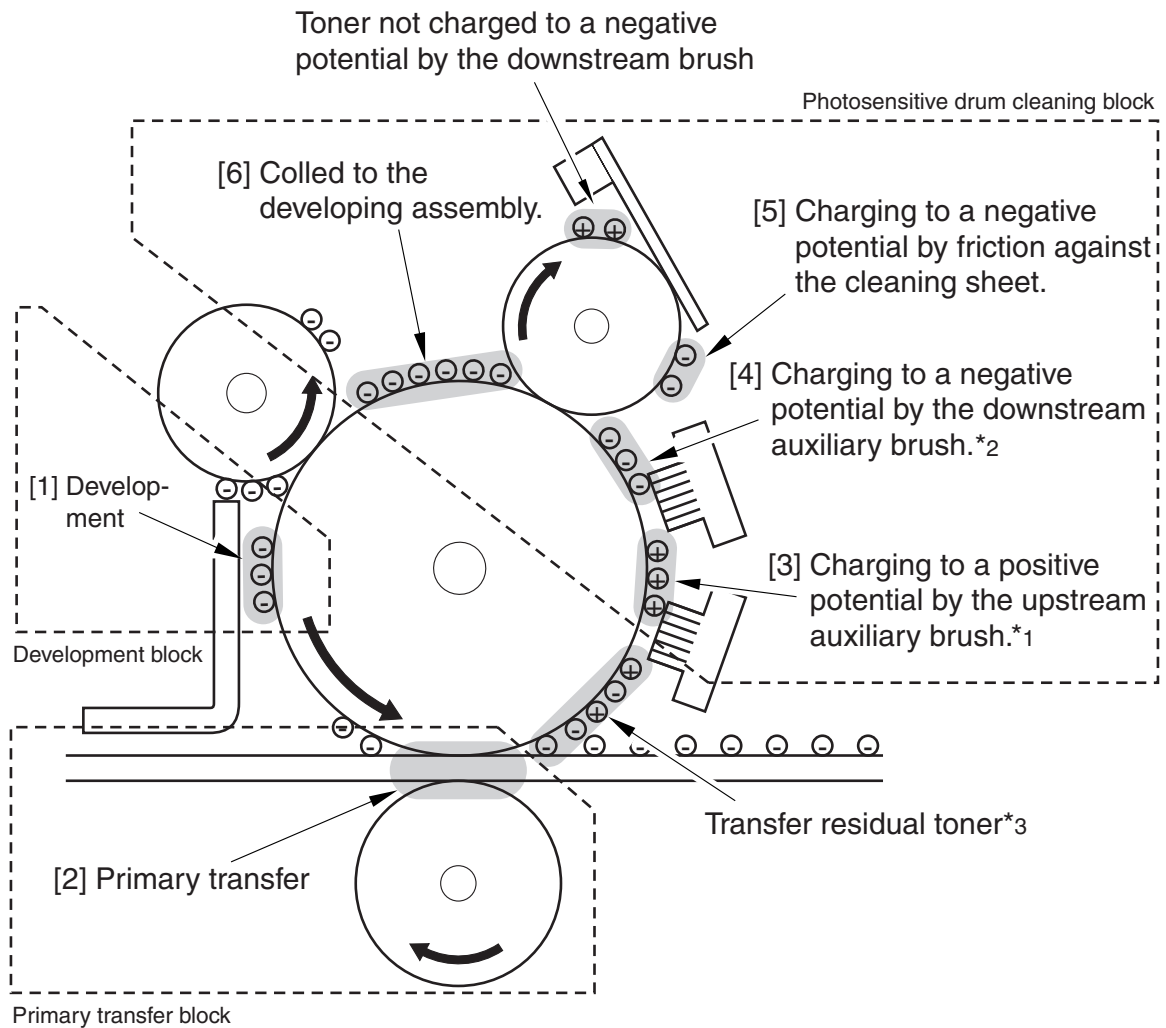

*1: reducing negative charges on toner (removal of charges)

*2: evening out charge to a specific level

*3: toner left behind from secondary transfer
(mix of positive and negative charges)

F04-104-02

1.4.3 Image Formation Process (transfer)

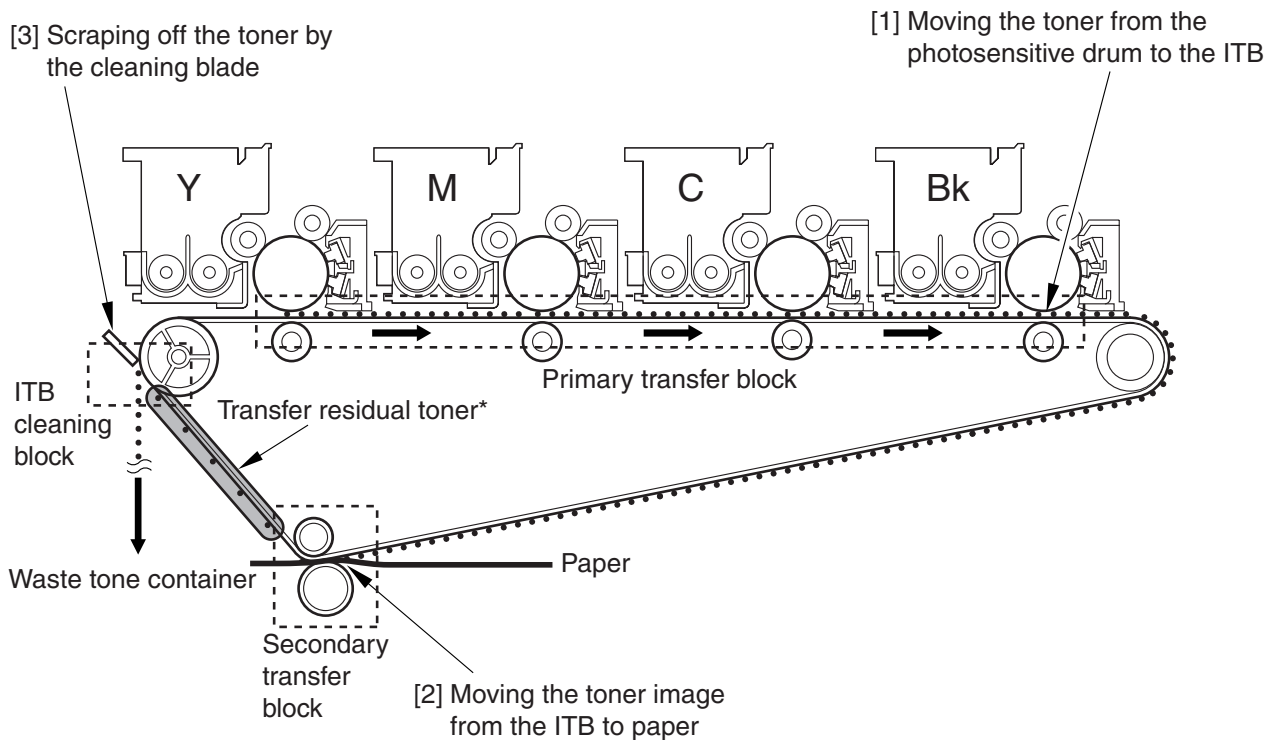

* Toner left behind from secondary transfer.

F04-104-03

1.5 Basic Sequence of Operations

1.5.1 At Power-On (1)

If the main power switch is turned on while the surface temperature of the fixing roller is less than 100°C (e.g., first time in the morning or after a long period of no use),

Characteristics

- the same control timing is used for the Y, M, C, and Bk drum units.
- the machine takes about 300 to 360 sec before it enters PSTBY.
- the machine executes image stabilization control in the following order while it is warming up:
 - discharge current level control
 - ATVC control
 - ATR control
 - SALT-Dmax control
 - image position control
 - SALT-Dhalf control

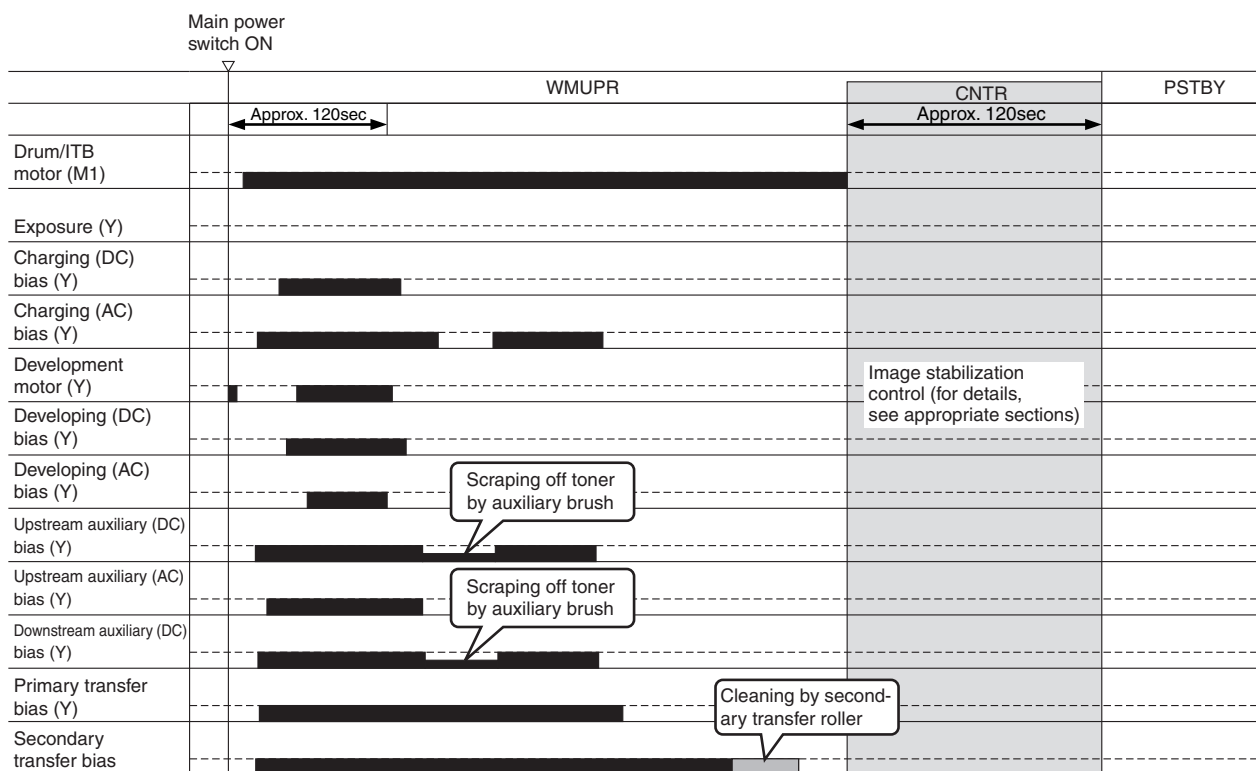

- Start-up sequence of the drum unit (Y; with surface temperature of fixing roller at 100 or more).

F04-105-01

1.5.2 At Power-On (2)

If the main power switch is turned on while the surface temperature of the fixing roller is 100°C or more (i.e., after it returns from jam recovery*, after it has been forced off and then on, or after its front cover has been opened and then closed while an imaged is made).

Characteristics

- the same control timing is used for the Y, M, C, and Bk drum units.
- the machine takes about 80 sec before it enters PSTBY.
- the machine executes image stabilization in the following order while it is warming up:
 discharge current level control
 ATVC control
 image position correction

* If the surface temperature of the fixing roller is less than 100°C after jam recovery, the machine uses the sequence it uses at power-on (1).

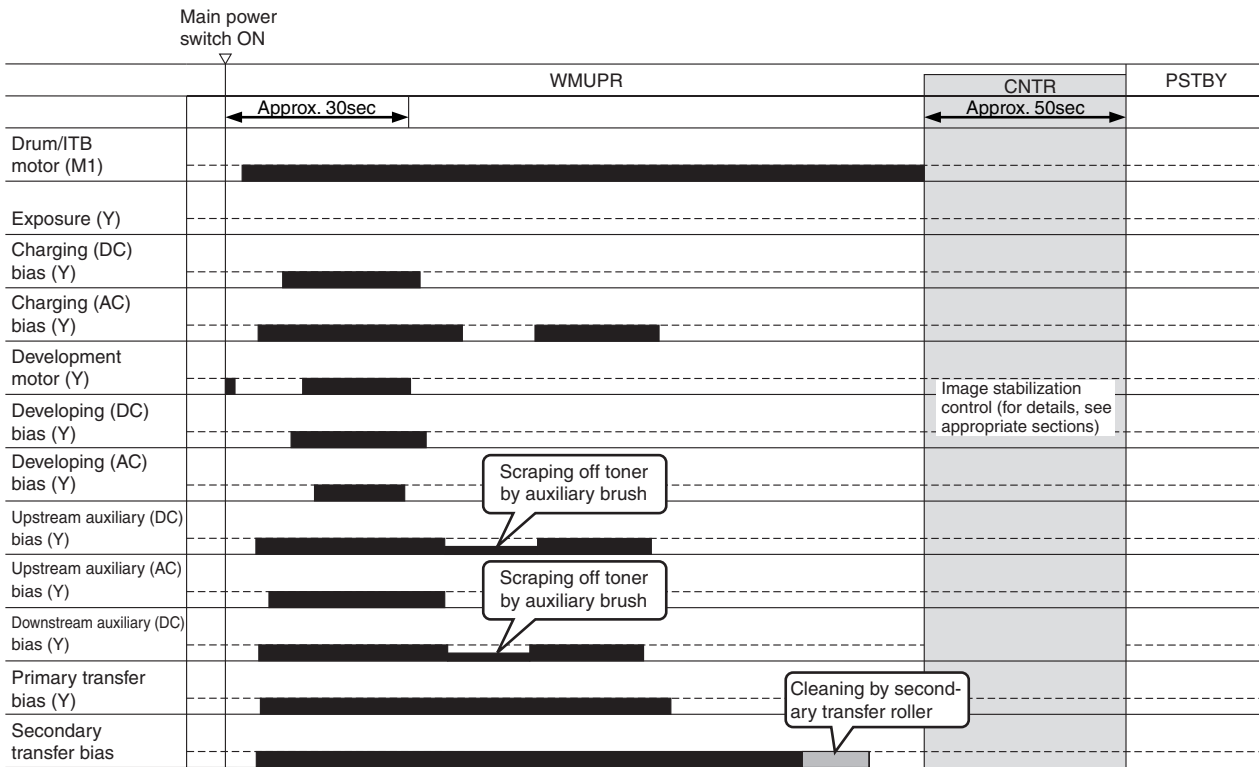

- Start-up sequence of the drum unit (Y; with surface temperature of fixing roller at 100°C or more).

F04-105-02

1.5.3 During Copying/Printing Operations (normal speed)

Full color, Plain paper, A4, 2 copies/prints, Y drum unit

Characteristics

- in response to a press on the Start key, the intermediate transfer belt (ITB) starts to rotate.
- the sequence of operations for drum units after exposure starts with a delay of 0.7 sec each.
- the ITB continues to rotate after delivery of paper from the fixing unit (for post-imaging control).

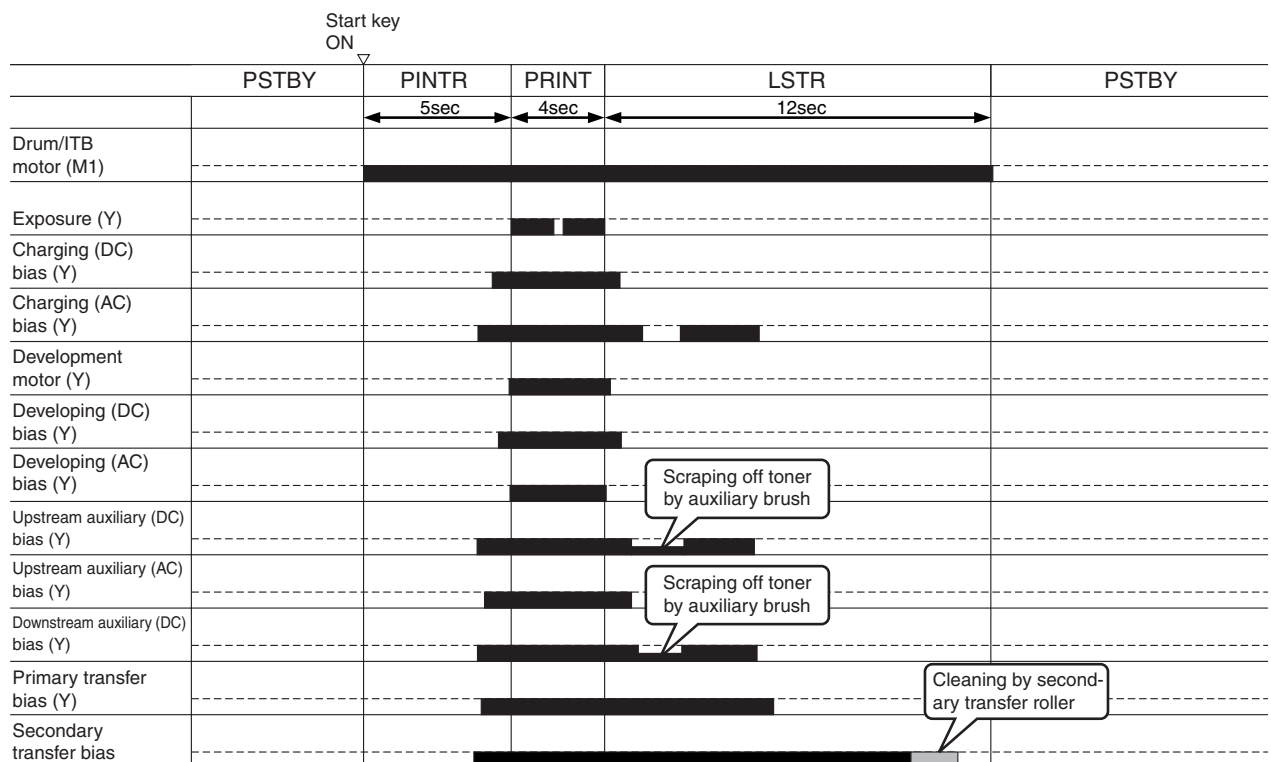

• Y Drum Unit Sequence of Image Formation (plain paper)

F04-105-03

When Making Y/M/C Monochrome Copies/Prints

If not for Bk (i.e., for Y, M, C), a high voltage is applied for the 4 colors as for full-color output when making monochrome copies/prints. (Exposure is not executed for colors other than those in question.)

When Making Bk Monochrome Copies/Prints

When making Bk monochrome copies/prints, no high voltage is applied for Y or M, and C the developing motors for these colors are not driven.

1.5.4 Making Copies/Prints (half speed)

Full color, Thick paper/Special paper/Transparency, A4, 2 copies/prints, Y drum unit

Characteristics

- in response to a press on the Start key, the photosensitive drum and the intermediate transfer belt (ITB) start to rotate
- the sequence of operations of the drum units after exposure starts with a delay of 1.5 sec
- the photosensitive drum and the ITB continue to rotate after paper has been discharged from the fixing unit (for post-imaging control)

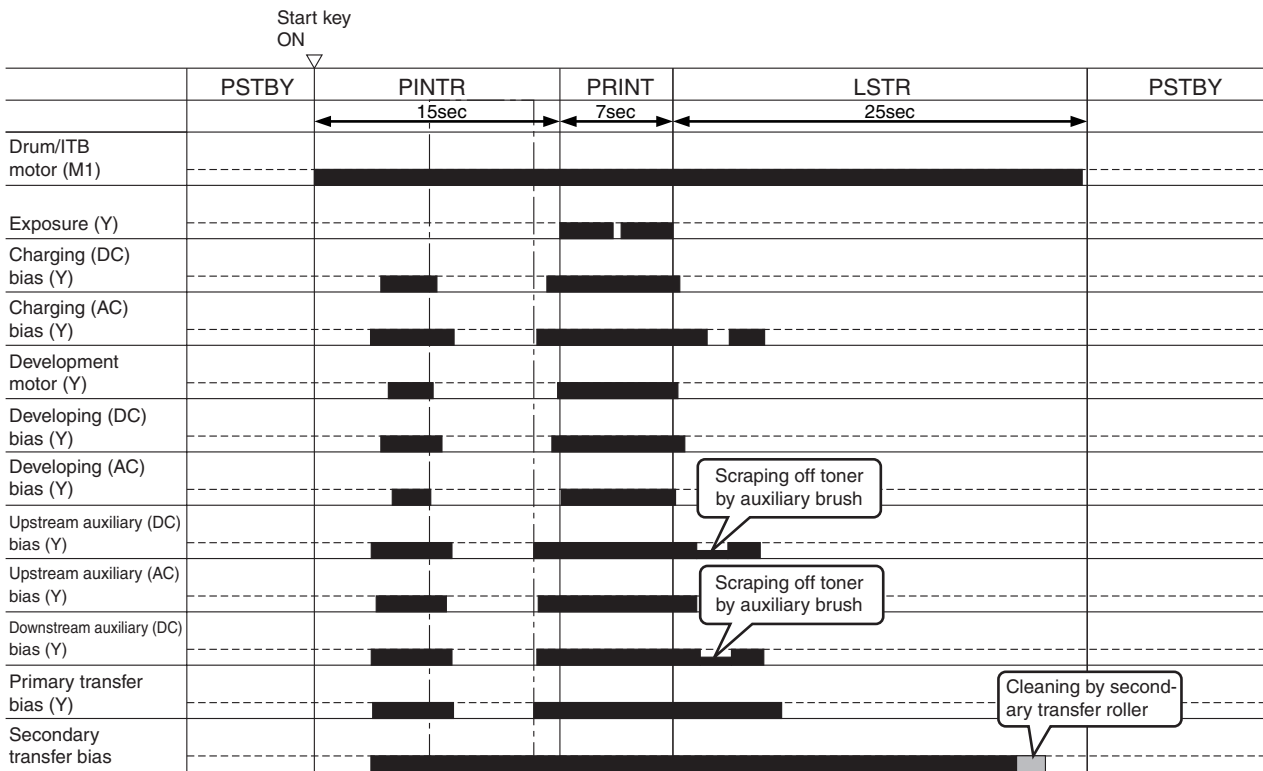

• Y Drum Formation Sequence (thick paper/special paper/transparency)

F04-105-04

1.5.5 After Replacing the Drum Unit (D-UNIT)

When a new drum unit (D-UNIT) has been installed,

Characteristics

- when a drum unit is fitted and the machine's front cover is closed, the developing cylinder starts to rotate.
- so that the developing cylinder may be coated evenly with developer, the cylinder is rotated for 30 sec at the beginning
- if the drum unit is not new, this sequence is not executed; the sequence used at power-on (1) or (2) is executed
- about 150 sec after the drum unit has been fitted, image stabilization control is executed in the following order
 - discharge current level control
 - ATVC control
 - ATR control
 - SALT-Dmax control
 - image position correction
 - SALT-Dhalf control

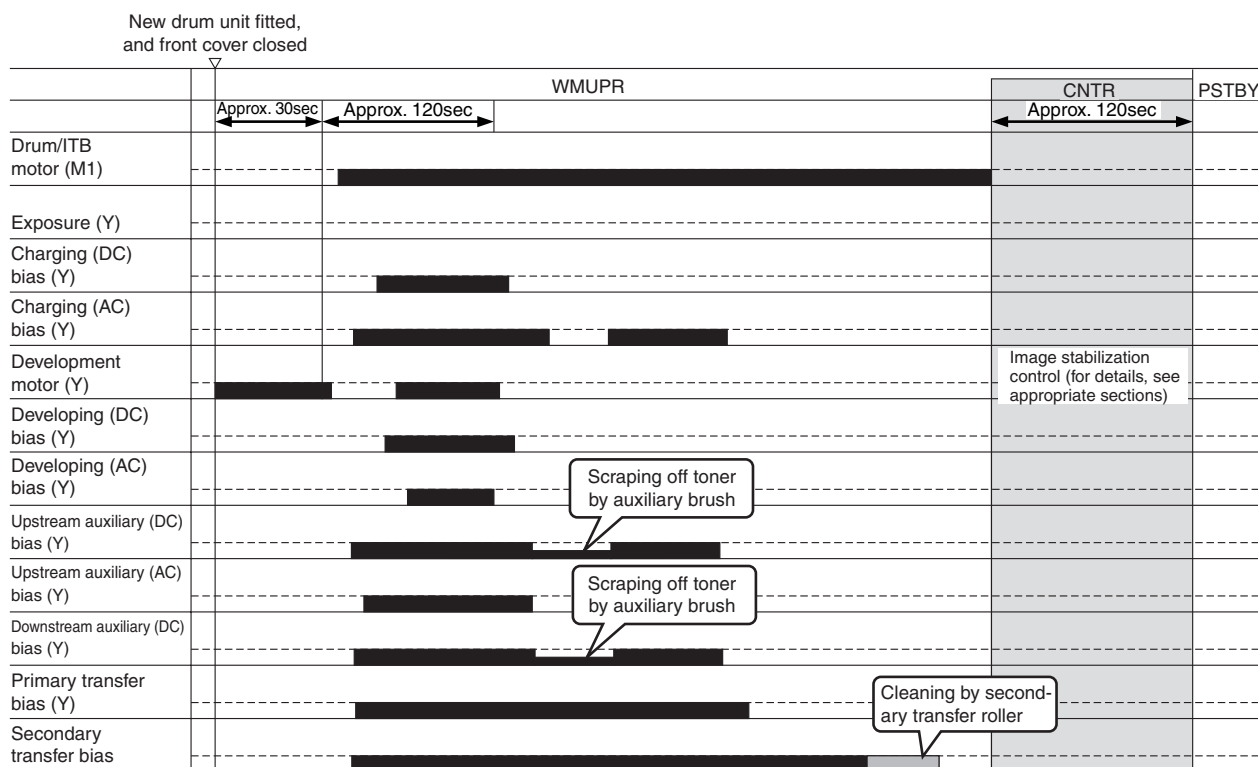

• Y Drum Unit Initialization Sequence

F04-105-05

1.5.6 Printing Originals Containing a Color Page

When making copies/prints of originals containing a color page, the machine uses the following sequence to avoid a drop in productivity:

color original: full-color mode sequence
monochrome original: for 3rd and subsequent copies/prints after color page, full-color mode sequence for 4th and subsequent copies/prints after color page, monochrome sequence



REF.

A switch-over from full-color mode to monochrome mode requires a sequence in which the high voltage of YMC must be lowered. By reducing the use of such a sequence, the machine avoids an appreciable drop in productivity.

1.6 Driving and Controlling the Image Formation System and the High-Voltage System

Drive Control

The image formation system is driven by the toner container motor, developing motor, and drum ITB motor through gears. (For details, see the appropriate sections.)

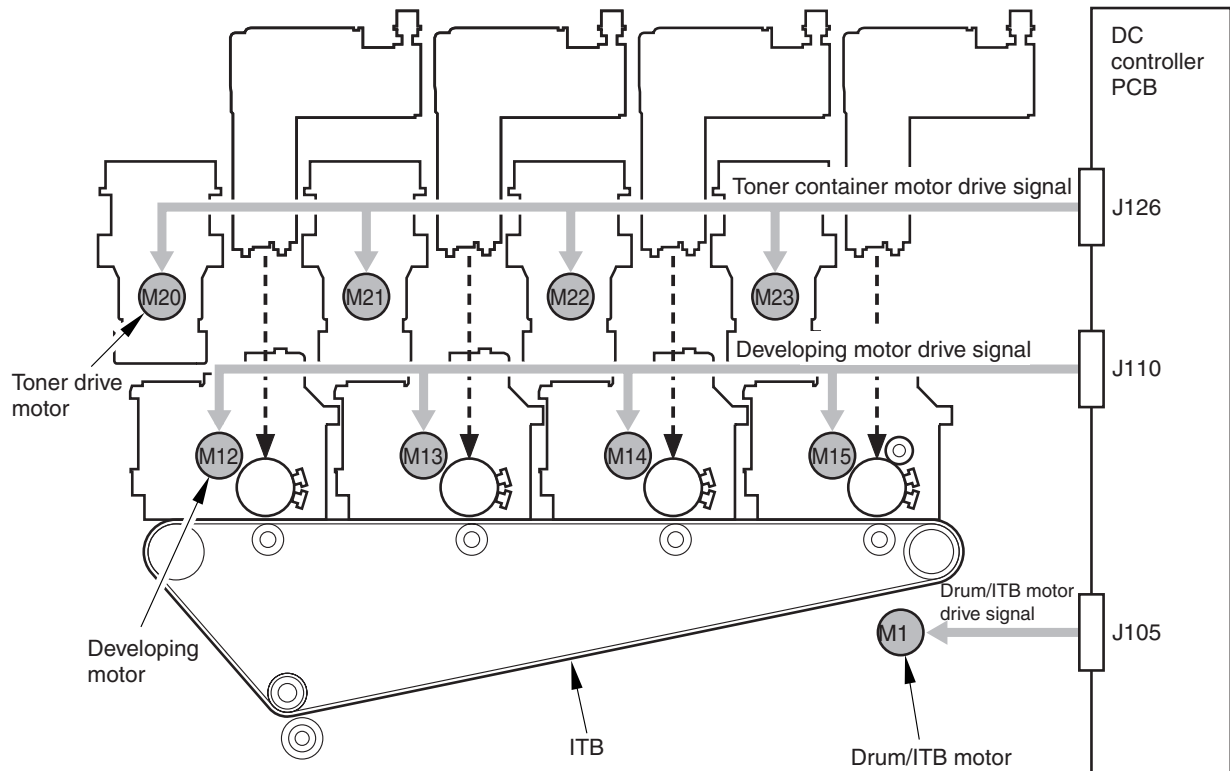

F04-106-01

High-Voltage Control

The high-voltage unit is used to supply high voltage to each of the blocks in the image formation system. (For details, see the appropriate sections.)

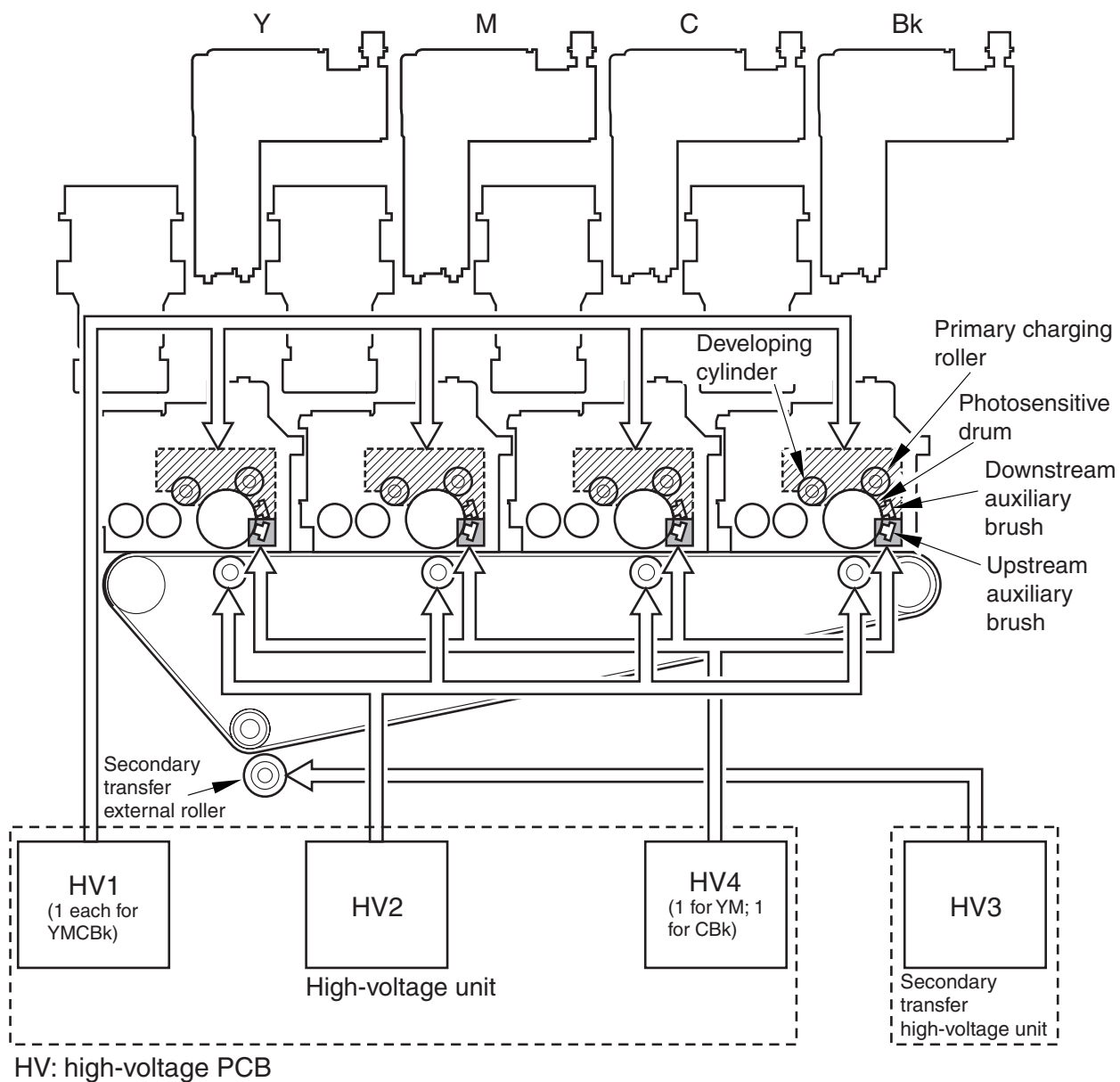

F04-106-02

2 Image Stabilization Control

2.1 Outline of Image Quality Control

Changes in temperature/humidity or passage of time can cause the machine to produce images of varying quality. To ensure that the quality of images remain stable, the levels of voltage outputs and volumes of toner supply are corrected:

So that the machine's image reproduction remains stable, the following control mechanisms are used:

- ATR Control to suit changes in toner density/toner consumption
- Discharge Current Level Control to prevent faulty images in a high humidity environment
(correction of charging AC bias)
- ATVC Control to ensure good transfer
(correction of transfer bias level)
- PASCAL Control/SALT Control to suit changes in image density and gradation
(correction of charging/developing/transfer bias;
correction of image correction table)

2.2 Automatic Image Stabilization Control

Operation	Discharge current level control	ATVC control	ATR control	SALT-Dmax control	Image position correction	SALT-Dhalf control	Estimated duration (sec)
Power-on/ jam recovery	• if fixing roller surface temperature $\geq 100^{\circ}\text{C}$						
	○	○	-	-	○	-	about 80 * ⁶
	• if fixing roller surface temperature $< 100^{\circ}\text{C}$						
	○	○	○	○	○	○	about 240* ⁷
New toner container replacement	• if the number of rotations made by the toner feedscrew has reached the threshold and, in addition, the reading of the ATR sensor is lower than a specific value* ⁸						
	○	○	○	○	○	-	about 190
	• if the number of rotations of the toner feedscrew has reached a specific value (100%)* ⁸						
	-	-	-	-	-	-	about 20
Drum unit replacement	○	○	○	○	○	○	about 280* ⁷
Cover* ¹ opened/closed	• if fixing roller surface temperature $\geq 100^{\circ}\text{C}$ * ²						
	-	-	-	-	-	-	about 20
	• if fixing roller surface temperature $< 100^{\circ}\text{C}$						
	○	○	○	○	○	○	about 240* ⁷
Number of pages* ¹⁰	• cumulative output (number of pages) is 100 or more and less than 200 (LSTR)* ³						
	○	○	○	-	(○: 300 pages* ⁹)	-	about 30 (50)
	• cumulative output (number of pages) is 100 or more and less than 200 (INTR)* ³						
	○	○	-	-	-	-	about 15
	• cumulative output (number of pages) reaching 200 pages or more* ³						
	○	○	○	-	(○: 400 pages* ⁹)	-	about 30 (50)
	• cumulative output (number of pages) reaching 500 pages or more (LSTR)* ³						
	○	○	○	○	(○)	-	about 50 (70)
Left alone in STBY for 2 hr* ³ /Rapid change in environment	○	○	○	○	○	○	about 120
Return from low power mode state	• cover is not opened and closed during low power mode						
	-	-	-	-	-	-	about 30 * ⁴
	• cover is opened and closed during low power mode						
	○	○	-	-	○	-	about 80 * ⁶
Return from sleep state	• STBY + power save mode lasts 1.9 hr or more before starting sleep mode						
	○	○	○	○	○	○	about 240* ⁷
	• STBY + power save mode lasts less than 1.9 hr before starting sleep mode* ⁵						
	○	○	(○)	(○)	○	(○)	about 80* ⁶ (about 240* ⁷)

T04-202-01

- *1 The term “cover” refers to all covers.
- *2 If the cover is opened and then closed again before the machine will be standby state (fixing roller surface temperature $\geq 100^{\circ}\text{C}$), the sequence used for ‘cover opened/closed’ (i.e., fixing roller surface temperature $< 100^{\circ}\text{C}$) is executed.
- *3 See the description or the service mode item in question.
- *4 The duration refers to the period of time for the fixing roller surface temperature to reach a level ready to start a job.
- *5 The condition depends on the fixing roller surface temperature upon return from sleep mode.
- *6 Time that includes about 30 sec of various operations taking place before image stabilization control starts.
- *7 Time that includes about 150 sec of various operations taking place before image stabilization control starts.
- *8 The toner container is identified as having reached the end of its life.
- *9 If the counter reading for image position correction is 300 pages or higher, image position correction is executed together with other image stabilization control mechanisms.
- *10 The counters used in relation to a specific number of pages are of the following 3 types:
 - used to set up discharge current level control, ATVC control, ATR control
 - used to set up discharge current level control, ATVC control, ATR control, SALT-Dmax control
 - used to correct image position

* The control mechanism executed after processing a specific number of pages is executed at the following timing of operation:

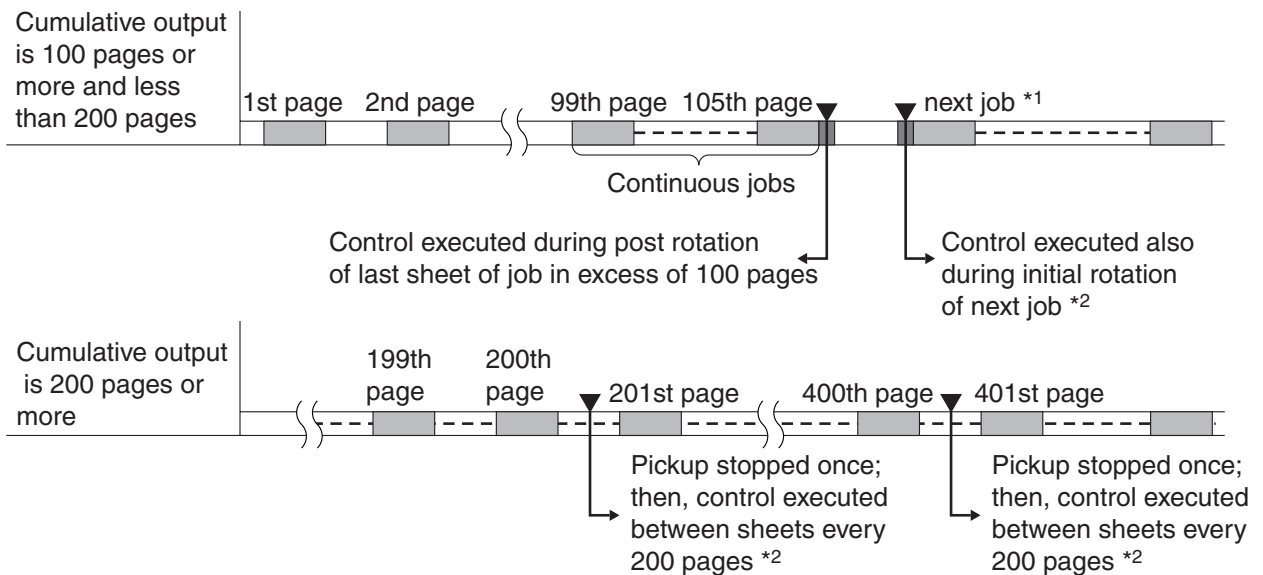

*1 : job next to the one ending in excess of 100 pages.

*2 : counter reading returns to '0' when control is executed.

▼: timing at which control is executed.

F04-202-01



COPIER>OPTION>BODY>INTROT-1

Use it to change the intervals between sessions of execution of image stabilization control (adjustment set-1) for initial/last rotation in terms of the number of pages.

Default (at shipment/upon RAM initialization): 100

COPIER>OPTION>BODY>INTROT-2

Use it to change the intervals between execution sessions of image stabilization control (adjustment set-2) for initial/last rotation in terms of the number of pages.

Default (at shipment/upon RAM initialization): 500

COPIER>OPTION>BODY>PPR-1

Use it to change the intervals of execution sessions (adjustment set-1) for image stabilization control between sheets in terms of the number of pages.

Default (at shipment/upon RAM initialization): 200

COPIER>OPTION>BODY>INTROT-T

Use it to change the intervals of execution sessions for image stabilization control for standby.

Default (at shipment/upon RAM initialization): 2

COPIER>OPTION>BODY>ADJ-LVL

Use it to change the execution mode settings for image stabilization control for a specific number of pages.

Default (at shipment/upon RAM initialization): 0

2.3 ATR Control

The machine executes ATR control to maintain a specific image density, which otherwise would change as more and more toner is used. The machine measures the concentration of toner and adjusts its supply.

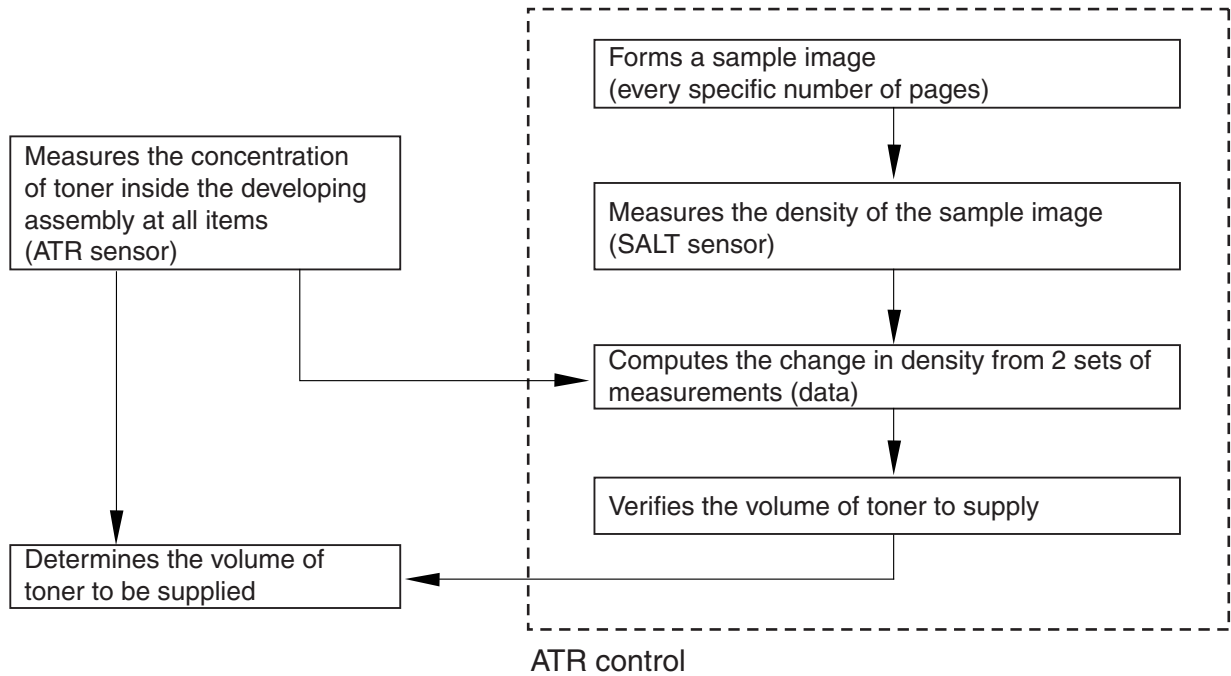

F04-203-01

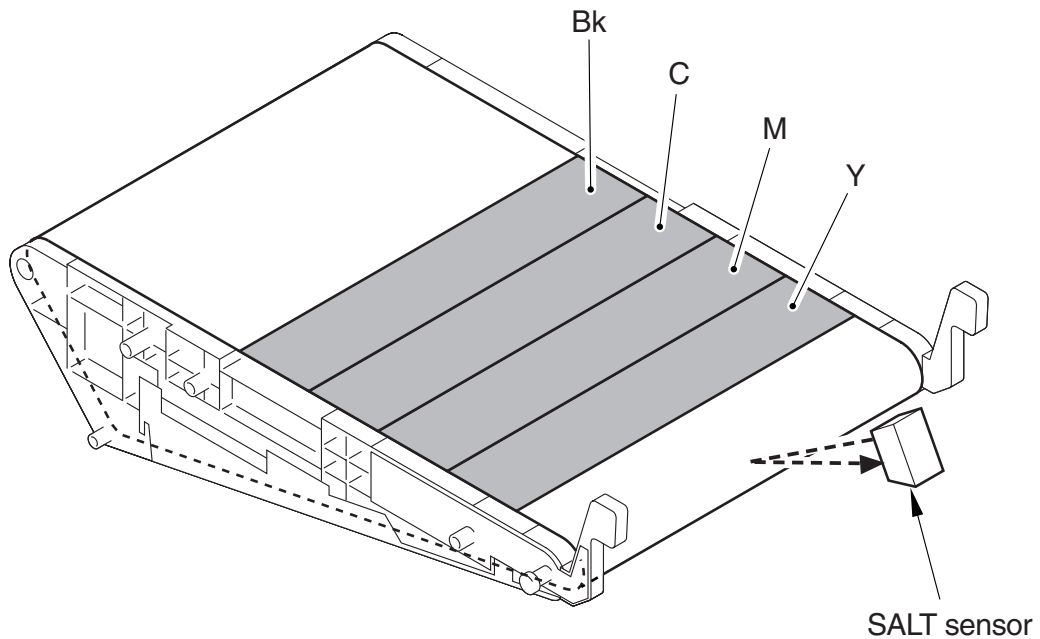

F04-203-02

Control Timing

See 2.2 ‘Automatic Control Timing.’

2.4 Discharge Current Level Control

- The machine controls the level of discharge current so as to ensure the optimum level in keeping with changes in temperature/humidity.
(The term “discharge current” refers to the current that occurs between the primary charging roller and the photosensitive drum.)
The current is controlled to a level that enables prevention of faulty images in a high humidity environment and, at the same time, permits collection of toner remaining from transfer to the developing assembly.

Operation

1. An AC bias is applied to the primary charging roller; the level of current occurring at the time is measured by the high-voltage PCB (HV1-SUB) and is sent to the CPU on the DC controller PCB as feedback.
 2. The roller is charged using the AC charging bias corrected by the CPU.
- If thick paper, special paper, or transparency is used, the frequency of the AC bias applied to the primary charging roller is halved.

Timing of Control

See 2.2 “Automatic Control Timing.”

2.5 ATVC Control (transfer bias level correction)

The ATVC control mechanism is used to determine the optimum level of transfer voltage for transfer of images from the photosensitive drum to the ITB, and from the ITB to paper. The level of transfer voltage is corrected in relation to changes in temperature/humidity, deterioration of rollers, and types of paper.

Description of Control

1. A reference voltage is applied to the transfer roller, and the level of current that occurs in response is checked by the high-voltage PCB and communicated to the CPU on the DC controller PCB as feedback.
2. The machine executes transfer using a transfer voltage which is the result of correction by the CPU.

Item	Description
Primary transfer	Applies a reference voltage to the primary charging roller. Uses the high-voltage PCB (HV-2) to check the level of current, and the result is fed back to the CPU for determination of the optimum level.
Secondary transfer	Applies a reference voltage to the secondary transfer external roller. Uses the high-voltage PCB (HV-3) to check the level of current, and the result is fed back to the CPU for determination of the optimum level.

T04-205-01

Timing of Control

See 2.2 "Timing of Auto Control Mechanisms."

2.6 PASCAL Control (image gradation)

The PASCAL control mechanism is used to stabilize gradation characteristics of images on paper. It makes up for the changes in gradation occurring in response to changes in temperature/humidity or as the machine is used over time.

- PASCAL Control for Half-Speed

The mechanism is used to correct the changes in the gradation characteristics that otherwise would occur when thick paper, special paper, or transparency is used. The test print used for the mechanism is the same as the test print used for plain paper.

Description of Control

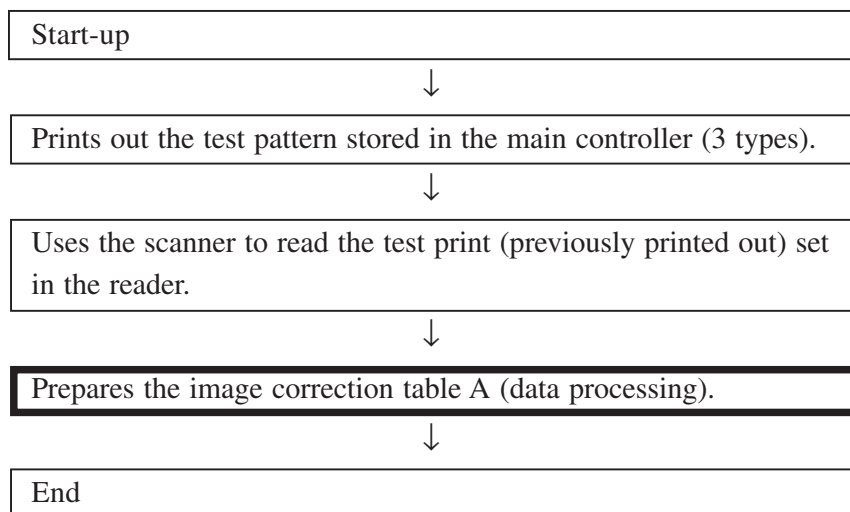

Timing of Control

- Service Person Interaction

The mechanism is executed when 'full correction' is executed while auto gradation correction is under way in user mode.



REF.

Differences Among 3 Test Patterns

- **Test Print 1**
It shows 64 gradations expressed by means of error diffusion processing, which is not subject to moire and, therefore, used in text/photo/map, print photo, and text mode.
- **Test Print 2**
It shows 64 gradations expressed by means of screening with a low number of lines, which is suitable for the expression of gradation and, therefore, is used for print film photo mode and when priority is placed on PDL.
- **Test Print 3**
It shows 64 gradations expressed by means of screening with a high number of lines, which is suitable for the achievement of a high resolution and is, therefore, used when priority is placed on PDL resolution.



Test Print

F04-206-01

2.7 SALT-Dmax Control (development characteristics correction)

This mechanism is used to stabilize the maximum resolution on the intermediate transfer belt (ITB). It is used to make up for changes in the maximum density (Dmax), changes in response to deterioration in developer or the drum, changes in temperature/humidity, or changes occurring as the machine is used over time.

Description of Control

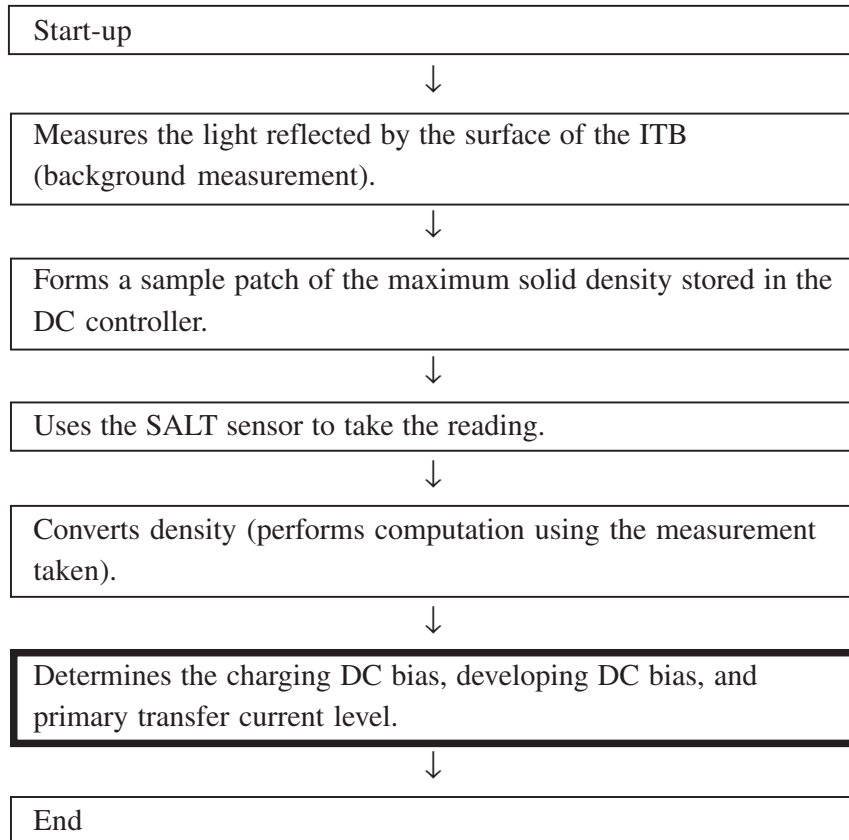

Timing of Control

1. Automatic
See 2.2 "Timing of Auto Control Mechanisms."
2. Service Person Interaction
The mechanism is executed when 'full correction' or 'quick correction' of auto gradation correction is under way in user mode.

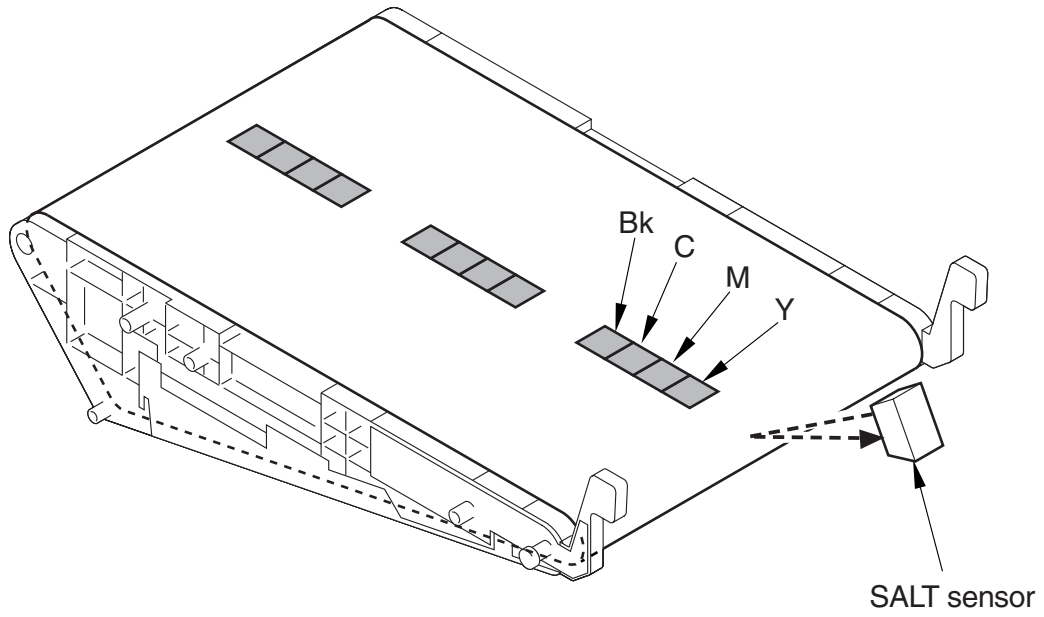

F04-207-01

2.8 SALT-Dhalf Control (development characteristics correction)

The SALT-Dhalf control mechanism is used to stabilize the gradation of images on the ITB. It makes up for the changes in gradation characteristics that occur in response to the deterioration in developer or photopositive drum, changes in temperature/humidity, and changes that occur as the machine is used over time.

- Gradation Density Control for Half Speed

The control mechanism is used to make up for the changes in the gradation in images when thick paper, special paper, or transparency is used.

When the mechanism is enabled in service mode, it is activated when auto control is executed.

The time it takes is about double the time taken when plain paper is used.

Description of Control

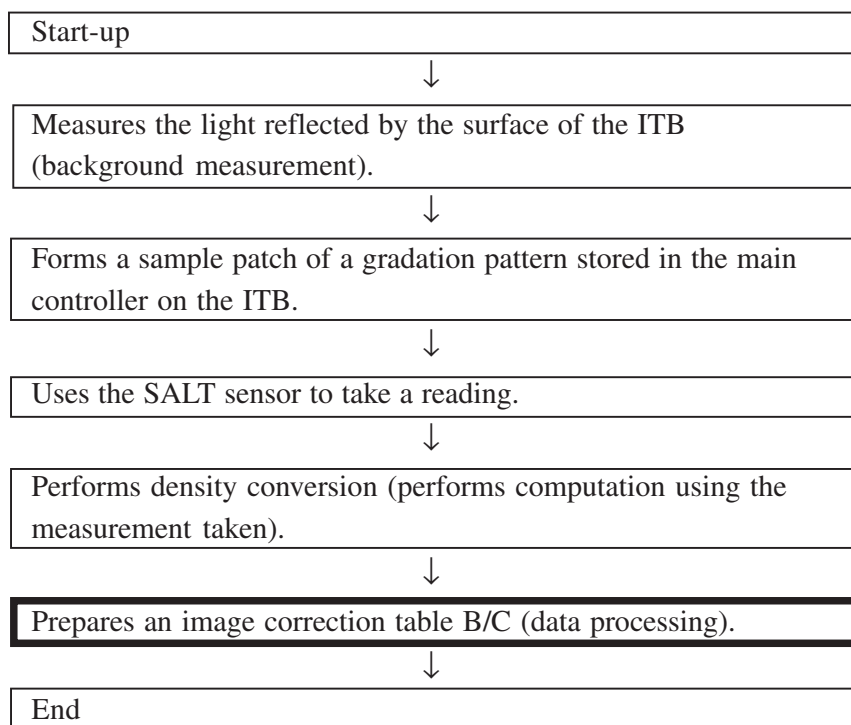

Timing of Control

1. Automatic

See 2.2 “Timing of Automatic Control Mechanism.”

2. Non-Automatic

The mechanism is executed when ‘full correction’ or ‘quick correction’ is under way in user mode.



COPIER>OPTION>BODY>CAL-SW

Use it to change the conditions that initiate automatic control.

default: 0 (disable gradation density control for half speed)

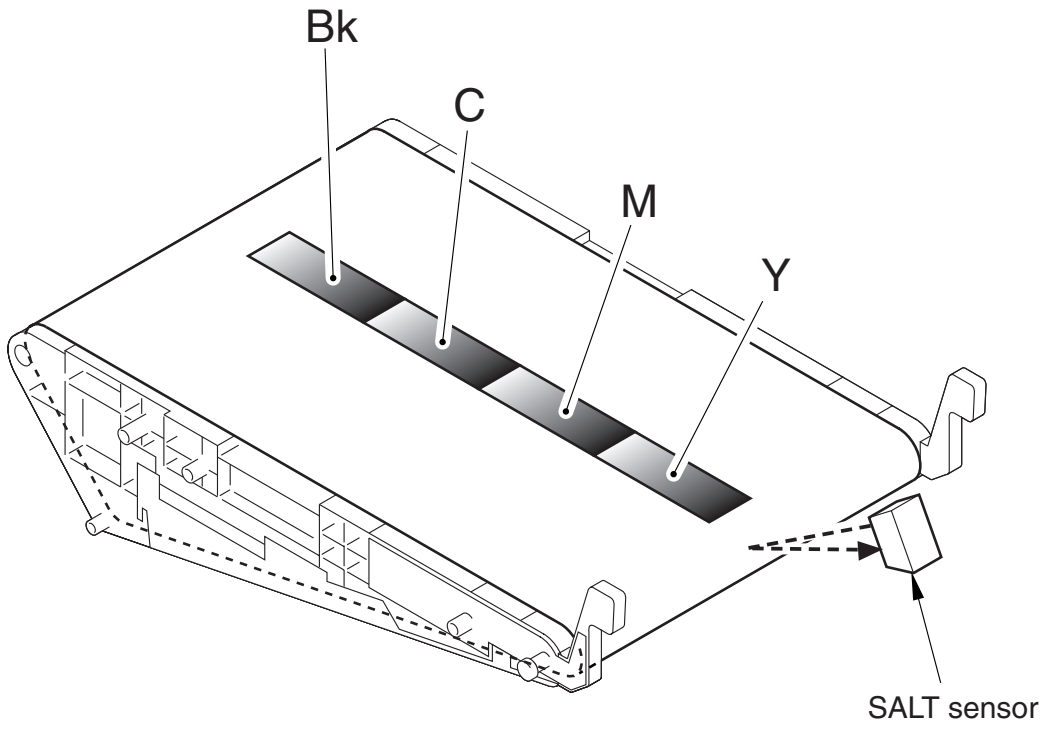

F04-208-01

2.9 Auto Gradation Control

Outline

The auto gradation control mechanism is used to correct image gradation by correcting the laser output so as to obtain ideal gradation characteristics.

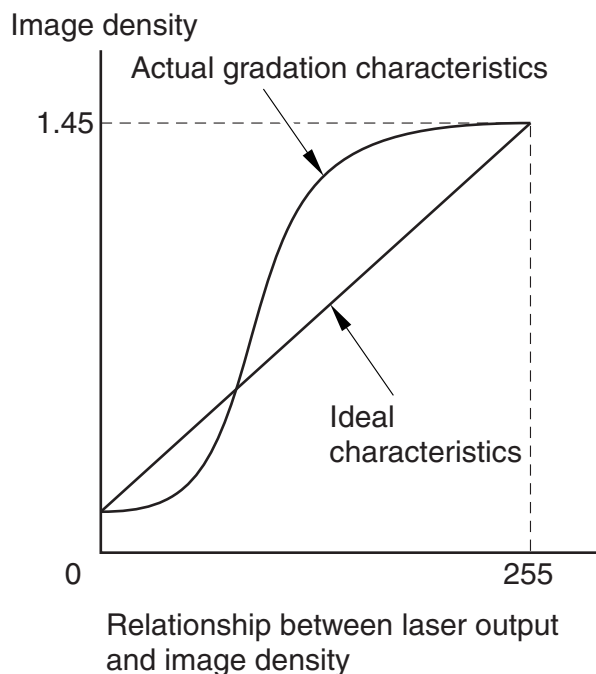

F04-209-01

Full Correction: The machine knows the actual gradation characteristics based on the 64-gradation density data collected from the scanner.

Quick Correction: The machine knows the actual gradation characteristics based on the 9-gradation density data.

User Mode

The machine uses 2 types of auto gradation correction mechanisms, combining the best mechanisms to suit individual requirements.

	Full correction	Quick correction
Description	<div style="border: 1px solid black; padding: 5px; margin-bottom: 5px;">Start up</div> <div style="text-align: center;">↓</div> <div style="border: 1px solid black; padding: 5px; margin-bottom: 5px;">SALT-Dmax control (determines developing DC, charging DC, primary current levels)</div> <div style="text-align: center;">↓</div> <div style="border: 1px solid black; padding: 5px; margin-bottom: 5px;">PASCAL control (prepares image correction table A)</div> <div style="text-align: center;">↓</div> <div style="border: 1px solid black; padding: 5px; margin-bottom: 5px;">Image position correction</div> <div style="text-align: center;">↓</div> <div style="border: 1px solid black; padding: 5px; margin-bottom: 5px;">SALT-Dhalf control (prepares image correction table B)</div> <div style="text-align: center;">↓</div> <div style="border: 1px solid black; padding: 5px; margin-bottom: 5px;">End</div>	<div style="border: 1px solid black; padding: 5px; margin-bottom: 5px;">Start up</div> <div style="text-align: center;">↓</div> <div style="border: 1px solid black; padding: 5px; margin-bottom: 5px;">SALT-Dmax control (determines developing DC, charging DC, and primary transfer levels)</div> <div style="text-align: center;">↓</div> <div style="border: 1px solid black; padding: 5px; margin-bottom: 5px;">Image position correction</div> <div style="text-align: center;">↓</div> <div style="border: 1px solid black; padding: 5px; margin-bottom: 5px;">SALT-Dhalf control (prepares image correction table C)</div> <div style="text-align: center;">↓</div> <div style="border: 1px solid black; padding: 5px; margin-bottom: 5px;">End</div>
Image correction table for use at time of image formation	Image correction table A	Table prepared by the result of including the contents of the table A to the result of compari- son between image correction tables B and C
Characteristics	A test print must be printed and read by the machine.	The machine does not use (print) a test print.

T04-209-01

3 Drum Unit (D-UNIT)

3.1 Outline of the Drum Unit

The drum unit consists of the developing assembly, photosensitive drum, auxiliary brush, and charging mechanism. As many as 4 units are used (Y, M, C, Bk), and all of them have the same construction.

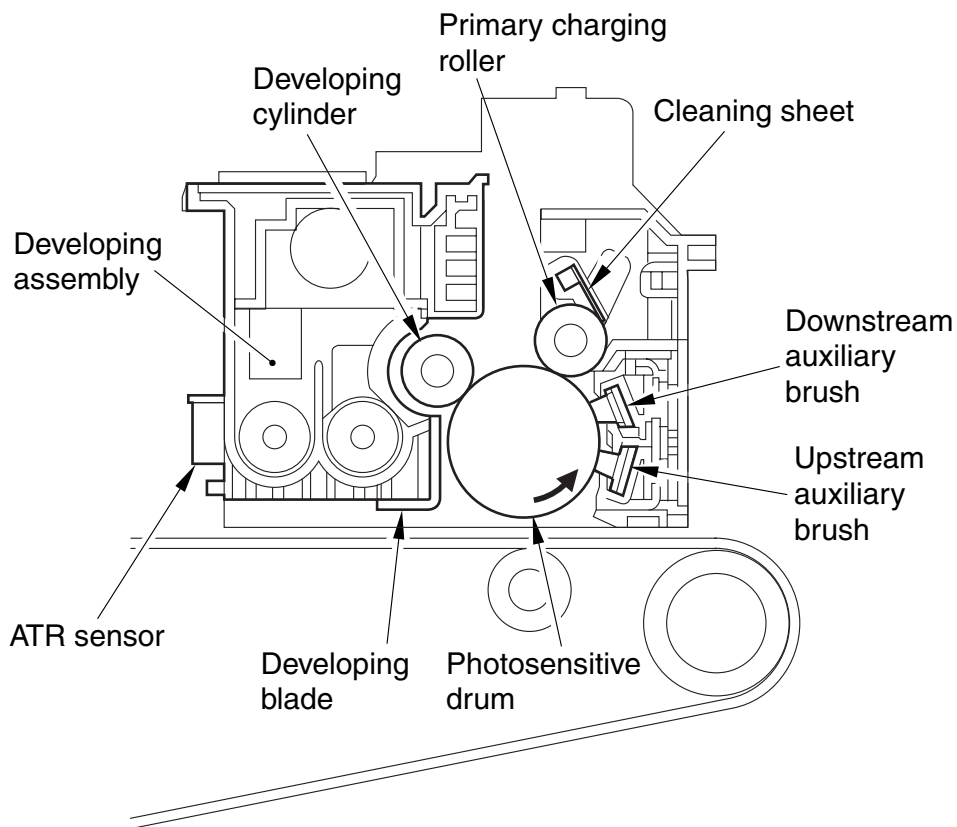

F04-301-01

3.2 Controlling the Drive of the Drum Unit (D-UNIT)

Parts	Source of drive	Remarks
Developing cylinder	Developing motor (M2 through M15)	driven through gears
Toner stirring screw	Developing motor (M2 through M15)	driven through gears
Charging roller	Linked to photosensitive drum	
Photosensitive drum	Drum ITB motor (M1)	driven through gears
Auxiliary brush, cleaning sheet	Drum ITB motor (M1)	(reciprocating movement in drum axial direction)

T05-302-01

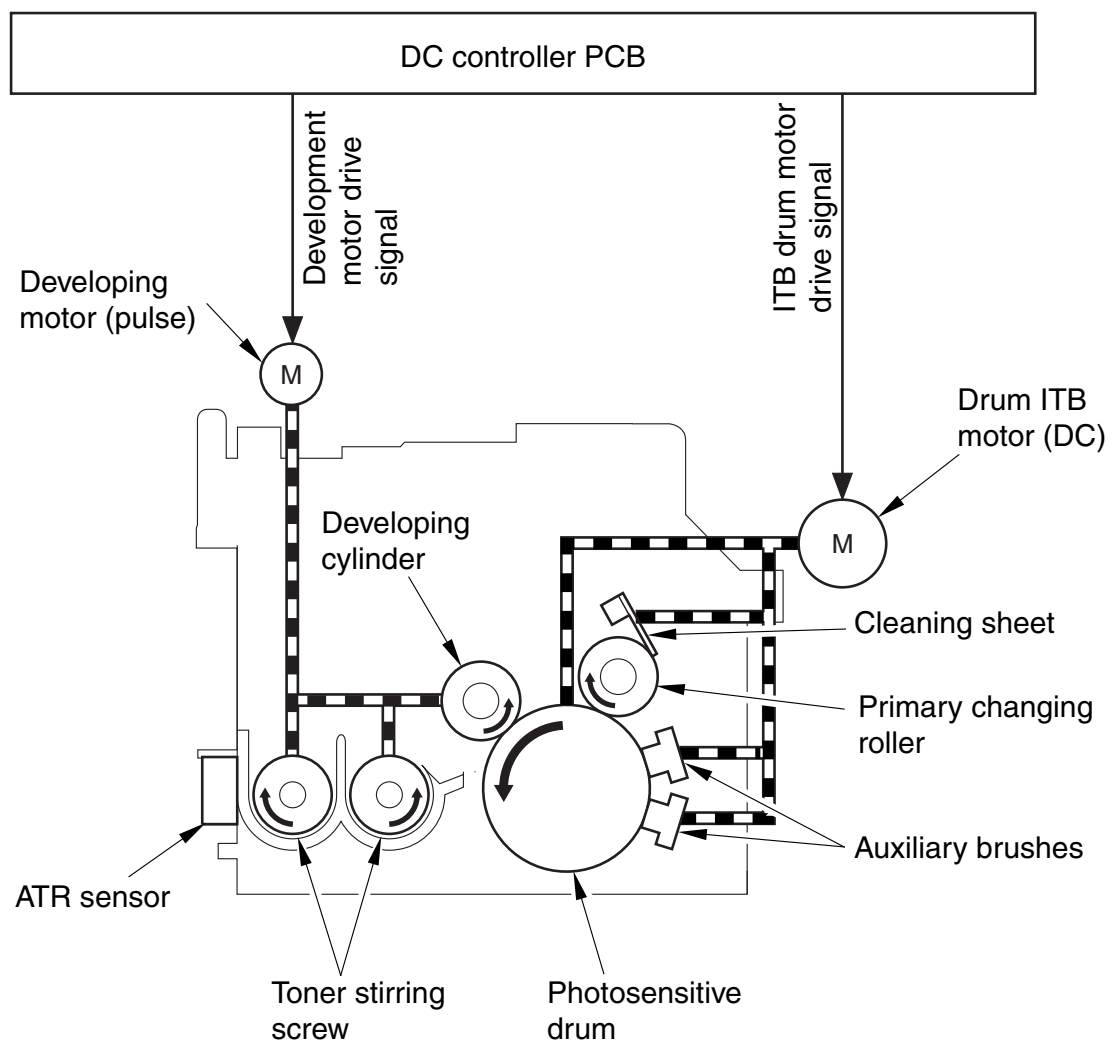

F04-302-01

3.3 Developing Assembly

3.3.1 Construction of the Developing Assembly

Outline and Uses

1. turning latent static image into visible image (development)
2. collecting residual toner from photosensitive drum
 - eliminates the need for a cleaning mechanism for the photosensitive drum

Component

Developing cylinder	<ul style="list-style-type: none"> • deposits toner on the photosensitive drum. • collects toner from the photosensitive drum coming from upstream
Developing blade	<ul style="list-style-type: none"> • serves to coat the developing cylinder with a uniform layer of developer
Toner stirring screw	<ul style="list-style-type: none"> • stirs the toner and the developer inside the developing assembly (thus, charging the toner to a negative potential).
ATR sensor	<ul style="list-style-type: none"> • detects the amount (concentration of toner) inside the developing assembly.

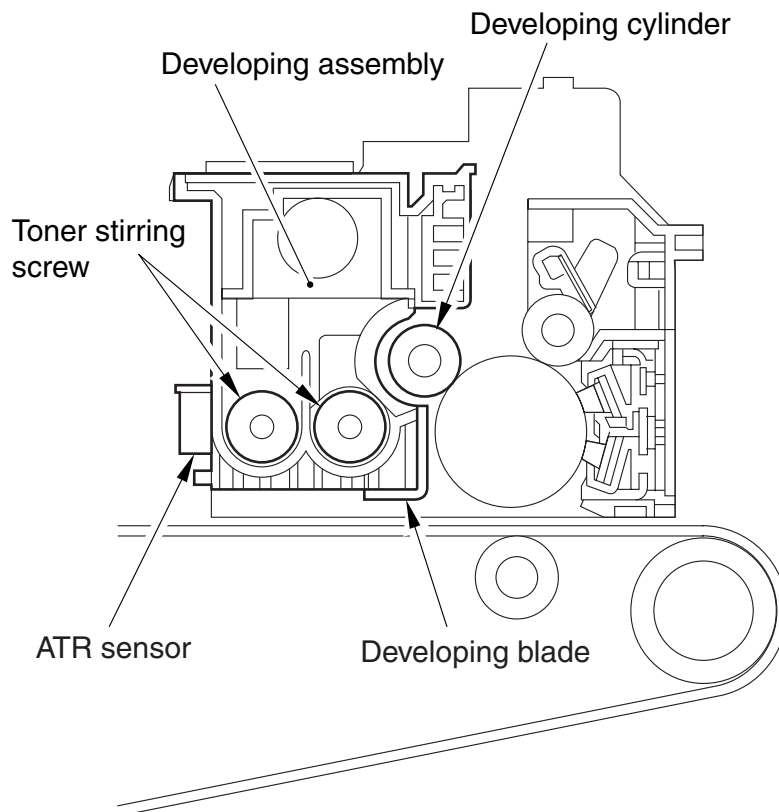

F04-303-01

3.3.2 Controlling the Developing Bias

- 1) AC Component
fixed; used to increase the density of output images.
- 2) DC Component
output suited to the reading of the environment sensor/SALT sensor;
changes the median voltage of the AC bias to adjust the image density

a-1. Route of the Developing Bias

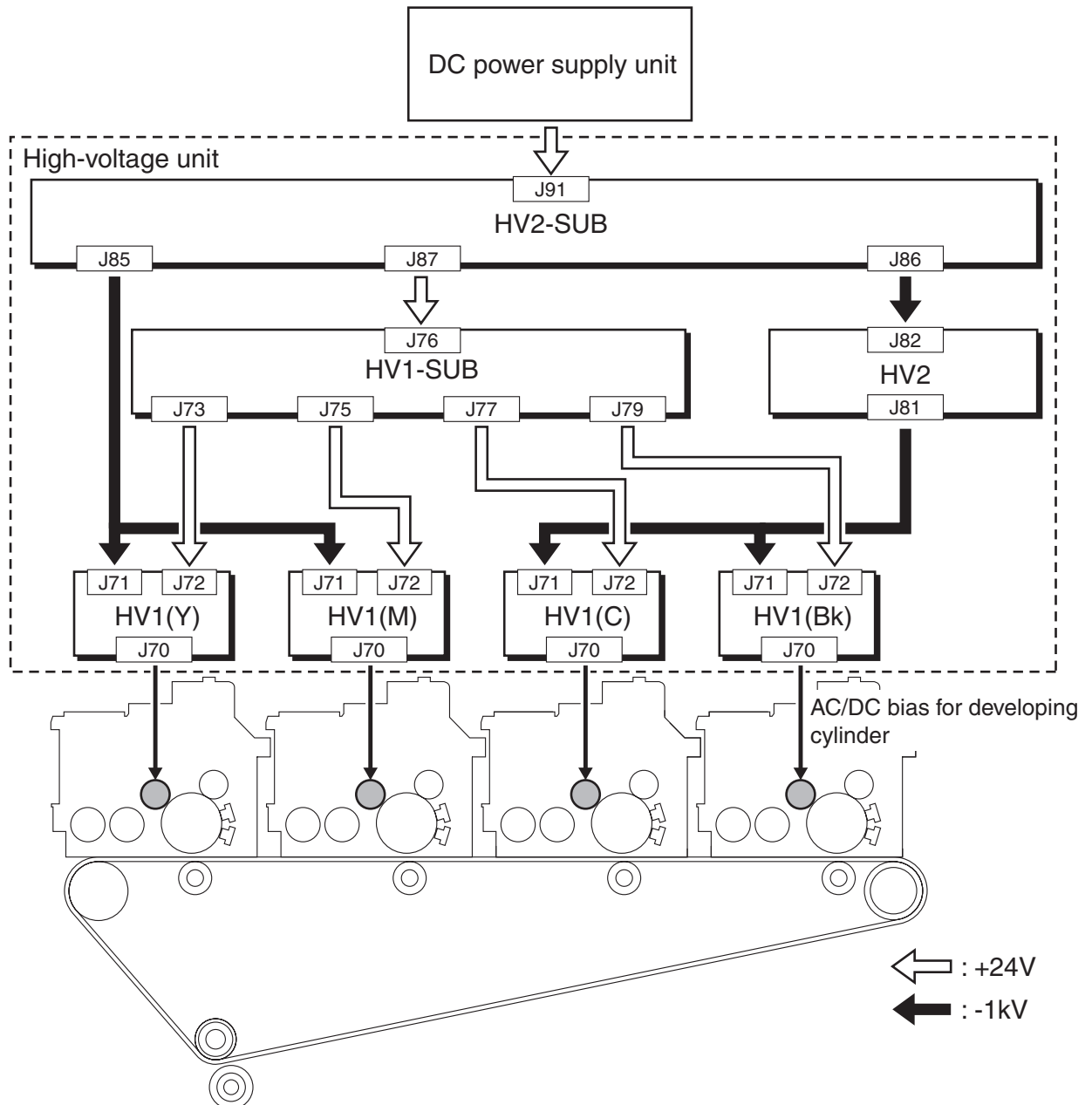

F04-303-02

a-2. Route of the Developing Cylinder Control Signal

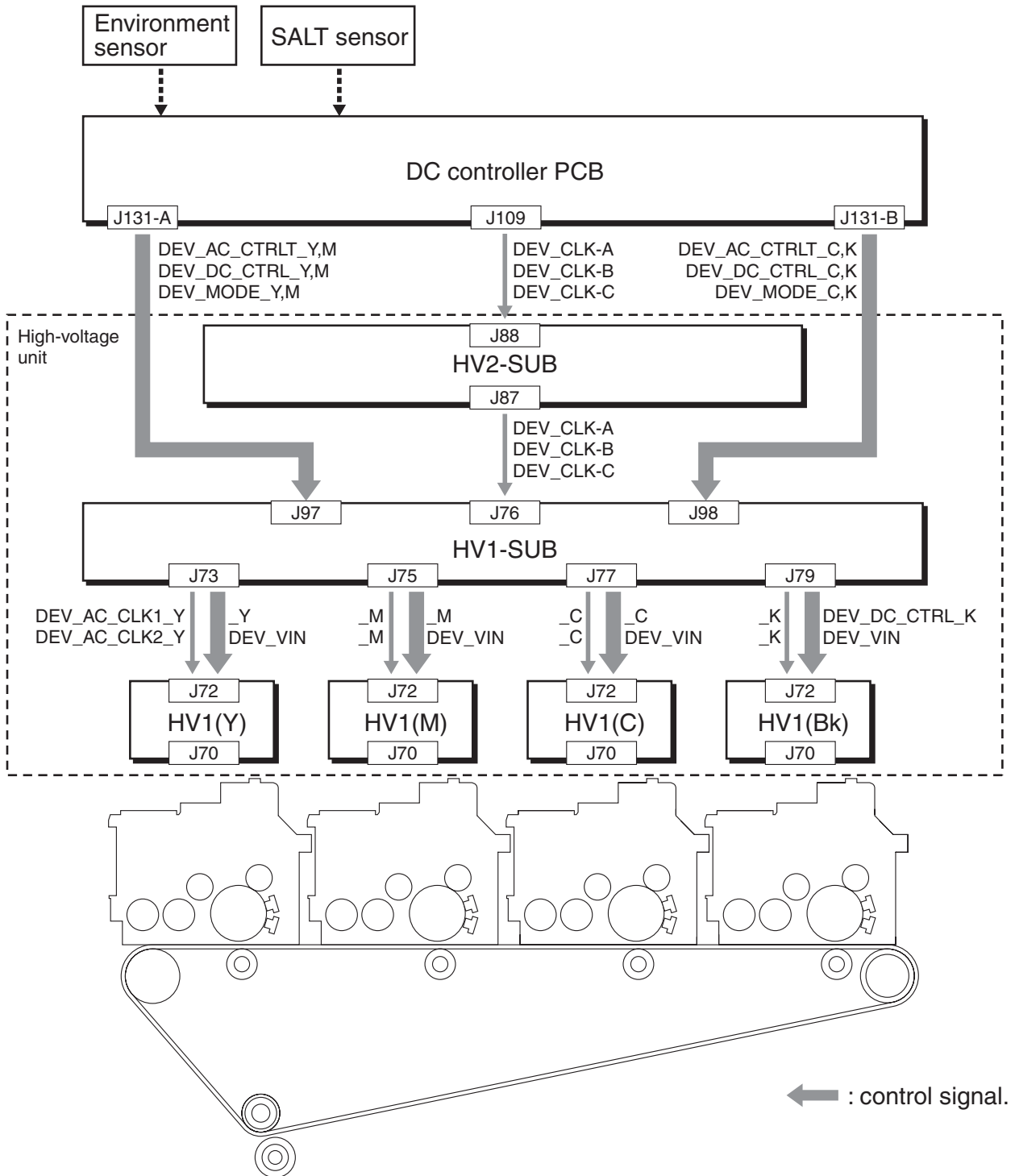

F04-303-03

3.4 Auxiliary Brush

3.4.1 Construction of the Auxiliary Brush

Outline and Uses

1. removes charges from the photosensitive drum; charges residual toner
2. controls the polarity of residual toner
 - thereby preventing adhesion of toner to the primary charging roller
 - thereby eliminating the need for a cleaning mechanism for the photosensitive drum

Component

Upstream auxiliary brush	<ul style="list-style-type: none"> • removes charges from the photosensitive drum. (in preparation for the next image formation session, the latent static image from the previous session is removed) • charges the residual toner to a positive potential. (to increase the effects of charging by the downstream brush as part of the upcoming operation)
Downstream auxiliary brush	<ul style="list-style-type: none"> • charges the photosensitive drum to a negative potential. • charges the residual toner to a negative potential. (to facilitate collection by the developing assembly)

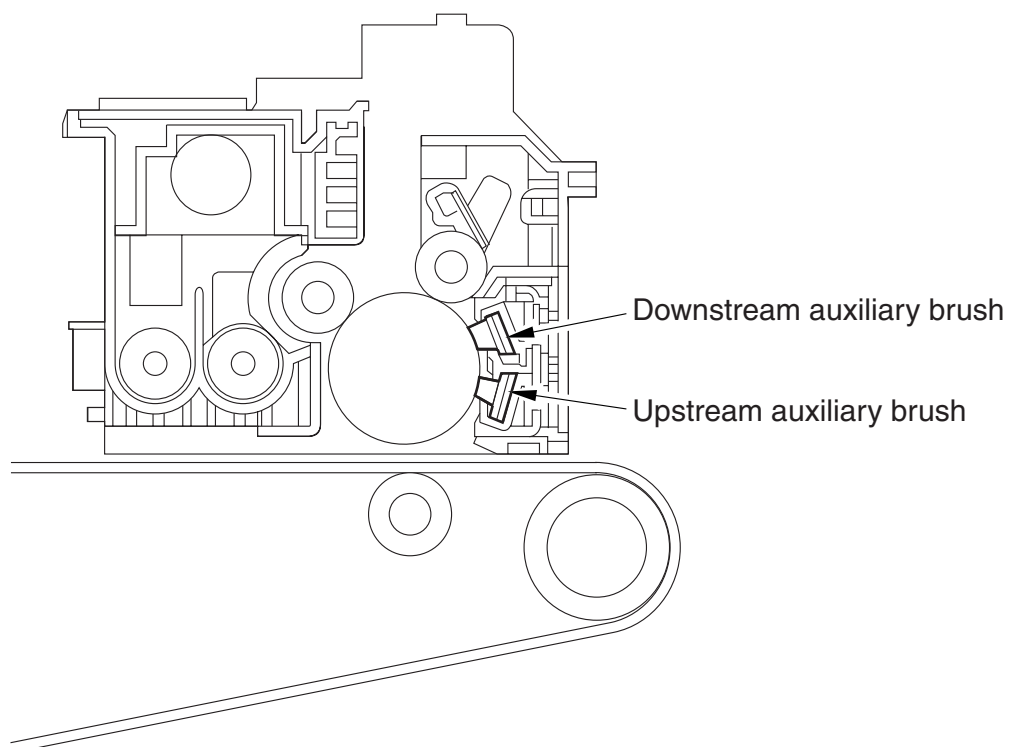

F04-304-01

3.4.2 Controlling the Auxiliary Bias

AC Component: level of output suited to the reading of the environment sensor. (upstream auxiliary brush)

DC Component: level of output suited to the reading of the environment sensor. (upstream/downstream auxiliary brush)

b-1. Route of the Upstream Auxiliary Brush Bias

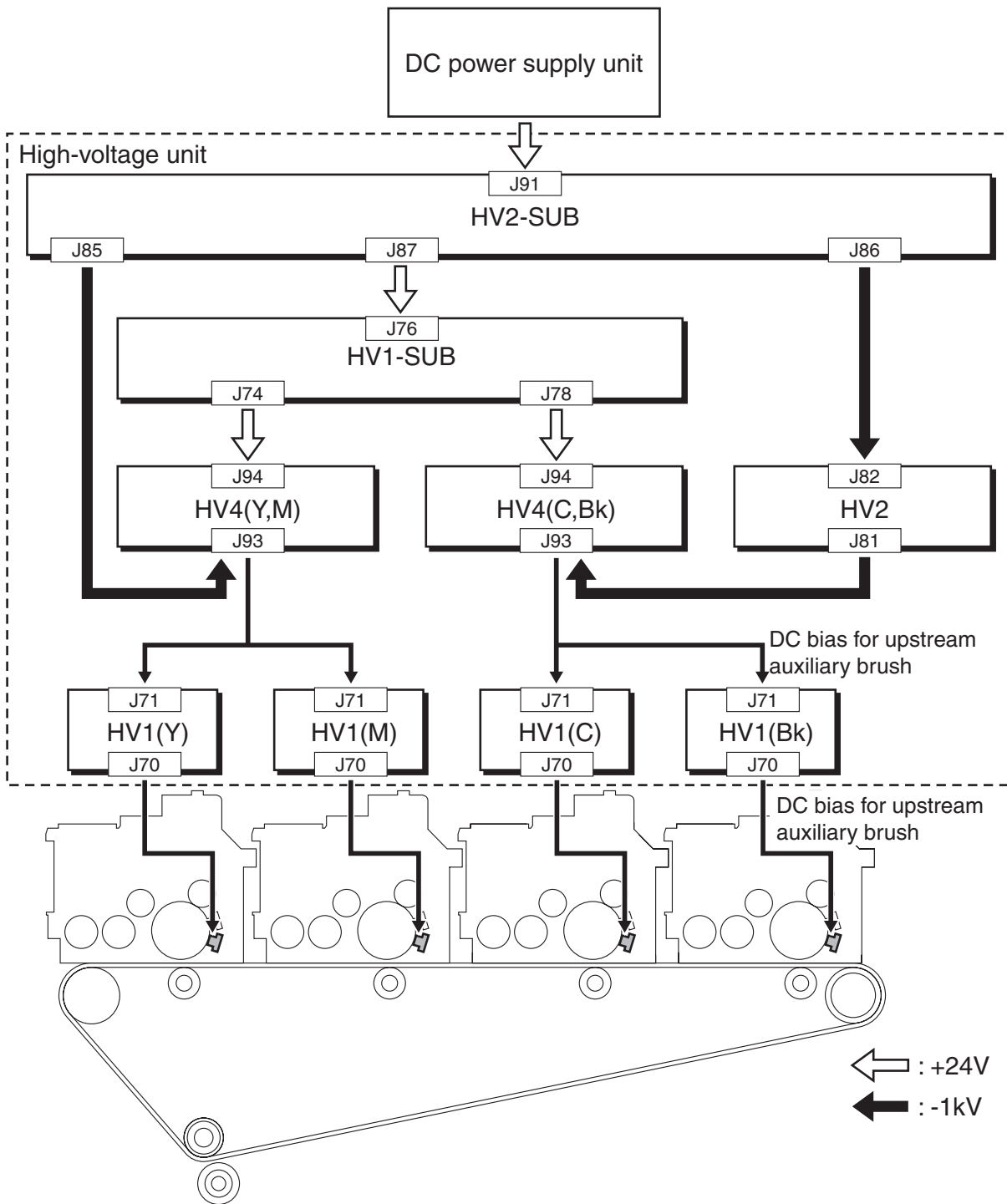

F04-304-02

b-2. Route of the Upstream Auxiliary Brush Bias Control Signal

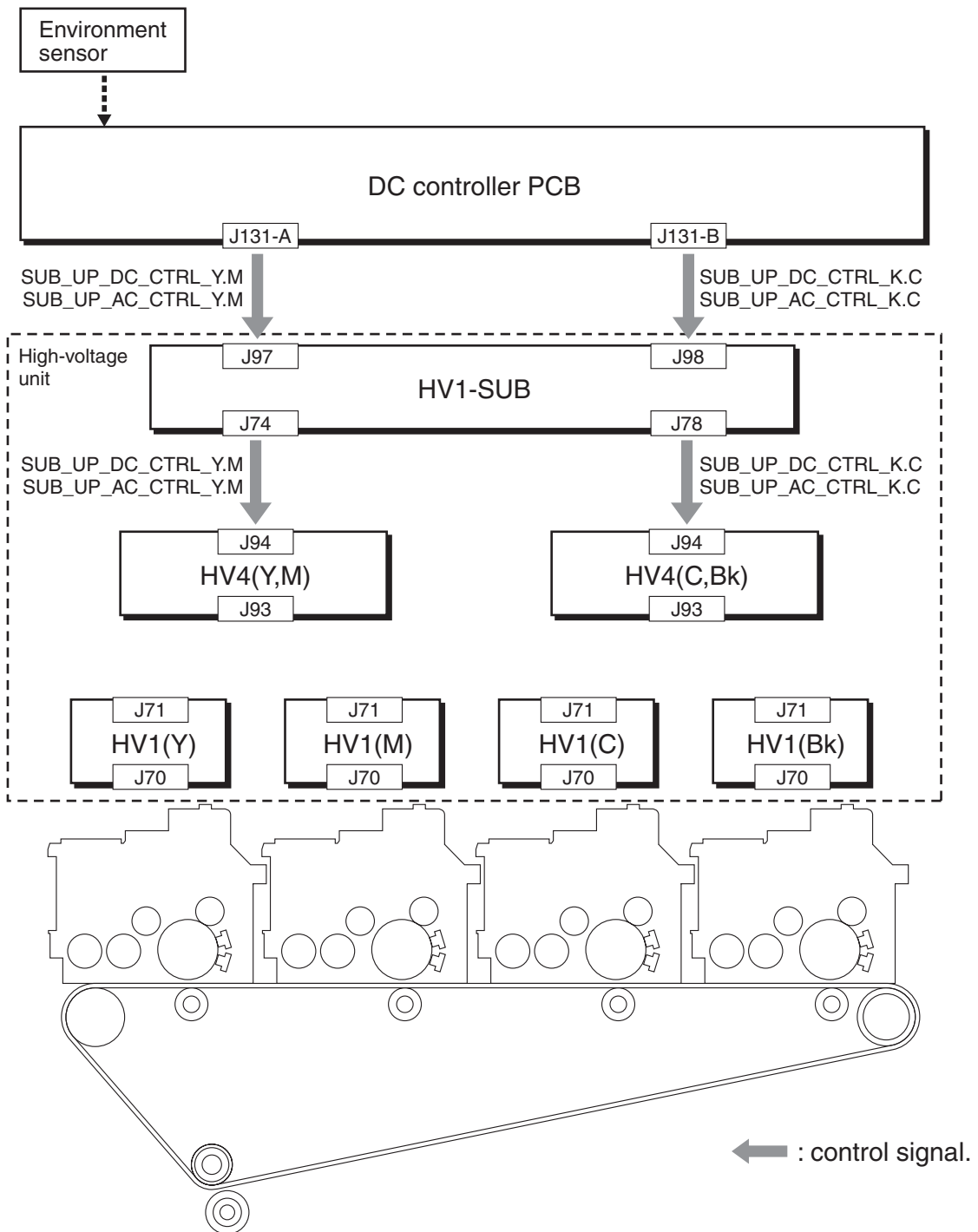

F04-304-03

c-1. Route of the Downstream Auxiliary Brush Bias

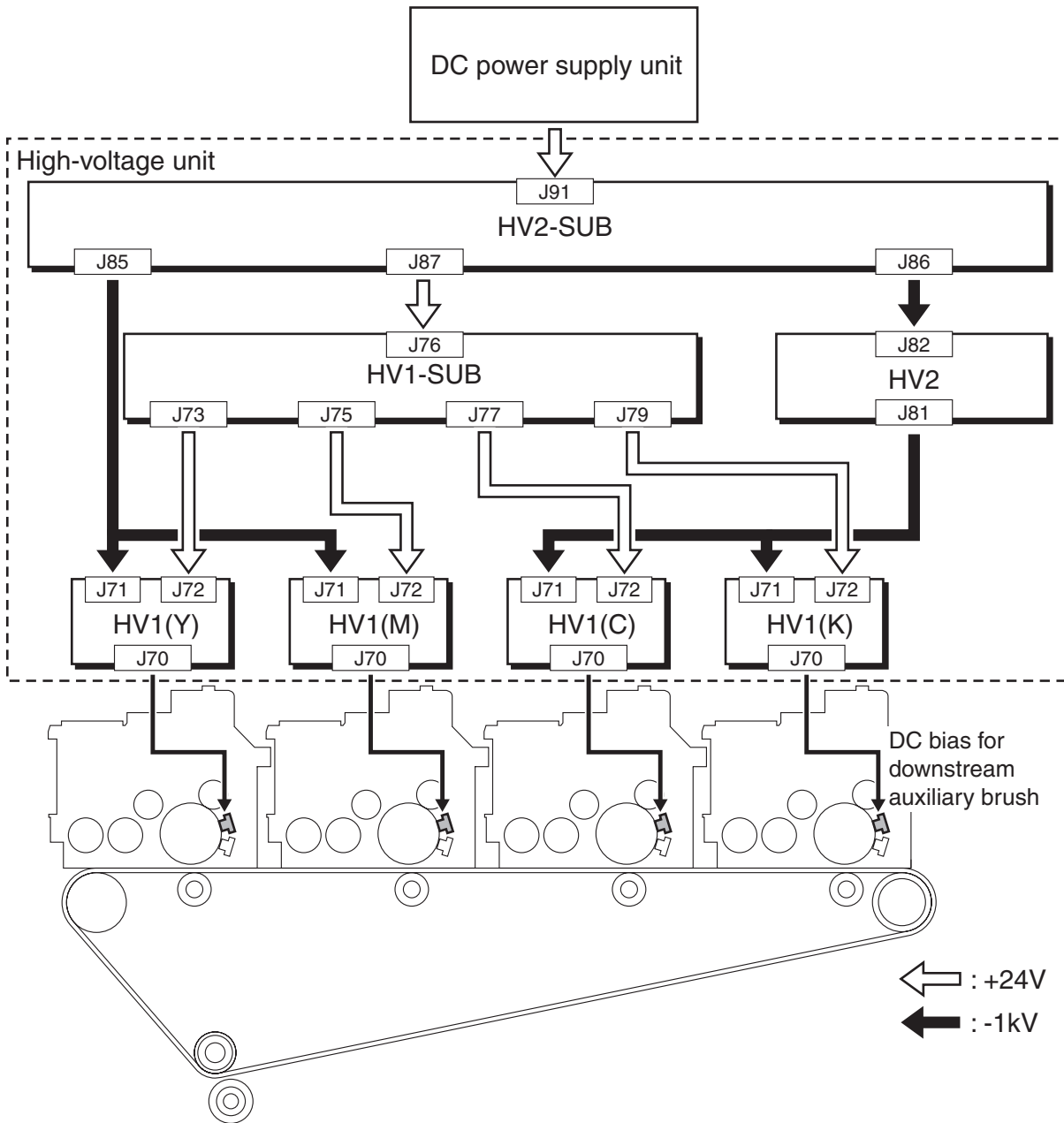

F04-304-04

c-2. Route for the Downstream Auxiliary Brush Bias Control Signal

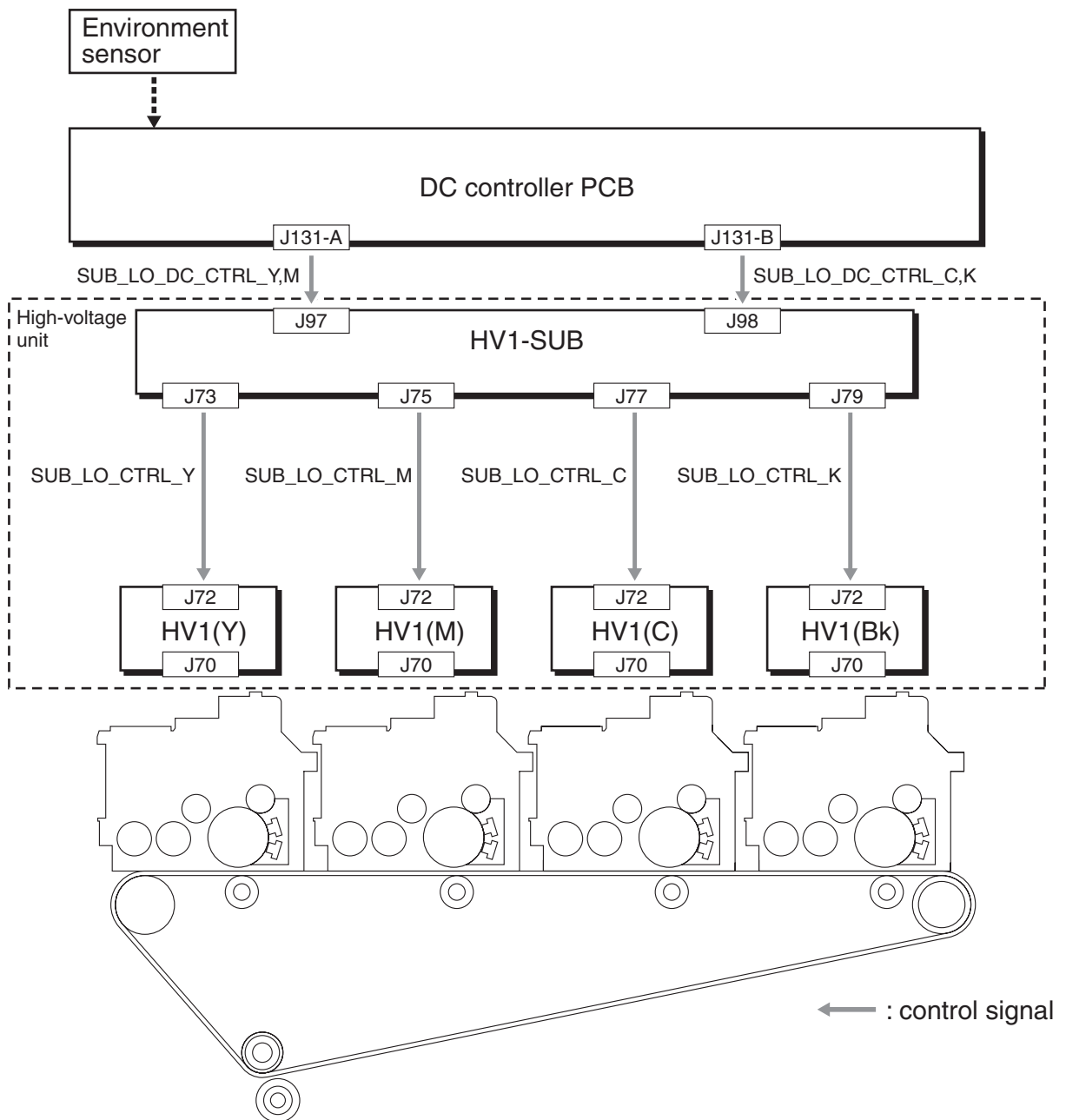

F04-304-05

3.5 Charging Mechanism

3.5.1 Construction of the Charging Mechanism

Outline and Uses

1. charging the photosensitive drum
2. controlling the polarity of residual toner by the cleaning sheet
 - thus preventing the adhesion of toner to the primary charging roller
 - thus eliminating the need for a cleaning mechanism for the photosensitive drum

Component

Primary charging roller	<ol style="list-style-type: none"> 1. in preparation for the next image formation session, the photosensitive drum is evenly charged to a negative potential. 2. returns the toner charged to a negative potential to the photosensitive drum (for collection in the developing assembly).
Primary charging roller cleaning sheet	<ul style="list-style-type: none"> • charges residual toner to a negative potential by friction (thereby returning the toner to the photosensitive drum).

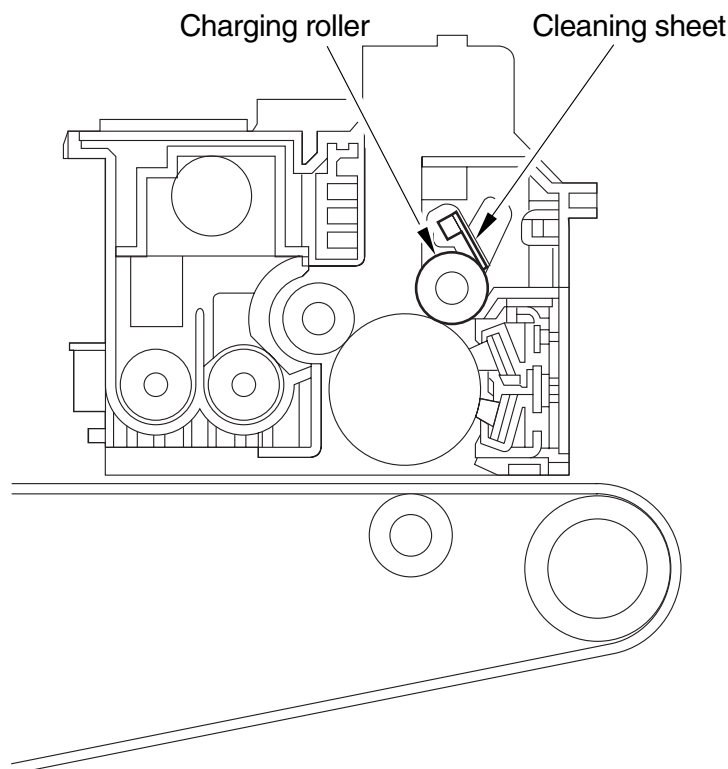

F04-305-01

3.5.2 Controlling the Charging Bias

AC Component: level of output suited to discharge current control

DC Component: level of output suited to the reading of the environment sensor/SALT sensor

d-1. Route of the Primary Charging Bias

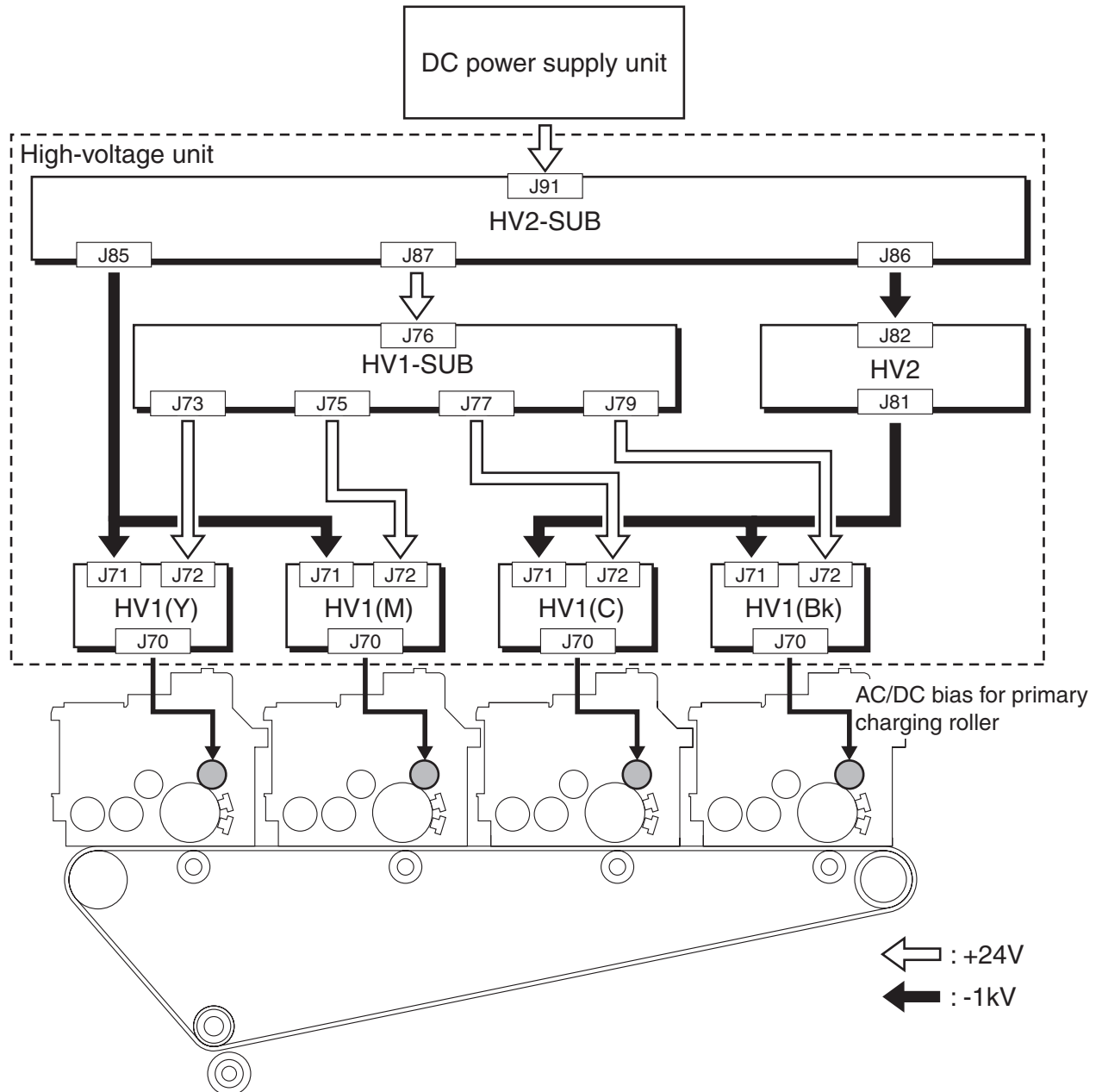

F04-305-02

d-2. Route for the Primary Charging Bias Control Signal

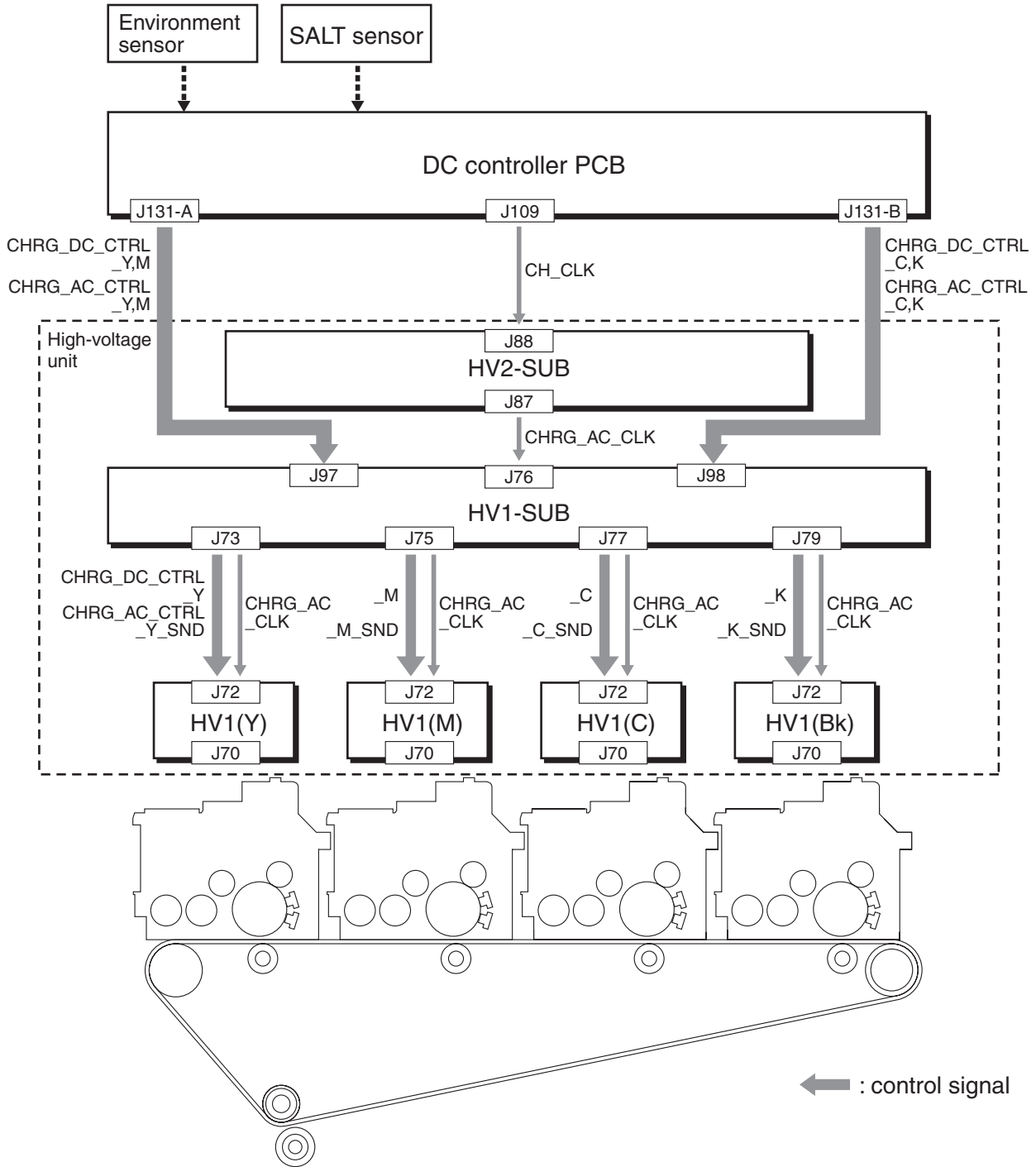

F04-305-03

4 Toner Container

4.1 Outline of the Toner Container

The toner container consists of toner, stirring blade, and toner feedscrew; as many as 4 containers are used (Y, M, C, Bk), and all of them are of the same construction.

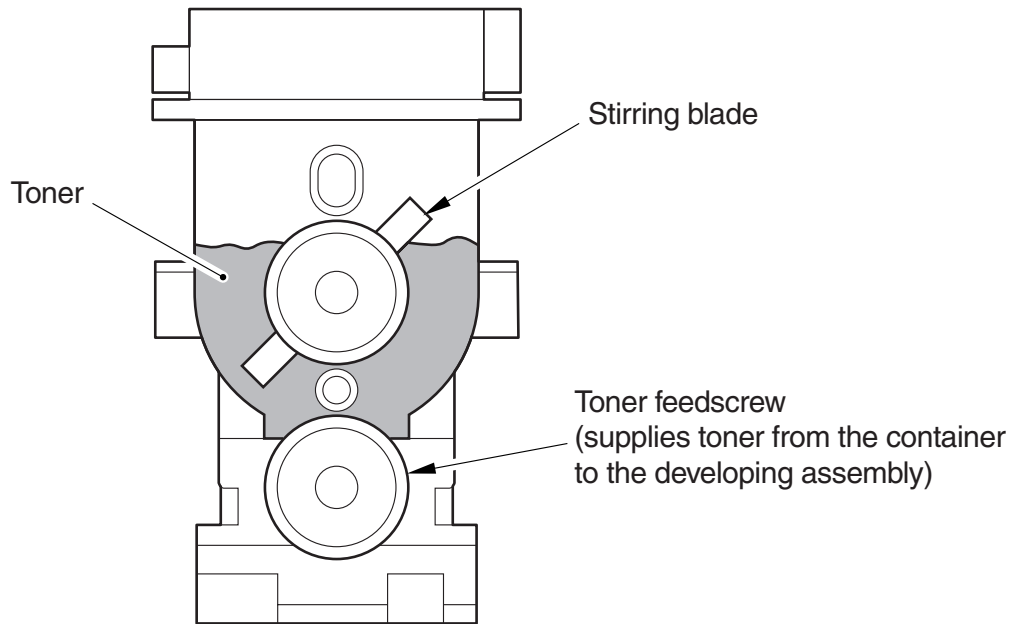

F04-401-01

4.2 Controlling the Toner Container Drive

Part	Source of drive	Remarks
Stirring blade	Toner container motor (M20 to 23)	driven through gears
Toner feedscrew	Toner container motor (M20 to 23)	driven through gears

T05-402-01

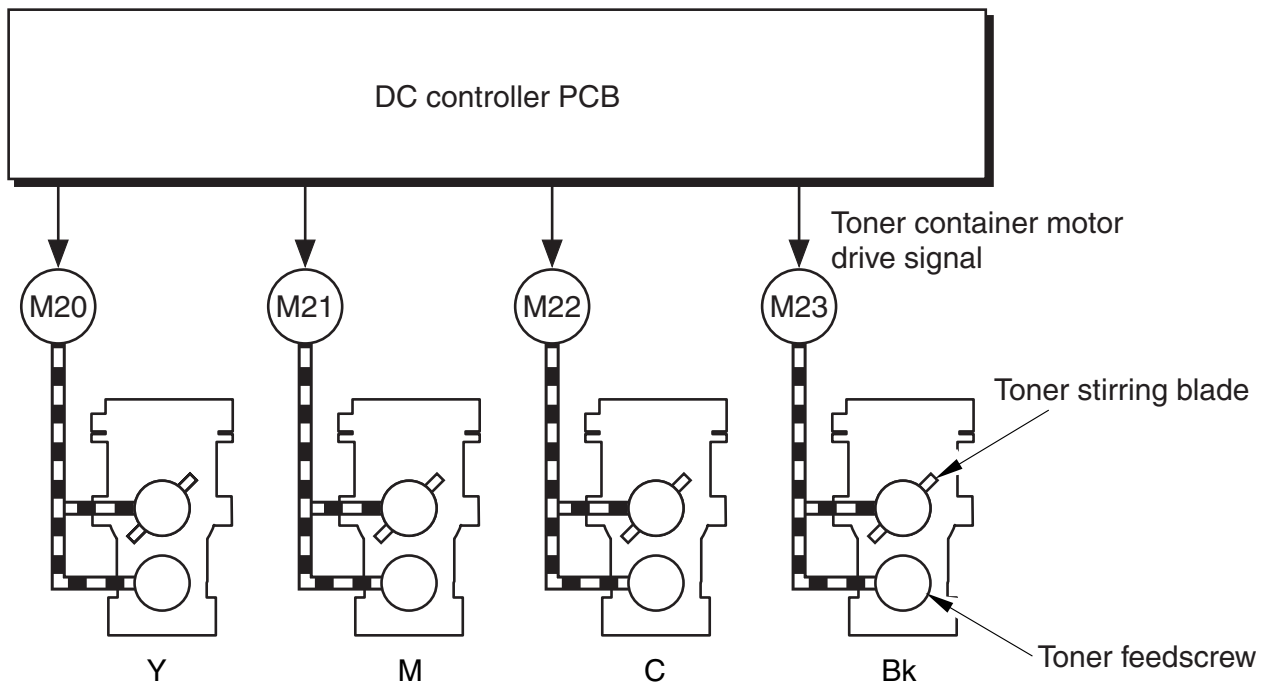

F04-402-01

4.3 Checking the Level of Toner

The machine checks the level of toner using the following sensors:

Developing assembly	ATR sensor
	<p>magnetic sensor</p> <p>Description</p> <p>checks the concentration of toner inside the developing assembly. relies on the fact that a change in the ratio between carrier (magnetic) and toner (non-magnetic) changes the force of magnetism. detects changes to identify the level of toner.</p>
	SALT Sensor
	<p>photo sensor</p> <p>Description</p> <p>checks the sample toner image formed on the intermediate transfer belt (ITB) at such times as programmed. checks the density of the toner image after development.</p>
Toner container	Toner feedscrew rotation sensor
	<p>photo interrupter</p> <p>Description</p> <p>checks the number of revolutions made by the toner feedscrew. the amount of toner supplied to the developing assembly made by a single rotation of the feedscrew is constant, enabling the computation of the level of remaining toner with reference to the number of revolutions.</p>

T04-403-01

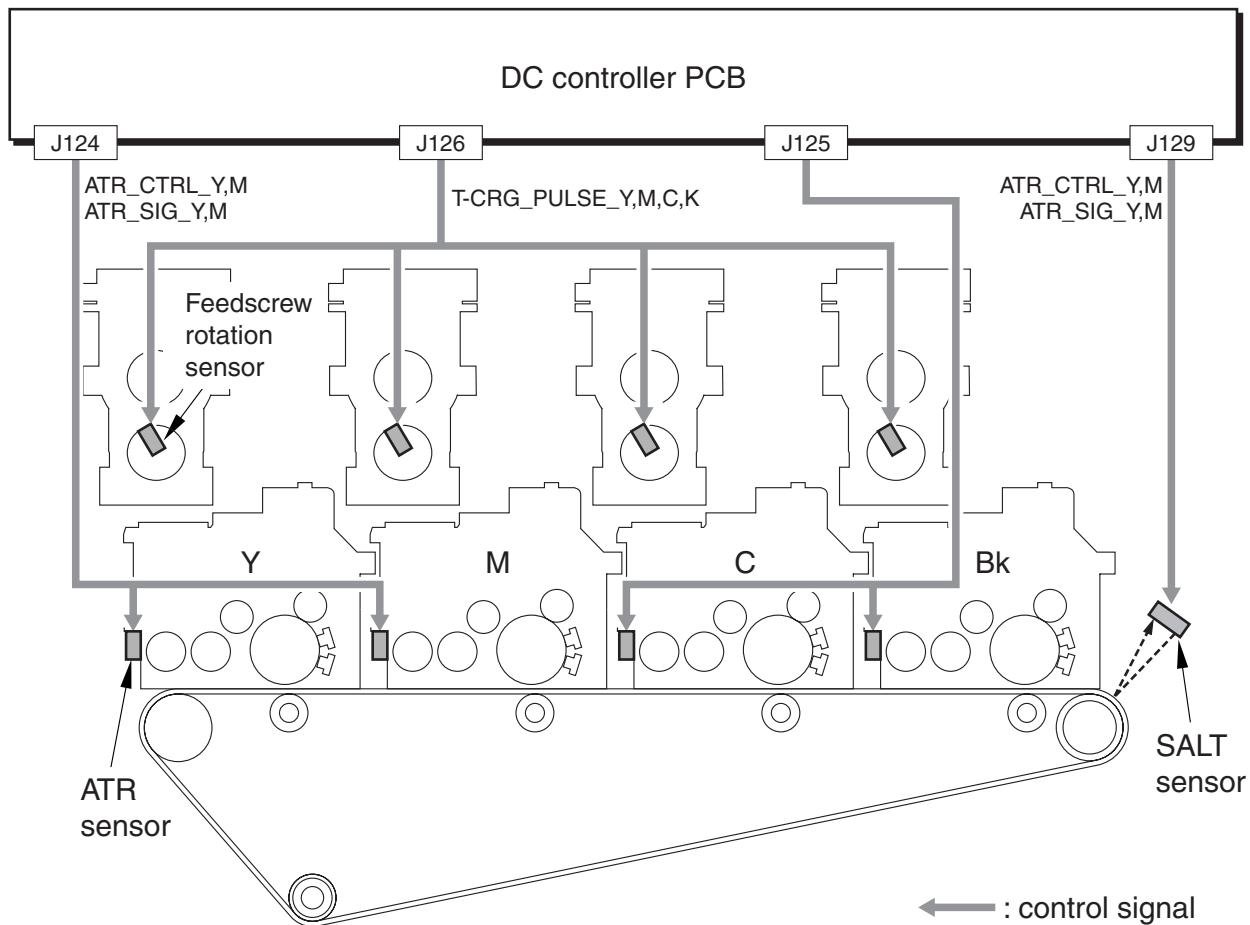

F04-403-01

4.4 Controlling the Supply of Toner

1. Developing Assembly

If the ATR sensor identifies a shortage of toner inside the developing assembly, the machine starts control of toner supply from the toner container to the developing assembly.

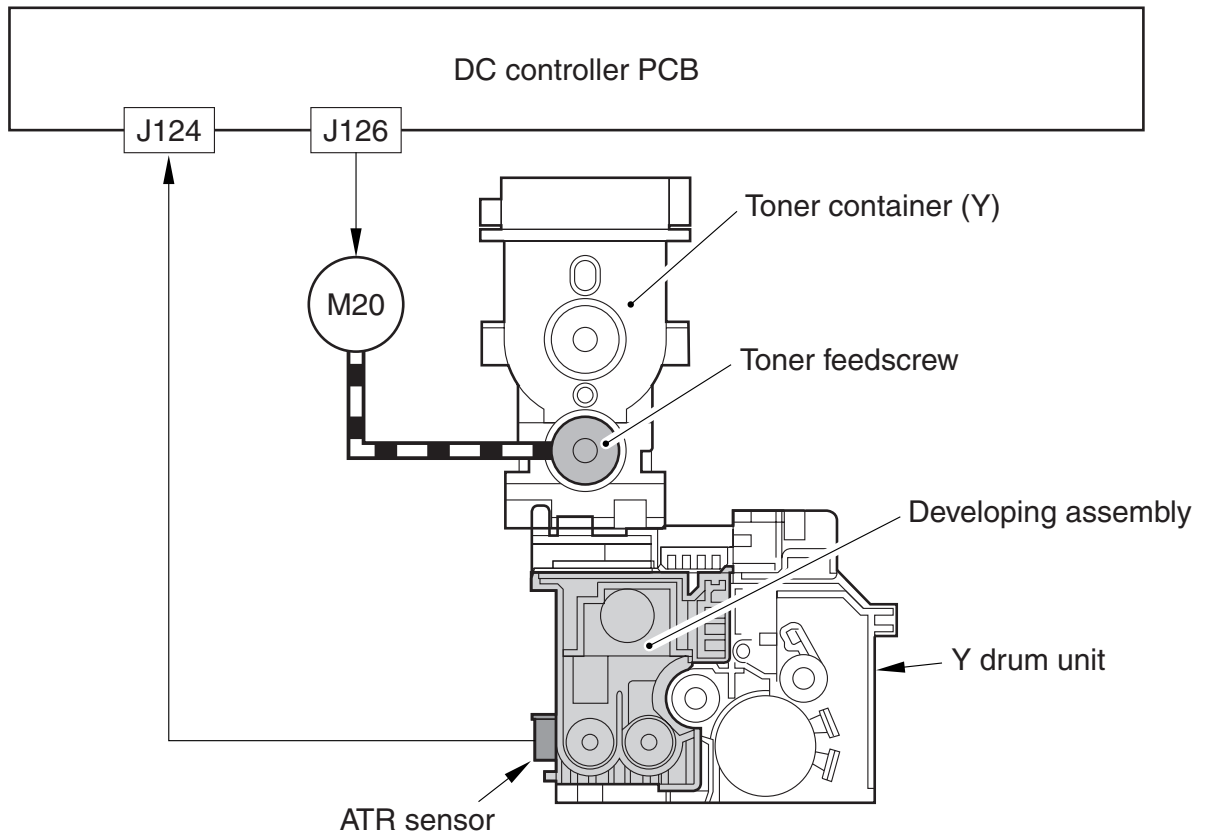

F04-404-01

5 Transfer Unit

5.1 Outline of the Transfer Unit

The transfer unit consists of 2 units: intermediate transfer unit and secondary transfer unit:

Intermediate Transfer Unit

- intermediate transfer belt (ITB)
- primary transfer roller (1 pc. each for Y, M, C, and Bk)
- ITB cleaning blade
- secondary transfer internal roller

Secondary Transfer Unit

- secondary transfer external roller
- static eliminator
- feed guide

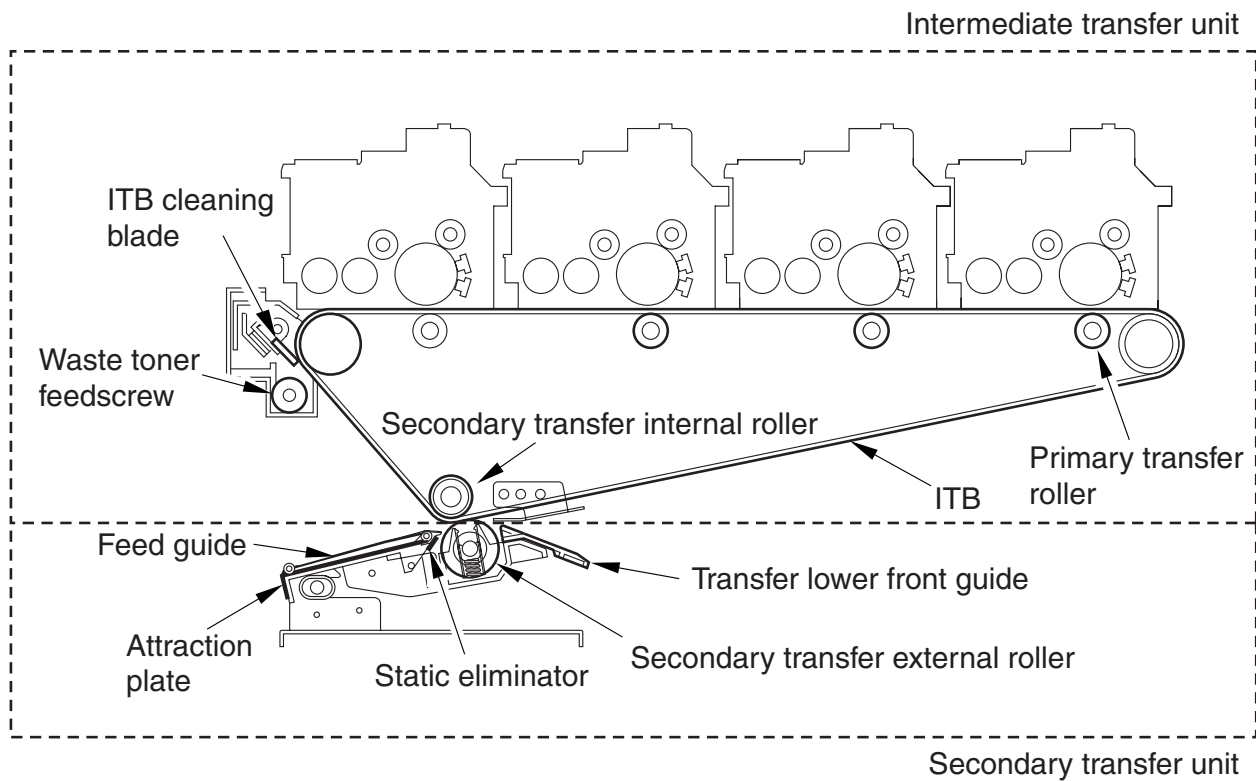

F04-501-01

5.2 Controlling the Drive of the Transfer Unit

Part	Source of drive	Remarks
Drive roller	Drum ITB motor (M1)	
Intermediate transfer belt (ITB)	Linked to drive roller	
Primary transfer roller	Linked to ITB	
Secondary transfer internal roller	Linked to ITB	
Secondary transfer external roller	Secondary transfer internal roller driven through gears	
Tension roller	Linked to ITB	
Waste toner feedscrew	Tension roller driven through gears	

T04-502-01

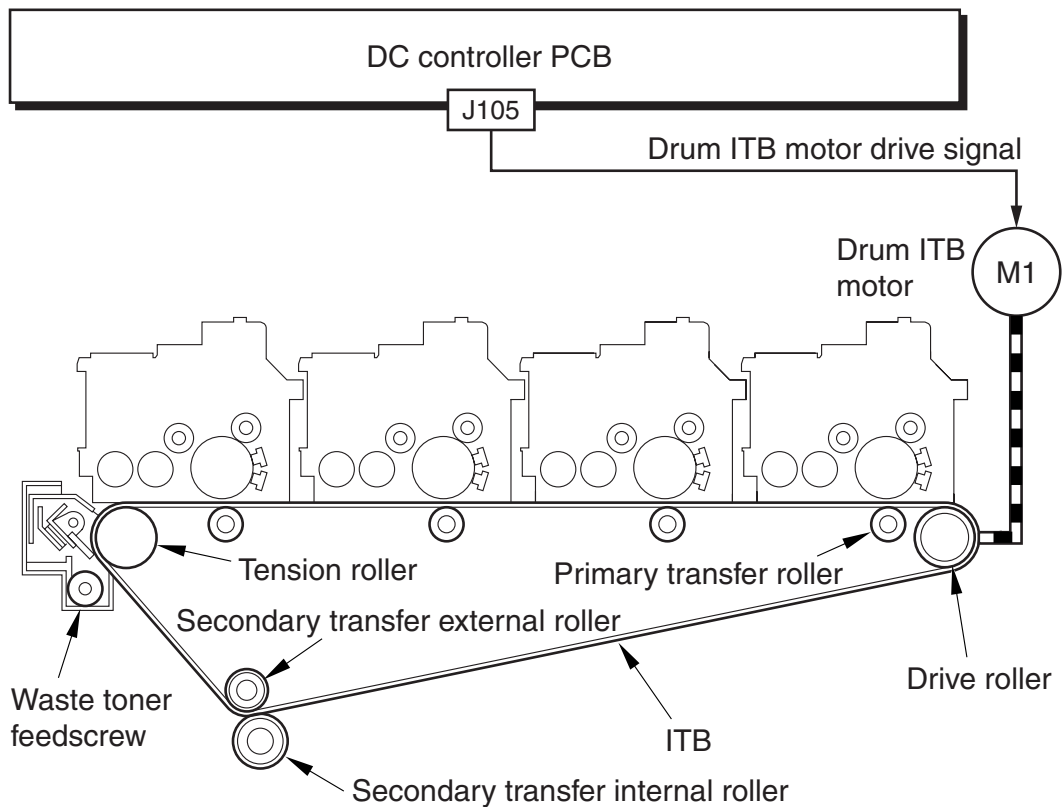

F04-502-01

5.3 Controlling the Transfer Bias

1. Primary Transfer Bias
output in keeping with the reading of the environment sensor, color mode, ATVC control
2. Secondary Transfer Bias
output in keeping with the type of paper, reading of the environment sensor, color mode (full-color/monochrome), ATVC control

e. Route of the Primary Transfer Bias/Bias Control Signal

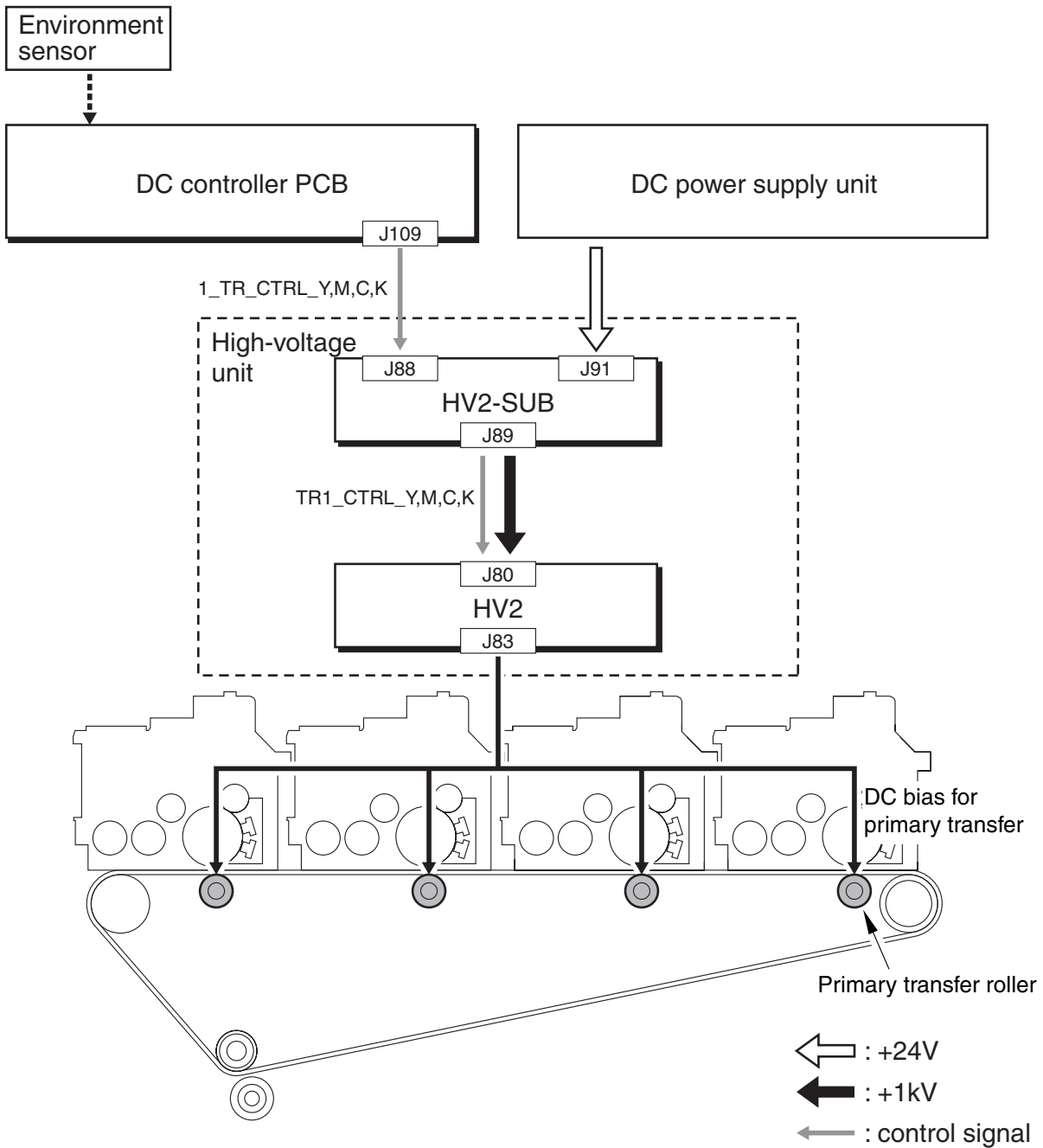

F04-503-01

f. Route of the Secondary Transfer Bias/Bias Control Signal

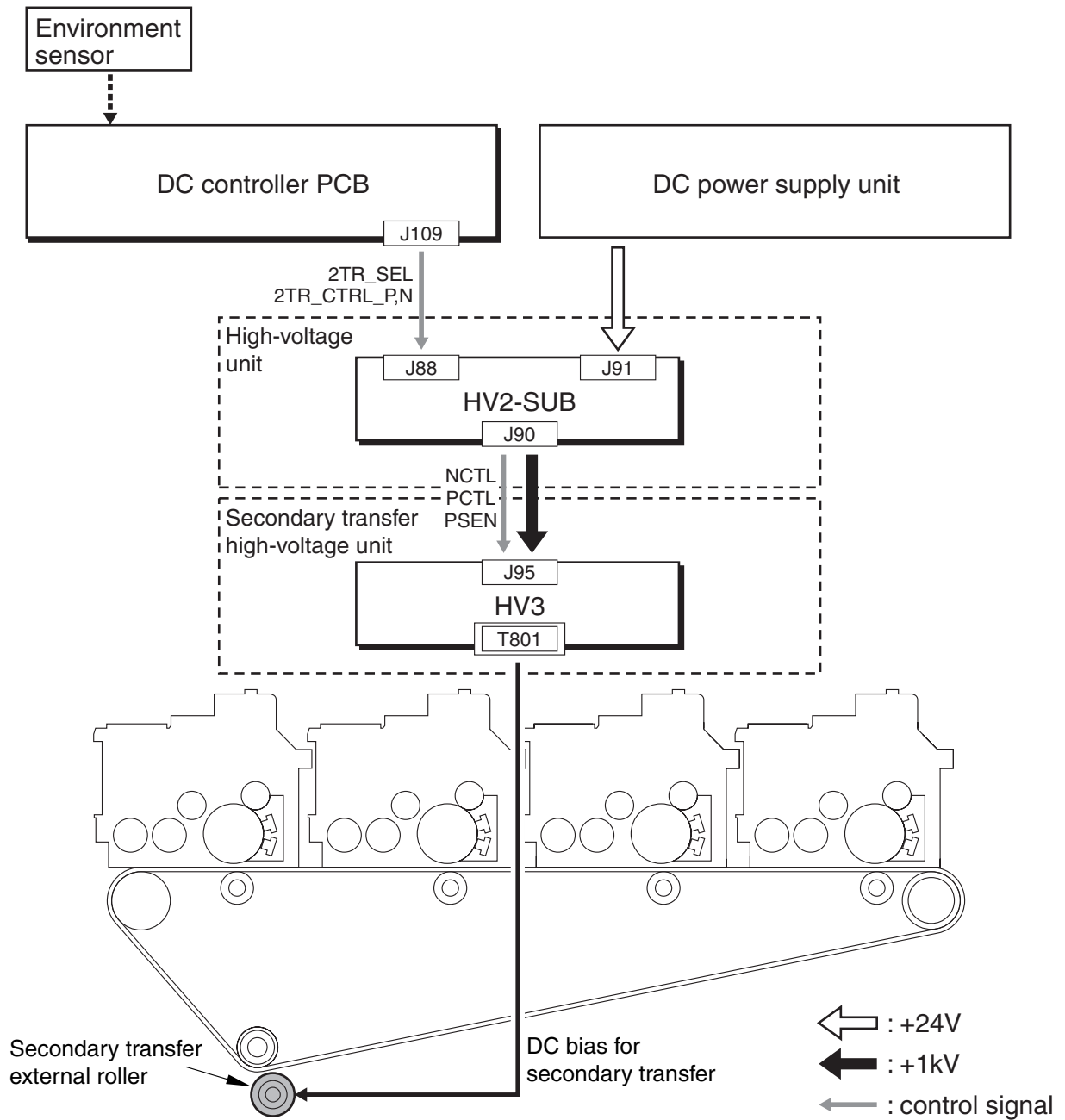

F04-503-02

5.4 Cleaning

5.4.1 Intermediate Transfer Belt (ITB)

The machine uses a cleaning blade to clean the intermediate transfer belt (ITB).

Cleaning belt: remains in contact with the ITB at all times, and used to scrape off toner from the ITB.

Scoop-up sheet: used to prevent fall of toner.

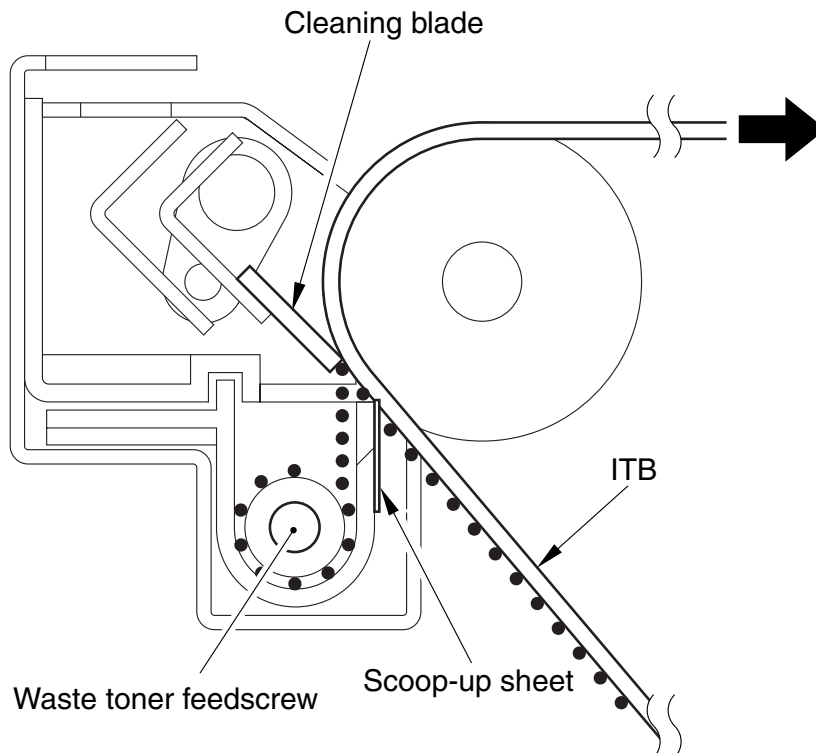

F04-504-01

5.4.2 Secondary External Roller

The secondary transfer external roller is cleaned electrostatically.

Description of Control

A bias is applied to the secondary transfer external roller alternately using the polarity used for image formation and the polarity opposite it for longer than the time it takes the roller to make a single rotation, thereby returning the toner remaining on the roller to the ITB.

Timing of Control

1. when a copy/print job ends.
2. after recovery from a jam.
3. when a sample image (or test pattern) is formed as part of image stabilization control.

5.4.3 Collecting Waste Toner

The machine uses the following mechanism to collect waste toner.

Waste Toner

The waste toner is scraped off by the cleaning blade, and is moved to the waste toner box by the waste toner feedscrew.

Waste Toner Box Full Detection

The waste toner sensor consists of a LED (light-emitting) and a phototransistor (light-receiving) to find out when the waste toner box becomes full.

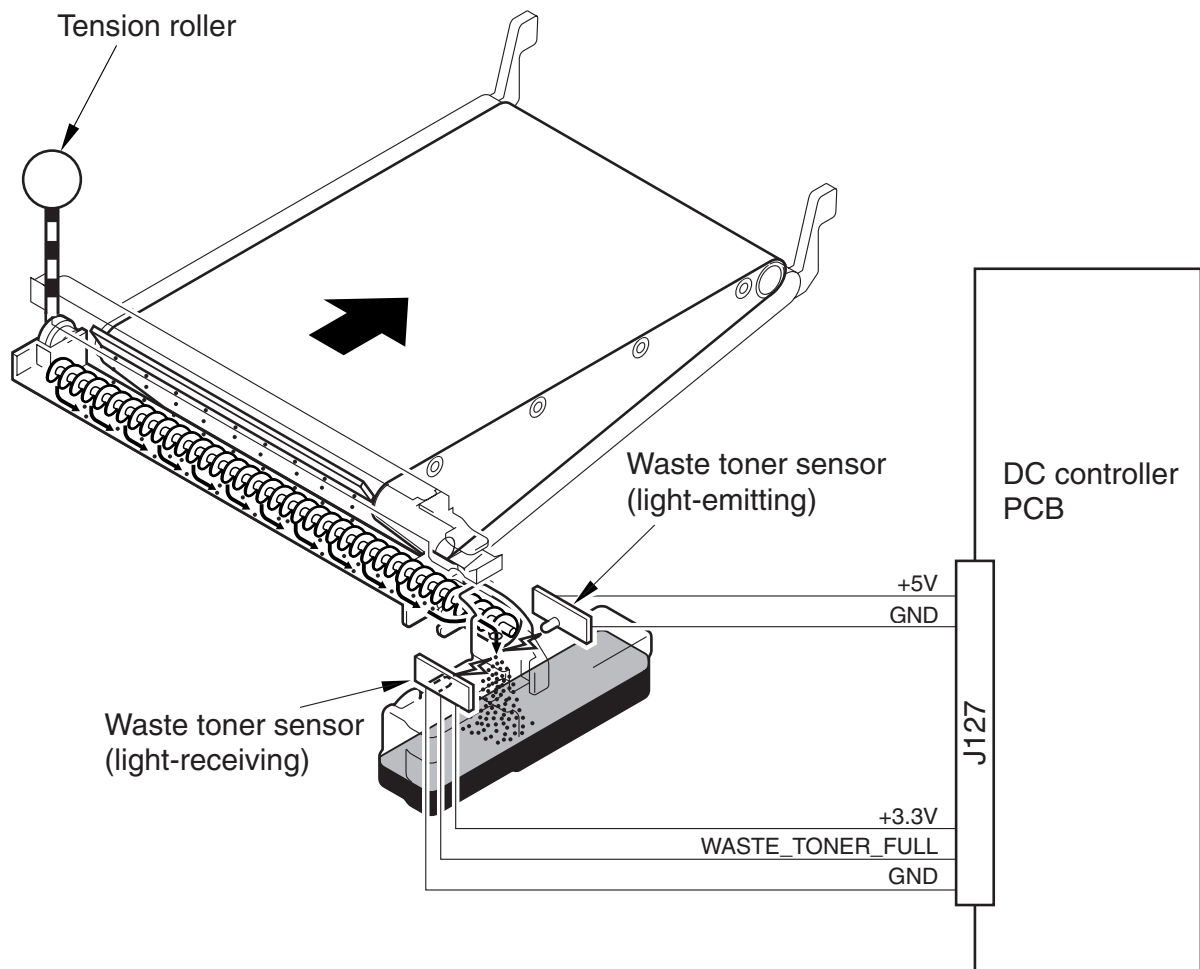

F04-504-02

5.5 Separation

The machine uses the following mechanism to separate paper:

1. Separation
 - Curvature (mechanical)
 - Static Eliminator (static electricity)
It is grounded to lower the potential occurring on the back of paper, thus facilitating the separation of paper from the ITB.
2. Separate Auxiliary Mechanism
 - Feed Guide
It is used to prevent increases in the potential occurring on the back of paper because of friction used when it is moved to the fixing assembly. It is used to prevent image faults caused by contact with the attraction plate.
 - Attraction Plate
It is grounded, and is used to draw paper.

The eccentric arrangement of the 2 rollers causes the paper to separate by taking advantage of the rigidity of paper (curvature separation).

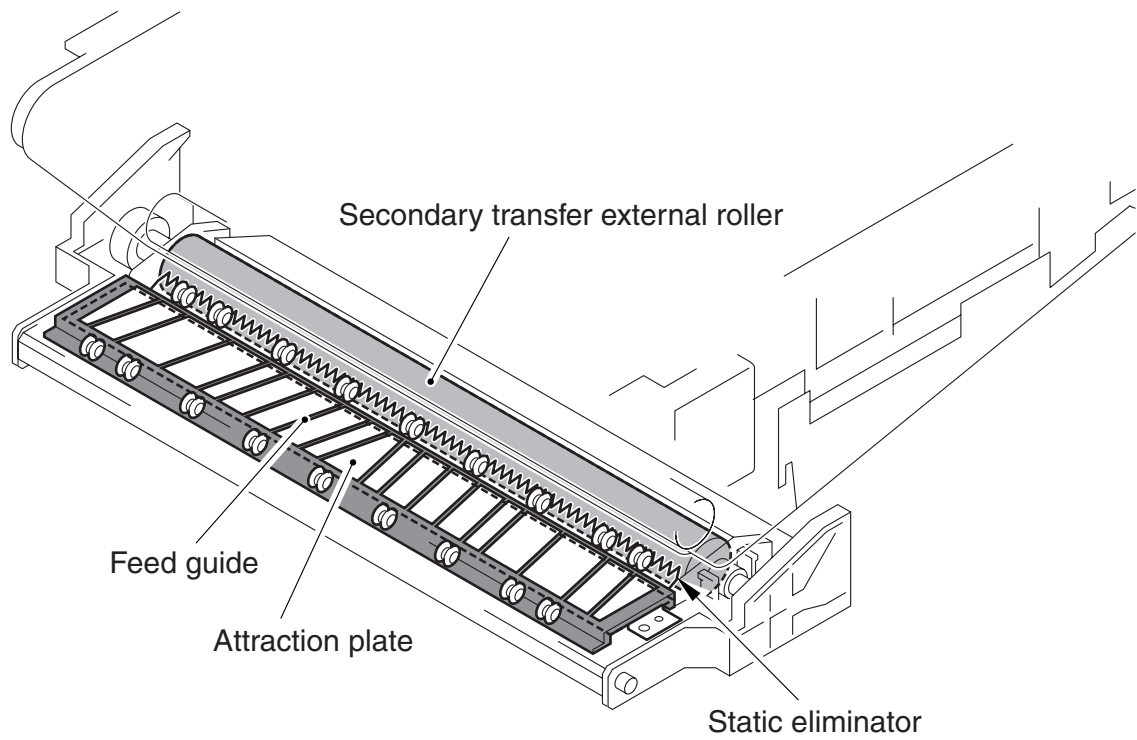
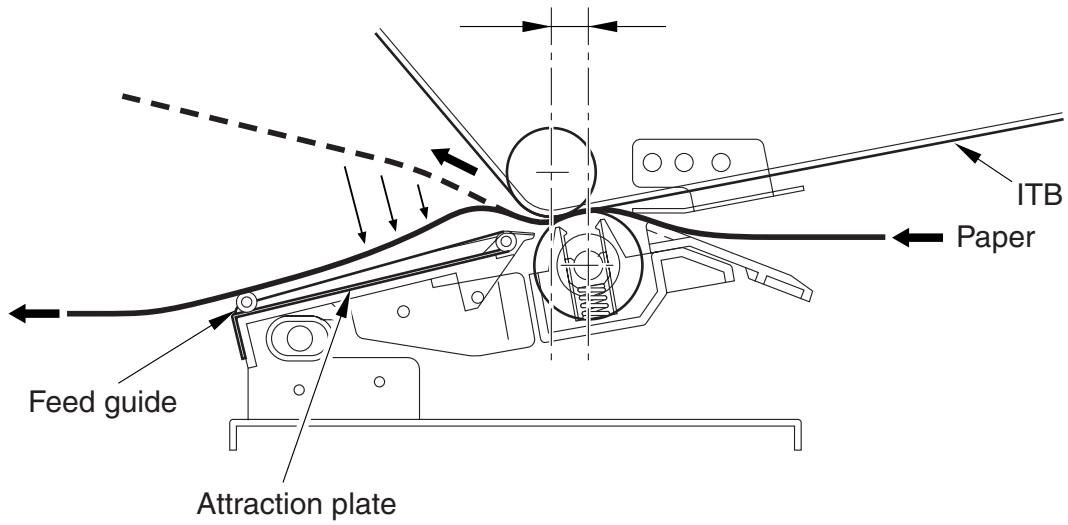

F04-505-01

6 Disassembly and Assembly

6.1 Removing the Intermediate Transfer Unit

- 1) Open the front cover, and turn the intermediate transfer unit releasing lever to unlock it.
- 2) Slide out the manual feed unit.
- 3) Remove the screw [1], and detach the middle right cover [2].

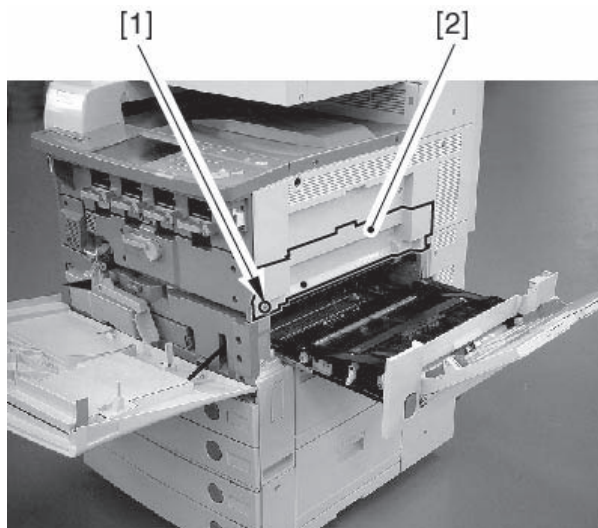

F04-601-01

- 4) Release the escape lever [1].

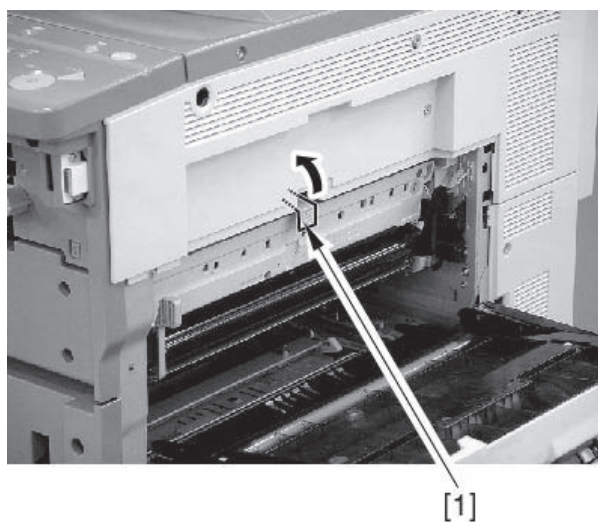

F04-601-02

- 5) While picking the tabs at the front and the rear, slide out the intermediate transfer unit [1]; then, detach it by holding it by the indicated area [2].

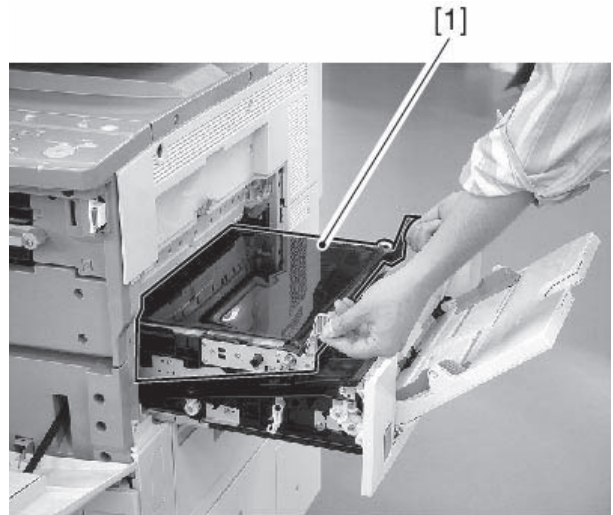

F04-601-03

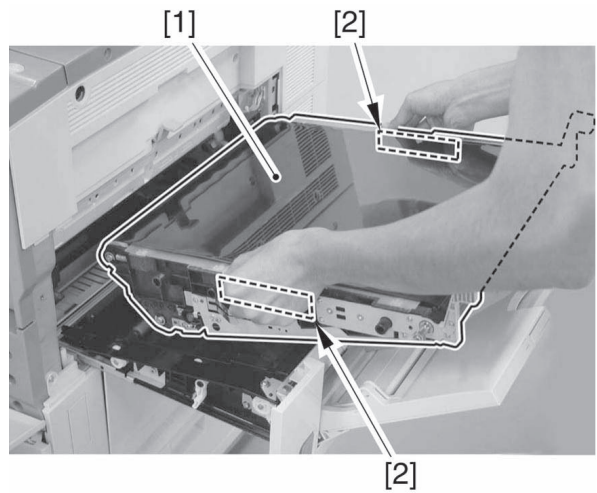

F04-601-04

6.2 Removing the Intermediate Transfer Belt

- 1) Remove the intermediate transfer unit.
(See 6.1 'Removing the Intermediate Transfer Unit.')
- 2) Remove the 4 screws [1], and detach the belt cover [2].

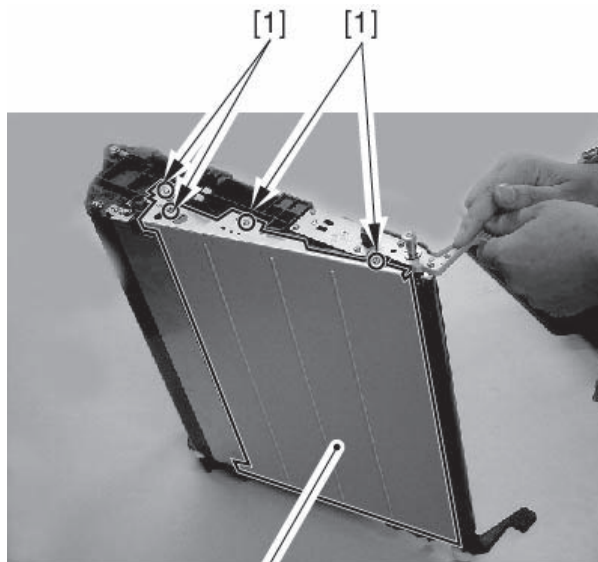

[2]

F04-602-01

- 3) Remove the screw [1], and detach the varistor [2].

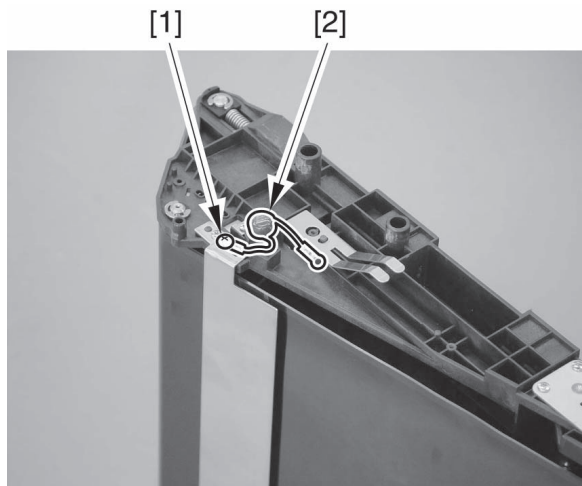

F04-602-02

- 4) Remove the screw [1], and detach the transfer guide plate [2].

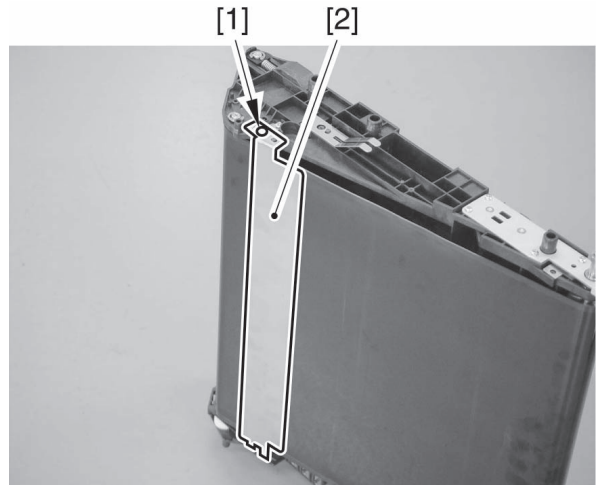

F04-602-03

- 5) Remove the 4 screws [1] at the rear, and pull out the link plate (rear) [2].

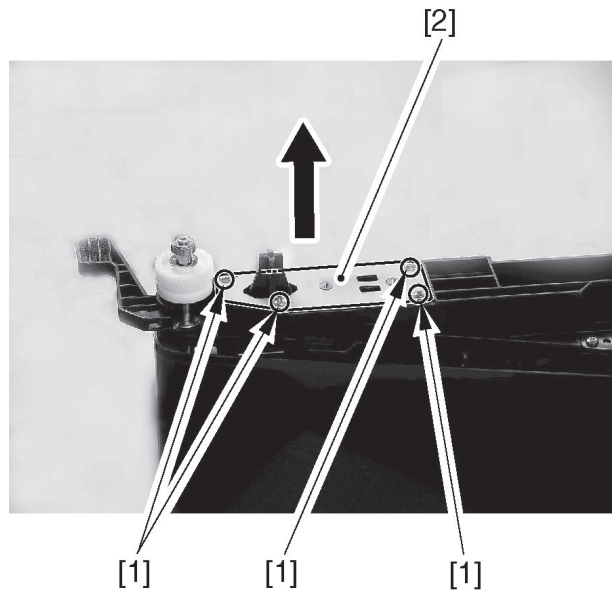

F04-602-04

- 6) Fit the boss [1] on the frame at the rear into the recess [A] in the middle right cover so that the unit is upright.

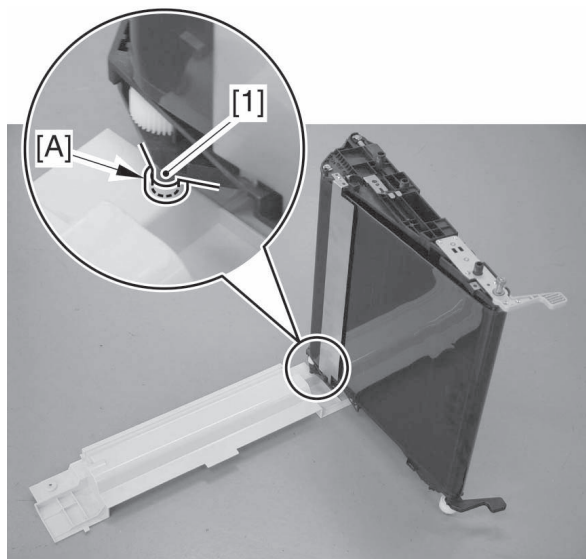

F04-602-05

- 7) Be sure that the rear link plate [1] is on the opposite of the middle right cover so that the intermediate transfer unit will not fall down.

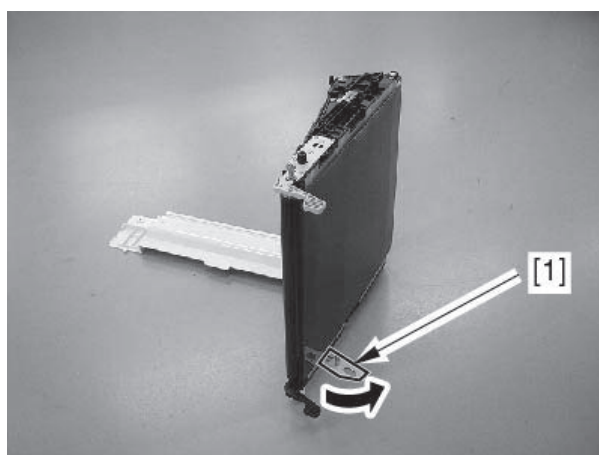

F04-602-06

- 8) Remove the 4 screws at the rear [1], and pull out the link plate (front) [2]; then, rotate it 180°.

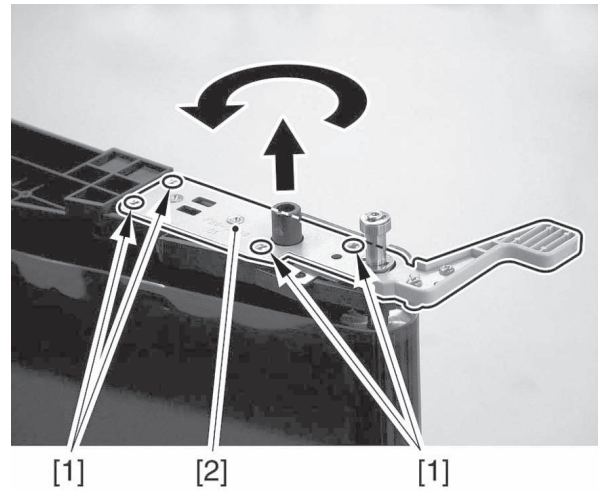

F04-602-07

- 9)



When you have pulled out the belt, keep it upright or place it on paper to avoid damage.

After bending the transfer frame, pull out the transfer belt [1] upward.

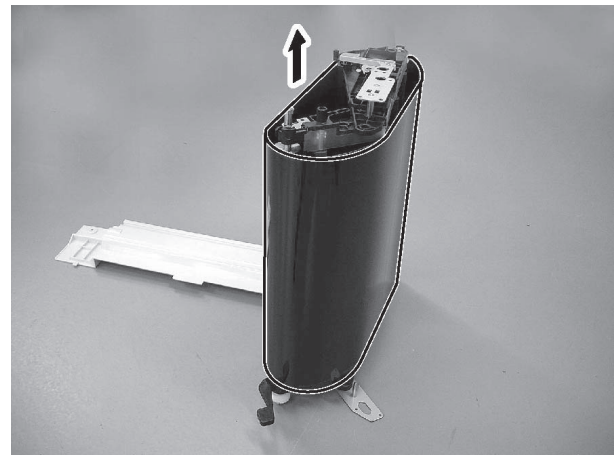

F04-602-08

6.3 Points to Note When Attaching the Intermediate Transfer Belt



Check to make sure that the secondary transfer internal roller is free of soiling. If dirt is found, clean it with alcohol.

- 1) Attach the intermediate transfer belt so that the marking on its surface is to the rear.

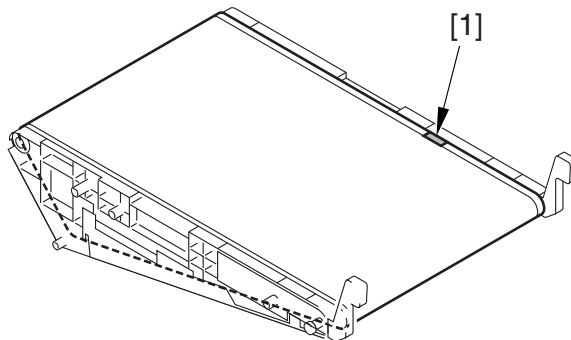

F04-603-01

- 2) When fitting the belt, place the unit in a low position so that the belt may be fitted from above and straight down.



F04-603-02

- 3) Check to make sure that the edge [A] of the belt does not ride over the rib [B] of the tension roller.

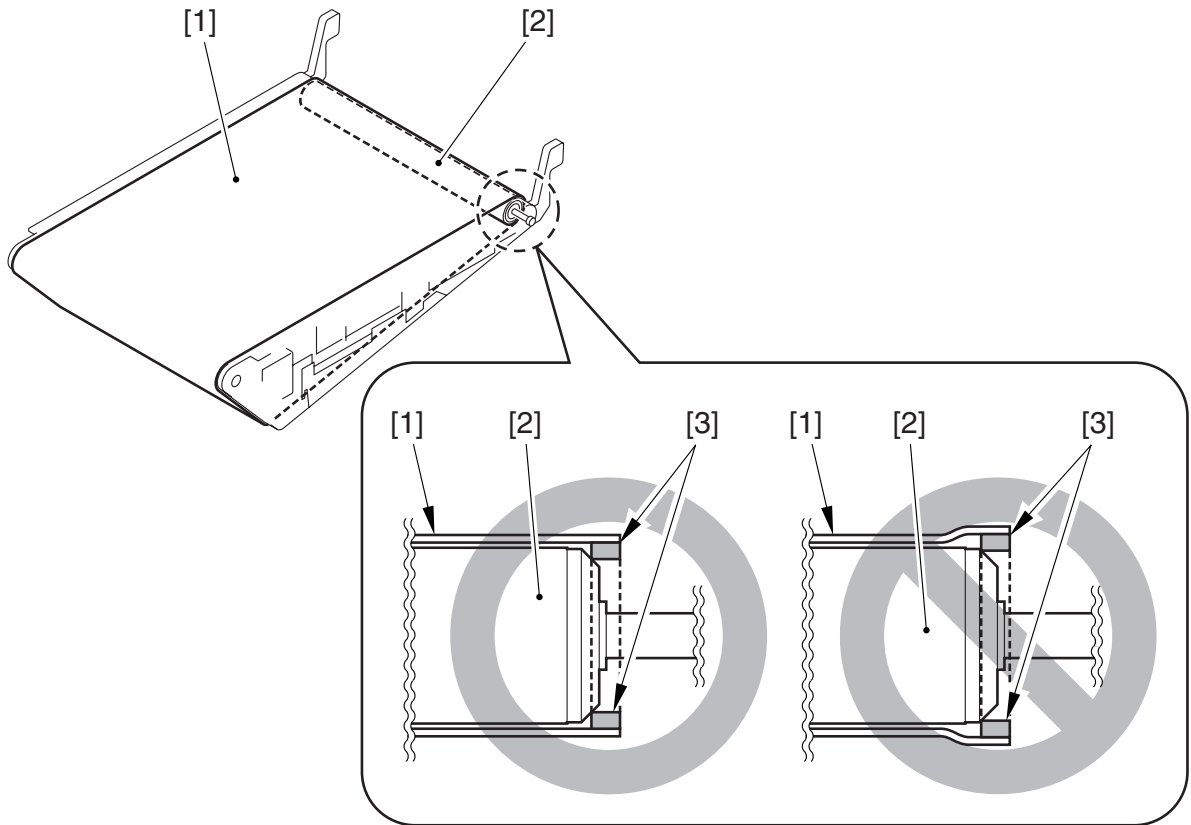

F04-603-03

6.4 Removing the Primary Transfer Roller

- 1) Remove the intermediate transfer belt.
(See 6.2 'Removing the Intermediate Transfer Belt.')
- 2) Bend over the edge of the sheet [1] at the rear; while picking the edge [3] of the primary transfer roller [2], detach it upward.

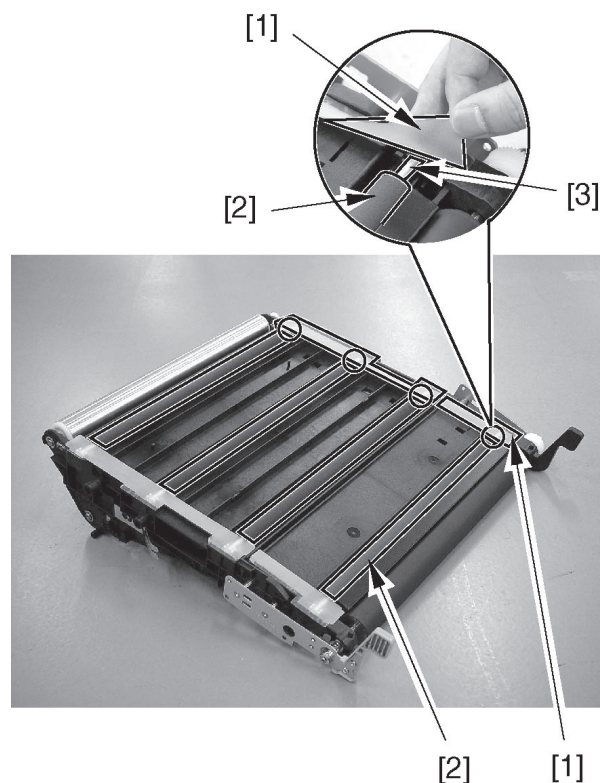

F04-604-01



Points to Note When Mounting the Primary Transfer Roller

1. Bend over the edge of the sheet [1] at the front, and fit the edge [2] of the roller and then fit its rear side.

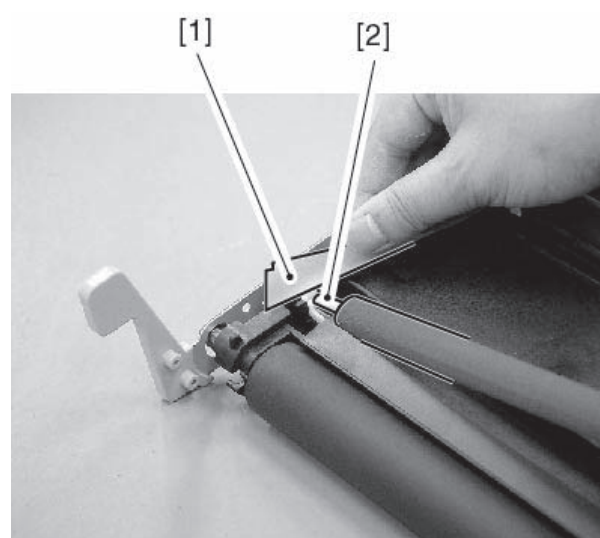

F04-604-02



Points to Note When Mounting
the Primary Transfer Roller

2. Check to make sure that the edge of the sheet [1] is on the inner side of the rib [2].

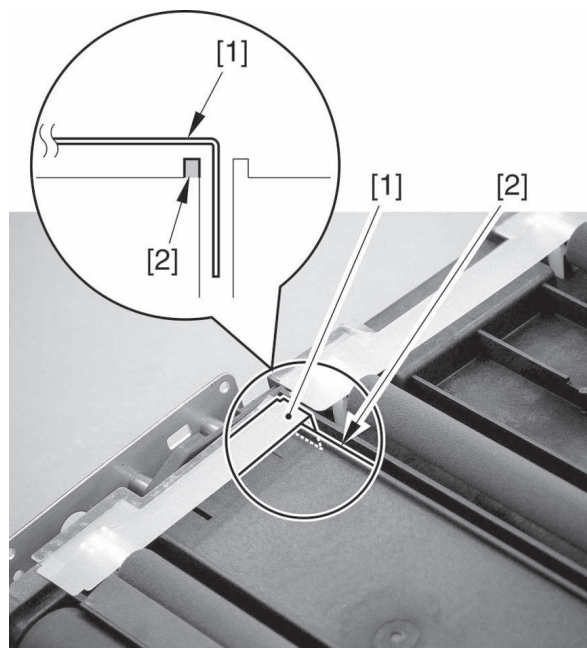

F04-604-03

6.5 2 Removing the Secondary Transfer Internal Roller

- 1) Remove the intermediate transfer belt.
(See 6.2 'Removing the Intermediate Transfer Belt.')
- 2) Extend the belt frame, and fit the link plate at both front and rear.
- 3) Remove the 2 screws [1], and remove the positioning block [2] at the rear.

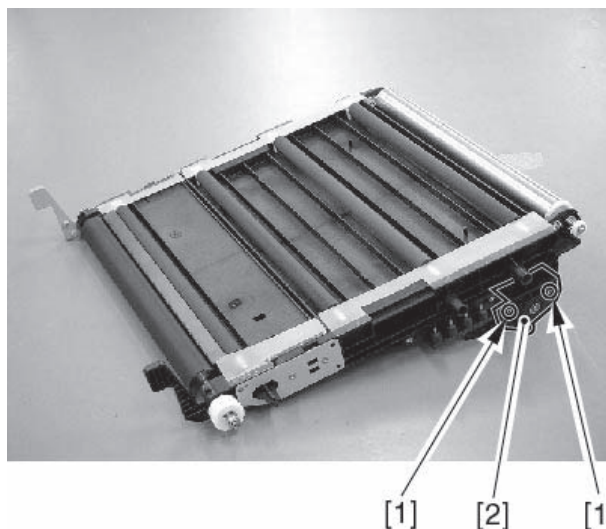

F04-605-01

- 4) Remove the E-ring [1], gear [2], and bushing [3].

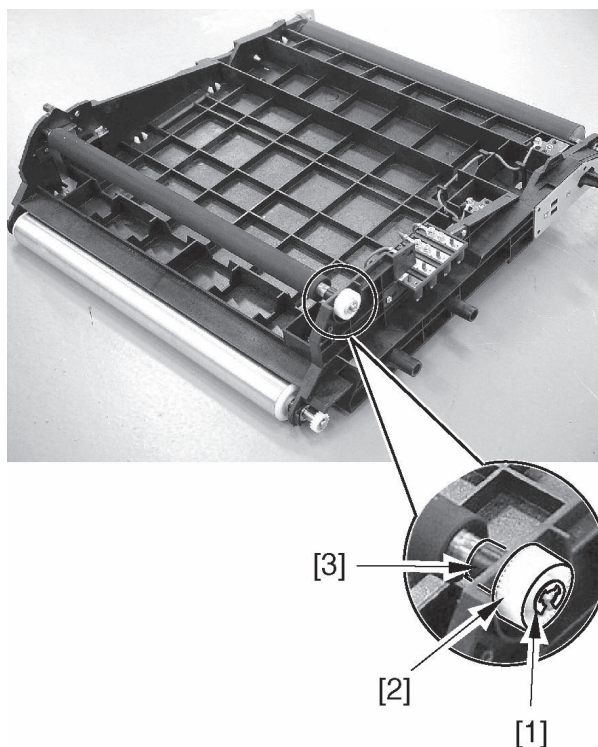

F04-605-02

- 5) Remove the E-ring [1] and the bushing [2] at the front; then, remove the secondary transfer internal roller [3].

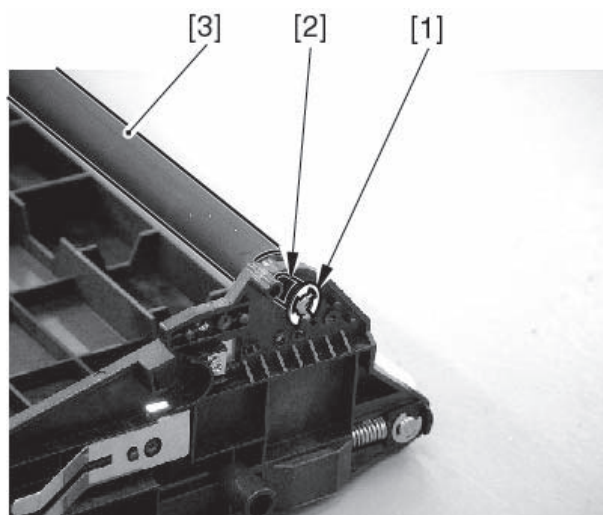

F04-605-03



Points to Note When Mounting the Secondary Transfer Internal Roller

When mounting the bushing at the front, be sure to fit the bushing [2] while avoiding the left spring [1] found on the inner side of the frame.

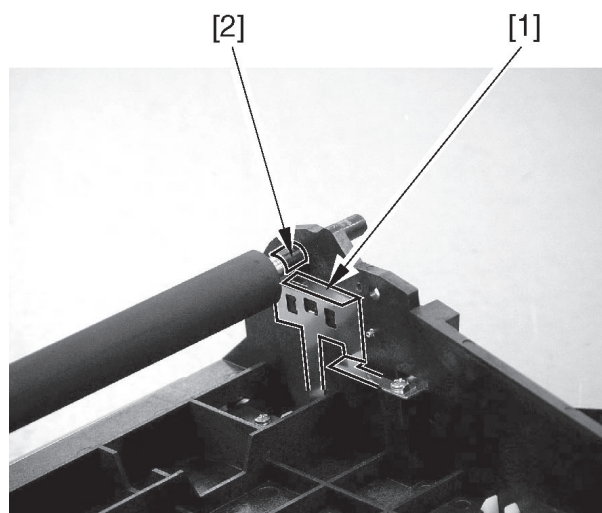

F04-605-04

6.6 Removing the Drive Roller

- 1) Remove the intermediate transfer belt.
(See 6.2 'Removing the Intermediate Transfer Belt.')

2)



1. The spring found at the front is under pressure; thus, starting at the front can cause the spring to snap out. Be sure to start at the rear.
2. When removing the gear, be sure to take care not to lose the parallel pin.

At the rear, remove the following: E-ring [1], washer [2], bearing [3], E-ring [4], gear [5], parallel pin [6], gear butting spacer [7], bearing [8], and 2 E-rings [9].

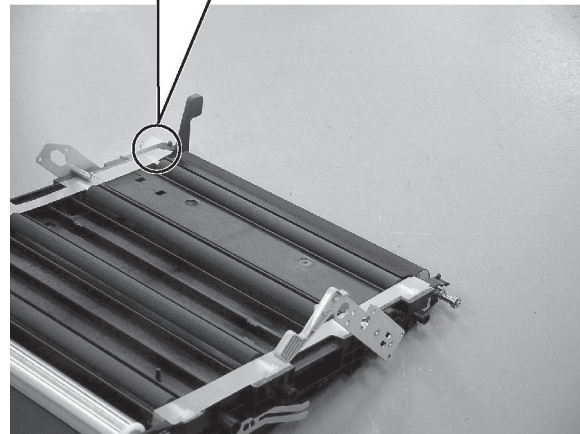
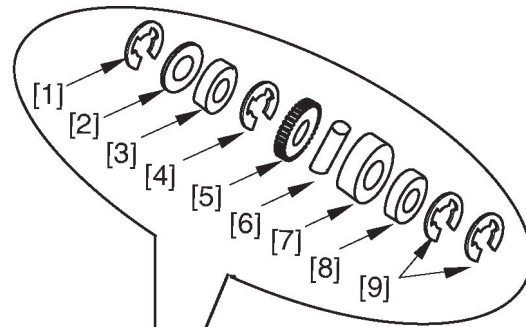

F04-606-01

- 3) At the front, remove the following: E-ring [1], washer [2], bearing [3], E-ring [4], washer [5], spring [6], washer [7], bearing [8], grounding plate [9].

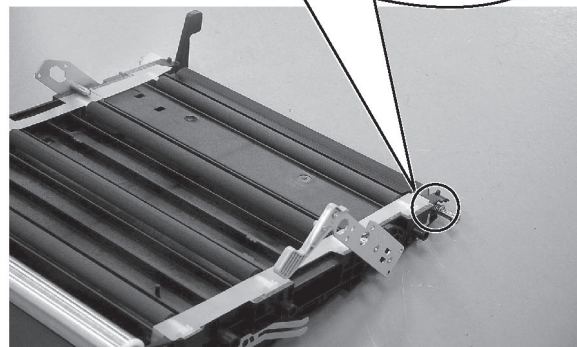
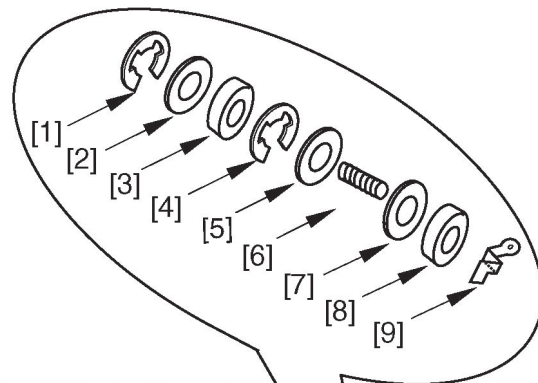

F04-606-02

- 4) Remove the bearing [1] found at the rear, and free the drive roller [2] from the cut-off [A] of the frame found at the front.

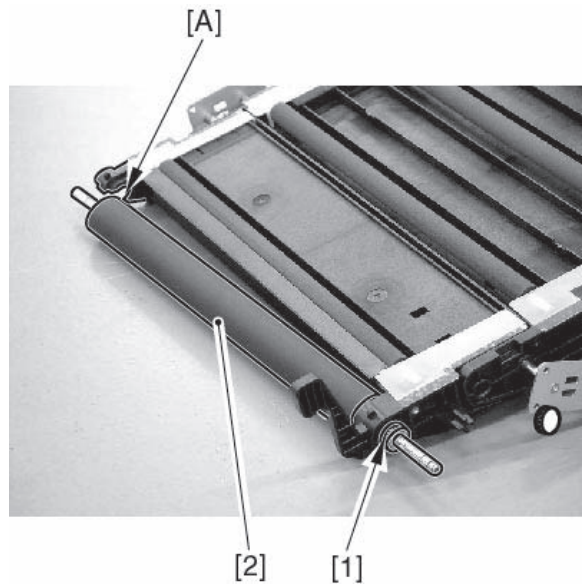

F04-606-03



Points to Note

When attaching the washer, spring, and washer at the front, be sure to fit the E-ring after forcing down the spring together with the washer until the E-ring groove [A] of the drive roller shaft is in view.

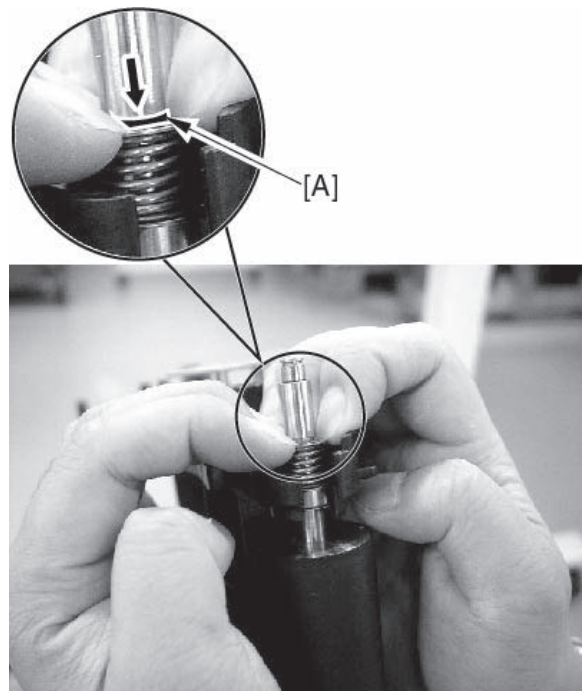

F04-606-04

6.7 Removing the Secondary Transfer External Roller

- 1) Remove the transfer/feeder unit. (See 8.14 'Removing the Fixing/Feeder Unit' in Chapter 5.)

2)



Take care not to touch the surface of the secondary transfer external roller.

Holding the tabs [1] at both ends, remove the secondary transfer roller [2].

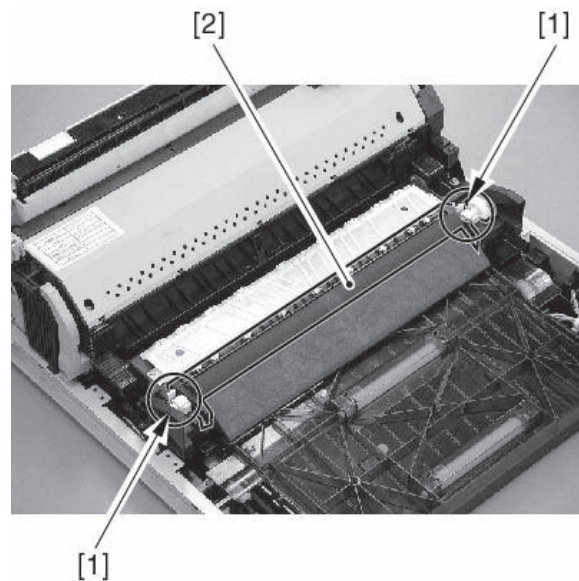

F04-607-01



If the white spacer [2] of the secondary transfer roller [1] becomes soiled with toner or the like, the roller can fail to rotate, causing lines. Be sure to see to it that the spacer moves.

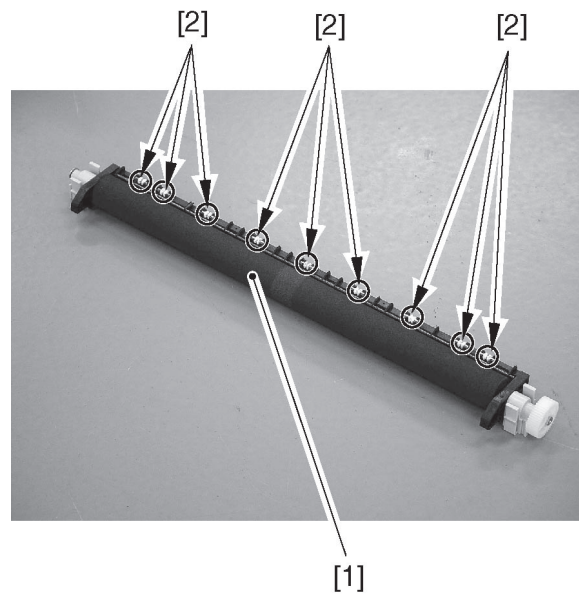

F04-607-02



When mounting the roller [1], be sure that the edge of the leaf spring [2] found at the rear and used for electrical continuity is not bent over.

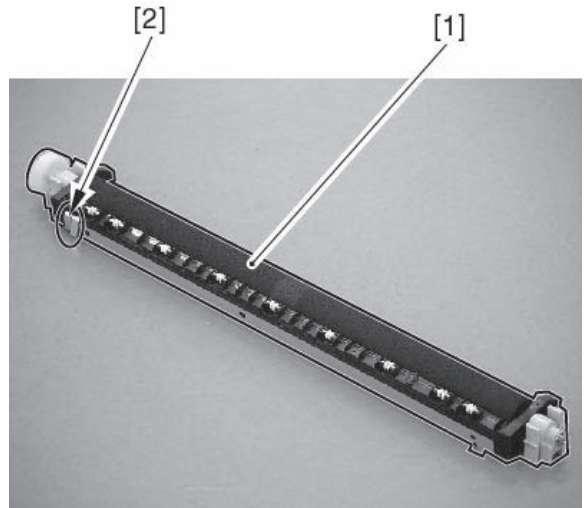

F04-607-03



Be sure that the spring [1] is securely fitted to the back of the tab used to remove/attach the roller.

Pay attention to the orientation of the spring, as different types are used between front and rear.

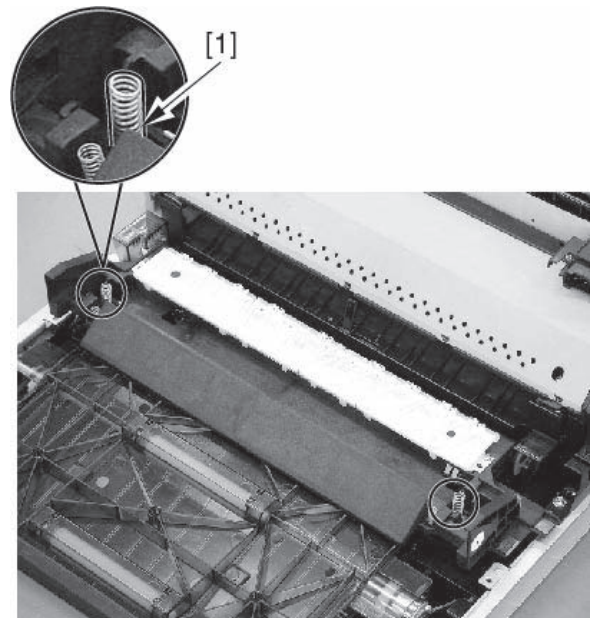

F04-607-04

6.8 Removing the Secondary Transfer Unit

- 1) Slide out the fixing/feeder unit.
- 2) Remove the duplexing open/closed guide. (See 8.33 ‘Removing the Developing Registration Clutch’ in Chapter 5.)
- 3) Remove the screw [1] at the front, and detach the secondary transfer unit retainer [2].

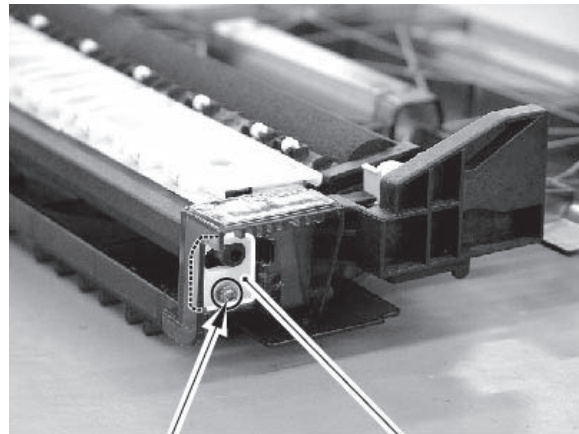

[1]

[2]

F04-608-01

4)



When removing the secondary transfer unit, be sure to take care not to lose the tension spring [1] found behind it.

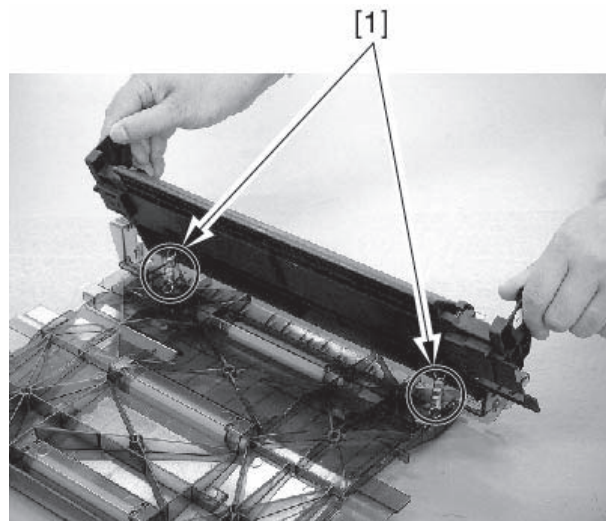

F04-608-02

Hold the grips at the front and the rear, and slide the front side to the right to pull out the secondary transfer unit [1].

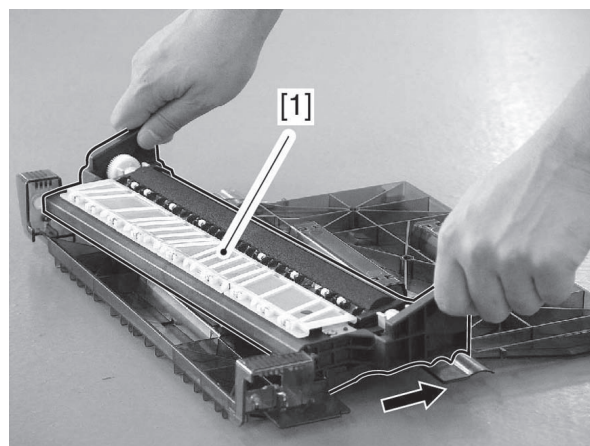

F04-608-03

6.9 Removing the Pattern Reader Unit

- 1) Remove the intermediate transfer unit.
(See 6.1 'Removing the Intermediate Transfer Unit.')
- 2) Remove the 4 screws [1], and detach the upper right cover [2].

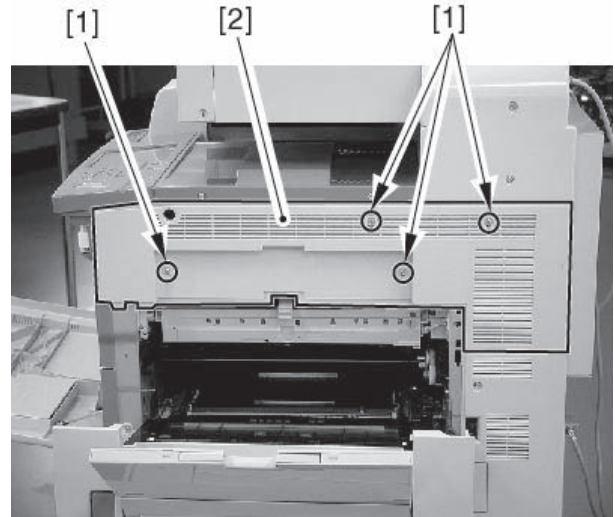

F04-609-01

- 3) Disconnect the 2 connectors [1], and remove the screw [2]; then, free the plate [4] from the hook of the upper right stay [3], and detach the pattern reader unit [5].

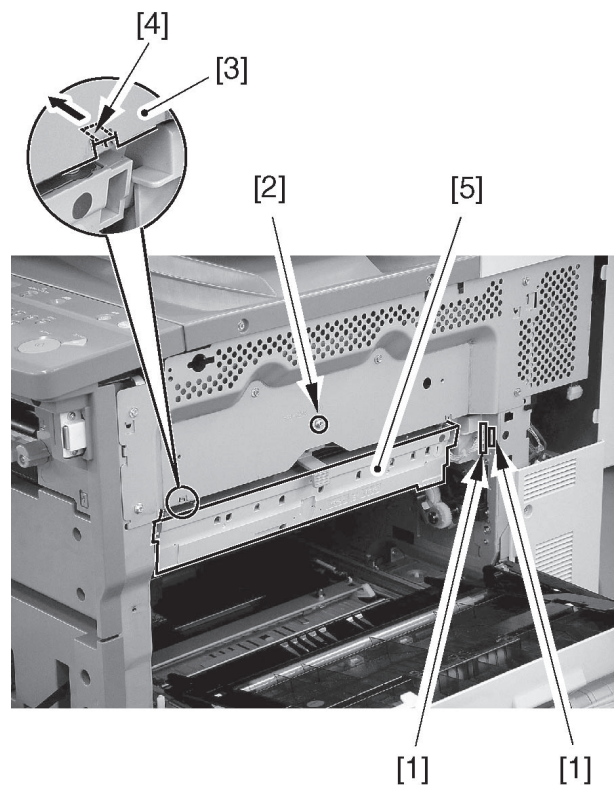

F04-609-02

Mounting to the Machine

- 1) Match the boss [1] with the rail [2].

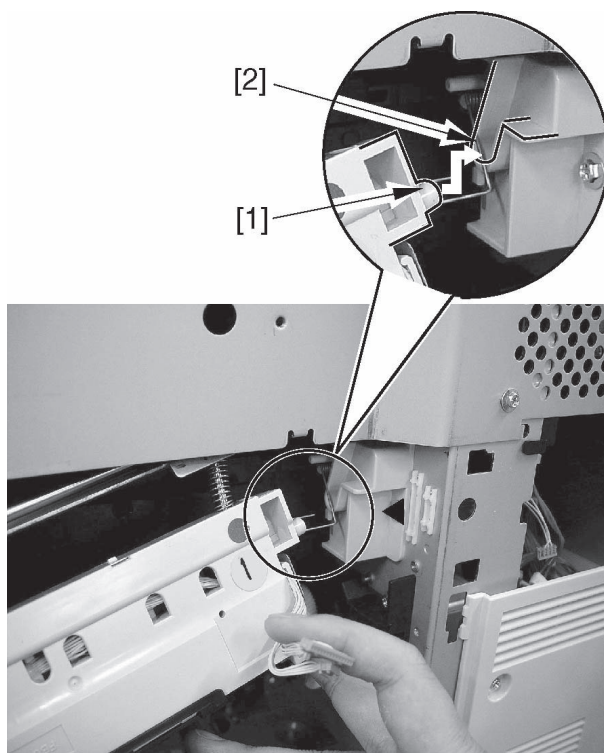

F04-609-03

- 2) While pushing the cleaning member [1] to the right, fit it in while taking care so that it will not hit the slide rail [2] of the intermediate transfer unit on the side of the machine's side plate.

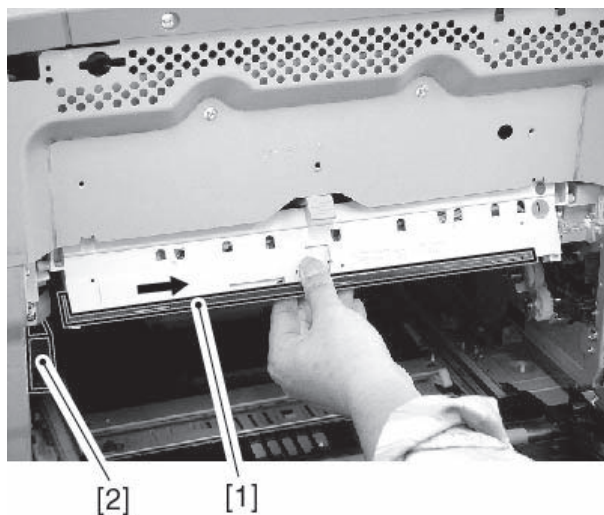

F04-609-04

- 3) Connect the connector [1]; then, while pulling the escape lever [2] toward the front, hook the plate [3] on the left/right claw [4], and secure it in place with a screw [5] over the screw hole.

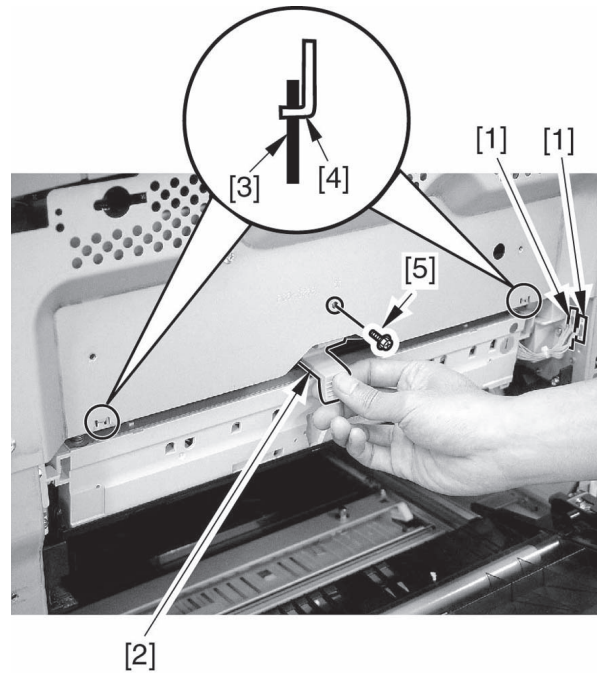

F04-609-05

6.10 Removing the SALT Sensor

- 1) Remove the pattern reading unit. (See 6.9 'Removing the Pattern Reading Unit.')
- 2) Remove the 3 screws [1], and detach the plate from the rear of the pattern reader unit [2].

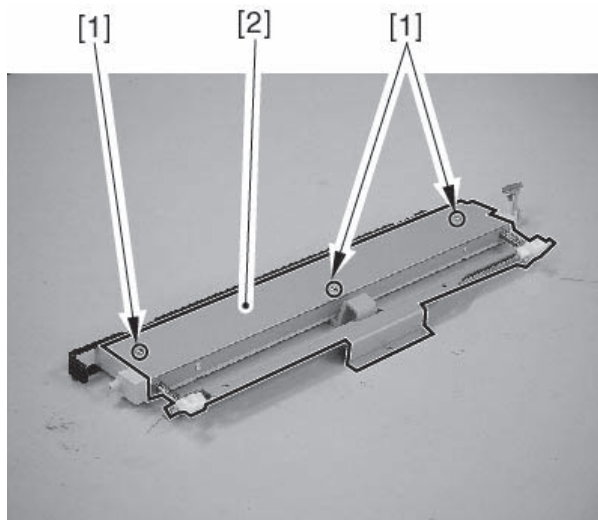

F04-610-01



Points to Note

When mounting the plate [1], be sure to position it so that it is farther on the inner side than the cleaning member [2].

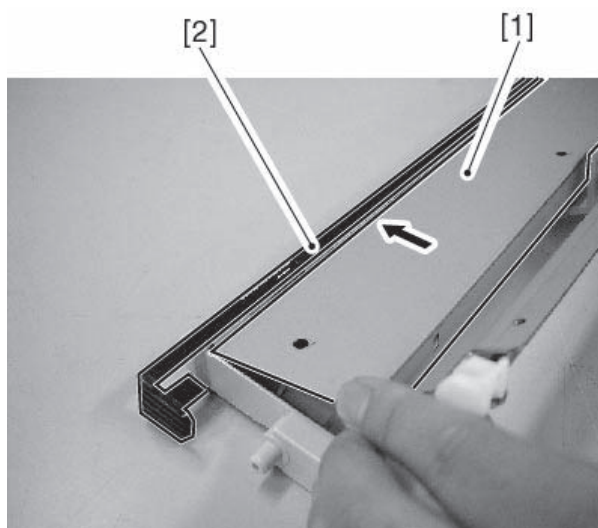

F04-610-02

- 3) Remove the 2 screws [1], and disconnect the connector [2]; then, detach the SALT sensor [3].

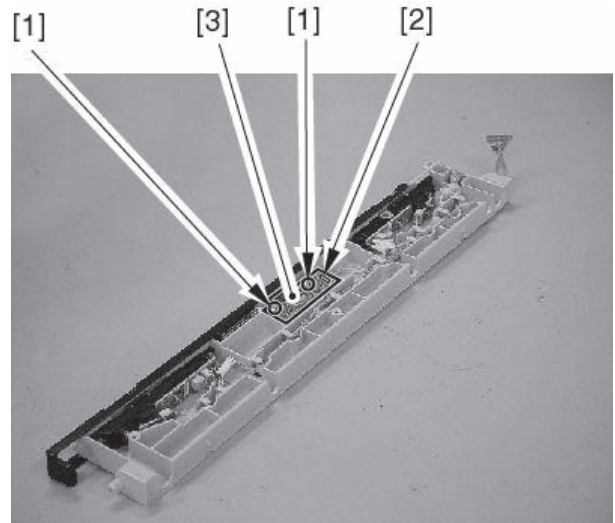

F04-610-03

6.11 Removing the Auto Registration Sensor PCB

- 1) Remove the pattern reader unit. (See 6.9 ‘Removing the Pattern Reader Unit.’)
- 2) Remove the 3 screws [1], and detach the plate found to the rear of the pattern reader unit [2].

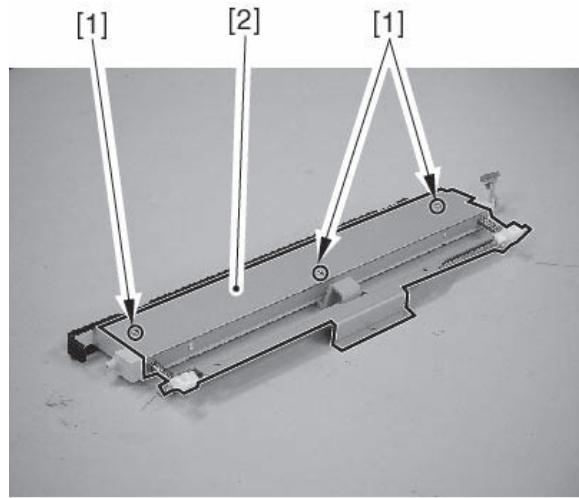

F04-611-01



Points to Note

When mounting the plate [1], be sure that its edge is farther on the inner side than the cleaning member [2].

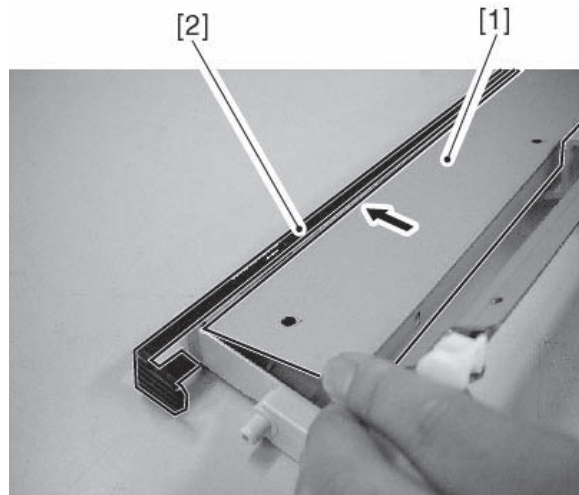

F04-611-02

- 3) Remove the 2 screws [1], and disconnect the 2 connectors [2]; then, remove the auto registration sensor PCB (front) [3].



The auto registration sensor PCB (rear) is also removed in the same way.

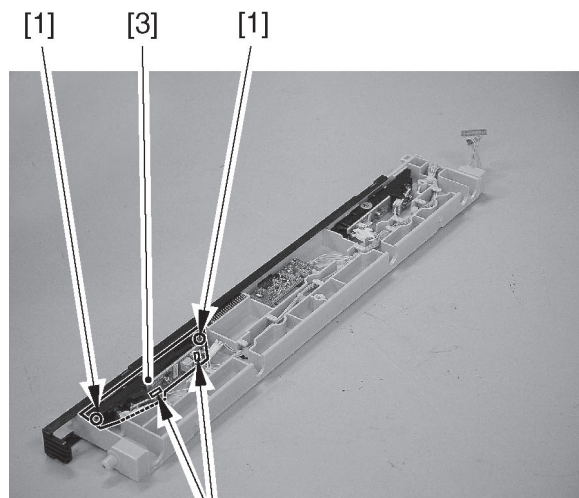

F04-611-03

6.12 Removing the Waste Toner Feedscrew



Remove the waste toner feedscrew only when a jam has occurred and the sheet [1] attached to the feedscrew has become damaged or bent (rendered useless).

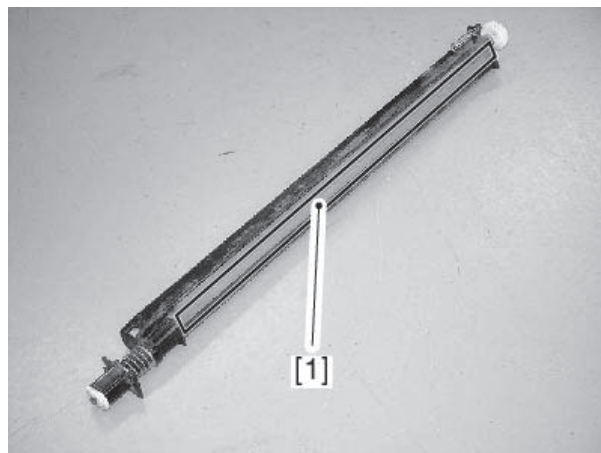

F04-612-01

- 1) Remove the transfer cleaning unit. (See 6.21 'Removing the Transfer Cleaning Unit.')
- 2) Turn the intermediate transfer unit releasing lever [1] slightly counterclockwise, and remove the screw [2]; then, remove the waste toner feedscrew [3].

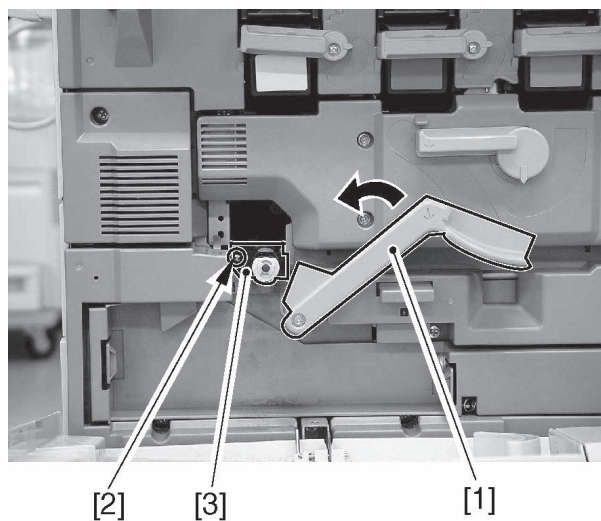

F04-612-02

6.13 Removing the Waste Toner Detection PCB

- 1) Open the front cover, and turn the intermediate transfer unit releasing lever [1] to detach the waste toner container [2].

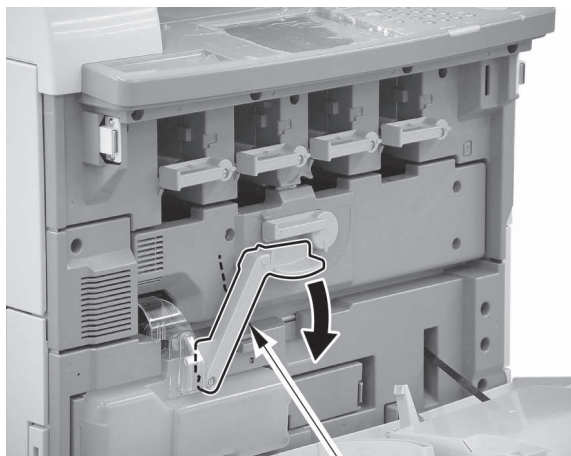

[1]

F04-613-01

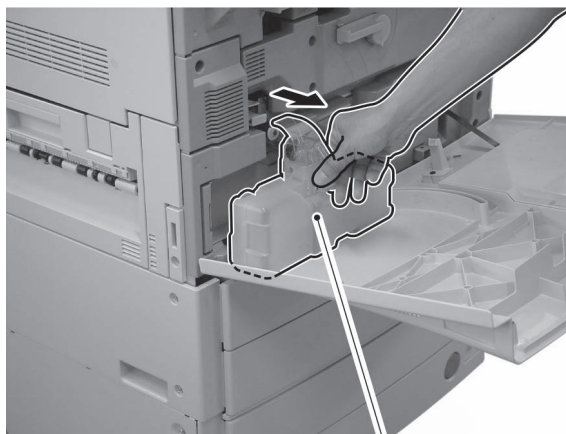

[1]

F04-613-02

- 2) Remove the screw [1] and the 2 hinge pins [2]; then, detach the front cover.

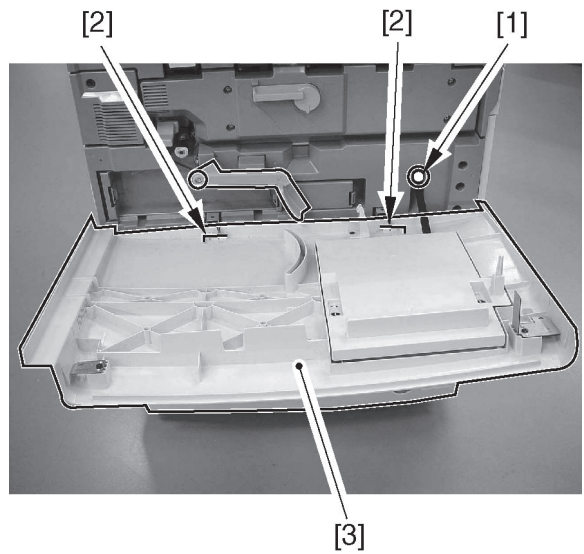

F04-613-03

- 3) Remove the screw [1], and detach the intermediate transfer unit releasing lever [2].

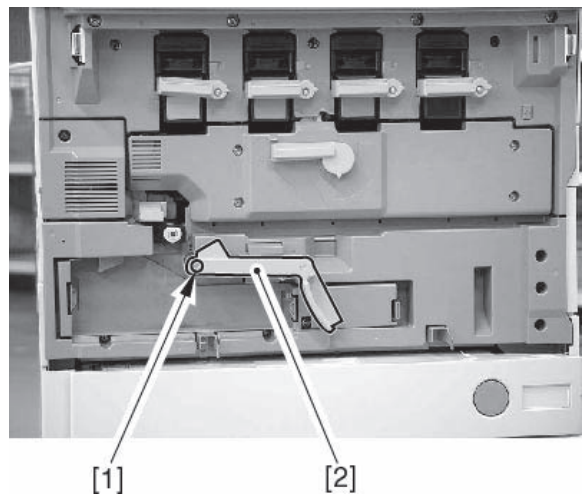

F04-613-04

- 4) Remove the screw, and detach the cleaner fan cover [2].

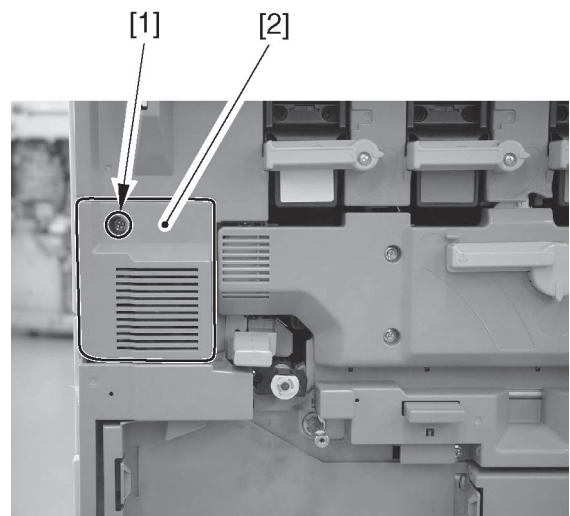

F04-613-05

- 5) Disconnect the connector [1], and remove the 5 screws [2]; then, detach the inside cover (lower) [3].

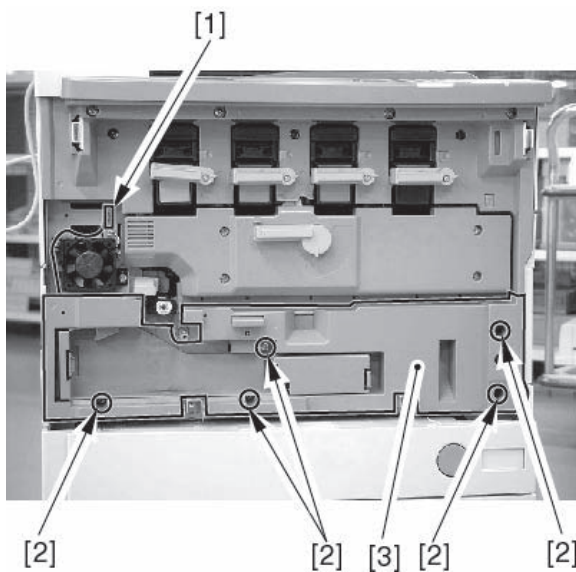

F04-613-06

- 6) Remove the 2 screws [1] found behind the fixing/feeder unit; then, detach the waste toner detection PCB cover [2].

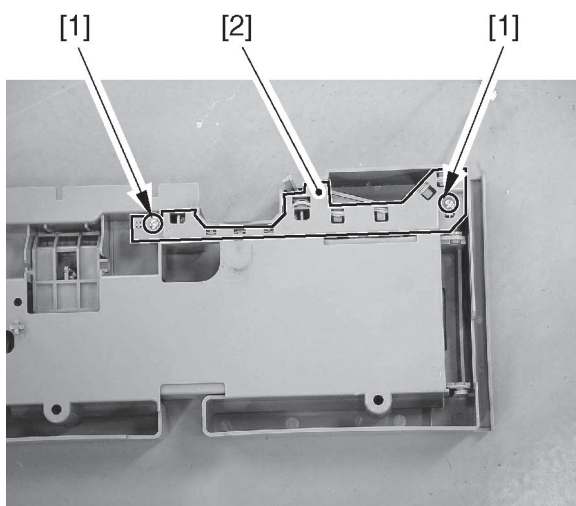

F04-613-07

- 7) Detach the waste toner detection PCB [1] from the cover, and disconnect the connector [2] for replacement.

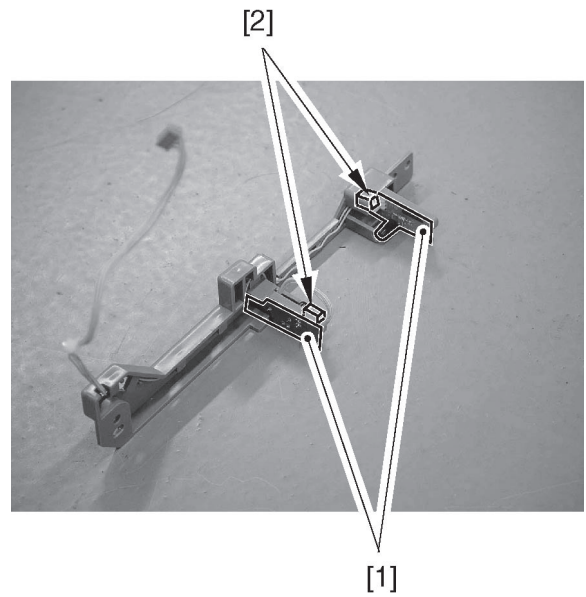

F04-613-08

6.14 Removing the Developer Motor (YMC)

- 1) Open the main controller box. (See 5.26 ‘Removing the Relay PCB 1’ in Chapter 7.)
- 2) Remove the DC controller PCB together with its base. (See 5.21 ‘Removing the DC Controller PCB’ in Chapter 7.)
- 3) Remove the 2 screws [1], and detach the main controller base [2].

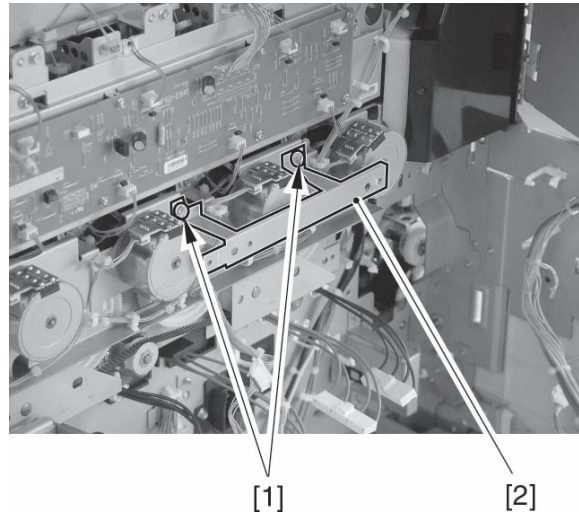

F04-614-01

- 4) Remove the 2 screws [1], and disconnect the connector [2]; then, detach the developer motor [3] (starting at the right, Y, M, and C in sequence).

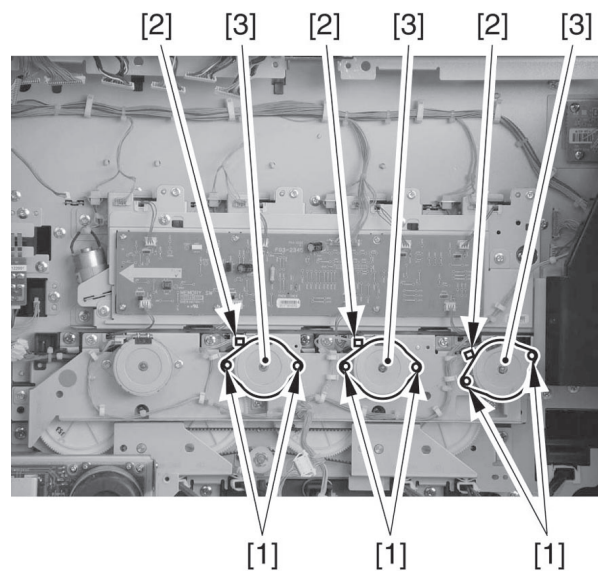

F04-614-02

6.15 Removing the Developer Motor (Bk)

- 1) Open the main controller box. (See 5.26 ‘Removing the Relay PCB’ in Chapter 7.)
- 2) Remove the DC controller PCB together with its base. (See 5.21 ‘Removing the DC Controller PCB’ in Chapter 7.)
- 3) Remove the 2 screws [1], and disconnect the connector [2]; then, detach the developer motor (Bk) [3].

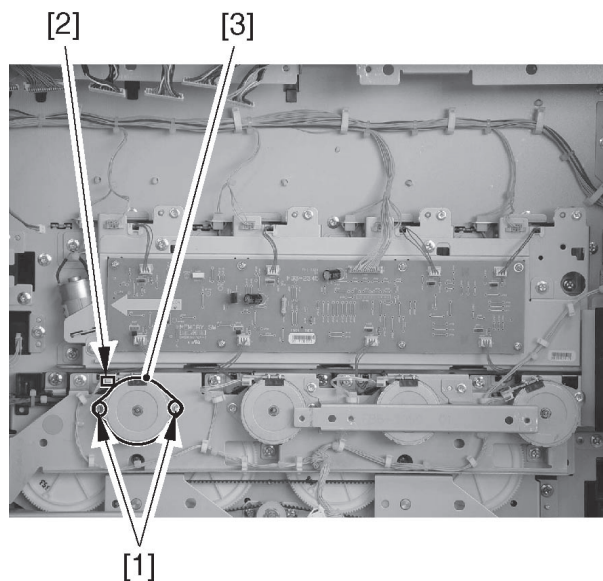

F04-615-01

6.16 Removing the Toner Container Drive Unit

- 1) Open the machine's front cover, and pull out the toner container.
- 2) Open the main controller box. (See 5.26 'Removing the Relay PCB 1' in Chapter 7.)
- 3) Remove the DC controller PCB together with its base. (See 5.21 'Removing the DC Controller PCB' in Chapter 7.)
- 4) Disconnect the connector from the relay PCB 1, and feed the harness of the developer motor from the cable clamp; then, remove the 4 screws [1], and detach the relay PCB 1 together with its base [2].

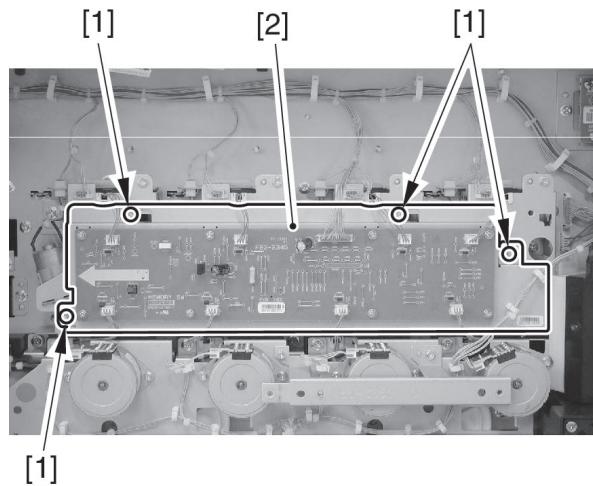

F04-616-01

- 5) Disconnect the 2 connectors [1], and remove the 3 screws [2]; then, detach the toner container drive unit [3].

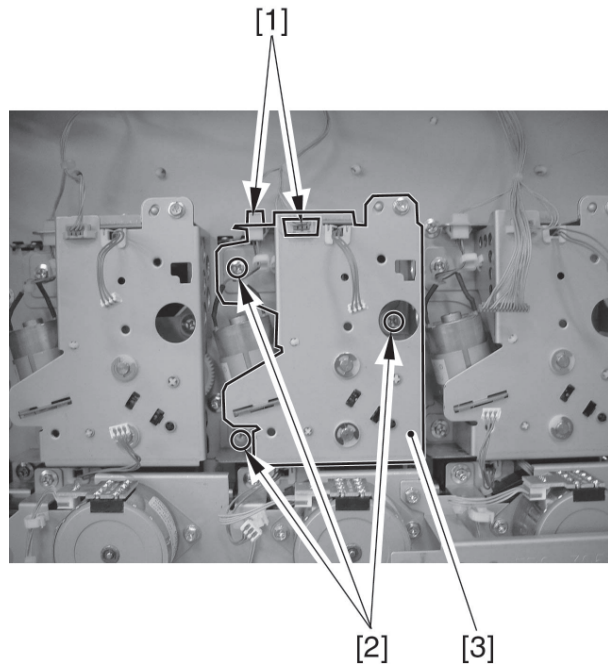

F04-616-02

6.17 Removing the Toner Container Motor

- 1) Remove the toner container drive unit.
(See 6.16 'Removing the Toner Container Drive Unit.')
- 2) Remove the screw [1], 2 E-rings [2], and 2 bushings [3]; then, free the harness from the edge saddle [4]; then, free the harness [5] of the toner container motor from the cord clamp [6] to detach the toner container drive assembly top plate [7].

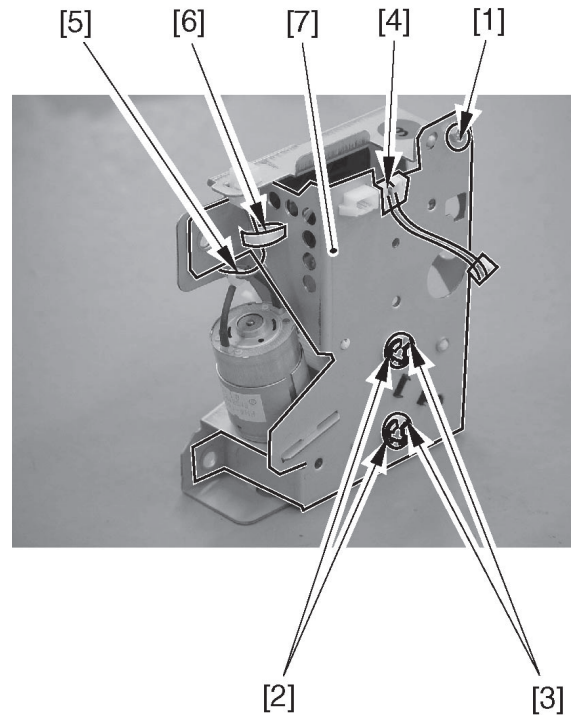

F04-617-01

- 3) Remove the gear [2] that is engaged with the gear [1] found at the tip of the toner container motor.

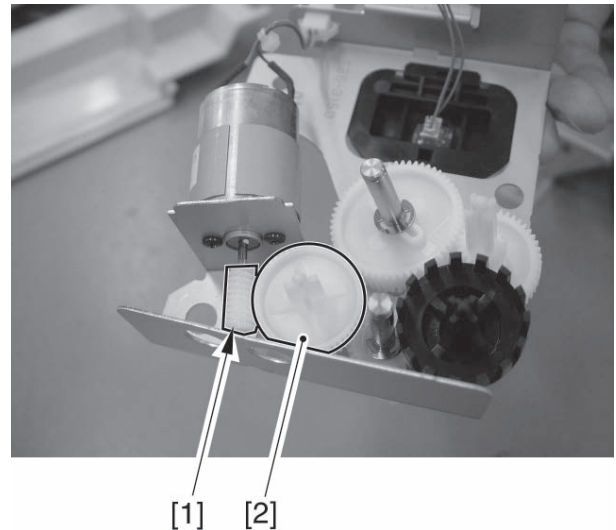

F04-617-02

- 4) Remove the 2 screws [1], and disconnect the connector [2]; then, detach the toner container motor [3].

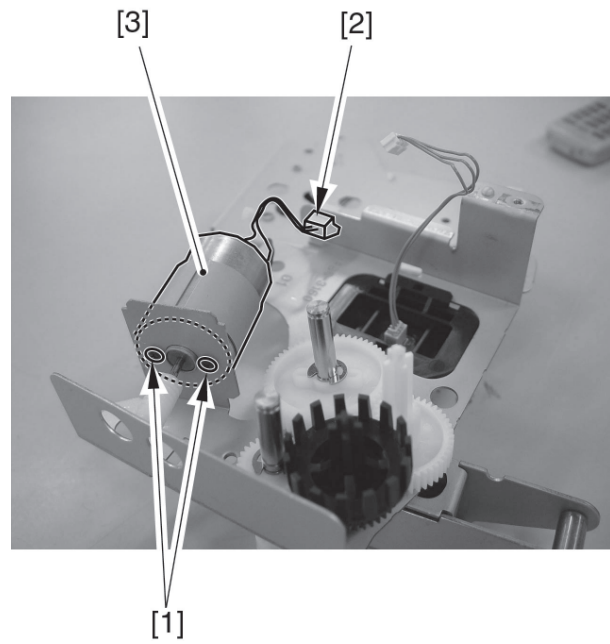

F04-617-03

6.18 Removing the Feedscrew Rotation Sensor

- 1) Remove the toner container drive unit.
(See 6.16 'Removing the Toner Container Drive Unit.')
- 2) Remove the toner container drive assembly top plate. (See step 2) of 6.17 'Removing the Toner Container Motor.')
- 3)



When mounting the top plate, check to be sure to fit the edge of the idler gear [1] after matching it against the hole [2] in the top plate and the hole [3] in the bottom plate.

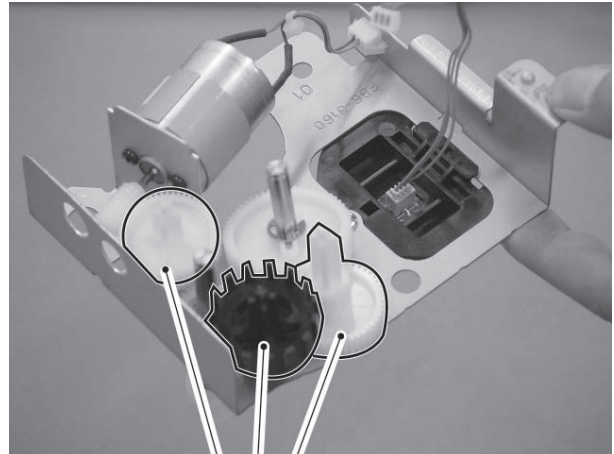

[1]

F04-618-01

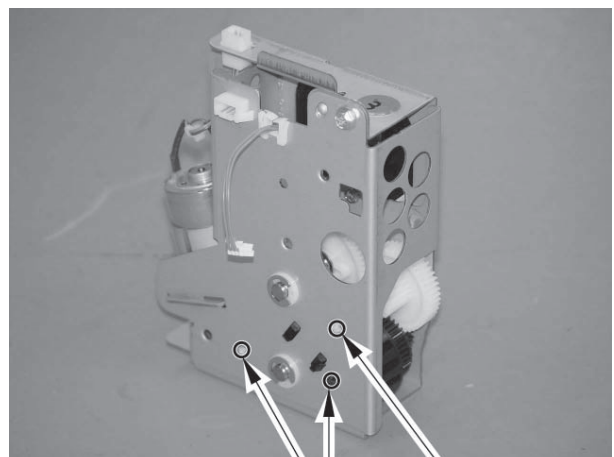

[2]

[2]

F04-618-02

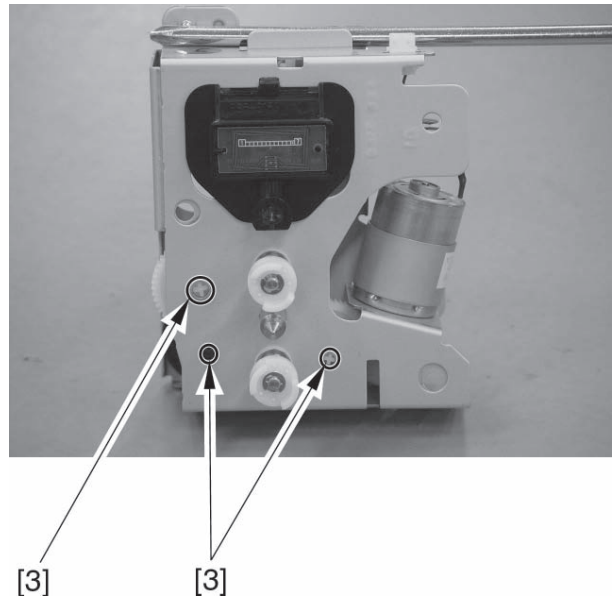

F04-618-03

- 4) Disconnect the connector [1], and remove the feedscrew rotation sensor [2].

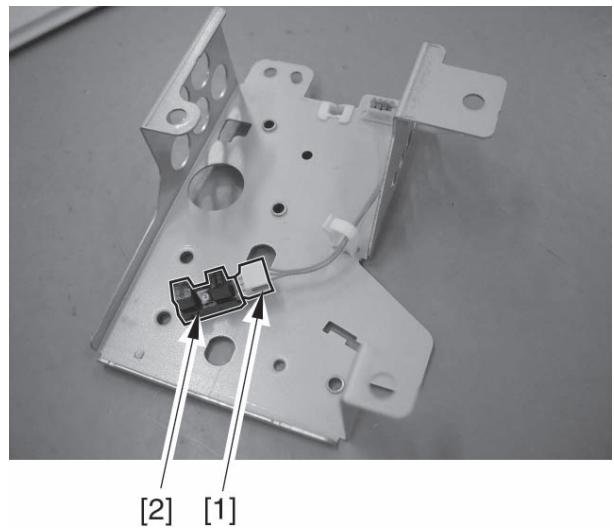

F04-618-04

6.19 Removing the Drum ITB Motor

- 1) Slide out the drum unit to the front.
- 2) Open the main controller box. (See 5.26 'Removing Relay PCB 1' in Chapter 7.)
- 3) Remove the DC controller PCB together with its base. (See 5.21 'Removing the DC Controller PCB' in Chapter 7.)
- 4) Remove the developing drive unit. (See 5.4 'Removing the Developer Drive Unit' in Chapter 7.)
- 5) Remove the 2 screws [1], and disconnect all connectors; then, detach the lattice connector base [2].

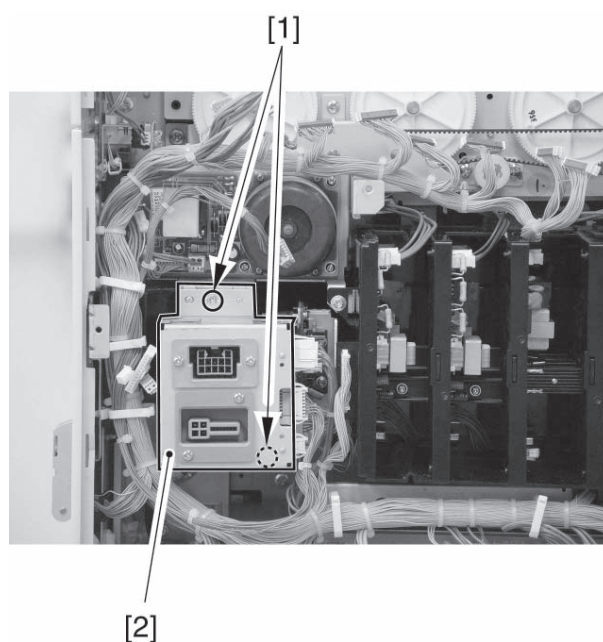

F04-619-01

- 6) Remove the high-voltage unit. (See 5.2 'Removing the High-Voltage Unit' in Chapter 7.)

- 7) Slide out the manual feed unit; then, disconnect the connector [1] and remove the 2 screws [2] to detach the manual feed cooling fan duct [3].

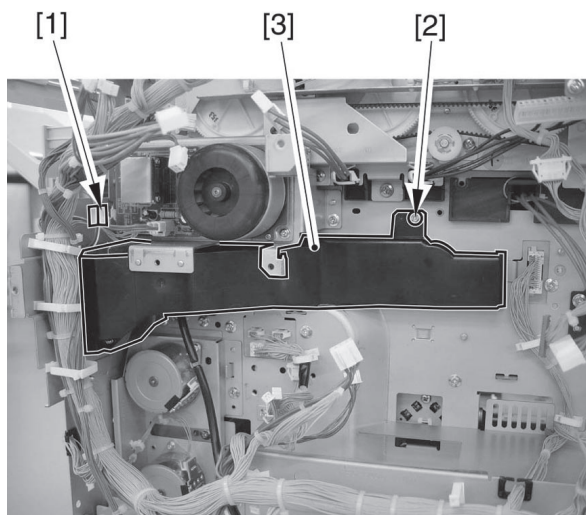

F04-619-02

- 8) Free the DC harness [1] found at the front of the drum ITB motor base from the cable clamp [2].

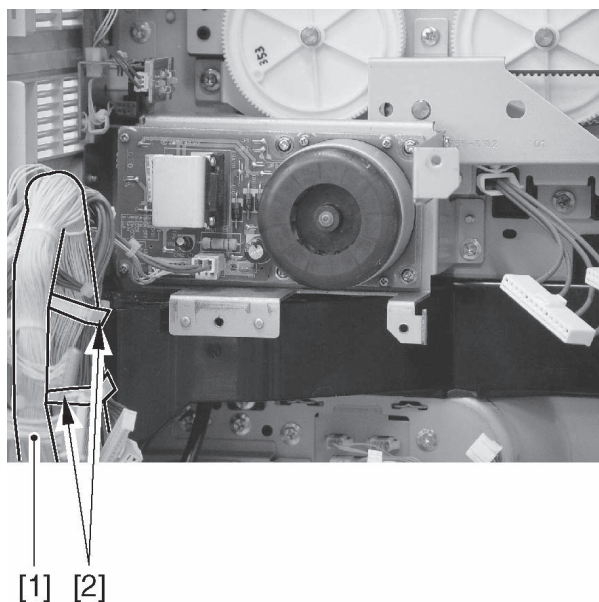

F04-619-03

- 9) Disconnect the 2 connectors [1], and remove the 3 screws [2]; then, detach the drum ITB motor base [3].

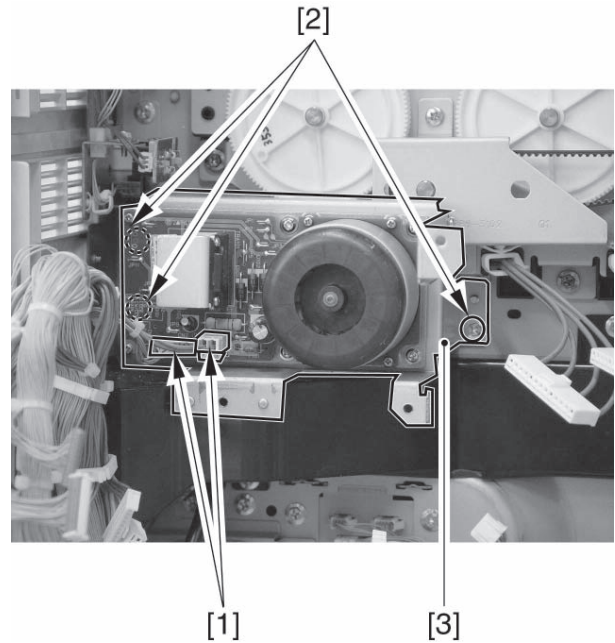

F04-619-04



To remove, put your hand where you have slid out the manual feed unit; then, while holding down the swing plate [1] found to the rear of the drum drive unit, remove from the machine's rear side plate.

The drum drive unit is hooked on the protrusion from the rear side plate; lift it slightly to detach.

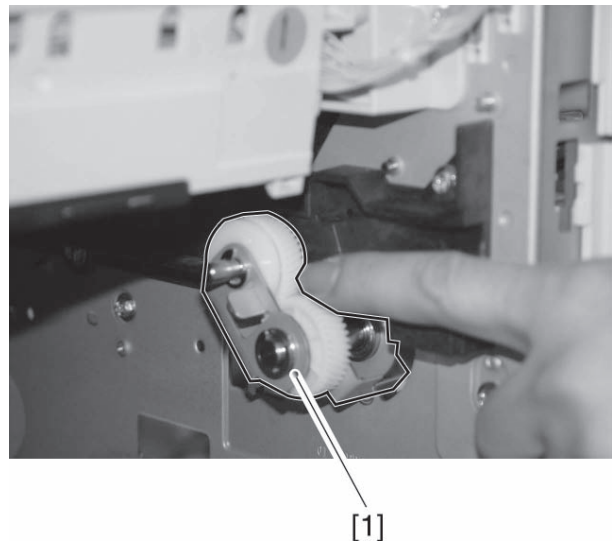

F04-619-05

- 10) Remove the 4 screws [1], and detach the drum ITB motor [2].

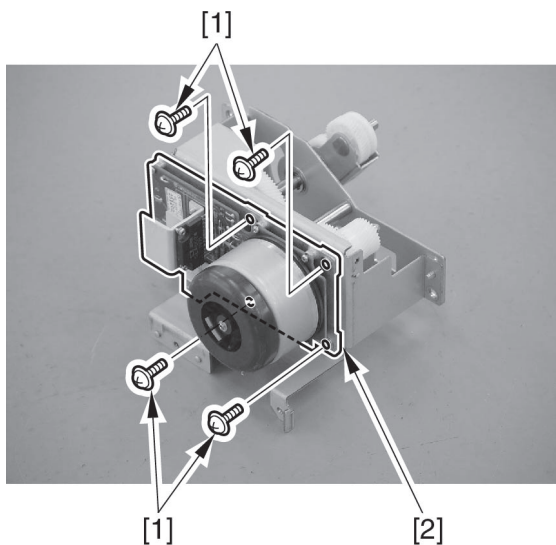

F04-619-06

6.20 Removing the Drum Drive Unit

- 1) Remove the drum ITB motor. (See 6.19 ‘Removing the Drum ITB Motor.’)
- 2) Disconnect the 6 connectors [1], and remove the 7 screws [2]: then, take out the drum drive unit [3].

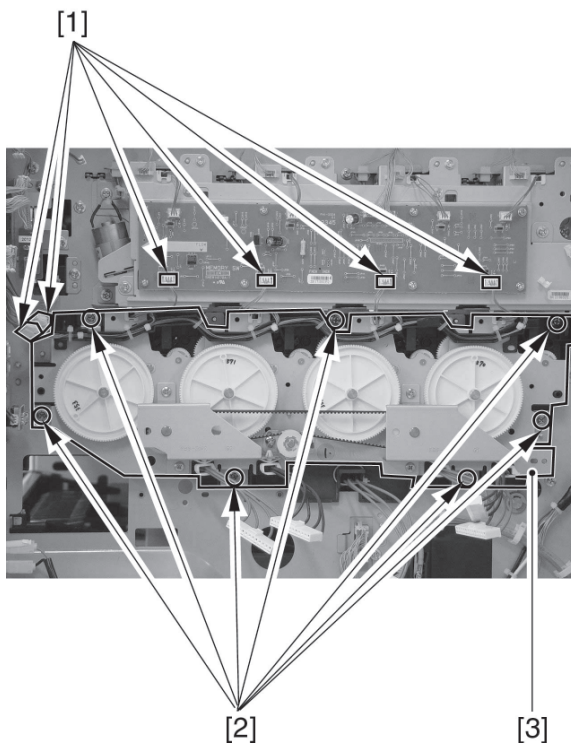

F04-620-01

6.21 Removing the Transfer Cleaning Unit

- 1) Open the front cover, and turn the intermediate transfer unit releasing lever [1] to unlock; then, detach the waste toner container [2].

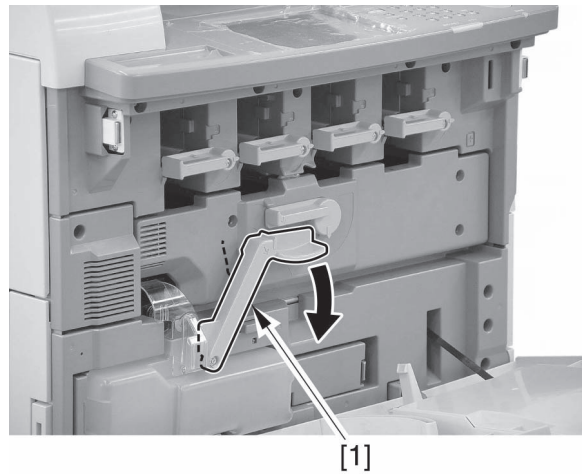

F04-621-01

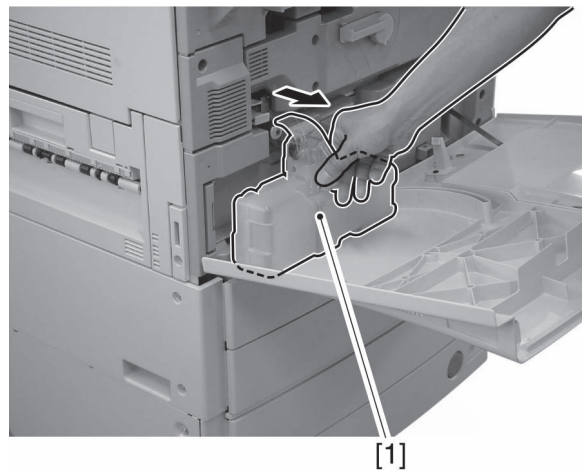

F04-621-01

- 2) Remove the screw [1], and detach the transfer cleaning unit [2].

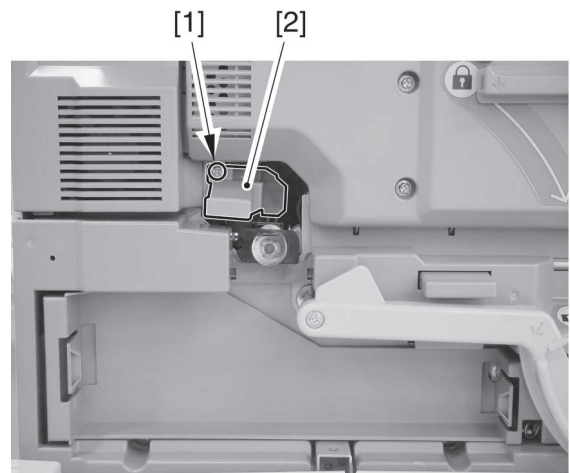

F04-621-03

CHAPTER 5

PICKUP AND FEEDING

1 Outline of Operation

1.1 Specifications, Control Mechanisms, and Functions

The major specifications, control mechanisms, and functions of the pickup feeder system are as follows:

Item	Description	
Method of paper accommodation	Front loading	
Method of pickup	Separation retard	
Paper feed reference	Center	
Size of paper accommodation	Cassette 1/2	550 sheets (80 g/m ²)
	Manual feed tray	100 sheets (80 g/m ²)
Size of paper	Cassette 1/2	A3, A4, A4R, B4, B5, B5R, A5R, 12x18, 11x17, LGL, LTR, LTRR, STMTR
	Manual feed tray	98 to 320 mm (main scanning direction) 148 to 457.2 mm (sub scanning direction)
Type of paper	Plain paper, thick paper, transparency	64 g/m ² to 209 g/m ² (from cassette) 64 g/m ² to 253 g/m ² (from manual feeder)
Paper size switching	Cassette 1/2	by user
	Manual feed tray	by user
Duplex print	Through path	

T05-101-01

1.2 Major Components

1.2.1 Arrangement of the Units

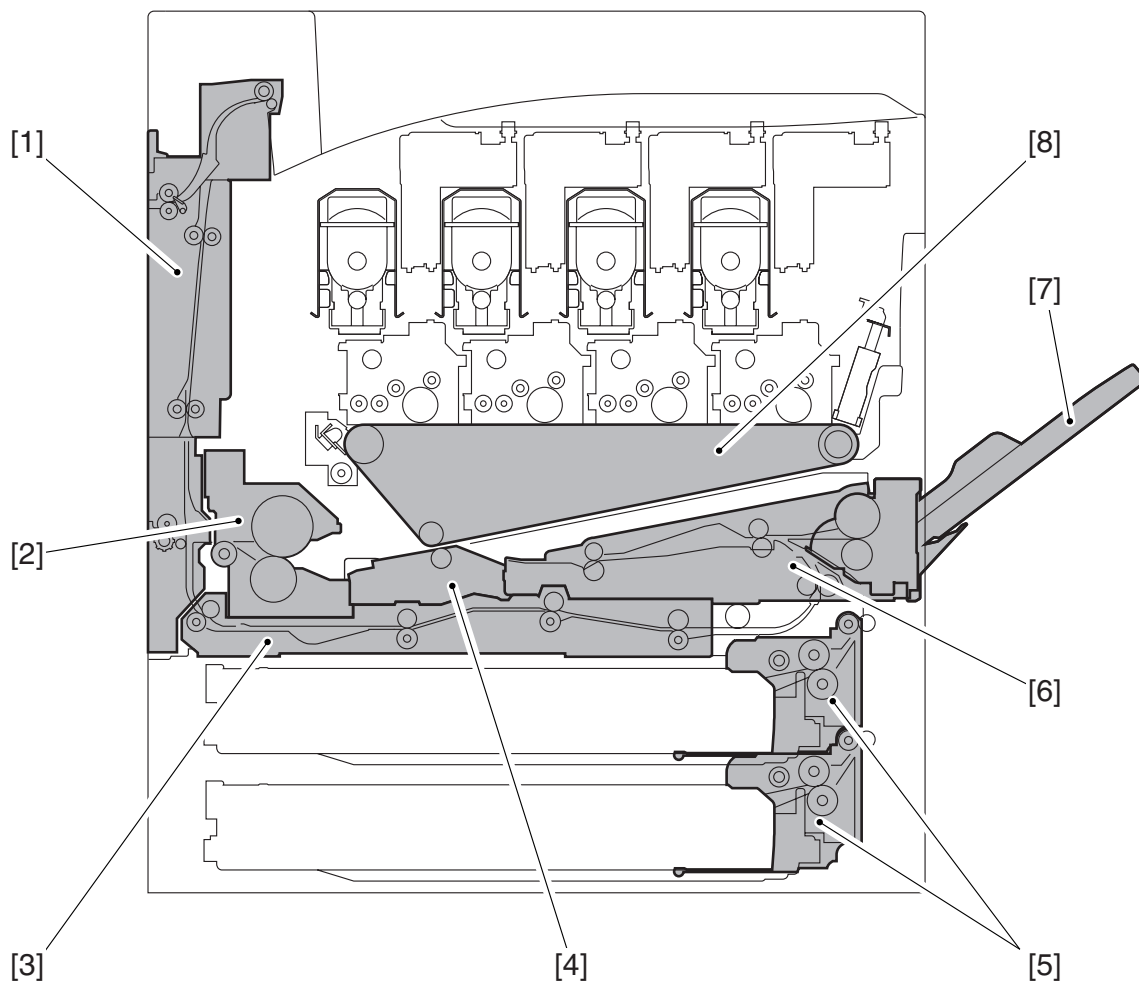

F05-102-01

- [1] Delivery assembly
- [2] Fixing unit
- [3] Duplex unit
- [4] Secondary transfer unit

- [5] Pickup unit
- [6] Registration unit
- [7] Manual feed unit
- [8] Intermediate transfer unit

1.2.2 Arrangement of Rollers

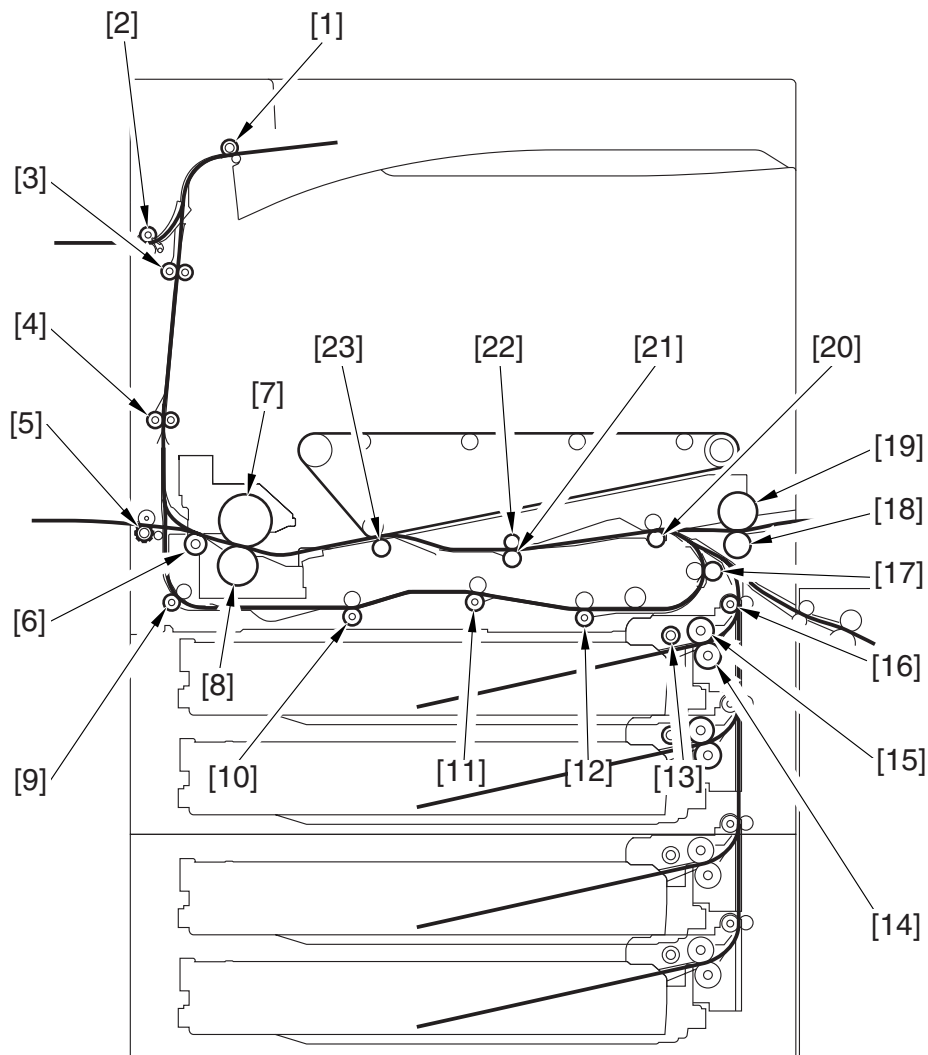

F05-102-02

- | | |
|---|------------------------------------|
| [1] Face-down delivery roller 1 | [13] Pickup roller |
| [2] Face-down delivery roller 2 | [14] Separation roller |
| [3] Delivery vertical path roller 1 | [15] Feed roller |
| [4] Delivery vertical path roller 2 | [16] Pickup vertical path roller |
| [5] Face-up delivery roller | [17] Re-pickup roller |
| [6] Internal delivery roller | [18] Manual feed separation roller |
| [7] Fixing roller (fixing upper roller) | [19] Manual feed roller |
| [8] Pressure roller (fixing lower roller) | [20] Pre-registration roller |
| [9] Duplex roller 1 | [21] Lower registration roller |
| [10] Duplex roller 2 | [22] Upper registration roller |
| [11] Duplex roller 3 | [23] Secondary transfer roller |
| [12] Duplex roller 4 | |

1.2.3 Diagram of the Paper Paths

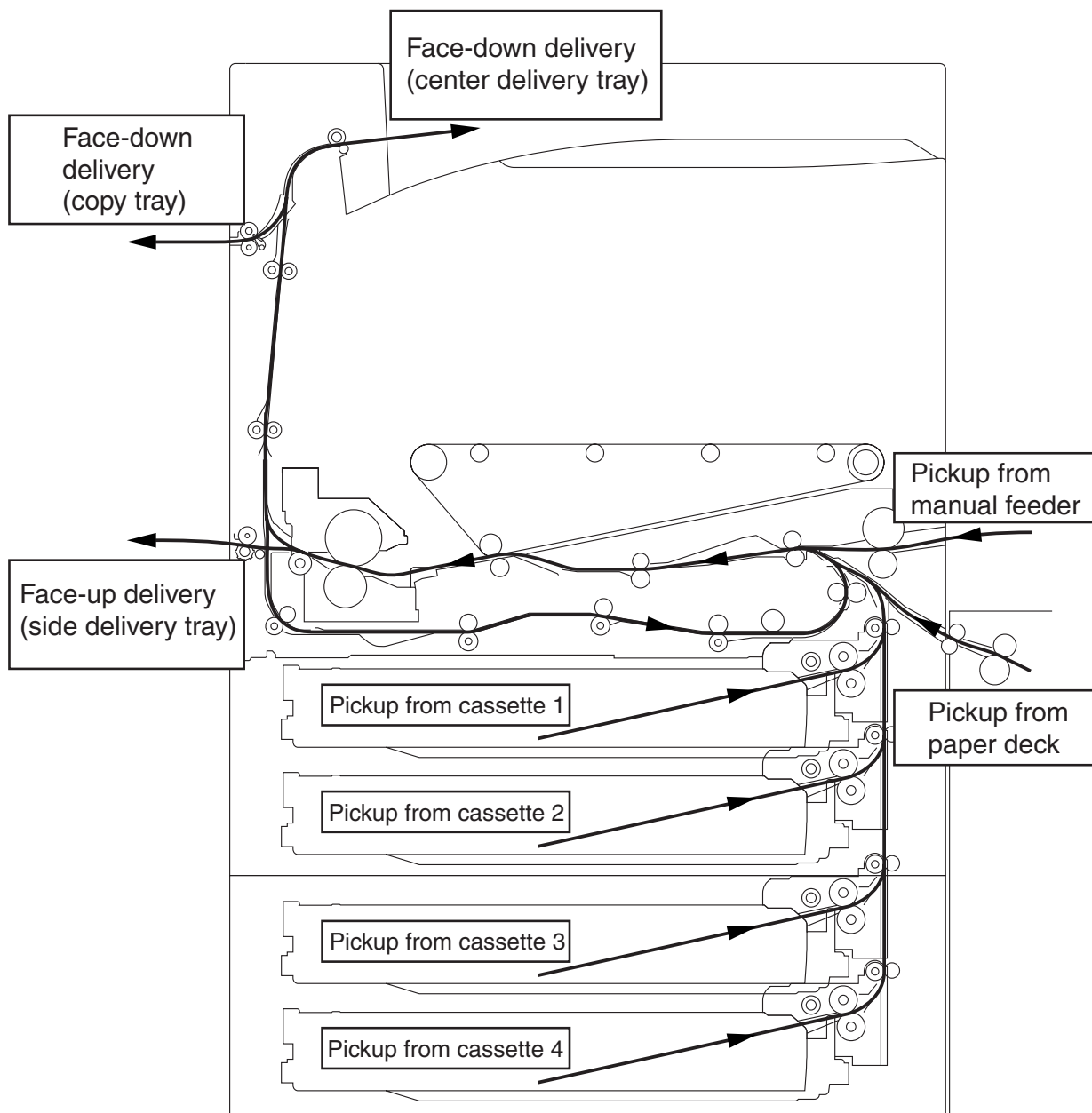

F05-102-03

1.2.4 Arrangement of Sensors

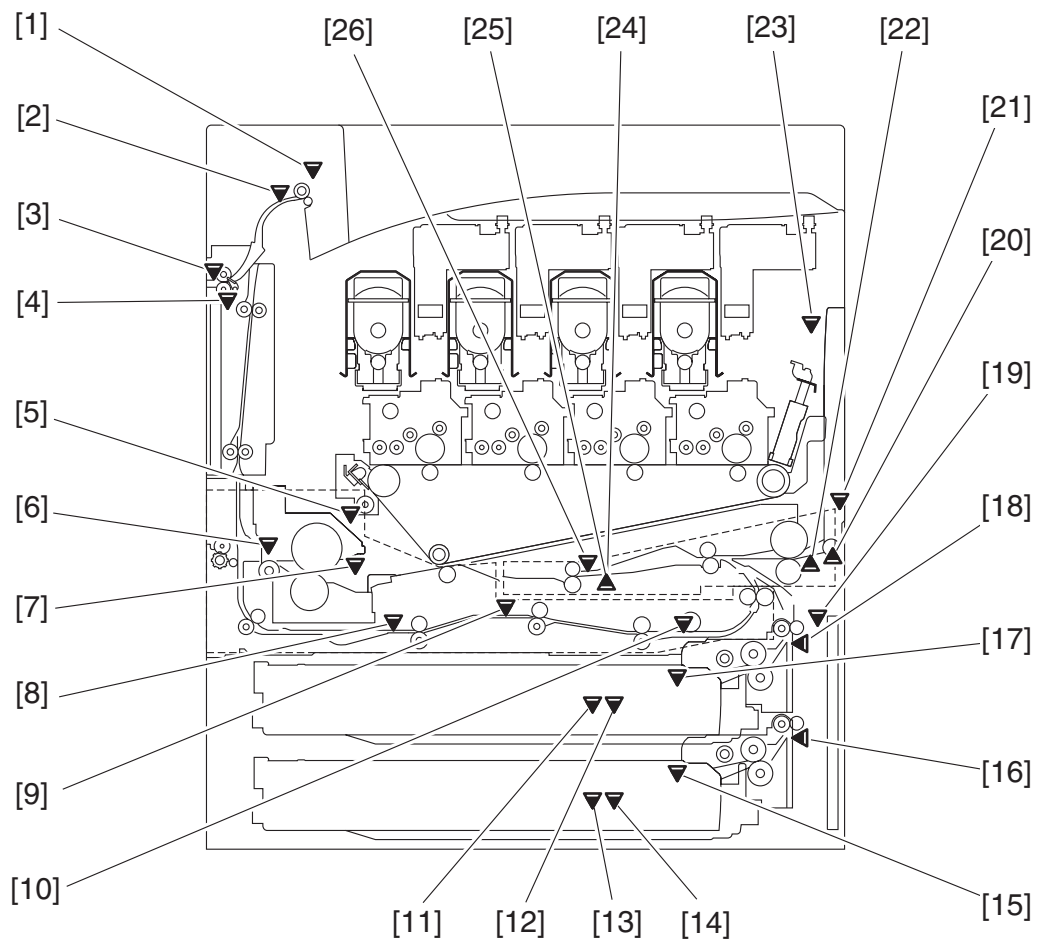

F05-102-04

- | | |
|--|---|
| [1] Center delivery tray full sensor (PS8) | [14] Cassette 2 paper level sensor (A; PS20) |
| [2] Face-down delivery sensor 1 (PS12) | [15] Cassette 2 paper sensor (PS19) |
| [3] Face-down delivery sensor 2 (PS6) | [16] Cassette 2 retry paper sensor (PS17) |
| [4] Delivery vertical path cover open/closed sensor (PS13) | [17] Cassette 1 paper sensor (PS7) |
| [5] Fixing feeder unit open/closed sensor (PS5) | [18] Cassette 1 retry paper sensor (PS16) |
| [6] Fixing delivery sensor (PS25) | [19] Pickup vertical path cover open/closed sensor (PS11) |
| [7] Fixing inlet sensor (PS27) | [20] Manual feed last paper sensor (PS9) |
| [8] Duplex registration sensor (PS21) | [21] Manual feed unit open/closed sensor (PS28) |
| [9] Duplex horizontal registration sensor (PS22) | [22] Manual feed paper sensor (PS10) |
| [10] Duplex pickup sensor (PS24) | [23] Front cover open/closed sensor (PS23) |
| [11] Cassette 1 paper level sensor (B; PS15) | [24] Transparency sensor (front; OHP1) |
| [12] Cassette 1 paper level sensor (A; PS14) | [25] Transparency sensor (rear; OHP2) |
| [13] Cassette 2 paper level sensor (B; PS18) | [26] Registration sensor (PS26) |

1.2.5 Arrangement of the Clutches and Solenoids

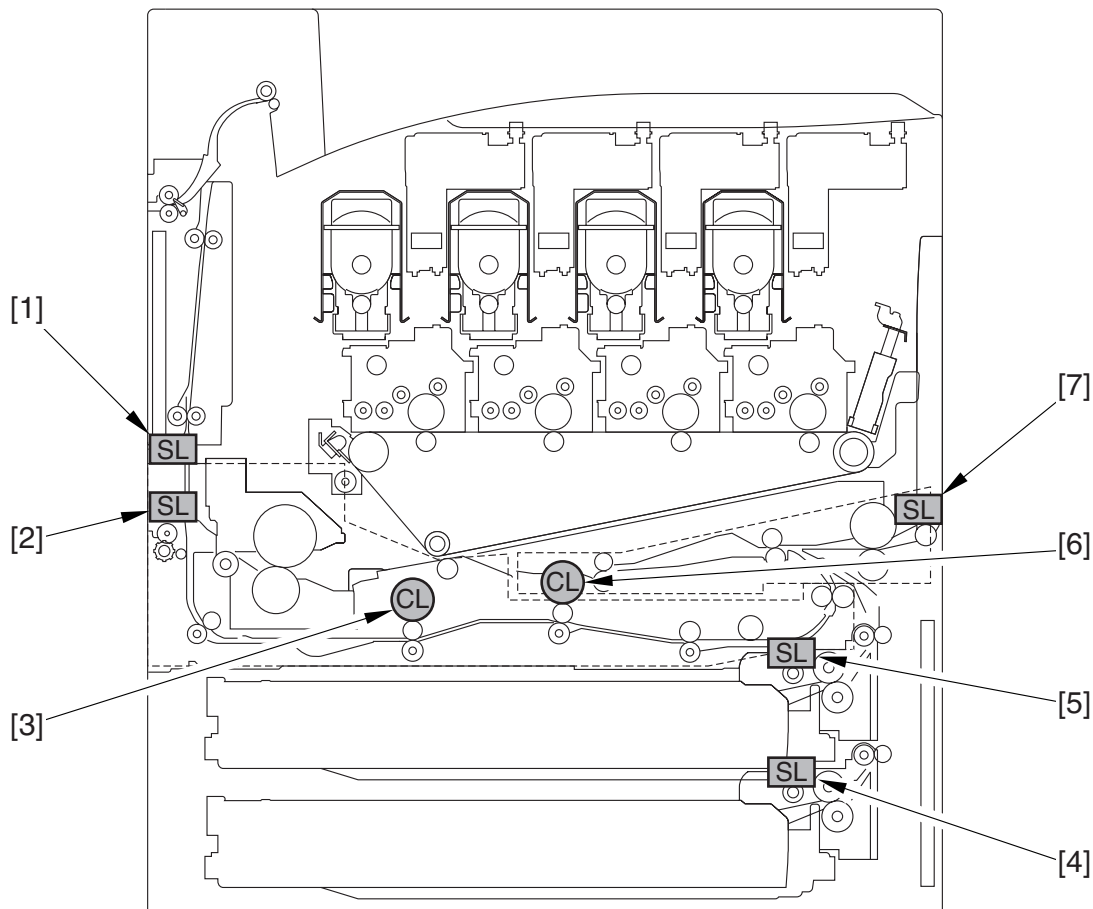

F05-102-05

- [1] Delivery path switching solenoid 1 (SL2)
- [2] Delivery path switching solenoid 2 (SL5)
- [3] Duplex registration clutch (CL1)
- [4] Cassette 2 pickup solenoid (SL4)
- [5] Cassette 1 pickup solenoid (SL3)
- [6] Duplex pickup solenoid (CL2)
- [7] Manual feed pickup solenoid (SL1)

1.2.6 Route of Drive

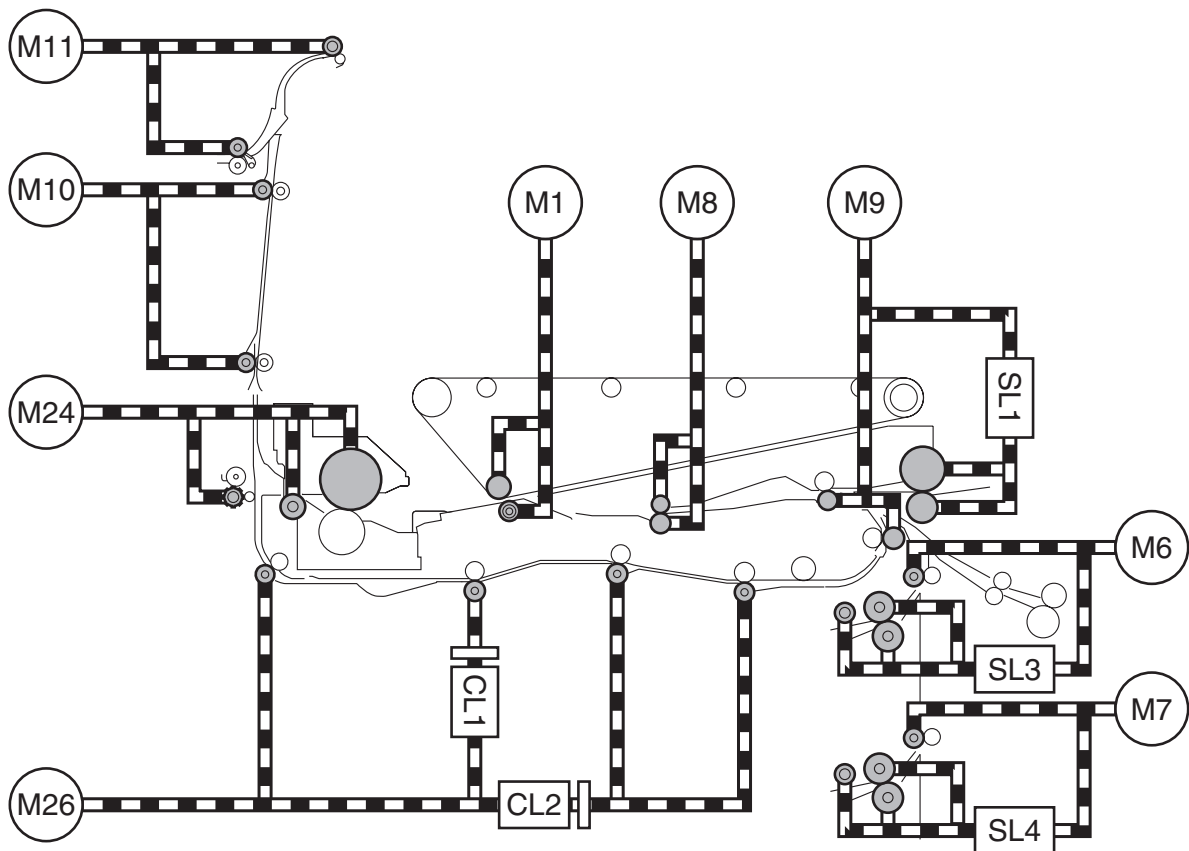

F05-102-06

CL1	duplex registration clutch	M10	delivery vertical path motor
CL2	duplex pickup clutch	M11	face-down delivery motor
M1	drum ITB motor	M24	fixing motor
M6	cassette 1 pickup motor	M26	duplex feed motor
M7	cassette 2 pickup motor	SL1	manual feed pickup solenoid
M8	registration motor	SL3	cassette 1 pickup solenoid
M9	pre-registration motor	SL4	cassette 2 pickup solenoid

1.3 Basic Sequence of Operations

1.3.1 Basic Sequence of Operations at Power-On

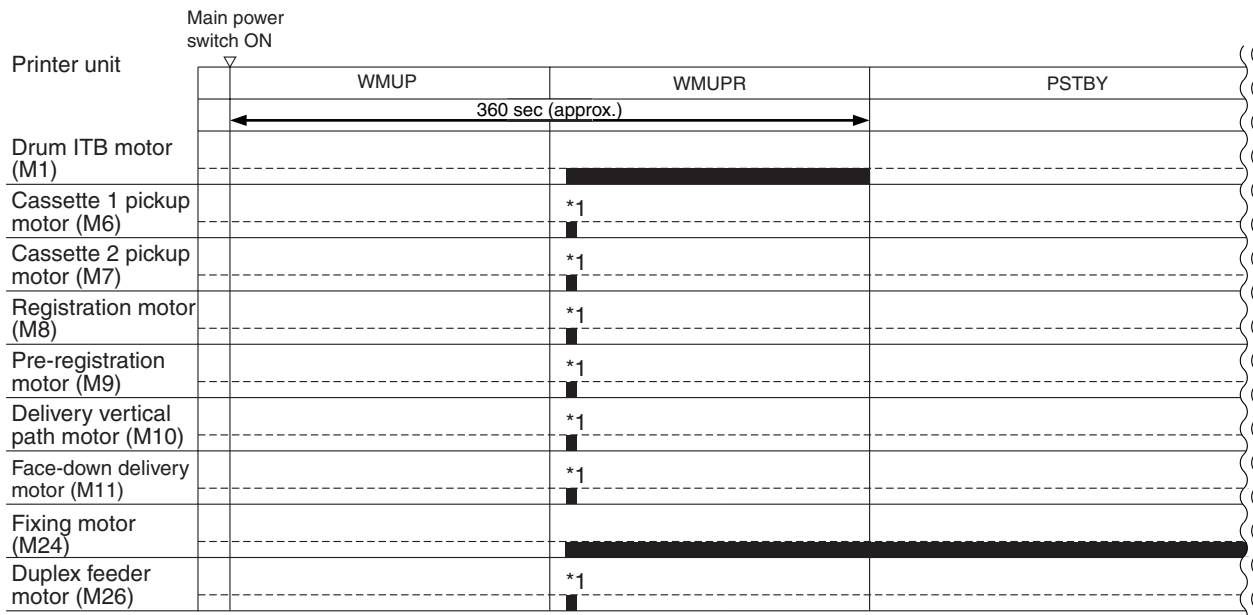

*1: rotates for about 4.0 sec; a stationary jam will be identified if the sensor goes ON during the period.

F05-103-01

1.3.2 Basic Sequence of Operations in Response to a Press on the Start Key

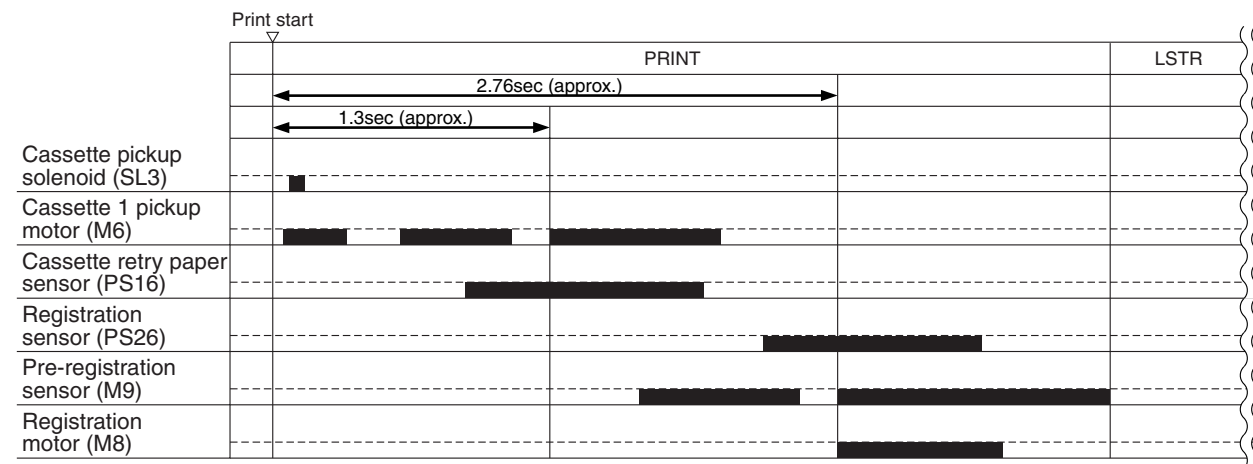

F05-103-02

2 Detecting Jams

2.1 Delivery Jam

2.1.1 Delay Jam in the Cassette Pickup Assembly

The leading edge of paper is not at the sensor within a specific period of time (for feeding) after the motor has gone ON.

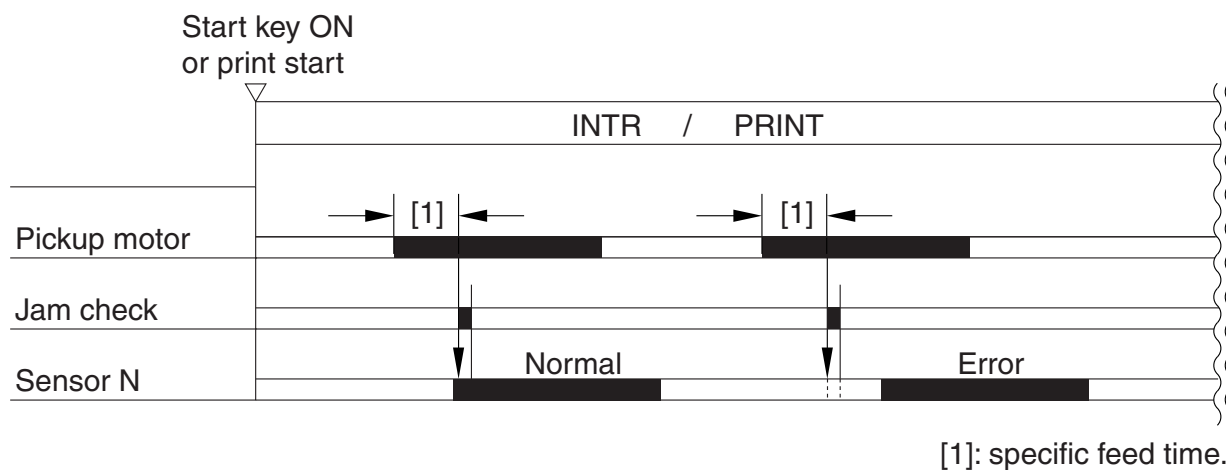

F05-201-01

Source	Motor	Sensor
Cassette 1	Pickup motor (M6)	Cassette 1 retry paper sensor (PS16)
Cassette 2	Pickup motor (M7)	Cassette 2 retry paper sensor (PS17)

2.1.2 Delay Jam Outside the Cassette Pickup Assembly

A delay jam occurring outside the cassette pickup assembly is identified at the following timing:

The period of time during which paper is moved from the sensor N-1 to the delay jam sensor N in question is controlled, and a delay jam will be identified if the delay jam sensor N in question does not go ON within a specific period of time after the sensor N-1 has gone ON.

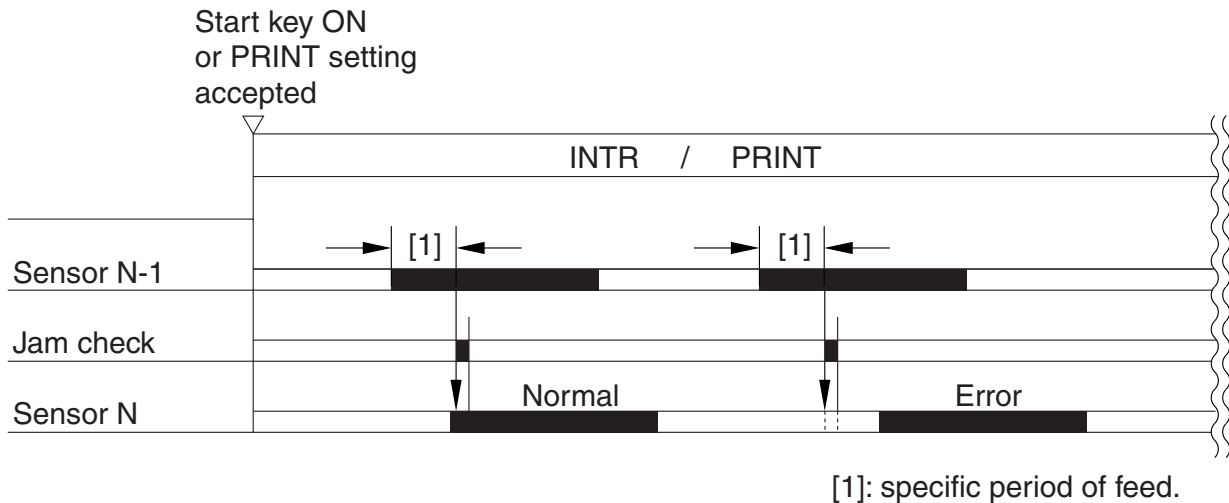

F05-201-02

Sensor

- Registration sensor (PS26)
- Fixing delivery sensor (PS25)
- Face-down delivery sensor 1 (PS12)
- Face-down delivery sensor 2 (PS6)
- Duplex registration sensor (PS21)
- Duplex pickup sensor (PS24)

2.2 Stationary Jams

2.2.1 Common Stationary Jams

A stationary jam will be identified if the sensor N does not go OFF within a specific period of time after the sensor N has gone ON.

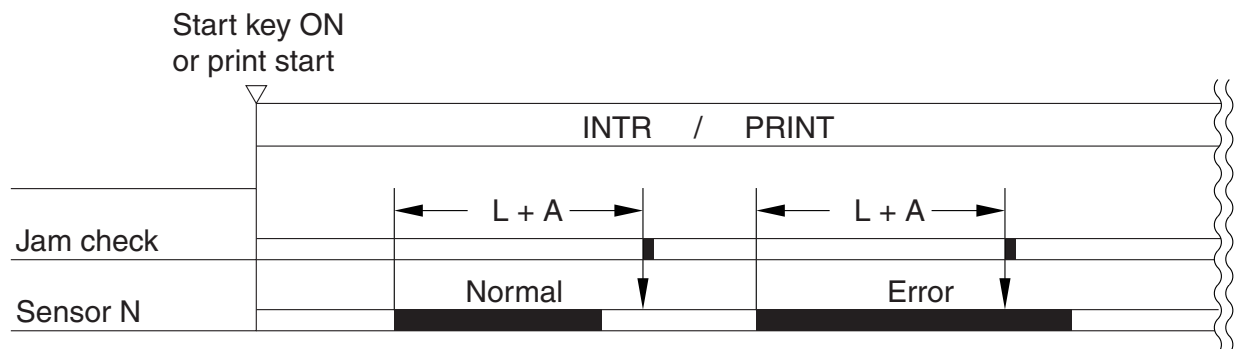

(L = paper length feed distance; A = specific feed distance)

F05-202-01

Sensor

- Cassette 1 retry paper sensor (PS16)
- Cassette 2 retry paper sensor (PS17)
- Registration sensor (PS26)
- Fixing delivery sensor (PS25)
- Face-down delivery sensor 1 (PS12)
- Face-down delivery sensor 2 (PS6)
- Duplex registration sensor (PS21)
- Duplex pickup sensor (PS24)

2.2.2 Stationary Jams at Power-On

The machine checks the absence of paper over the following sensors before it starts initial multiple rotations at power-on:

Sensor

Cassette 1 retry paper sensor (PS16)

Cassette 2 retry paper sensor (PS17)

Registration sensor (PS26)

Fixing delivery sensor (PS25)

Face-down delivery sensor 1 (PS12)

Face-down delivery sensor (PS6)

Duplex registration sensor (PS21)

Duplex pickup sensor (PS24)

3 Cassette

3.1 Identifying the Paper Size

The machine identifies the size of paper in the cassette with reference to the slide guide (15 settings) of the cassette. The 4-in-a-row actuator designed for the identification of the cassette size found on the machine side goes ON/OFF according to the position of the slide guide, permitting the machine to identify 15 settings. In the absence of a cassette, all 4 actuators will go OFF.

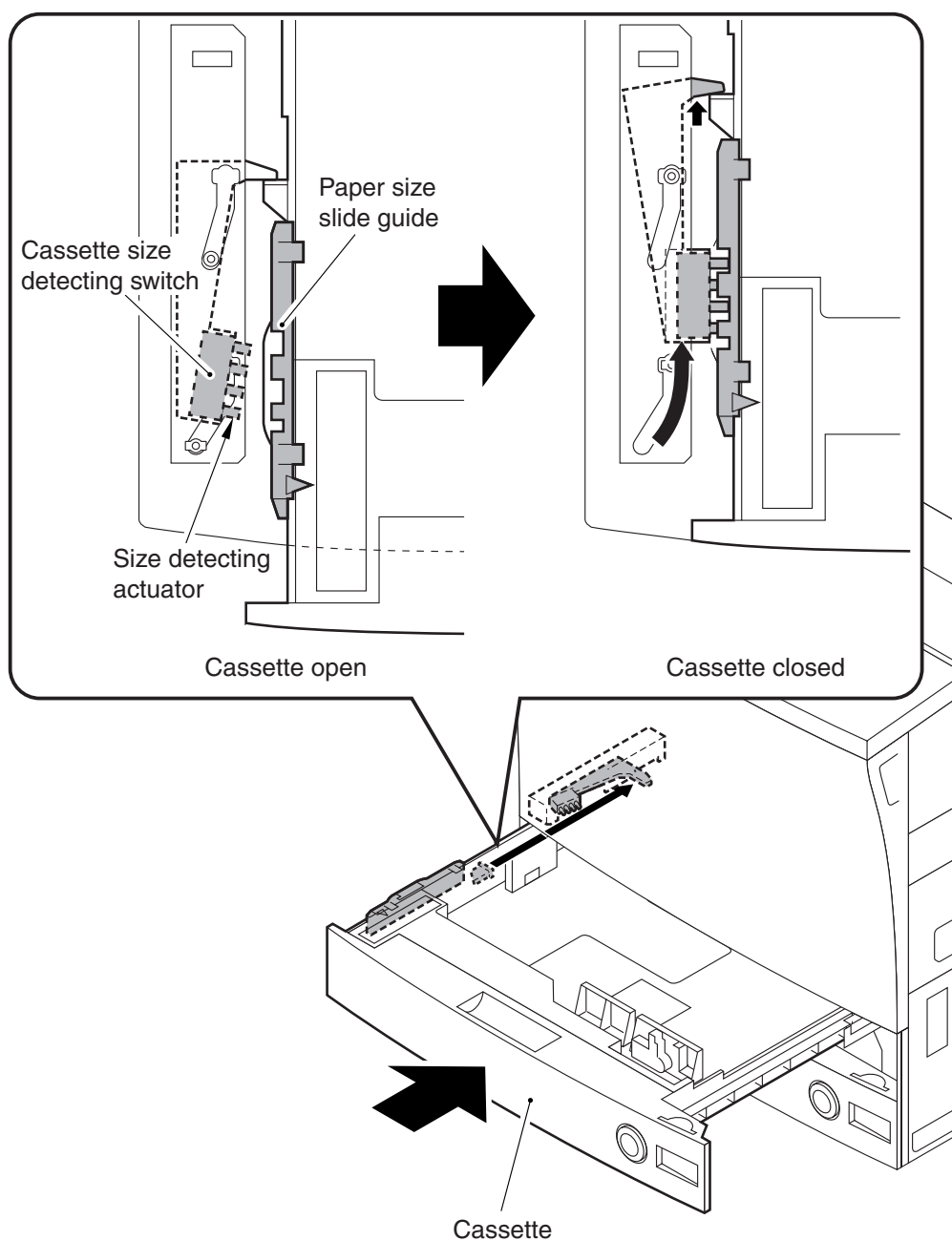

F05-301-01

	Paper size	4-in-a-row actuator			
		Rear		Front	
		Bit3	Bit2	Bit1	Bit0
1	STMT R	ON			
2	LTR		ON		
3	LTR R	ON		ON	
4	LGL		ON		ON
5	11X17			ON	
6	A5 R	ON			ON
7	A4	ON	ON		
8	A4R		ON	ON	
9	A3	ON		ON	ON
10	B5	ON	ON		ON
11	B5 R	ON	ON	ON	
12	B4	ON	ON	ON	ON
13	12X18		ON	ON	ON
14	U1			ON	ON
15	U2				ON
16	no cassette				

ON: actuator pressed (i.e., '0' in reference to a check in I/O mode).

T05-301-01

3.2 Detecting the Level of Paper

The level of paper inside the cassette is detected using the following three sensors:

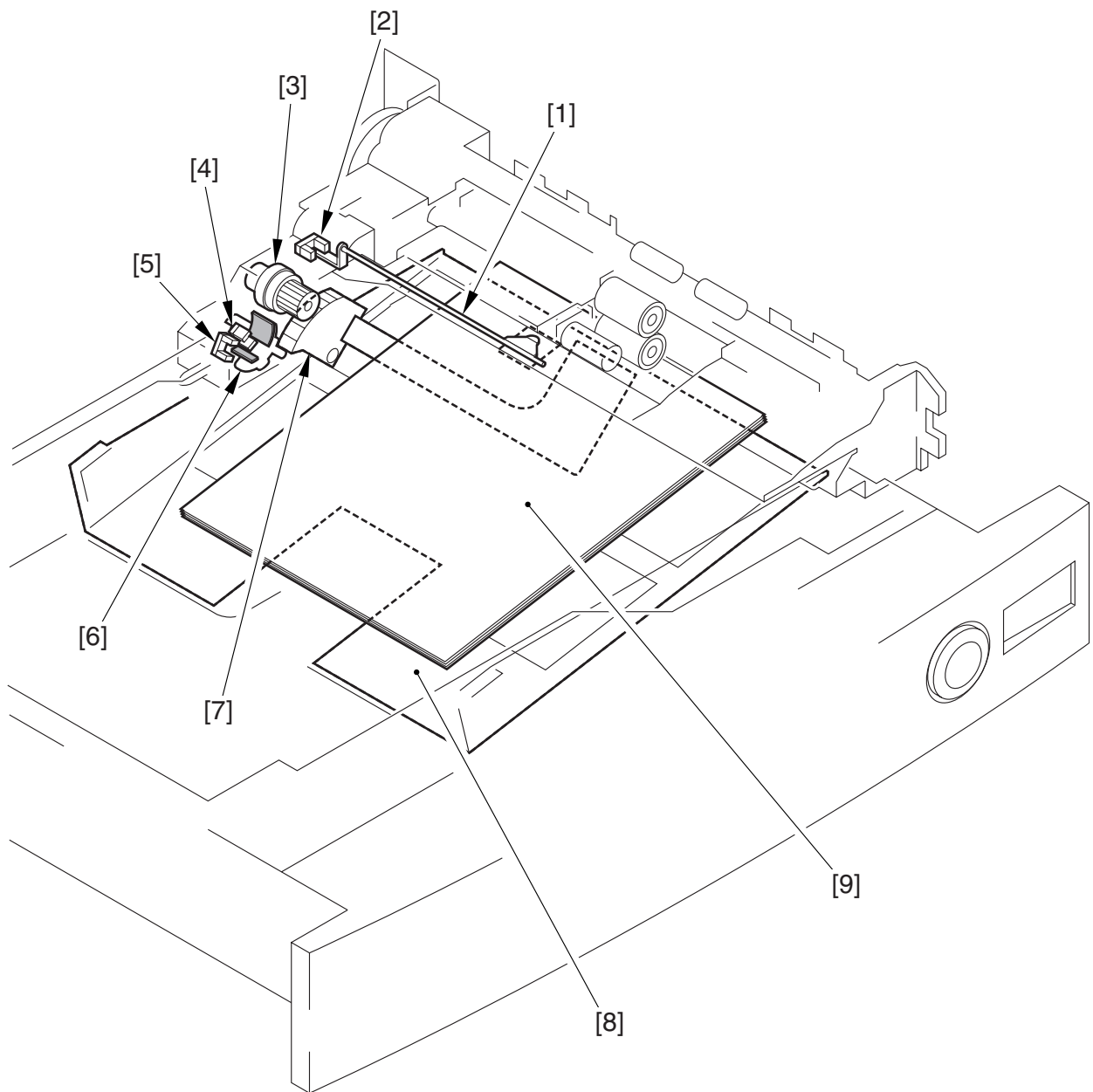

F05-302-01

- | | |
|-------------------------------------|-----------------------------|
| [1] Flag | [6] Paper level sensor flag |
| [2] Cassette paper sensor | [7] Lifter |
| [3] Gear | [8] Tray |
| [4] Cassette paper level sensor (A) | [9] Paper |
| [5] Cassette paper level sensor (B) | |

View from the Front of the Machine

If the cassette is full of paper

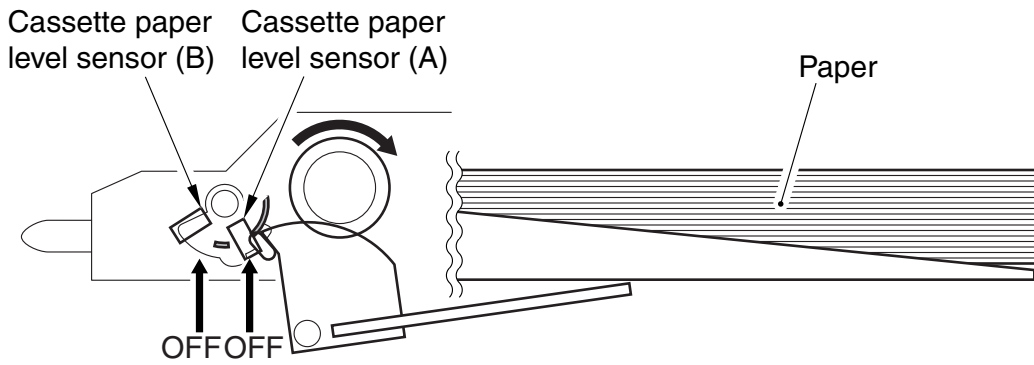

If the cassette is half full of paper

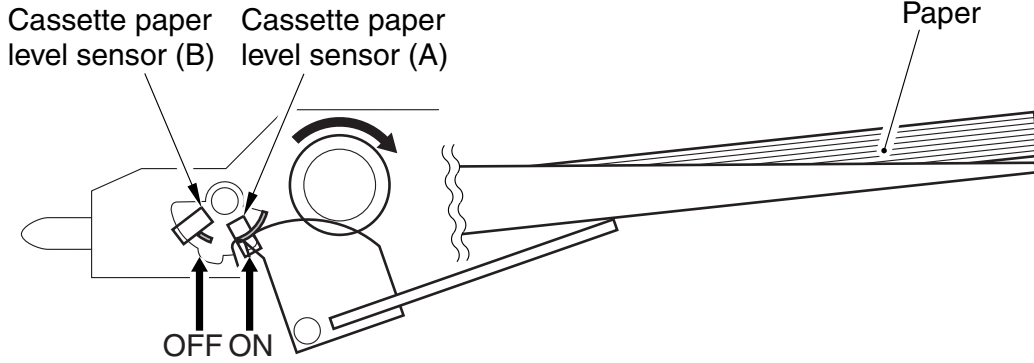



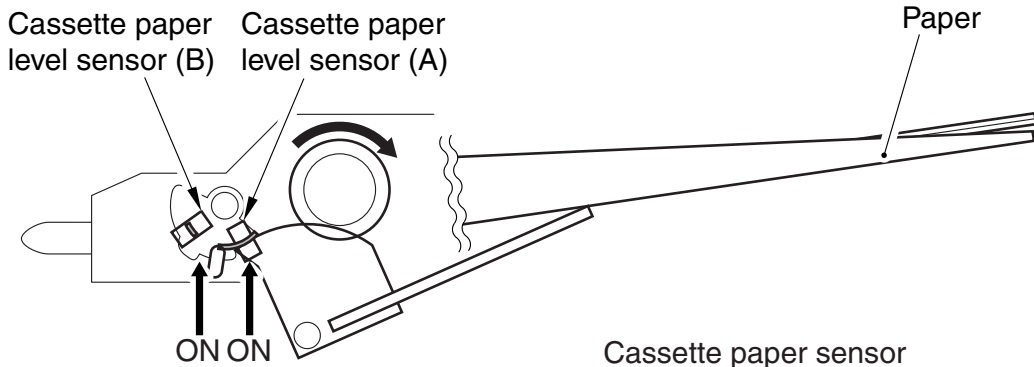

If the cassette has little paper

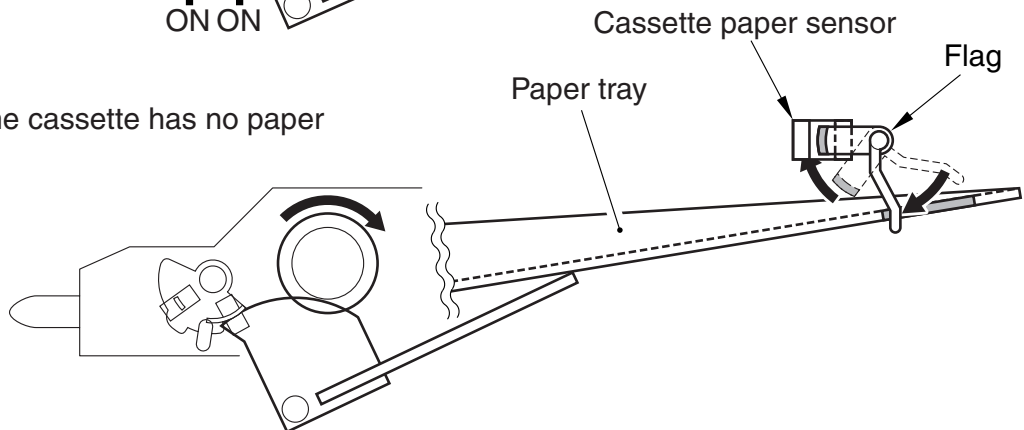

If the cassette has no paper



F05-302-02

Paper level sensor (A)	Paper level sensor (B)	Paper sensor	Level of paper	Indication on control panel
off	off	off	100% to 50% of capacity	
ON	off	off	about 50% to about 50 sheets	
ON	ON	off	About 50 sheets or less	
---	---	ON	No paper	

ON: Sensor's light is obstructed (i.e., '1' in reference to a check in I/O mode.)

T05-302-01

3.3 Cassette Pickup Unit

3.3.1 Outline

The paper inside the cassette is held up by the lifter plate, and the pickup roller is brought down to the paper for pickup.

The feed roller and the separation roller are used to make sure that no more than a single sheet of paper is moved to the feeding assembly; the pickup vertical path roller/pre-registration roller is then used to move the paper as far as the registration roller (upper, lower).

The pickup vertical path roller and the pre-registration roller are each driven by the pickup 1 motor and the pre-registration motor, respectively.

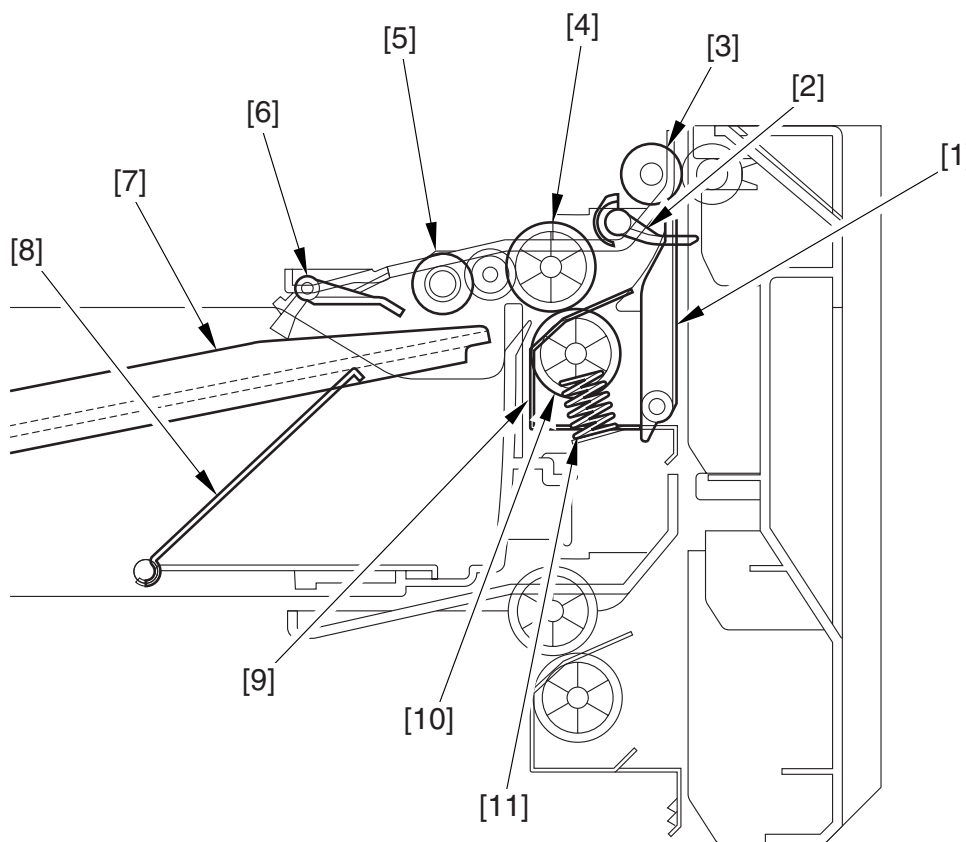

F05-303-01

- | | |
|---------------------------------|-----------------------------------|
| [1] Vertical path guide | [7] Holding plate |
| [2] Cassette retry paper sensor | [8] Lifter plate |
| [3] Pickup vertical path roller | [9] Retard guide |
| [4] Feed roller (roller B) | [10] Separation roller (roller C) |
| [5] Pickup roller (roller A) | [11] Retard spring |
| [6] Cassette paper sensor | |

3.3.2 Basic Sequence of Operations

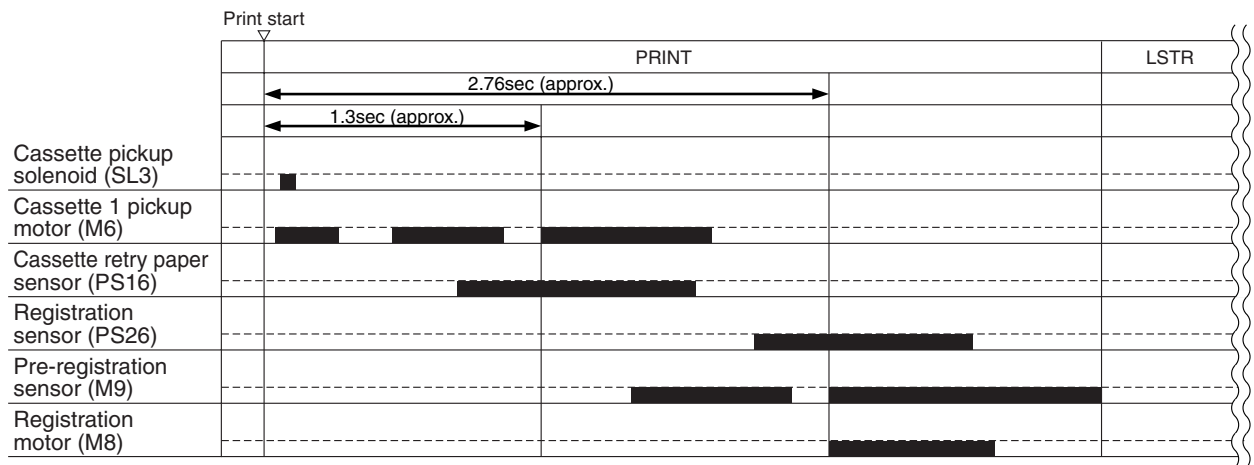

F05-303-02

4 Manual Feed Pickup Unit

4.1 Ohtine

The paper in the manual feed pickup unit is forced against the pickup feeder roller as the lifter moves up, and a single sheet of paper is separated and moved ahead by the work of the pickup feeder roller and the separation roller.

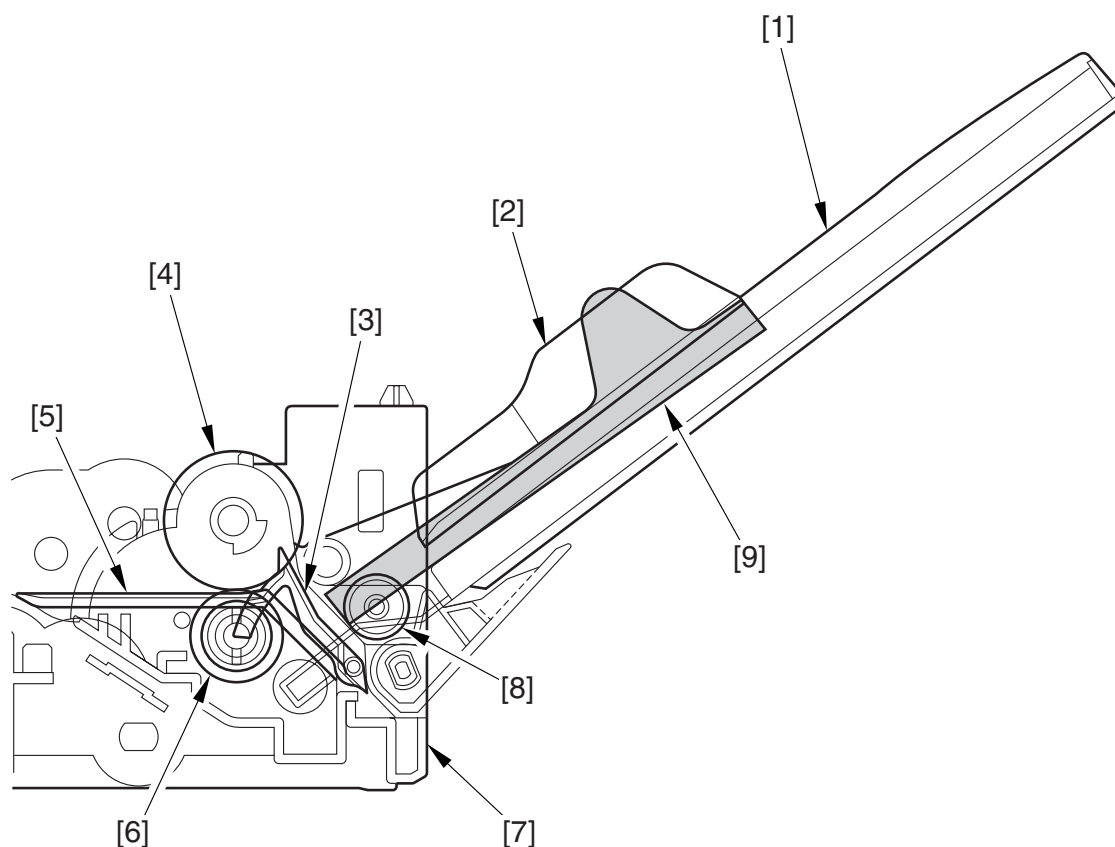

F05-401-01

- | | |
|-----------------------------------|----------------------------------|
| [1] Paper tray | [6] Separation roller (roller C) |
| [2] Side guide plate | [7] Registration multi frame |
| [3] Paper flag | [8] Last paper pick roll |
| [4] Pickup feed roller (roller D) | [9] Lifter |
| [5] Pickup guide plate | |

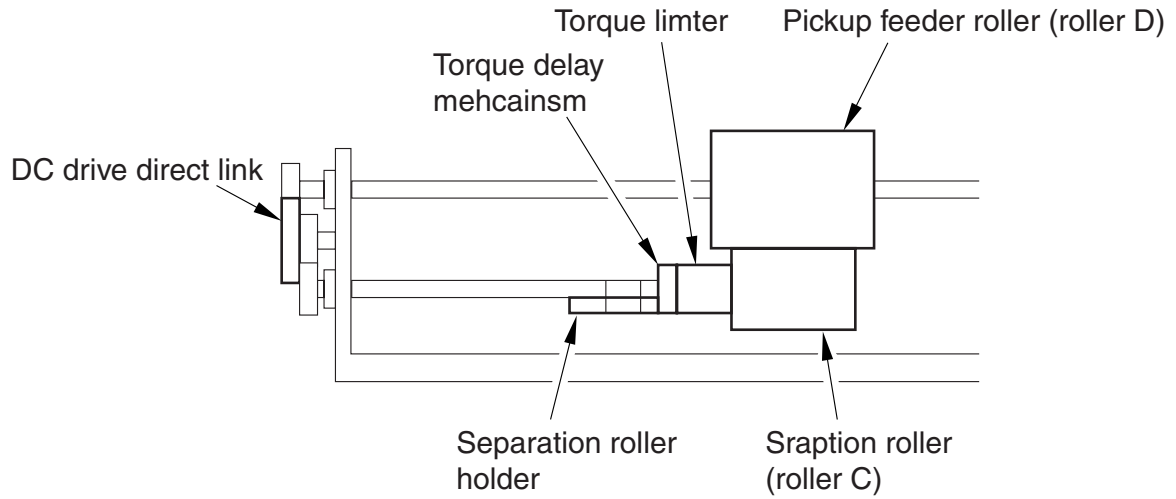

F05-401-02

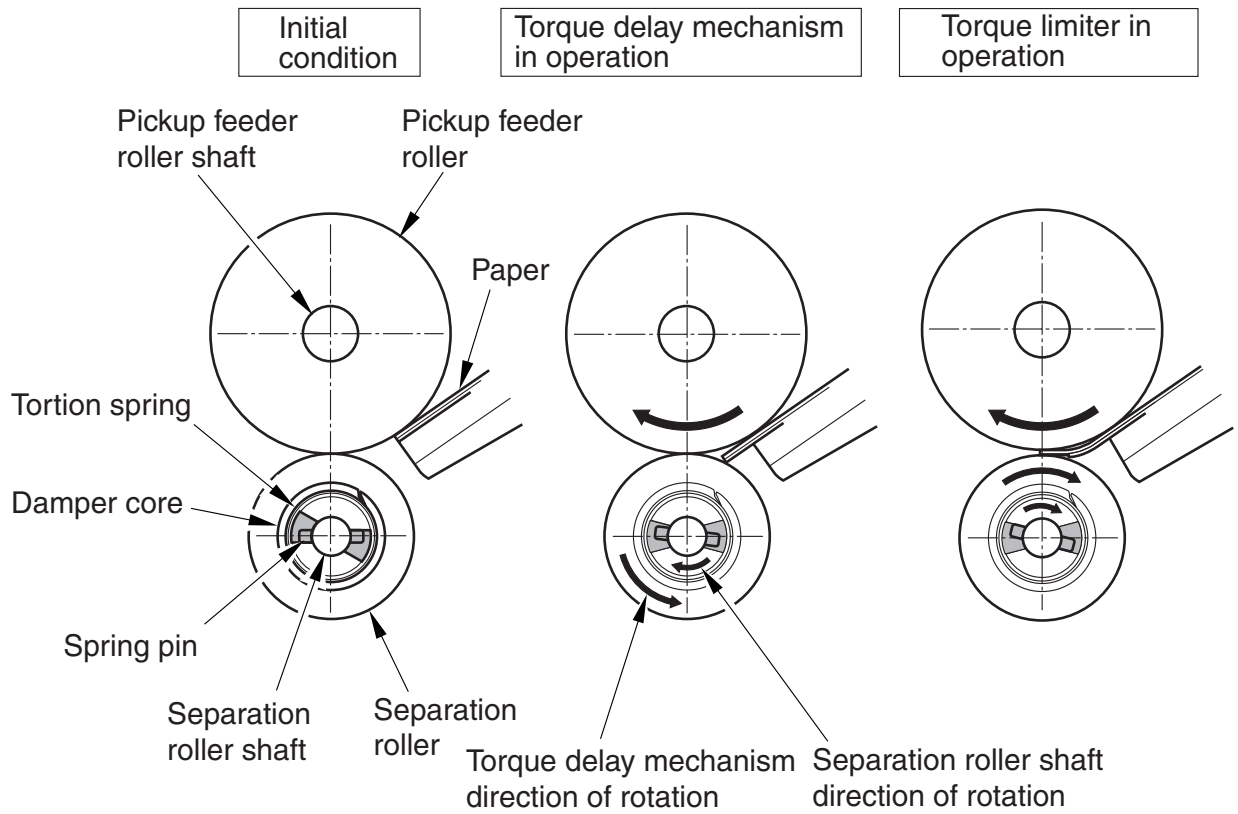

F05-401-03

4.2 Basic Sequence of Operations

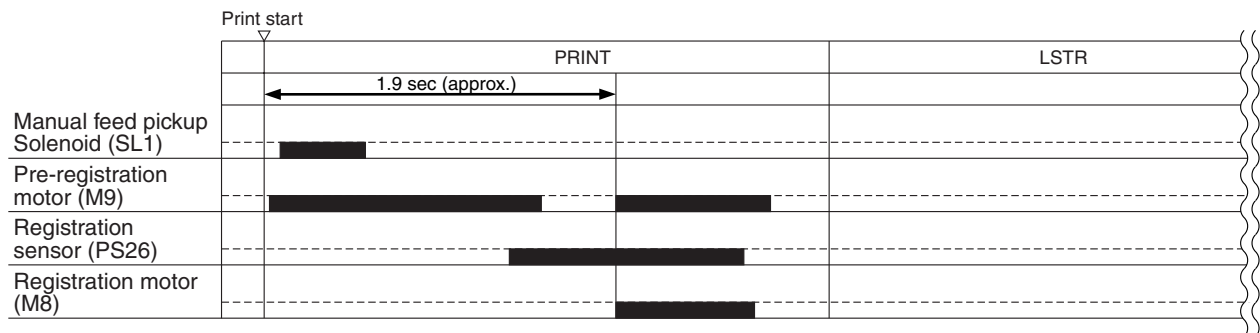

F05-402-01

4.3 Identifying the Size of Paper

The machine checks the width of paper in reference to the level of output from the variable resistor operating in conjunction with the movement of the side guide plate. The side guide plate on the manual feed tray is set by the user when he/she deposits paper.

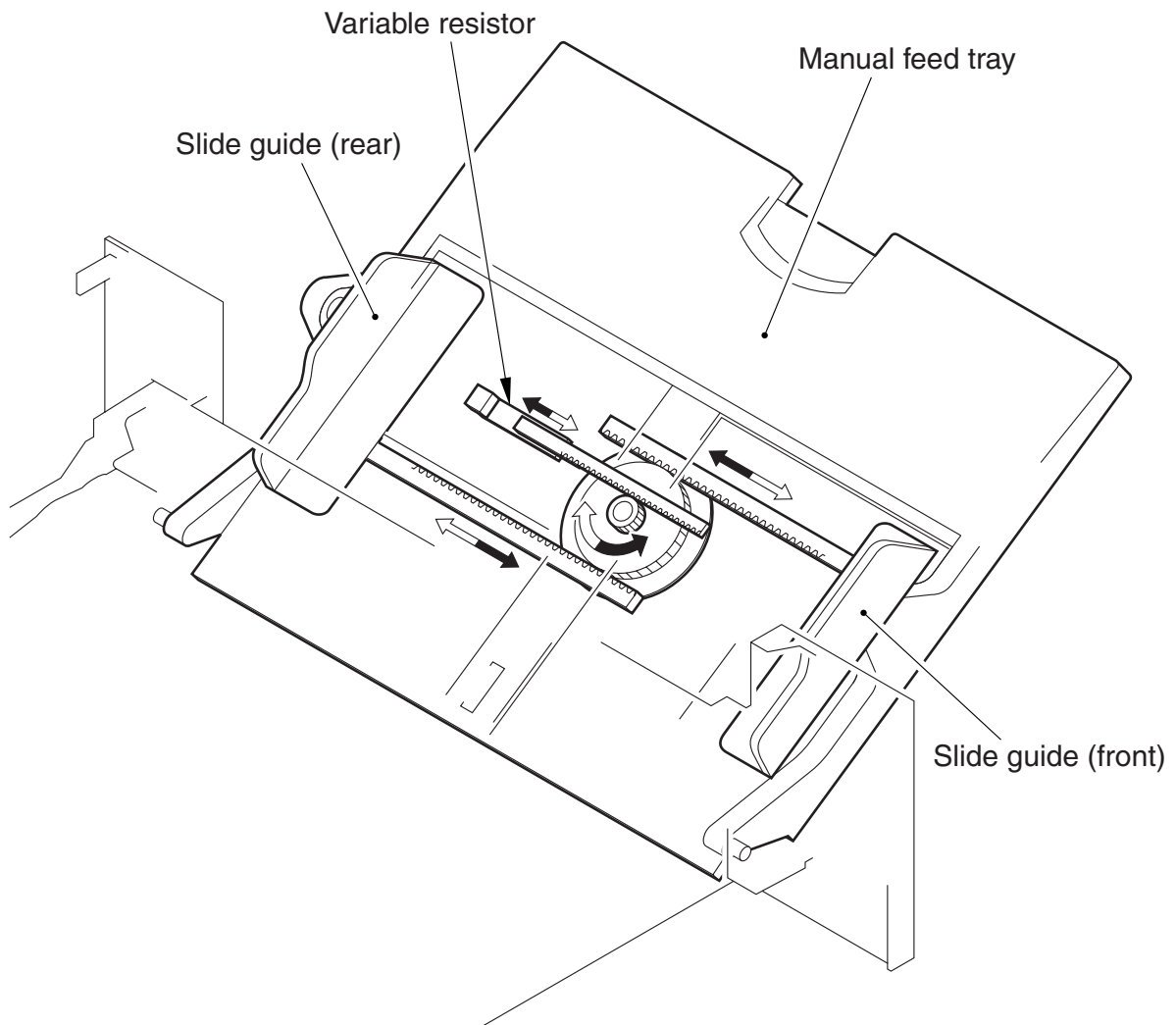

F05-403-01

4.4 Detecting the Presence/Absence of Paper

When paper is placed, the paper presses the paper detecting flag, causing the paper sensor (PS10) to go ON.

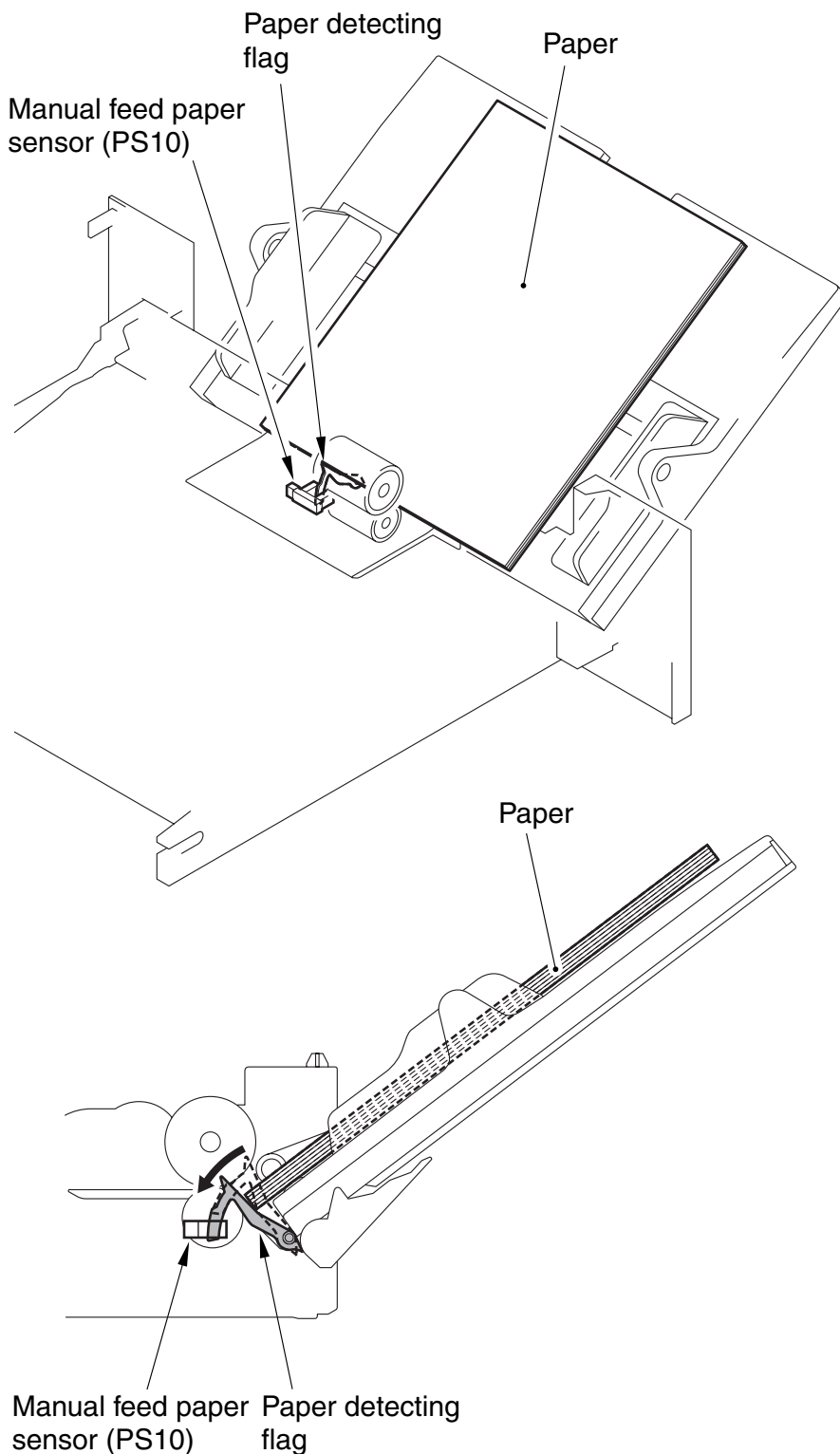

F05-404-01

4.5 Detecting the Last Paper

When the last paper pickup roll rotates, the slit in the roll causes the output of the last paper sensor (PS9) to become wave-form pulses. The last paper roll rotates only when the last paper is picked up; otherwise, it remains still. The machine will identify the paper to be the last paper if it detects 4 or more output pulses from the last paper sensor.

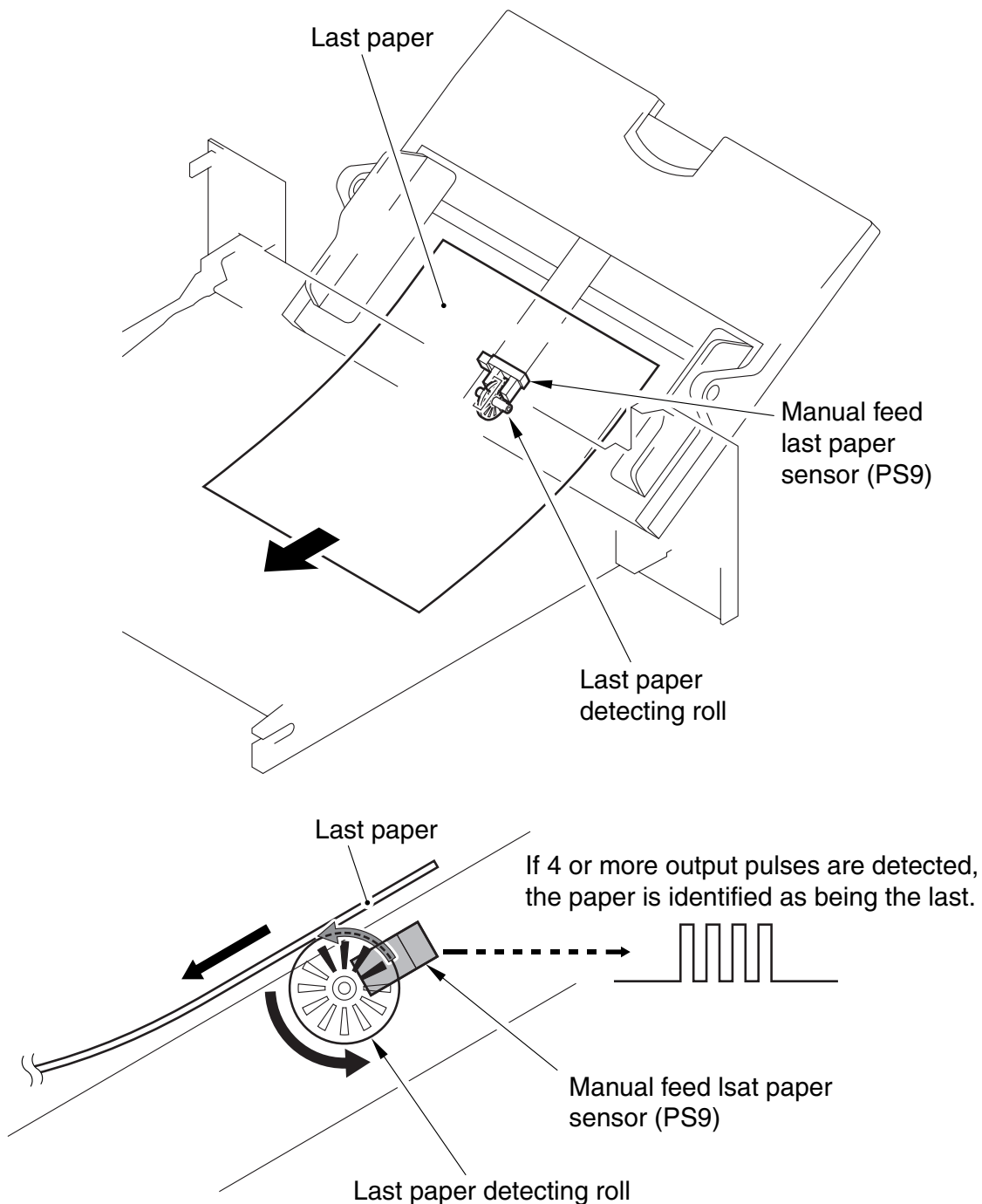

F05-405-01

5 Registration Unit

5.1 Outline

The upper registration roller and the lower registration roller are driven by the registration motor (M8), and are used to make sure that the paper and the image on the intermediate transfer belt match at a specific position. The upper guide locking arm latches in place when the unit is fitted to the machine.

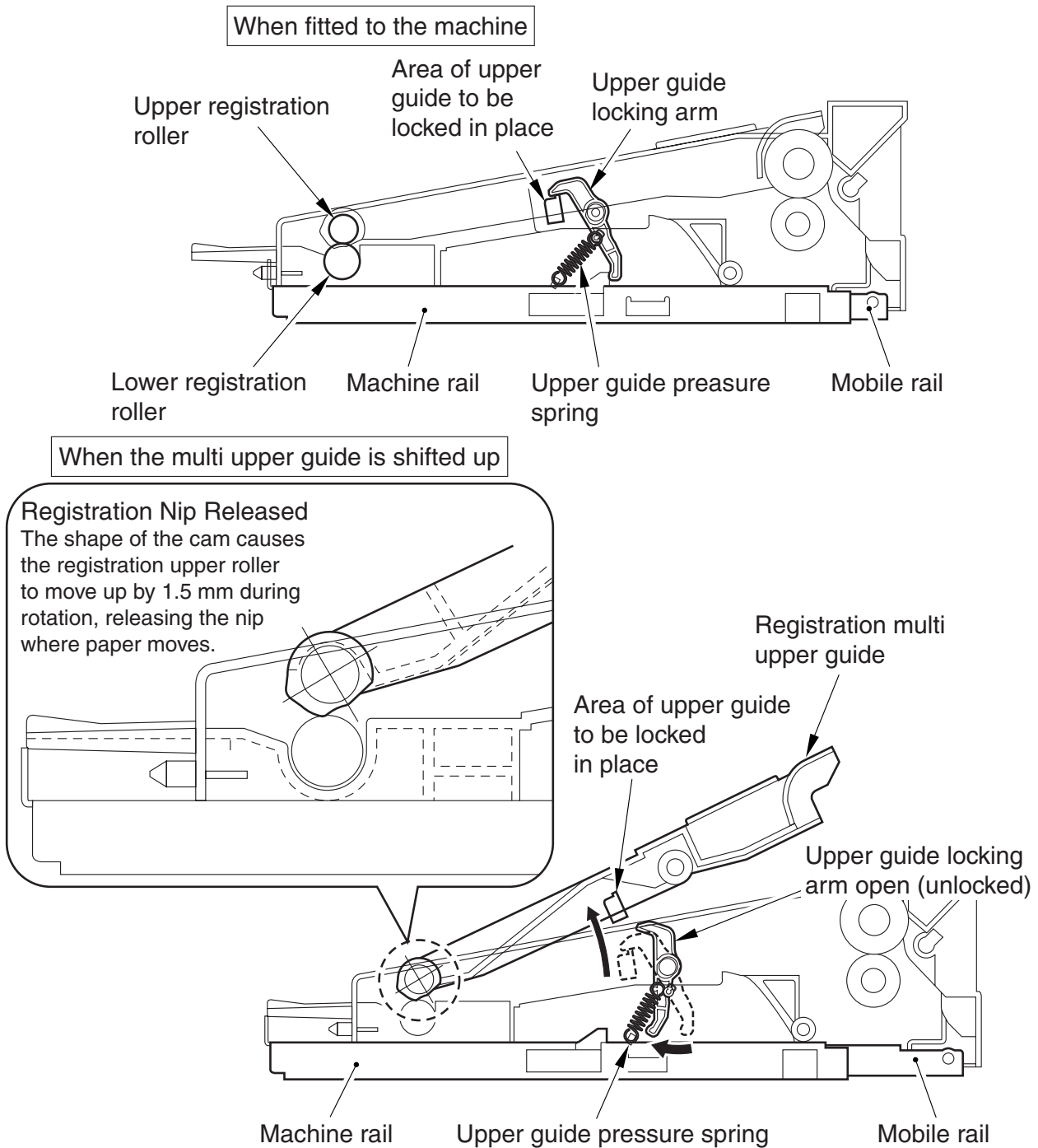

F05-501-01

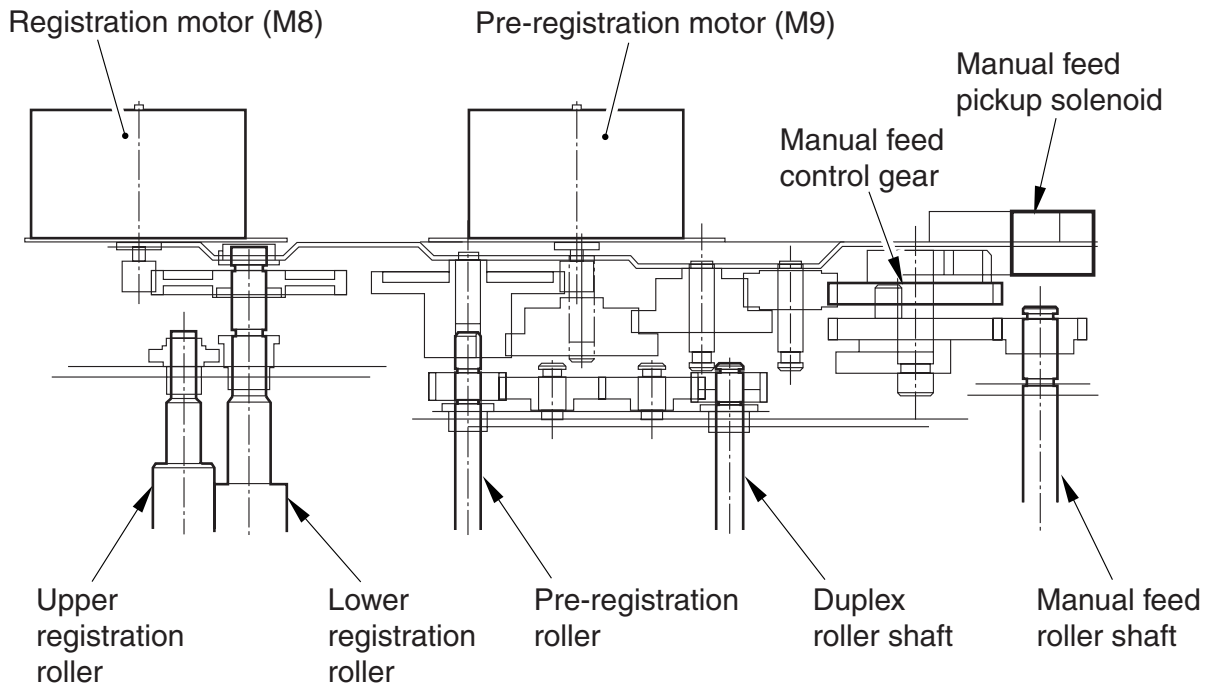

F05-501-02

6 Duplex Unit

6.1 Outline

The duplex unit is driven by the duplex motor (M26), and is used when making double-sided prints.

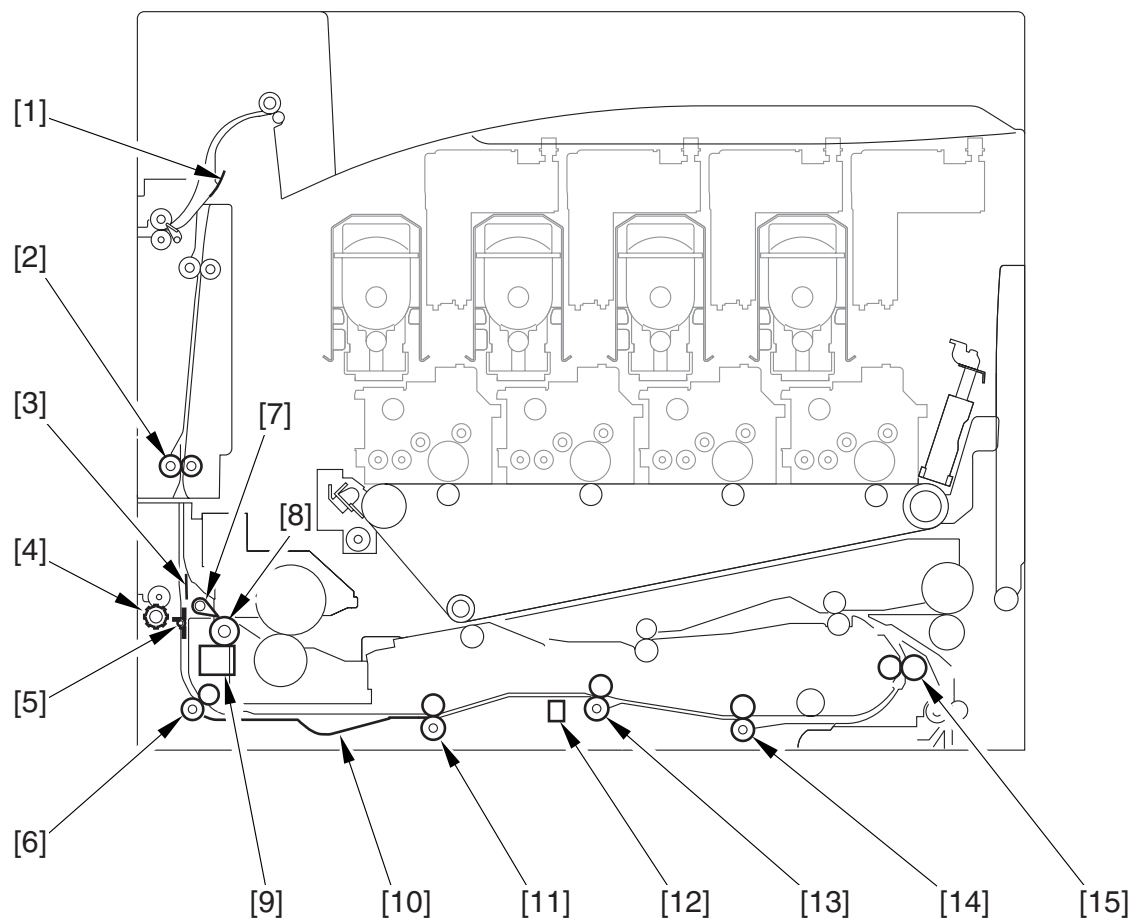

F05-601-01

- | | |
|------------------------------|---|
| [1] Reversing sheet | [9] Delivery cooling duct |
| [2] Reversing roller | [10] Arching assembly |
| [3] Reversing sheet | [11] Duplex roller 2 |
| [4] Face-up delivery roller | [12] Duplex horizontal registration sensor (PS22) |
| [5] Cross path flapper | [13] Duplex roller 3 |
| [6] Duplex roller 1 | [14] Duplex roller 4 |
| [7] FU/FD switching flapper | [15] Re-pickup roller |
| [8] Internal delivery roller | |

6.2 Controlling Horizontal Registration

The machine checks paper coming from the duplex feeder assembly in double-sided print mode for horizontal registration; it checks displacement in sub scanning direction (rear-to-front direction), and adjust the position of the laser to correct any displacement.

Detection of paper position: duplex horizontal registration sensor (PS22)

Timing of detection: starts a specific period of time after passage over the duplex registration sensor (PS21)

Drive: horizontal registration motor (M25)

Identification of position: with reference to the pulse from the horizontal registration motor

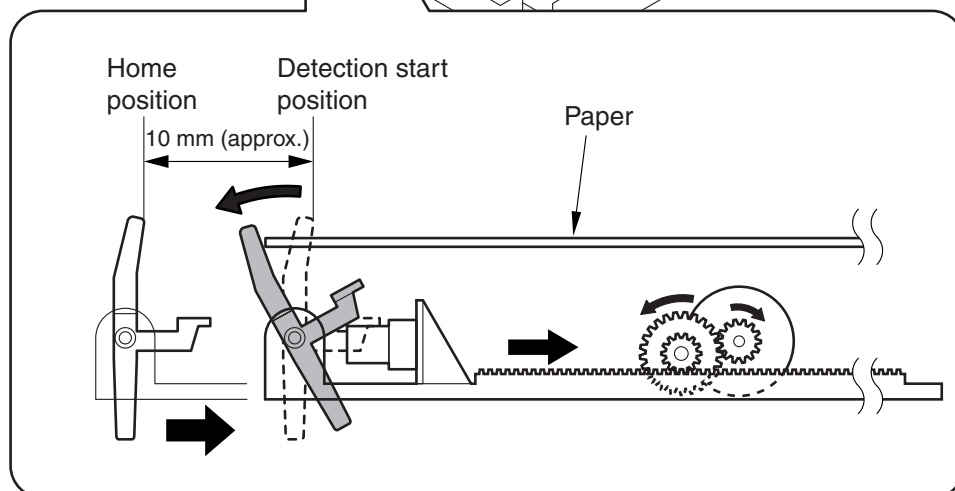
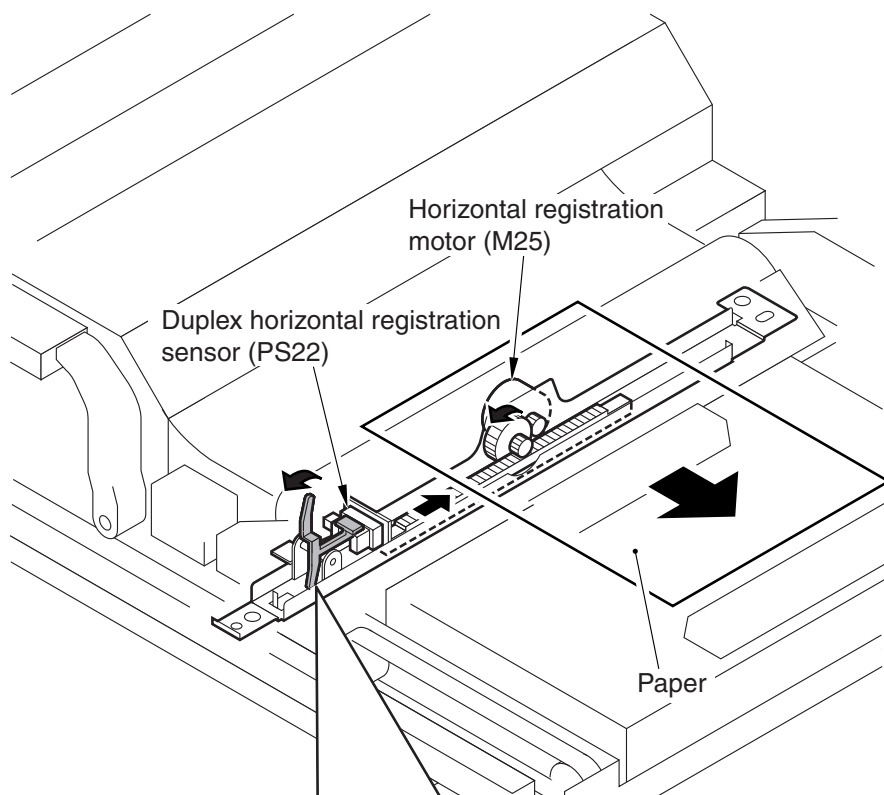

F05-602-01

6.3 Movement of Paper When Making Double-Sided Prints

6.3.1 Face-Down Delivery, A4, 5 Sheets in Circulation

The number on a white background and the number on a black background indicate the 1st side and the 2nd side, respectively.

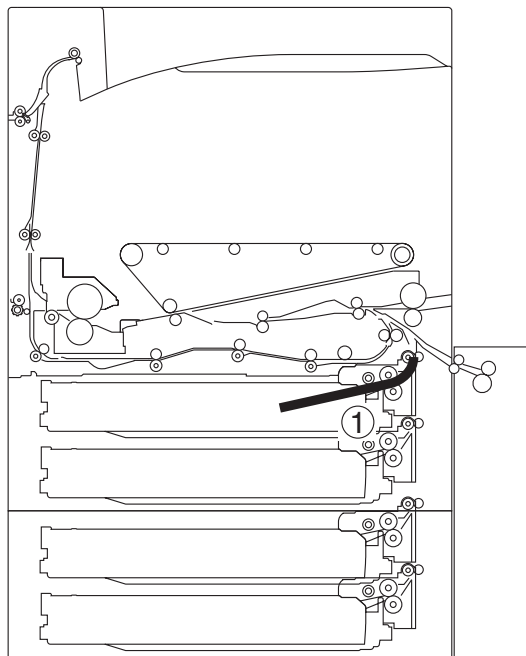

(1)

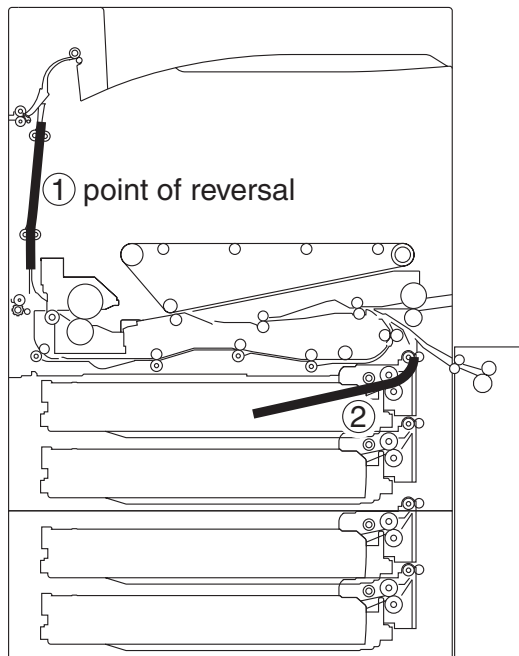

(2)

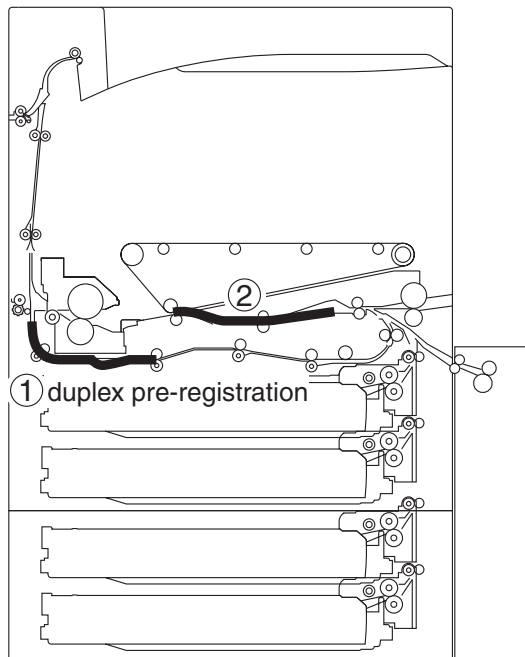

(3)

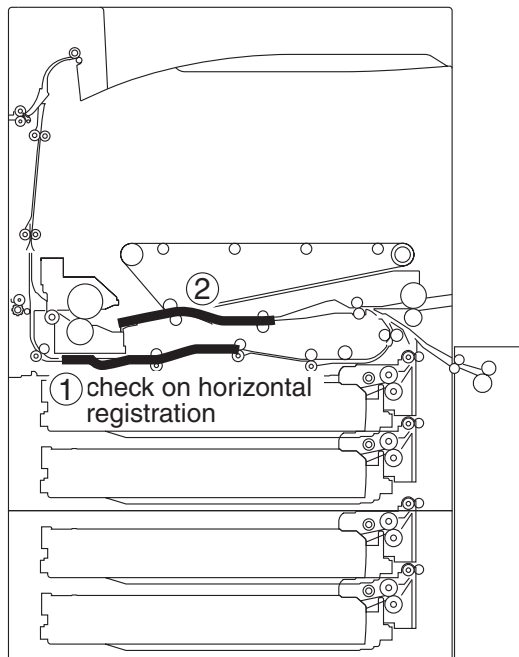

(4)

F05-603-01

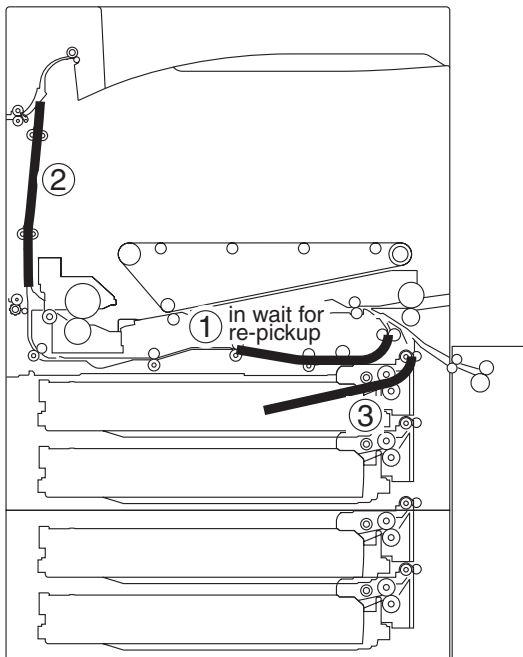

(5)

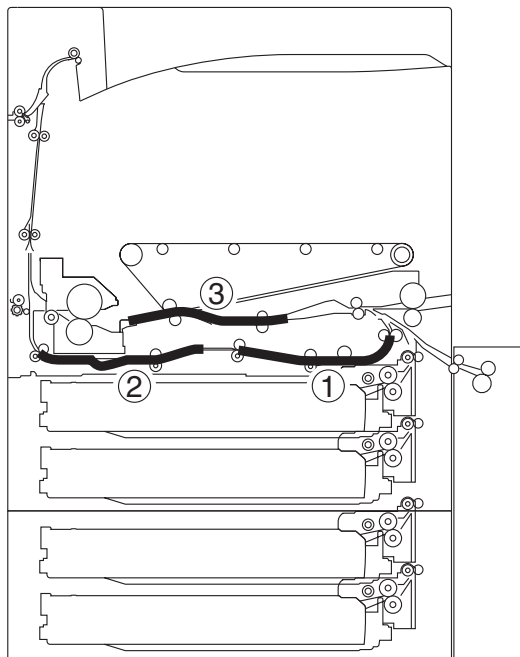

(6) with 2 sheets inside duplex unit

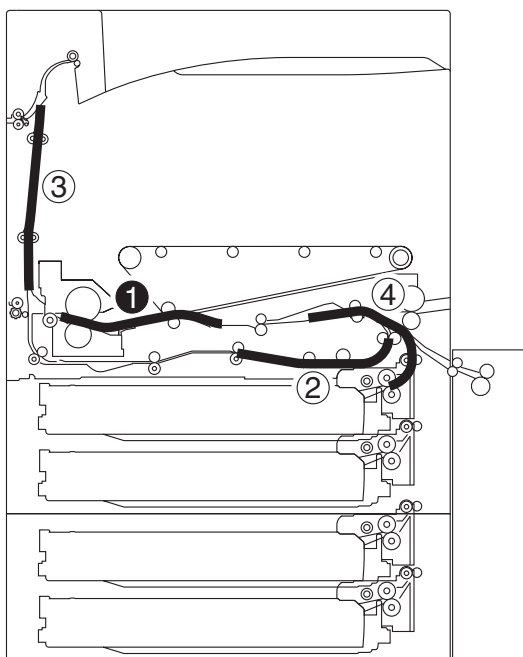

(7)

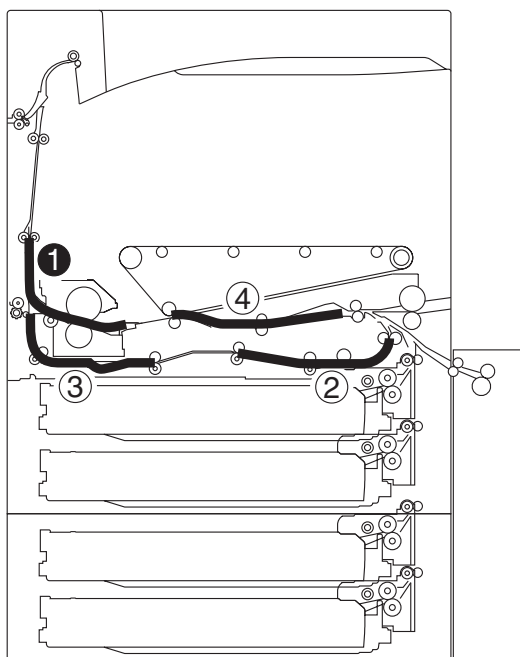

(8)

F05-603-02

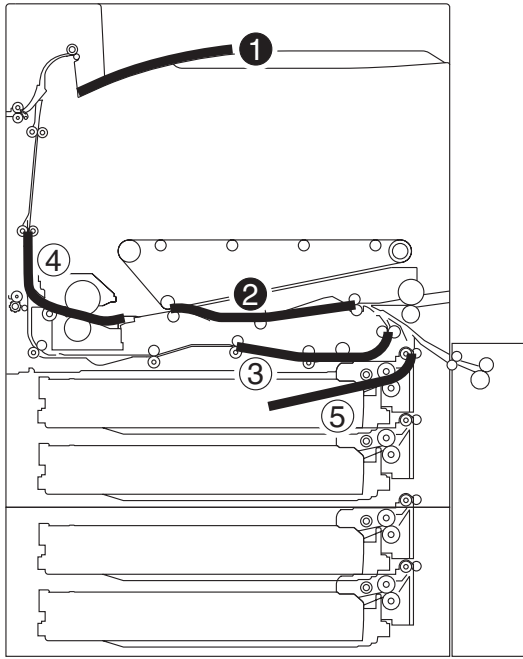

(9)

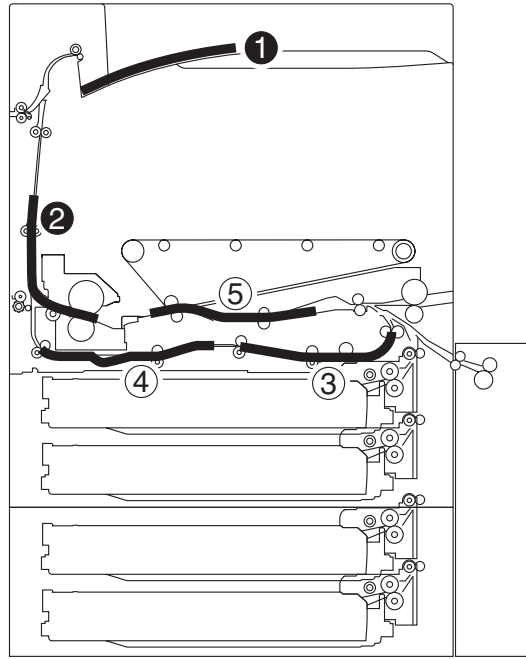

(10)

thereafter, repeats (7) through (10)

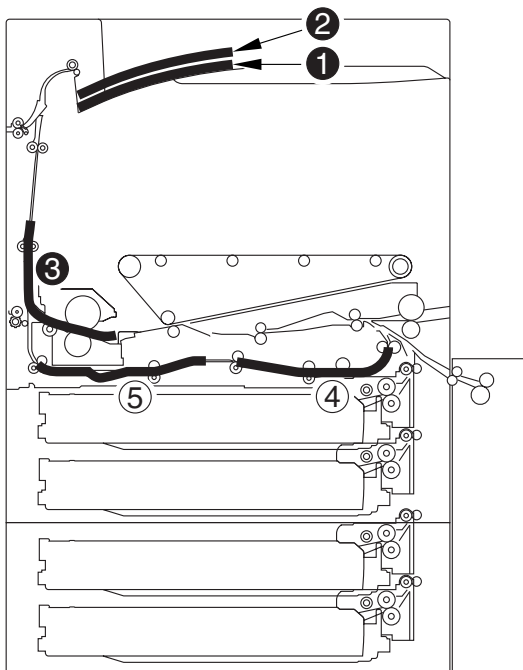

(11)

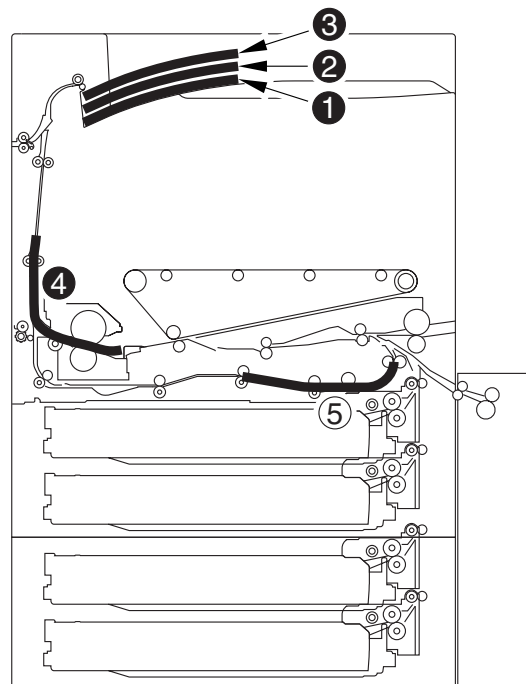

(12)

F05-603-03

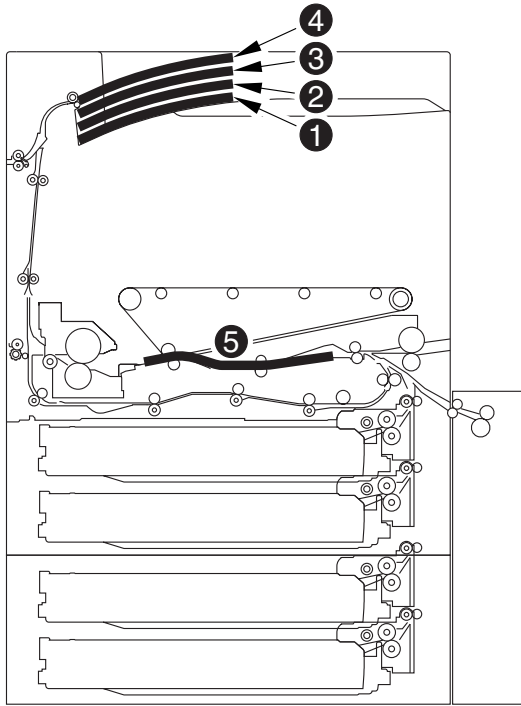

(13)

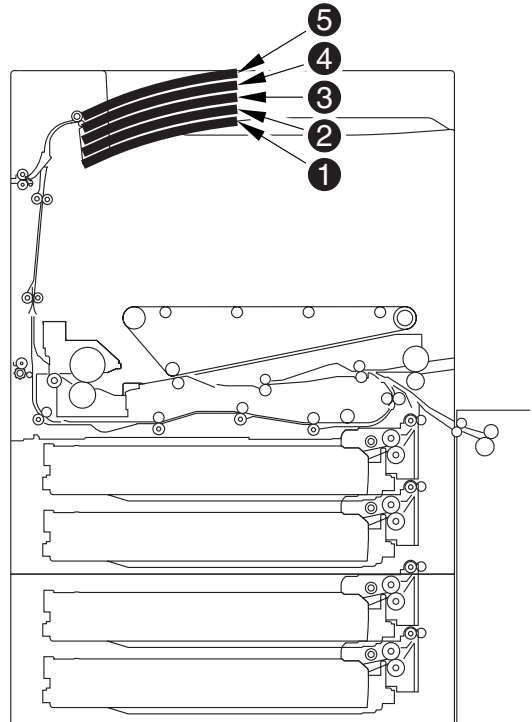

(14)

F05-603-04

6.3.2 Face-Down Delivery, A3, 3 Sheets in Circulation

The number on a white background and the number on a black background indicates the 1st side and the 2nd side, respectively.

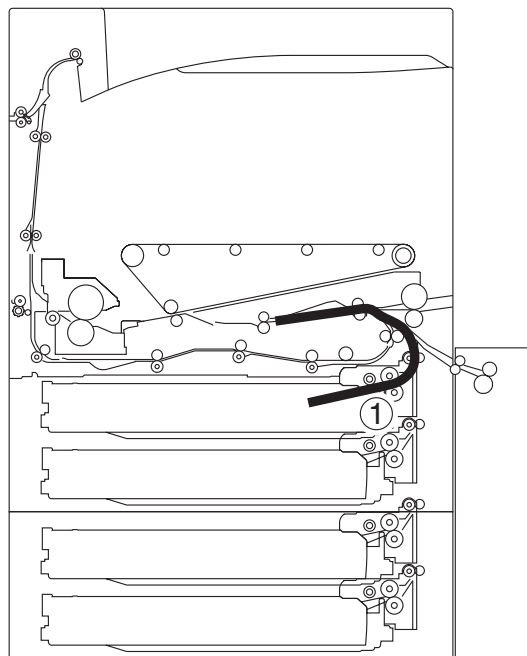

(1)

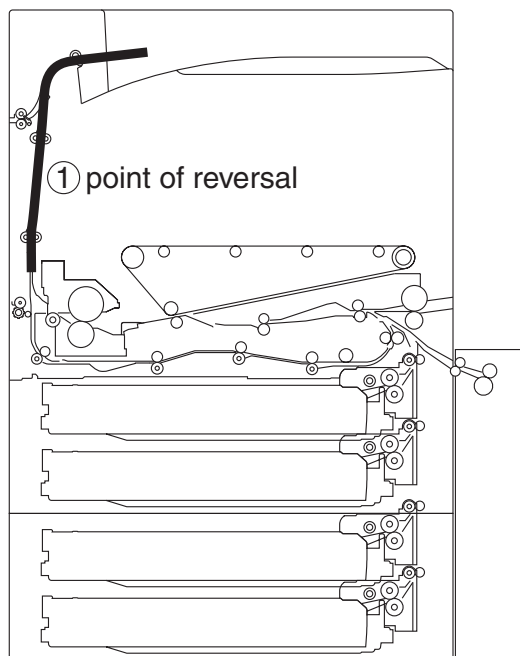

(2)

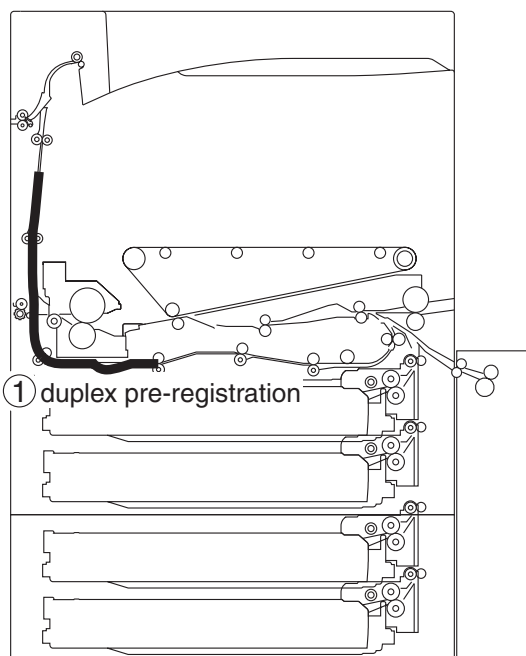

(3)

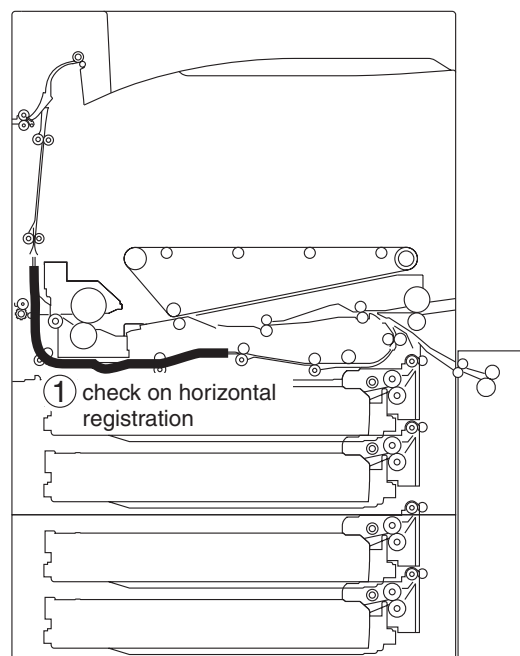

(4)

F05-603-05

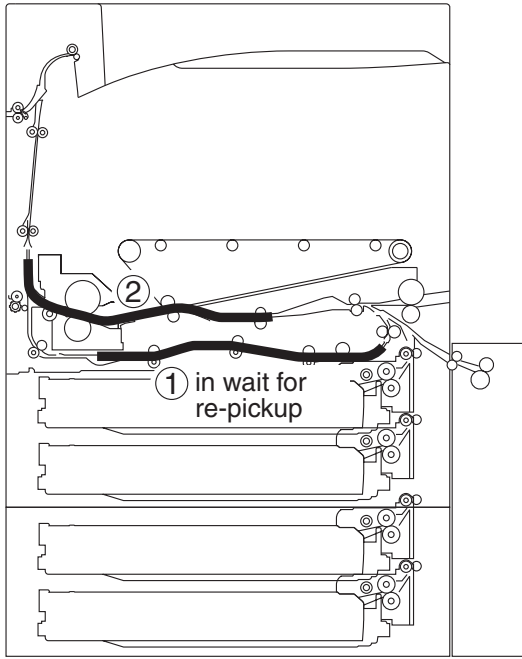

(5)

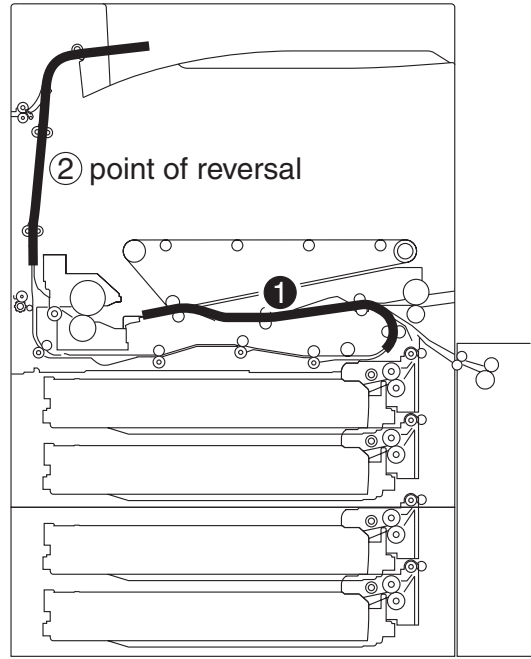

(6)

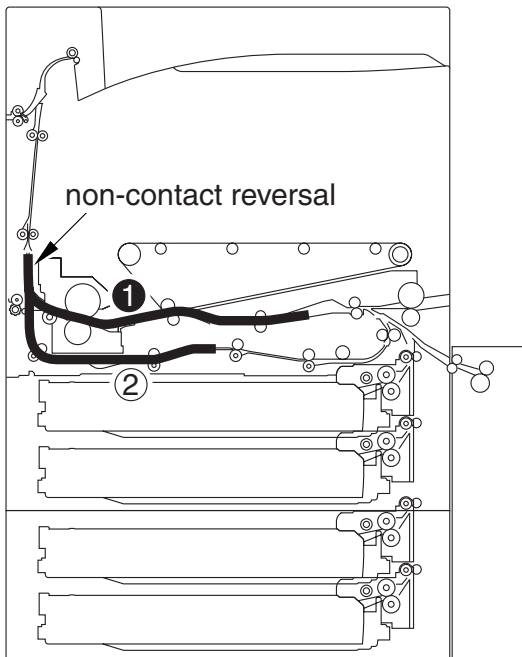

(7)

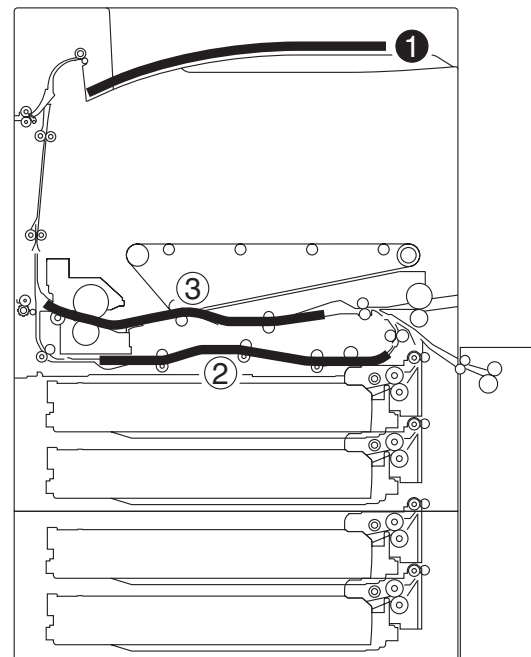

(8)

thereafter, repeats (6) through (8)

F05-603-06

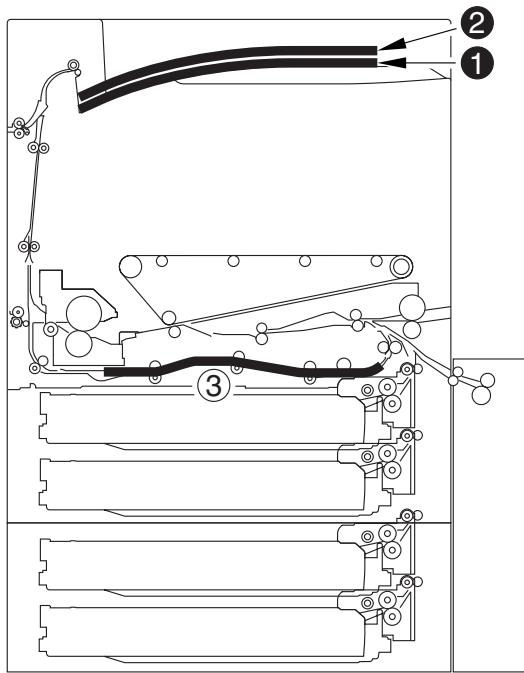

(9)

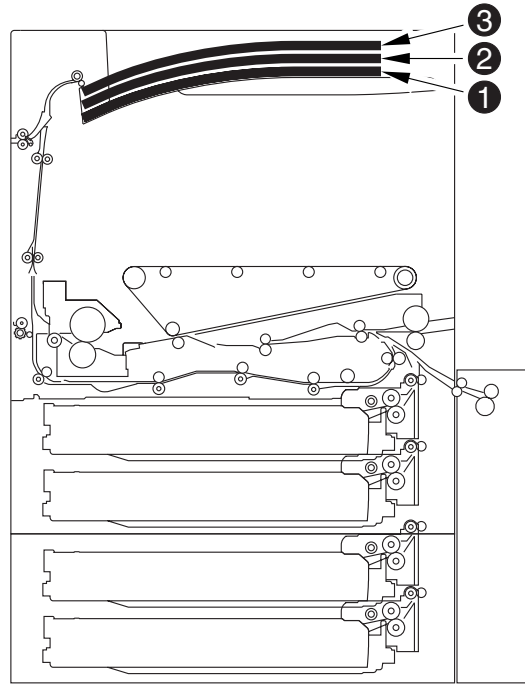

(10)

F05-603-07

7 Delivery

The machine uses any of the following 3 types of delivery (paper paths):

face-down delivery (center delivery tray)

face-down delivery (copy tray)

face-up delivery (side delivery tray)

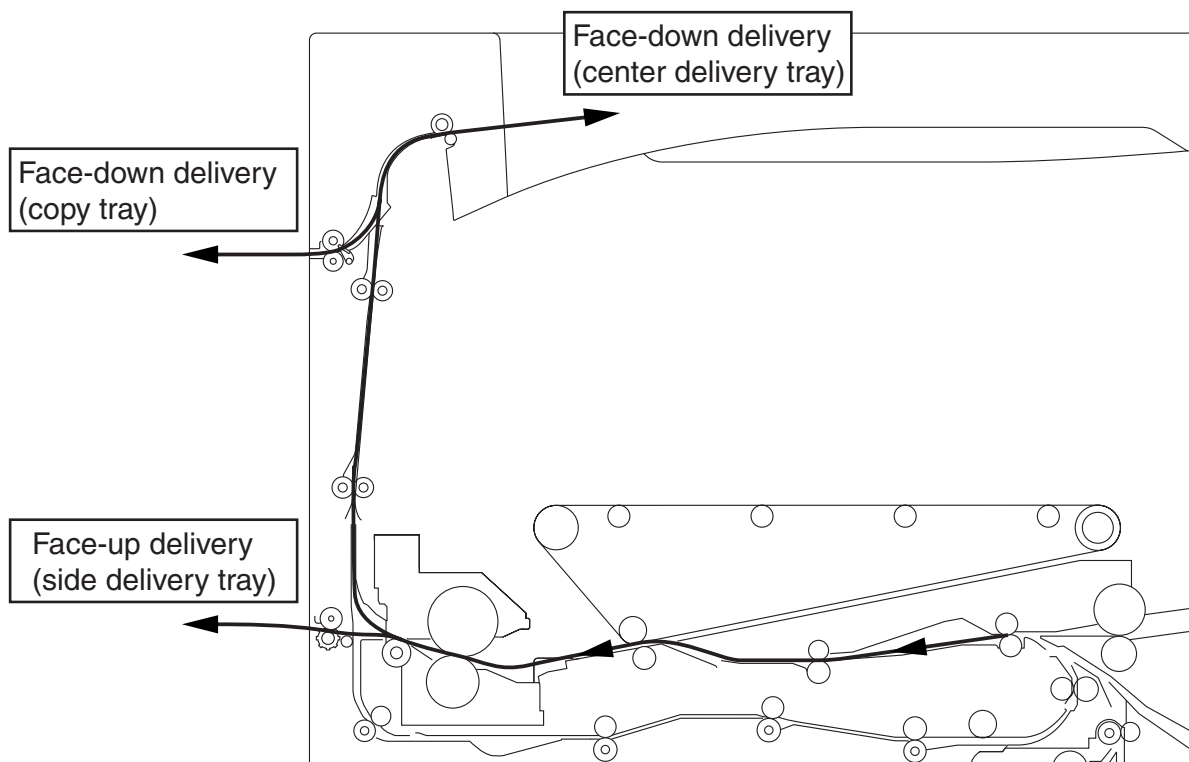

F05-700-01

7.1 Switching Between Face-Up and Face-Down (using the FU/FD switching flapper)

7.1.1 Movement in the Direction of Face-Down Delivery

After moving through the fixing unit, the paper moves along the FU/FD switching flapper now facing downward; it then pushes down the plastic sheet to move to the vertical path direction for face-down delivery.

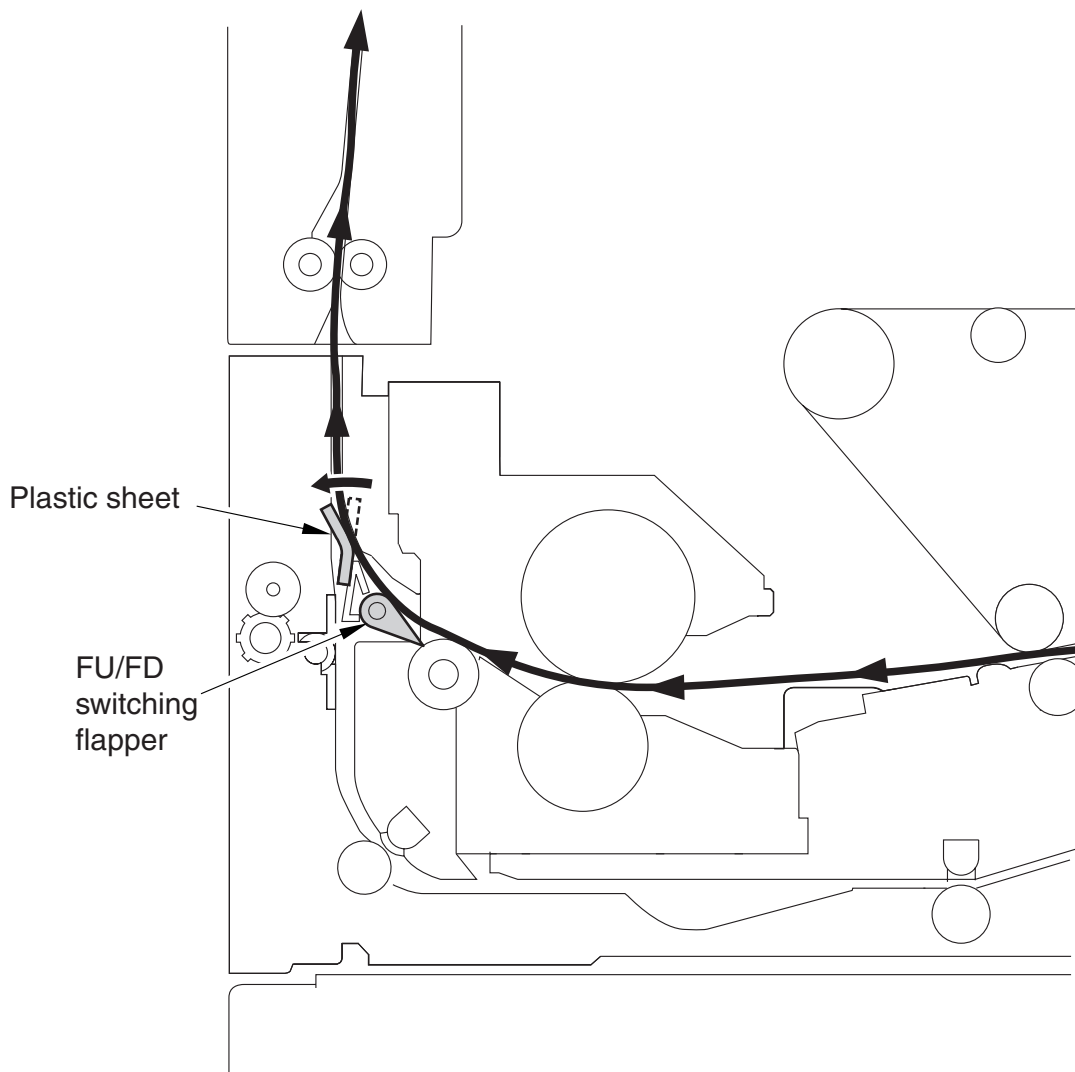

F05-701-01

7.1.2 Movement in the Direction of Face-Up Delivery

After moving through the fixing unit, the paper moves under the FU/FD switching flapper, which has been shifted up by the delivery path switching solenoid (SL2); at this time the cross path flapper is also switched over by the work of the delivery path switching solenoid 2 (SL5), thus guiding the paper into the direction of face-up delivery.

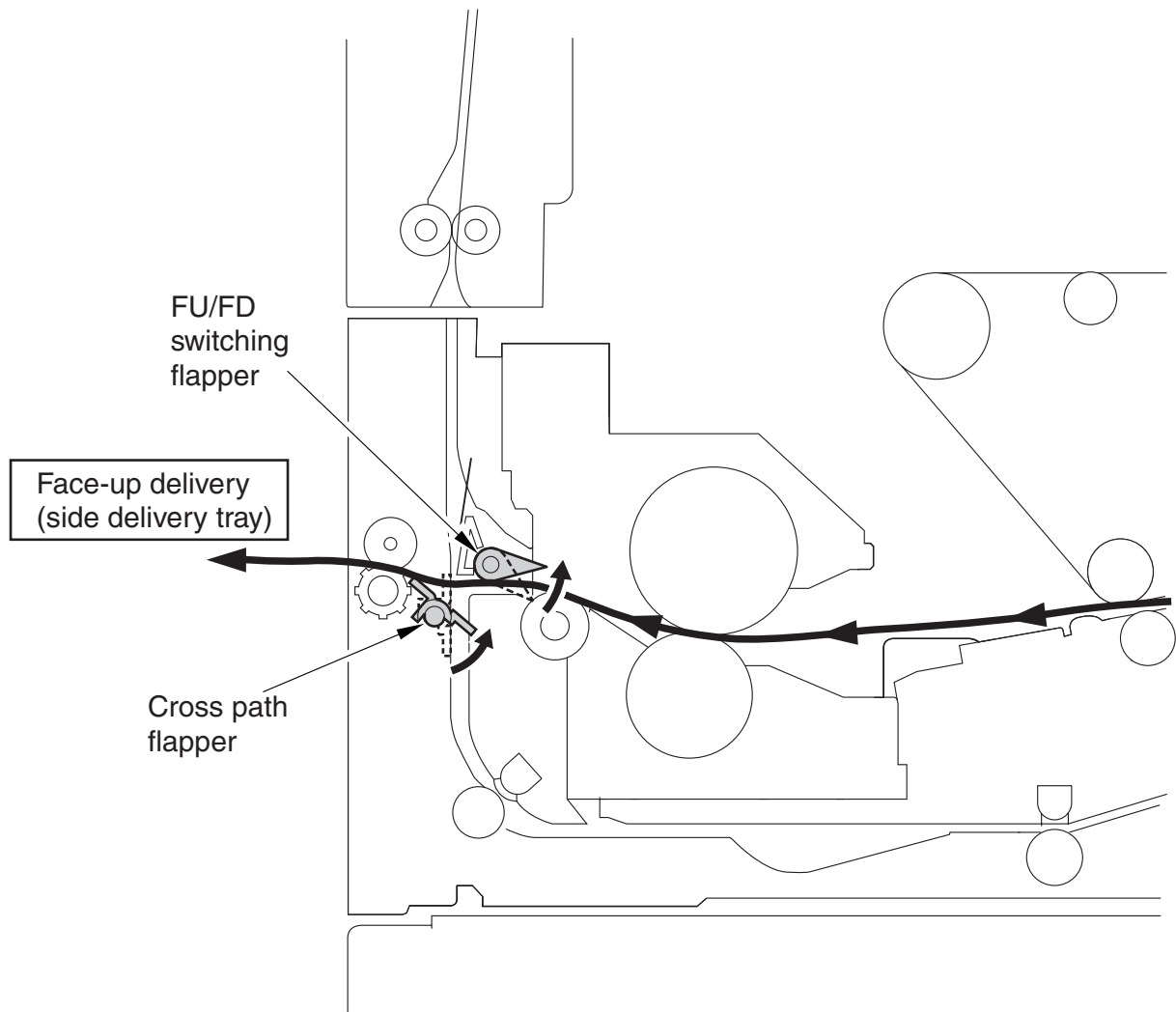

F05-701-02

7.2 Switching Between Face-Down Center Tray Delivery and Copy Tray Delivery

7.2.1 Movement for Center Tray Delivery

The paper moves while pushing down the plastic sheet, and then moves ahead for center tray delivery.

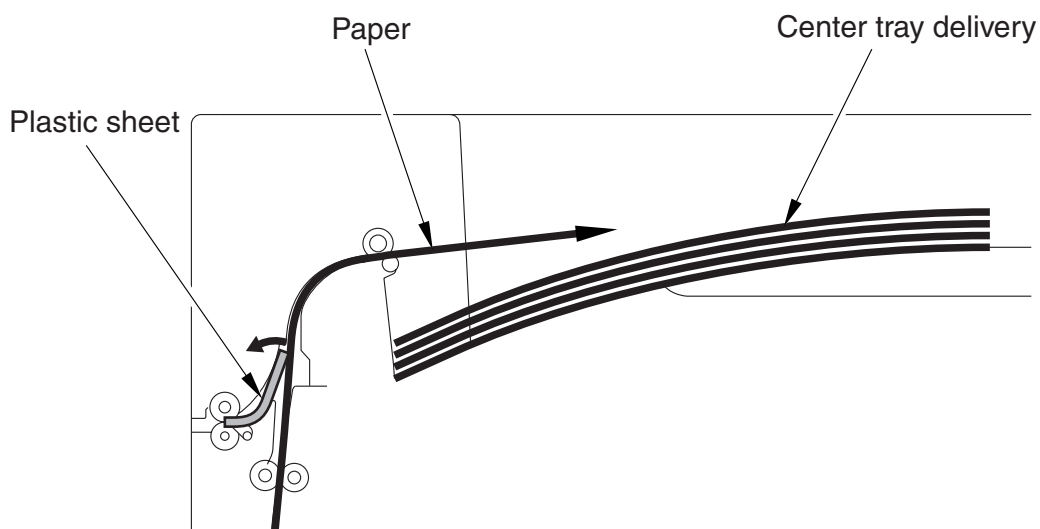

F05-702-01

7.2.2 Movement for Copy Tray Delivery

The paper moves while pushing down the plastic sheet, and then moves ahead in the direction of the center tray. Immediately after the trailing edge of the paper moves past the plastic film the movement stops, at which time the movement reverses so that the paper moves along the plastic sheet in the direction of the copy tray.

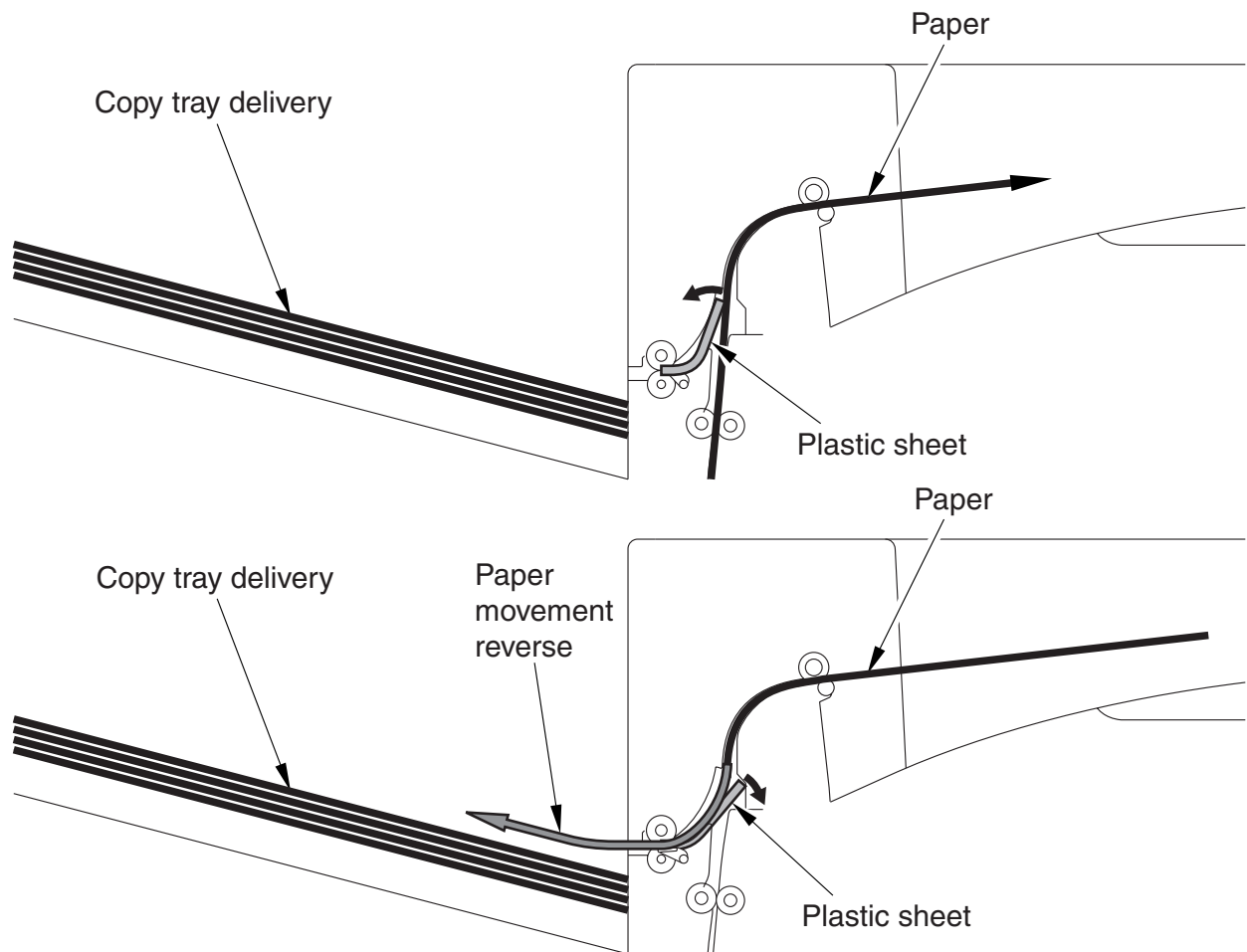

F05-702-02

8 Disassembly and Assembly

8.1 Removing the Pickup Unit



Both pickup units 1 and 2 may be removed in the same way.

- 1) Slide out the cassette.
- 2) Slide out the manual feed unit, and open the pickup vertical path cover.
- 3) Remove the 2 screws [1], and detach the machine's front right cover [2].

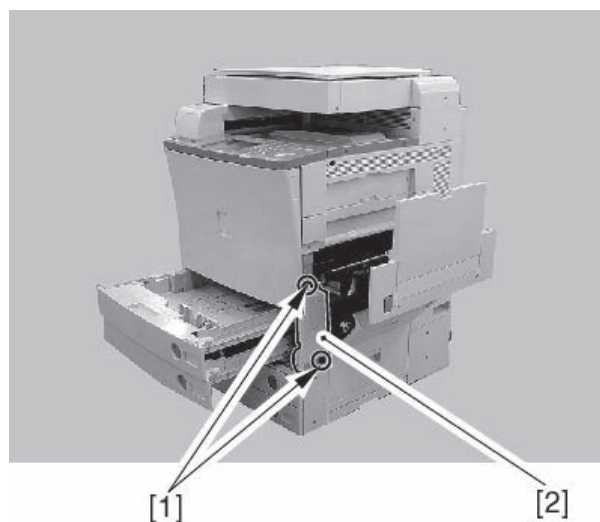

F05-801-01

4)



The rear right cover is fitted with the rear lower cover; shift it to the direction indicated to detach.

Remove the 2 screws [1], and detach the rear right cover [2].

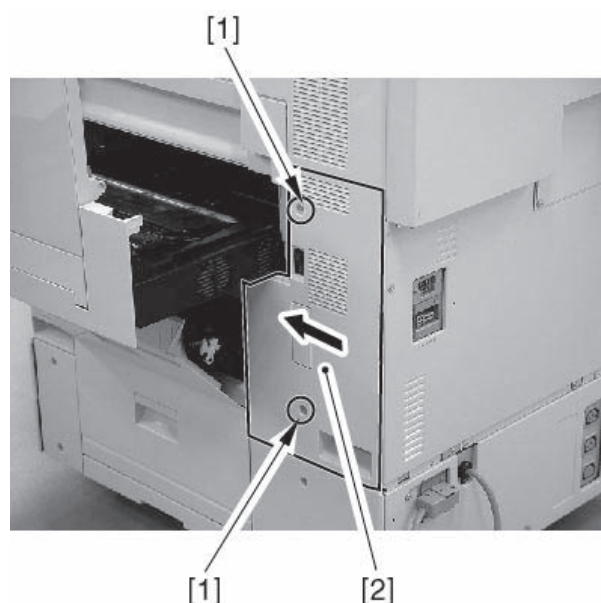

F05-801-02

- 5) Remove the screw [2] to detach the pickup vertical path lower cover [1]; then, detach the pickup vertical path cover [3].

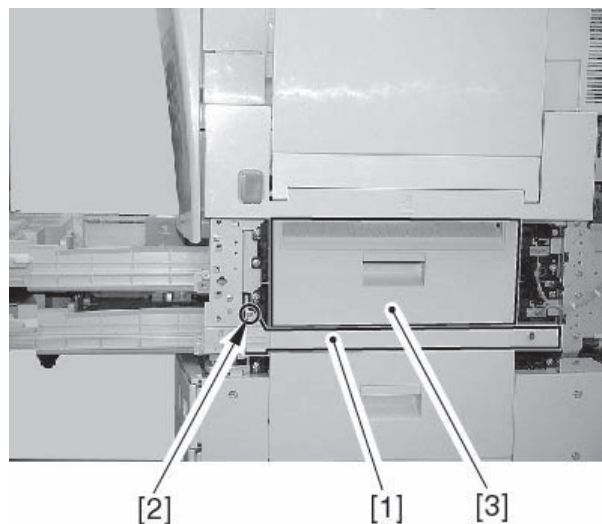

F05-801-03

- 6) Disconnect the connector [1], and remove the 4 screws [2]; then, detach the pickup unit [3].

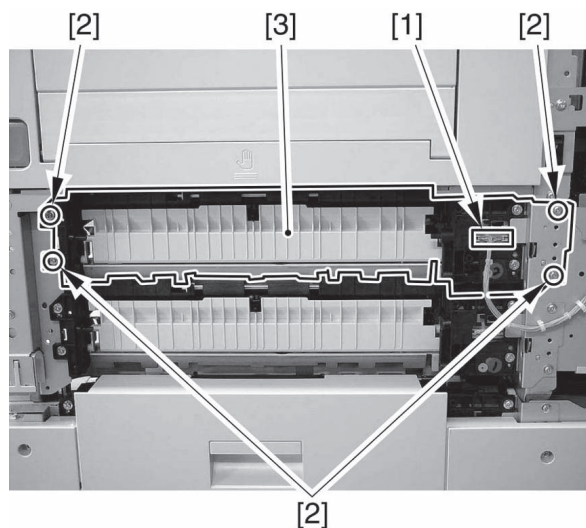

F05-801-04

8.2 Removing the Pickup Roller



The pickup roller may be removed in the same way for both cassette holders 1 and 2.

- 1) Slide out the cassette.
- 2) Put your hand through the machine's front; then, pick the tab [A] of the pickup roller [1], and pull it out.

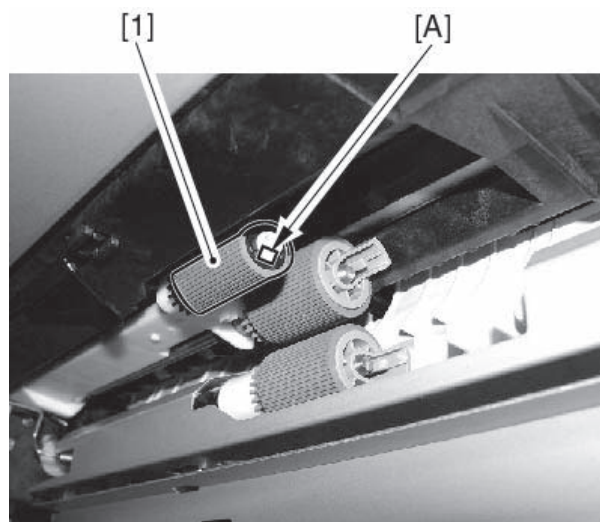

F05-802-01

8.3 Removing the Feed Roller



The feed roller may be removed in the same way for both cassette holders 1 and 2.

- 1) Slide out the cassette.
- 2) Put your hand through the machine's front; then, pick the tab [A] of the feed roller, and pull it out.

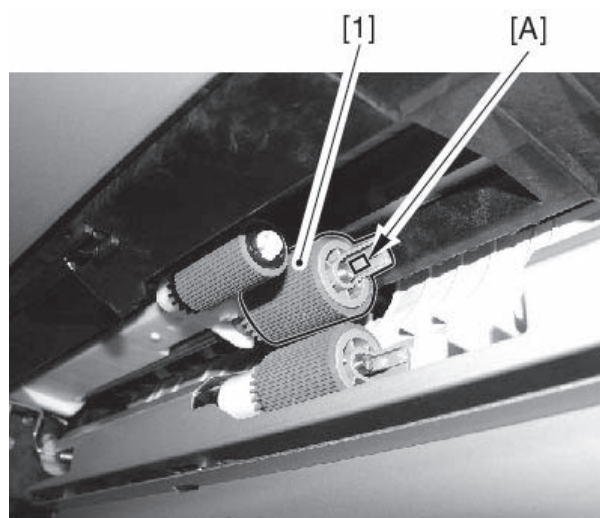

F05-803-01

8.4 Removing the Separation Roller



The separation roller may be removed in the same way for both cassette holders 1 and 2.

- 1) Slide out the cassette.
- 2) Put your hand through the front of the machine; then, pick the tab [A] of the separation roller [1], and pull it out.

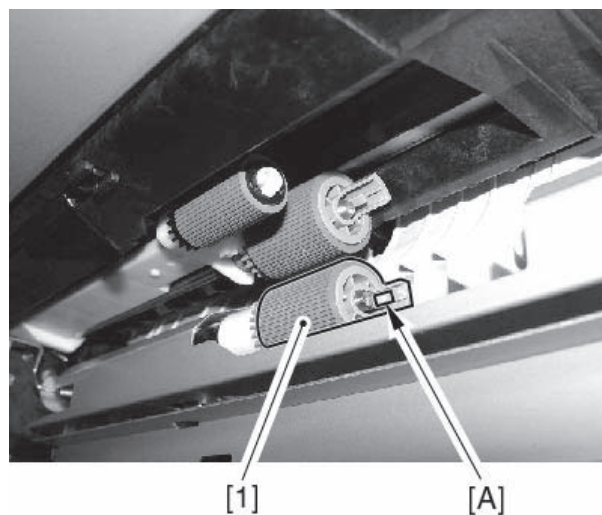

F05-804-01

8.5 Removing the Vertical Path Roller

- 1) Remove the pickup unit. (See 8.1 ‘Removing the Pickup Unit.’)
- 2) Remove the 2 screws [1] at the rear, and remove the bracket [2].

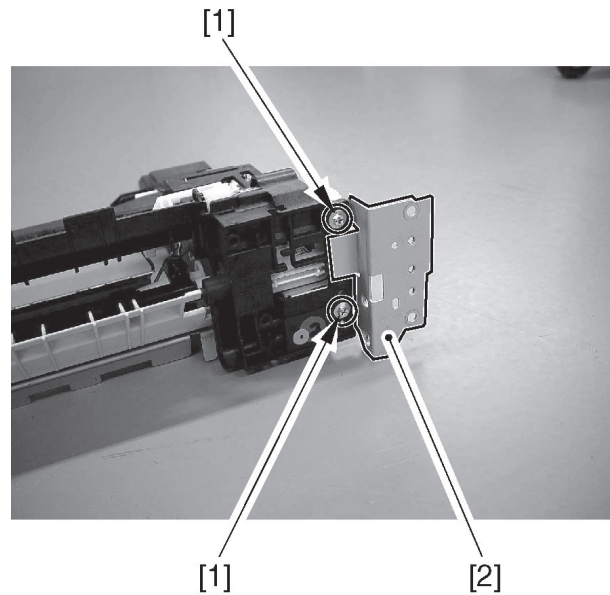

F05-805-01

- 3) Disconnect the connector [1], and remove the screw [1]; then, detach the cassette pickup solenoid [3]. Thereafter, remove the 5 screws [4], and detach the sensor mounting plate [5].

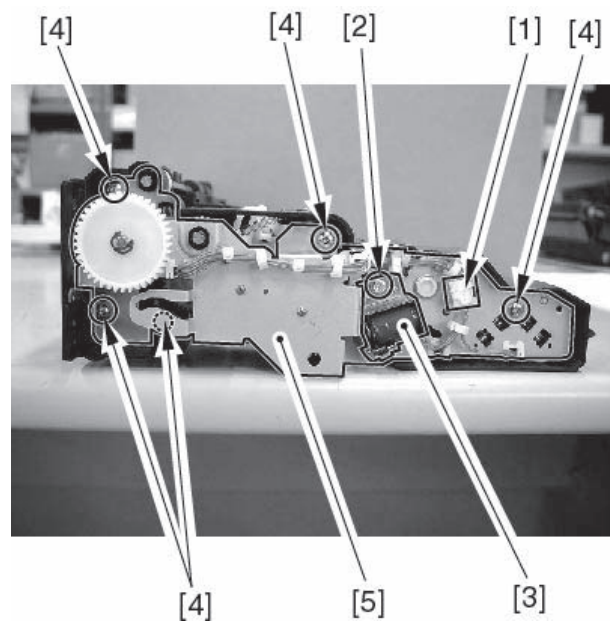

F05-805-02



When attaching the sensor mounting plate, see 8.6 ‘Mounting the Sensor Mounting Plate.’

- 4) Free the claw [A] of the gear [1] at the rear, and detach the gear and the bushing [2].

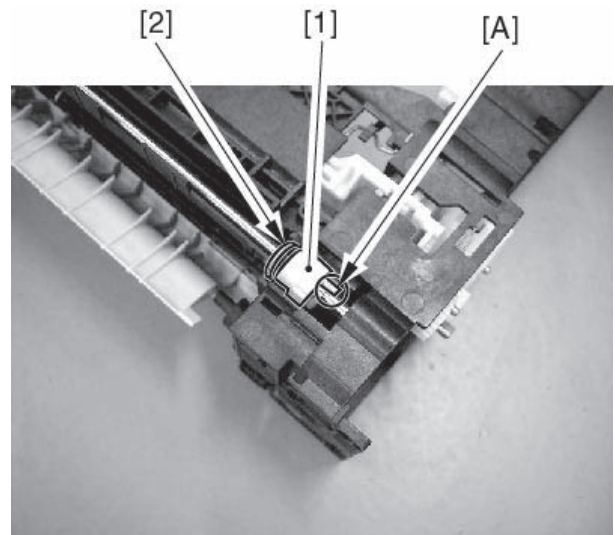

F05-805-03

- 5) Free the claw [A] of the bushing [1] at the front; shift the vertical path roller [2] to the rear and then pull it upward to detach.

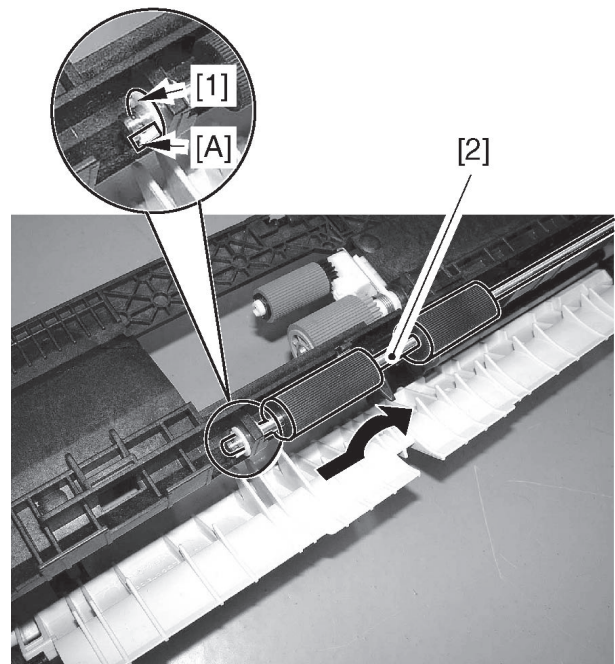

F05-805-04

8.6 Mounting the Sensor Mounting Plate



Any of the gears can drop off. When attaching the sensor mounting plate, be sure that the pickup unit will not face downward.

- 1) Attach the bushing [1] to the frame; then, attach the gear shaft [2].

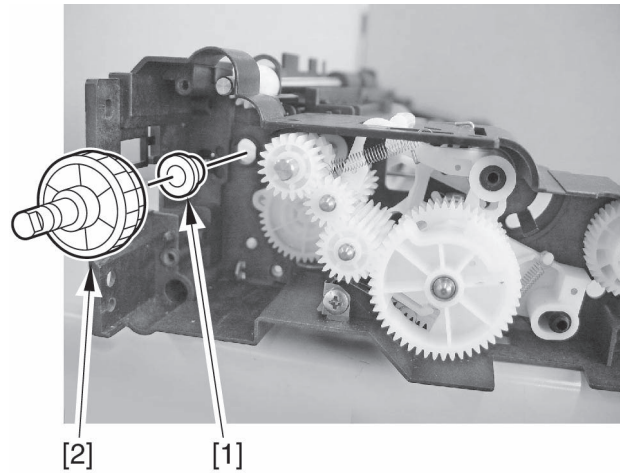

F05-806-01

- 2) Fit the 6 locations [A] indicated in the figure firmly into the holes of the mounting plate; then, secure the sensor mounting plate [2] in place.

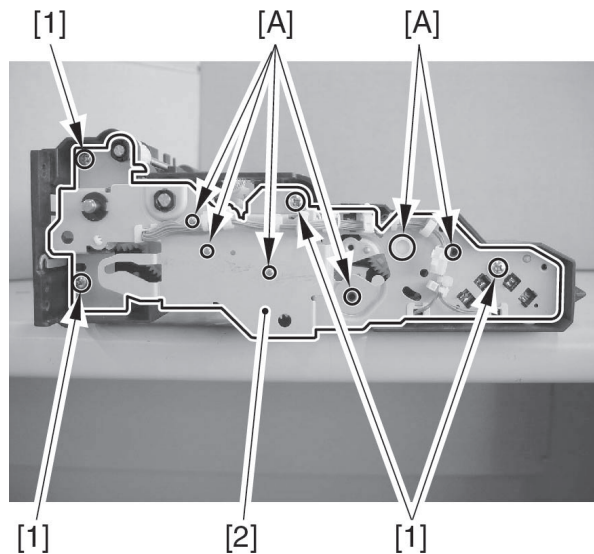

F05-806-02

- 3) Attach the gear [1] and the E-ring [2].

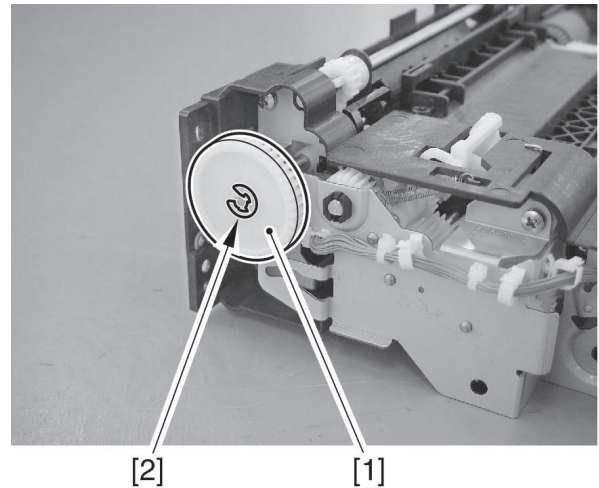

F05-806-03



Be sure not to leave the pickup solenoid [1] behind. When mounting it, be sure that the stop segment [2] is fitted firmly with the cam gear [3].

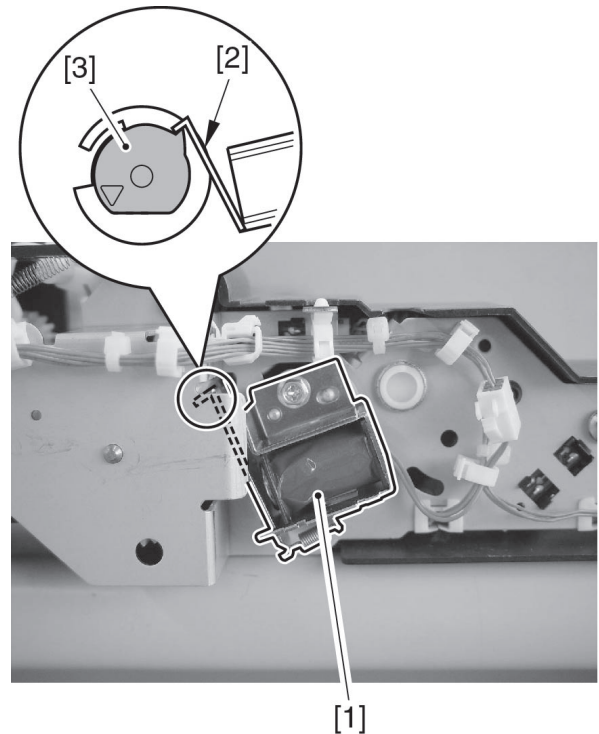

F05-806-04

- 4) Turn the gears to see that the movement is smooth.

8.7 Removing the Pickup Vertical Path Cover Open/Closed Sensor

- 1) Remove the pickup unit 1. (See 8.1 'Removing the Pickup Unit.')
- 2) Disconnect the connector [1], and remove the screw [2]; then, detach the sensor mounting plate [3].

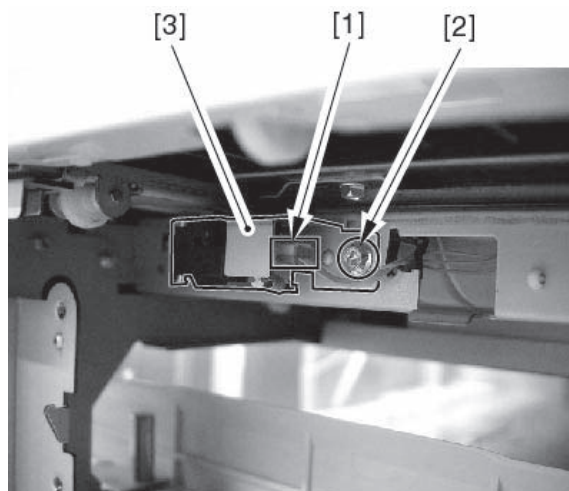

F05-807-01

- 3) Remove the spring [1], and detach the sensor flag [2].

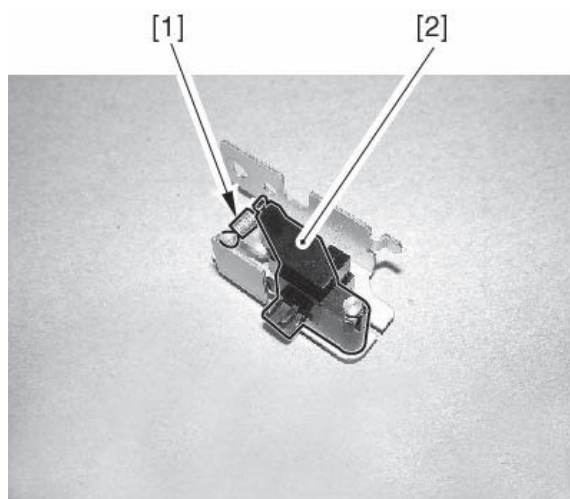

F05-807-02

- 4) Remove the pickup vertical path cover open/closed sensor [1].

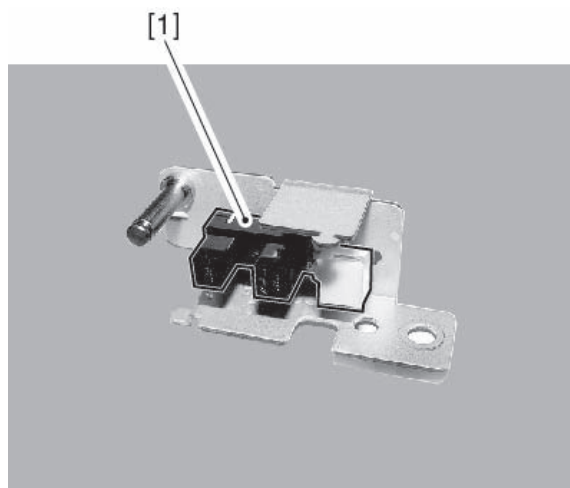

F05-807-03

8.8 Removing the Cassette Retry Paper Sensor

- 1) Remove the pickup unit. (See 8.1 ‘Removing the Pickup Unit.’)
- 2) Remove the sensor mounting plate. (See 8.5 ‘Removing the Vertical Path Roller.’)



When attaching the sensor mounting plate, see 8.6 ‘Mounting the Sensor Mounting Plate.’

- 3) Disconnect the connector [1], and detach the cassette retry paper sensor [2].

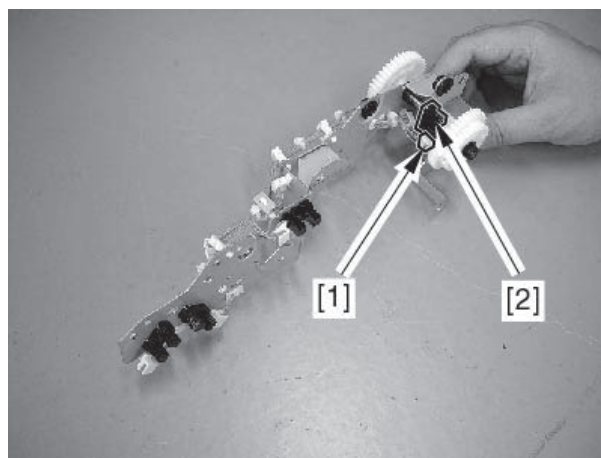

F05-808-01

8.9 Removing the Cassette Paper Sensor

- 1) Remove the pickup unit. (See 8.1 ‘Removing the Pickup Unit.’)
- 2) Remove the sensor mounting plate. (See 8.5 ‘Removing the Vertical Path Roller.’)



When attaching the sensor mounting plate, see 8.6 ‘Mounting the Sensor Mounting Plate.’

- 3) Disconnect the connector [1], and detach the cassette paper sensor [2].

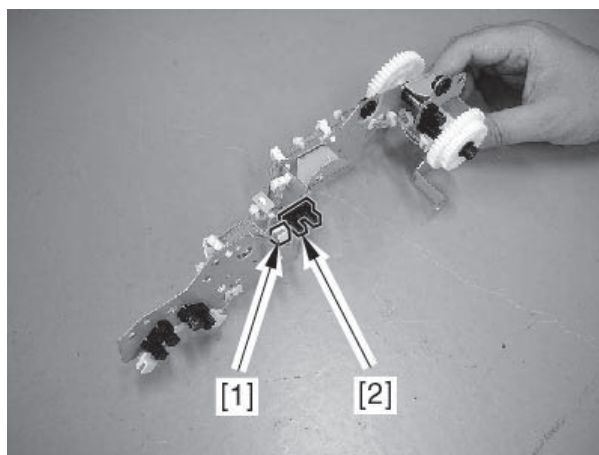

F05-809-01

8.10 Removing the Cassette Paper Level Sensor (A/B)

- 1) Remove the pickup unit. (See 8.1 ‘Removing the Pickup Unit.’)
- 2) Remove the sensor mounting plate. (See 8.5 ‘Removing the Vertical Path Roller.’)



When attaching the sensor mounting plate, see 8.6 ‘Mounting the Sensor Mounting Plate.’

- 3) Disconnect the connector [1], and remove the cassette paper sensor (A/B) [2].

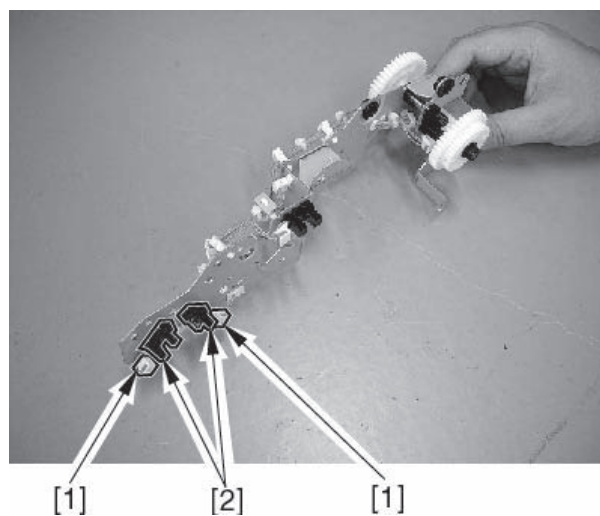

F05-810-01

8.11 Removing the Cassette Pickup Motor



Both cassette pickup 1 motor and cassette pickup 2 motor may be removed in the same way.

- 1) Remove the DC power supply unit. (See ‘Removing the DC Power Supply Unit.’)
- 2) Remove the manual feed cooling fan duct. (See 5.17 ‘Removing the Manual Feed Cooling Fan’ in Chapter 7.)
- 3) Remove the rear right cover.
- 4) Remove the grip [1].

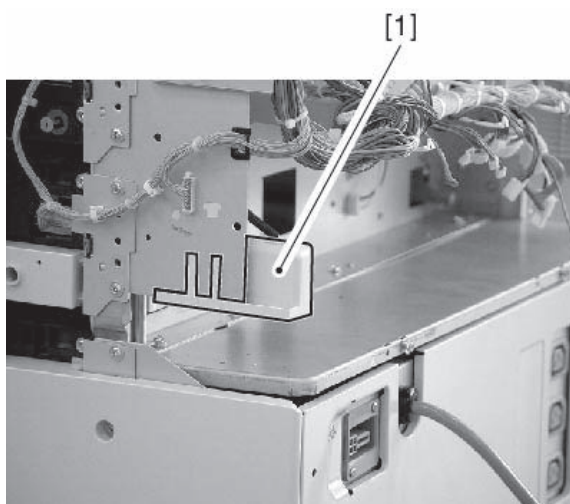

F05-811-01

- 5) Disconnect the connector [1], and remove the 4 screws [2]; then, detach the cassette pickup motor unit [3].

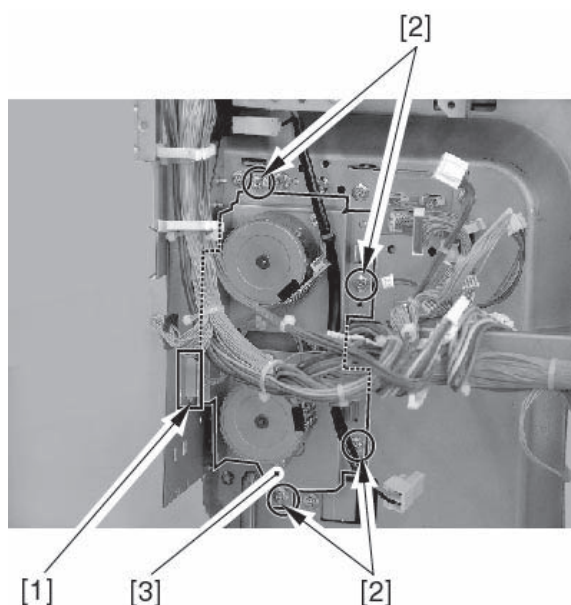

F05-811-02

- 6) Disconnect the connector [1], and remove the 2 screws [2]; then, detach the cassette pickup motor [3].

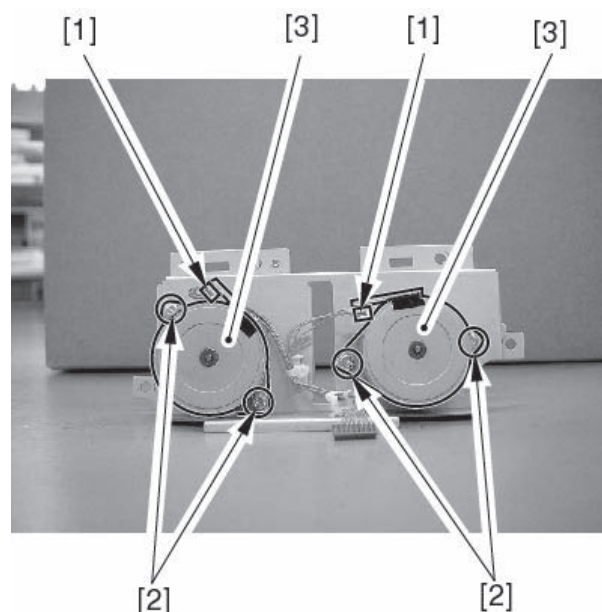

F05-811-03

8.12 Removing the Cassette Pickup Solenoid



The cassette pickup 1 solenoid and cassette pickup 2 solenoid may be removed in the same way.

- 1) Remove the pickup unit.
- 2) Disconnect the connector [1], and remove the 2 screws [2]; then, detach the cassette pickup solenoid [3].

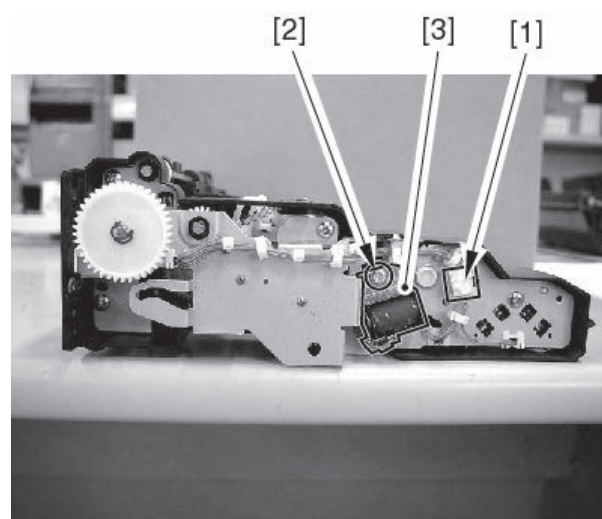

F05-812-01

8.13 Removing the Cassette Size Detecting Switch



The cassette 2 size detection unit may also be removed in the same way.

- 1) Slide out the cassette.
- 2) Remove the 4 screws [1], and detach the machine's lower left cover [2].

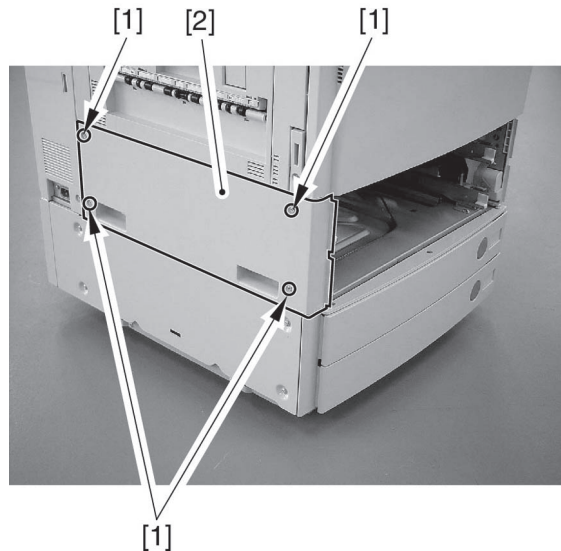

F05-813-01

- 3) Disconnect the connector [1], and push the protrusion [A] from the left to release the lock; then, detach the cassette size detection unit [2] for the machine's front.

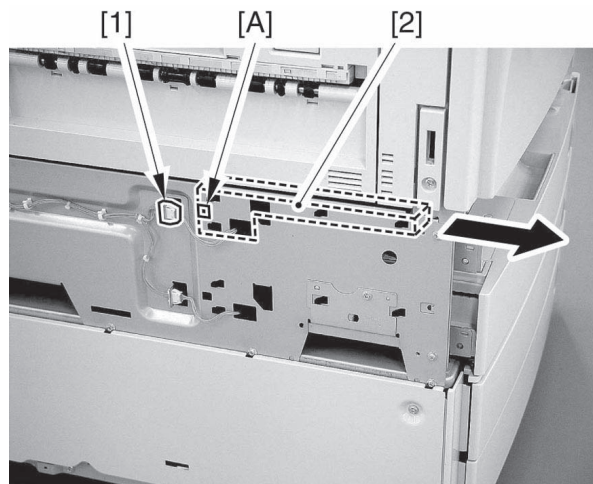

F05-813-02



When attaching the cassette size detection unit, try pushing the 4 protrusions into the holes of the machine's stay.

8.14 Removing the Fixing/Feeder Unit

- 1) Slide out the fixing/feeder unit.
- 2) Remove the 2 screws [1], and detach the fixing unit [2]

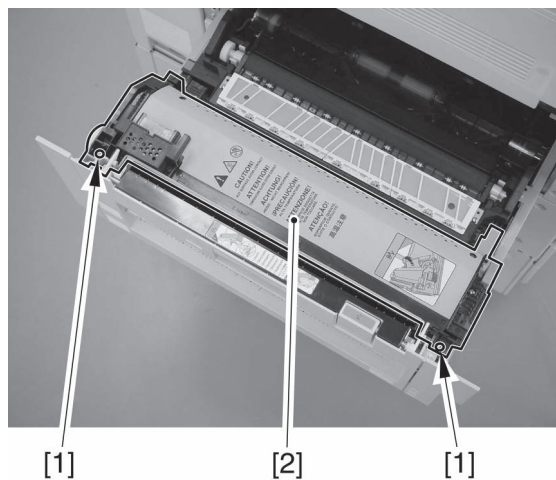

F05-814-01

- 3) Remove the 2 stoppers [1], and detach the fixing/feeder unit [2].

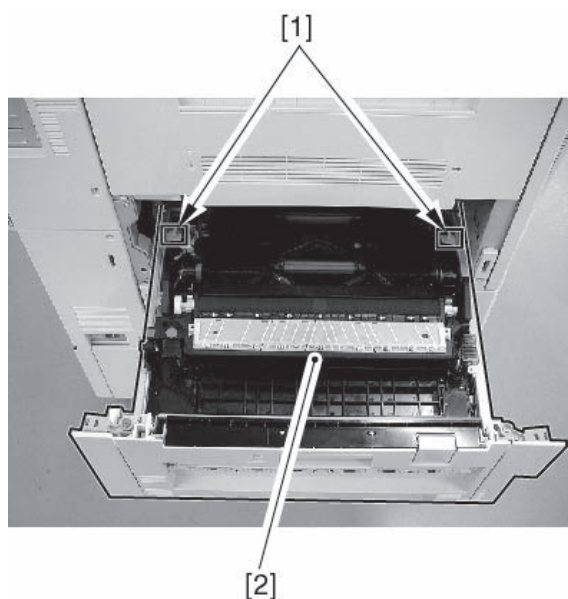

F05-814-02

8.15 When Replacing the Fixing/Feeder Unit

Make a test copy of the A3 Test Chart to see that the margin on the 2nd side is correct. Otherwise, use the following service mode to adjust it.

COPIER>ADJUST>FEED-ADJ>ADJ-REFE

8.16 Removing the Fixing/Feeder Unit Open/Closed Sensor

- 1) Remove the delivery vertical path unit.
(See 8.17 'Removing the Delivery Vertical Path Unit.')



Before detaching the fixing/feeder unit open/closed sensor mounting plate, be sure to mark its position using a scribe.

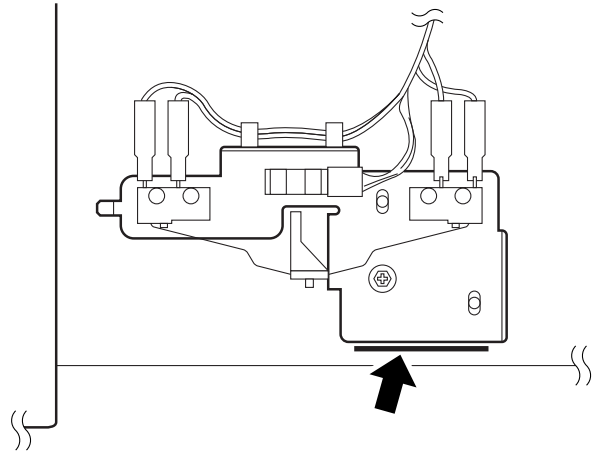

F05-816-01

- 2) Disconnect the connector [1] and the 4 terminals [2], and remove the screw [1]; then, detach the fixing/feeder unit open/closed sensor mounting plate [4].

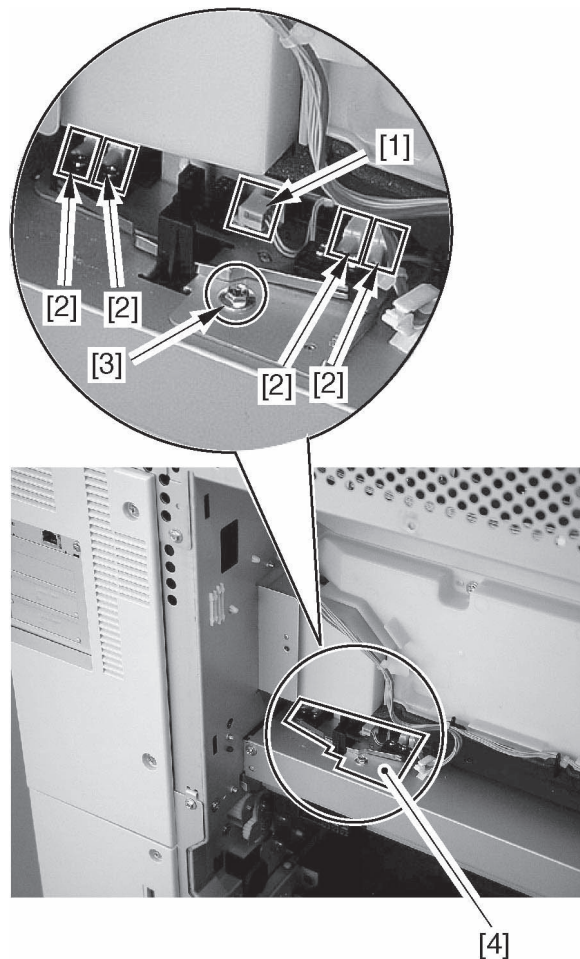

F05-816-02

- 3) Remove the fixing/feeder open/closed sensor [1].

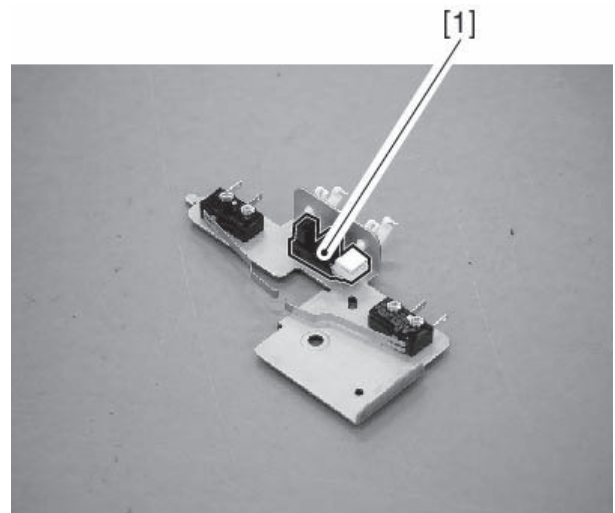

F05-816-03

8.17 Removing the Fixing/Feeder Unit Open/Closed Switch



The fixing/feeder unit open/closed switches 1 and 2 may be removed in the same way.

- 1) Remove the delivery vertical path unit. (See 8.17 'Removing the Delivery Vertical Path Unit.')



Before detaching the fixing/feeder unit, be sure to mark its position using a scribe.

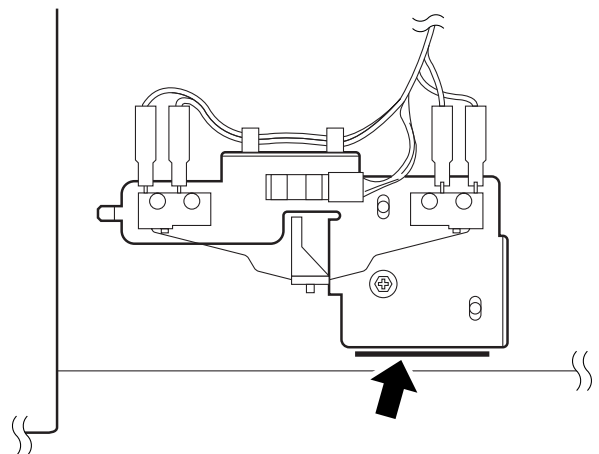

F05-817-01

- 2) Disconnect the connector [1] and the 4 terminals [2]; then, detach the fixing/feeder unit open/closed sensor mounting plate [2].

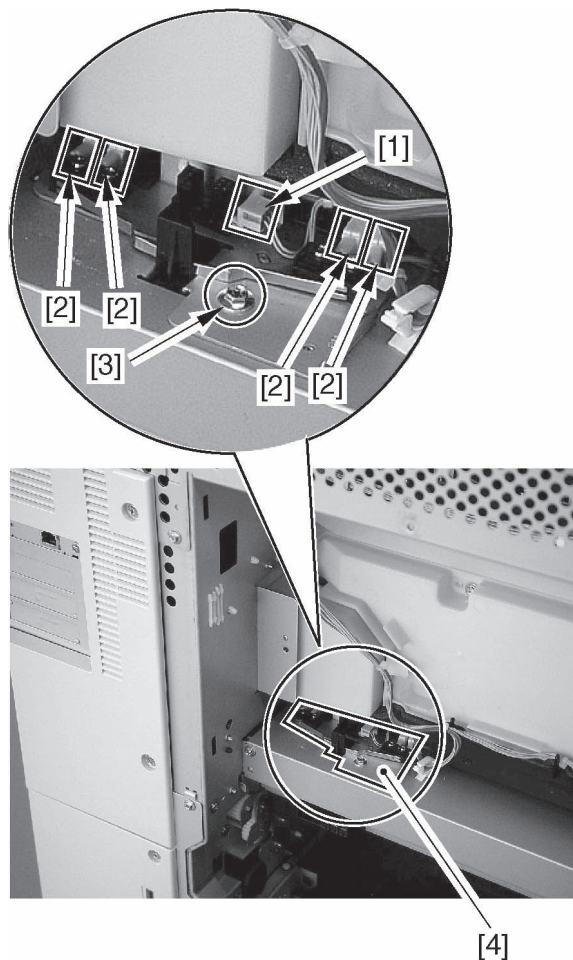

F05-817-02

- 3) Remove the 2 screws [1], and detach the fixing/feeder open/closed sensor [2].

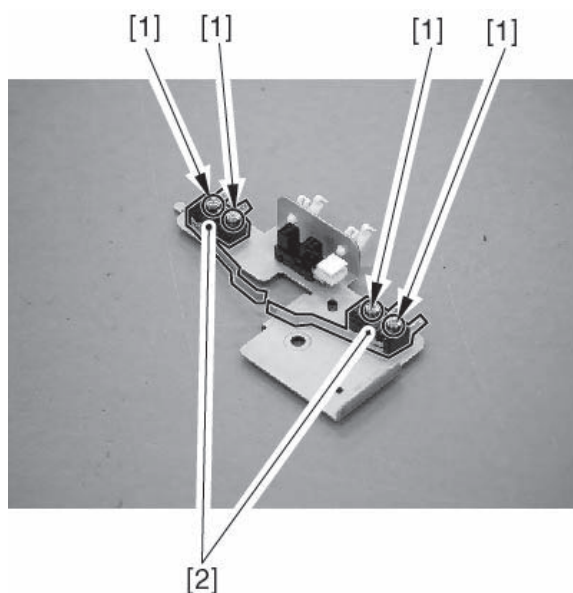

F05-817-03

8.18 Removing the Delivery Vertical Path Unit

- 1) Slide out the fixing/feeder unit.
- 2) Remove the 2 screws [1], and detach the center delivery tray [2].

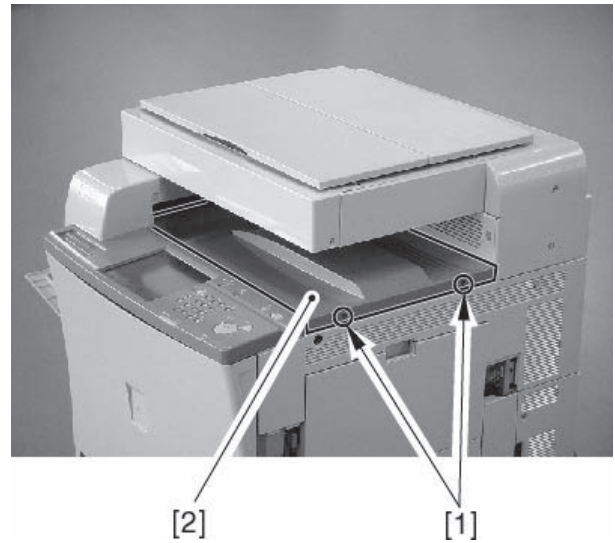

F05-818-01

- 3) Open the delivery vertical path cover [1], and remove the 2 screws [2]; then, detach the upper left cover [3].

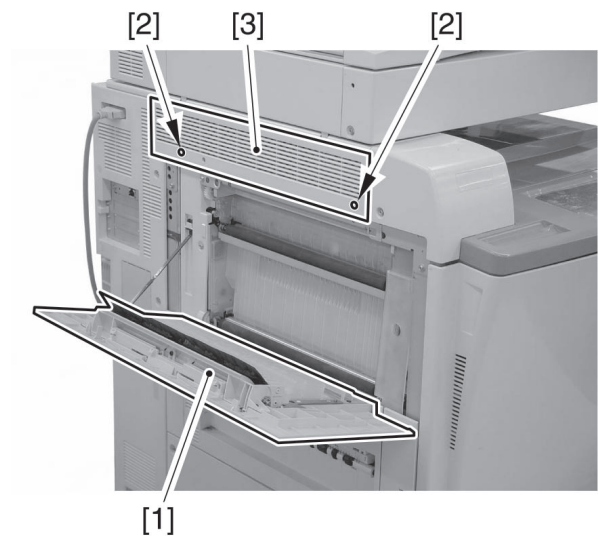

F05-818-02

- 4) Remove the screw [1], and detach the delivery internal cover [2]; then, detach the delivery vertical path cover [3].

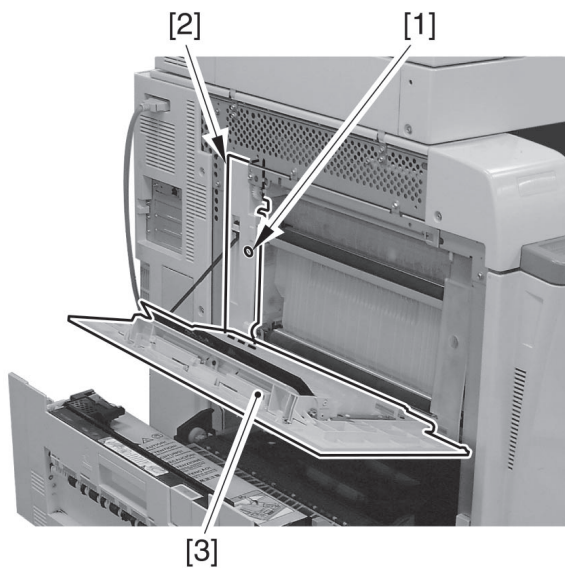

F05-818-03

- 5) Disconnect the 3 connectors [1], and remove the 4 screws [2]; then, detach the delivery vertical path unit [3].

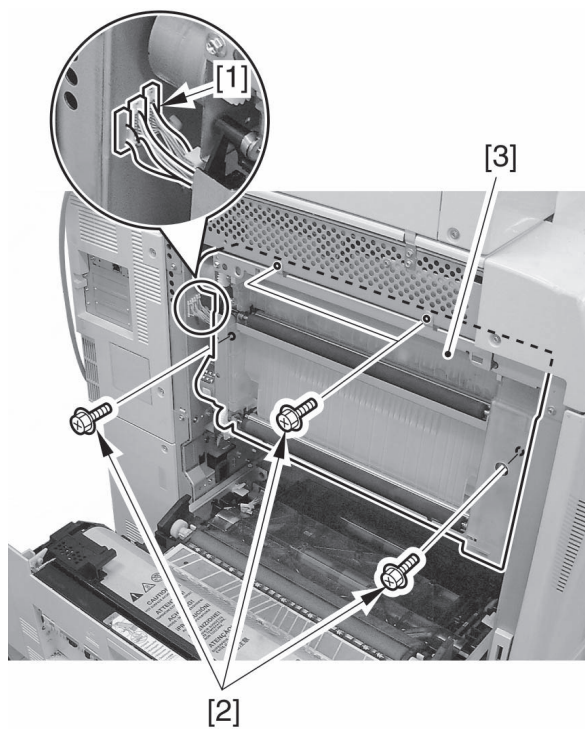

F05-818-04



When attaching, engage the left/right hook [1] found on the side of the delivery vertical path unit on the plate on the side of the machine, and secure it with screws. (Be sure to tighten the left screw first.)

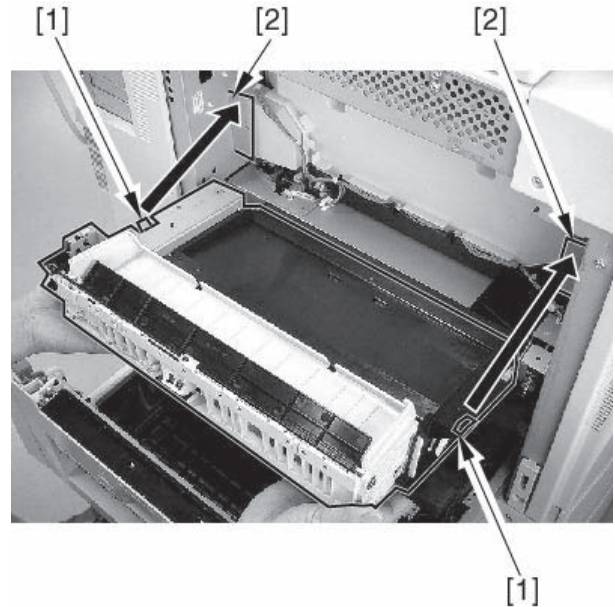

F05-818-05

8.19 Removing the Delivery Vertical Path Cover Open/Closed Sensor

- 1) Remove the delivery vertical path unit. (See 8.18 'Removing the Delivery Vertical Path Unit.')
- 2) Remove the screw [1], and detach the sensor mounting plate [2].

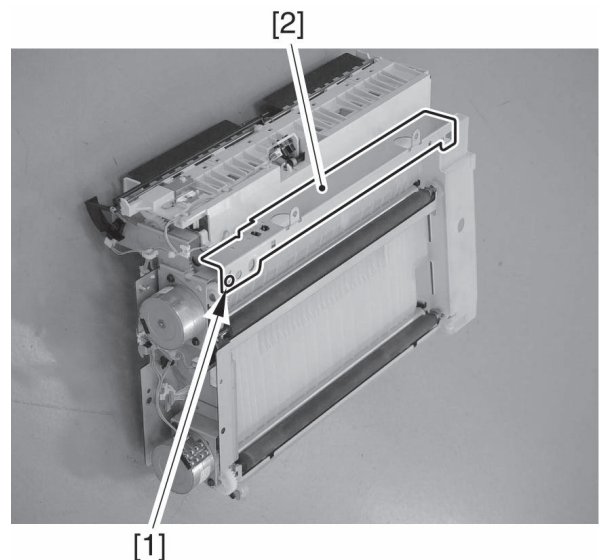

F05-819-01



When attaching the sensor mounting plate, mount it in place and then route the wires to facilitate the work.

- 3) Disconnect the connector [1], and remove the delivery vertical path cover open/closed sensor [2].

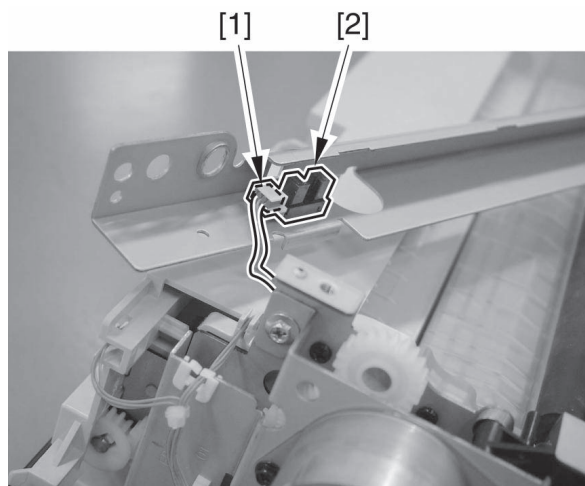

F05-819-02

8.20 Removing the Face-Down Delivery Sensor 1

- 1) Remove the delivery vertical path unit. (See 8.18 'Removing the Delivery Vertical Path Unit.')
- 2) Shift up the sensor flag [1] of the face-down delivery sensor 1, and pull it upward to detach.

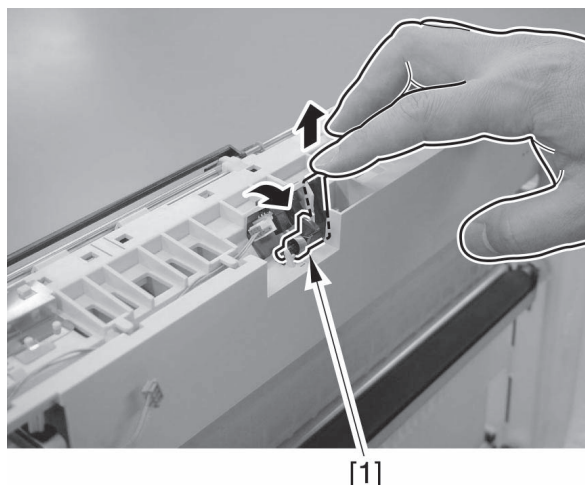

F05-820-01

- 3) Disconnect the connector [1], and remove the face-down delivery sensor 1 [2].

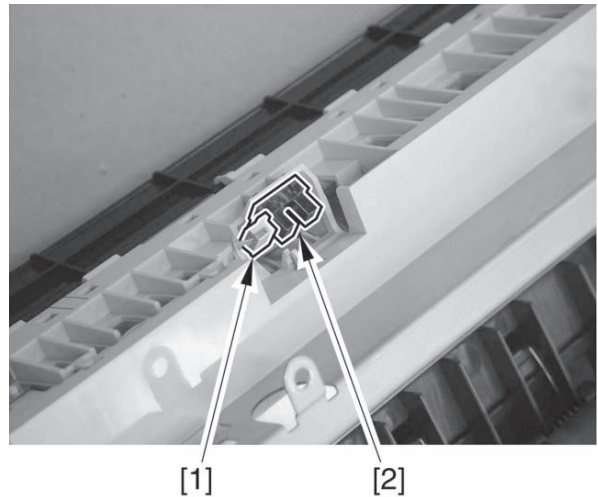

F05-820-02



The edge of the sensor flag is cut to an I-shape, permitting it to be removed upward.

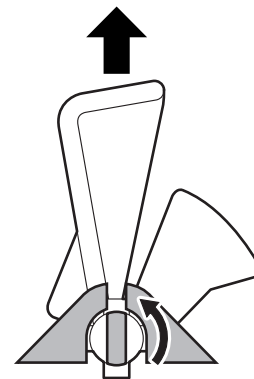

F06-820-03



When attaching the sensor flag, be sure to match the L-shaped area [A] of the spring against the groove [B] in the face-down delivery sub frame.

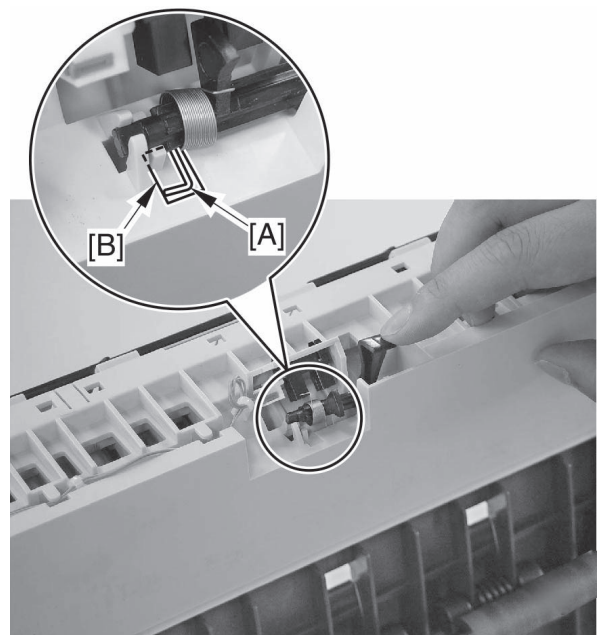

F05-820-04

8.21 Removing the Face-Down Delivery Sensor 2

- 1) Remove the delivery vertical path unit.
(See 8.18 'Removing the Delivery Vertical Path Unit.')
- 2) Remove the 2 screws [1]; then, detach the face-down delivery motor mounting plate [2].

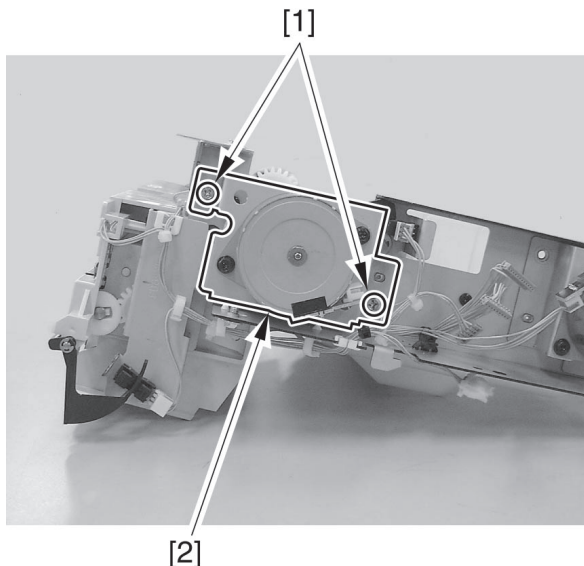

F05-821-01

- 3) Move the face-down delivery motor mounting plate [1], and detach the face-down delivery sensor 2 [2].

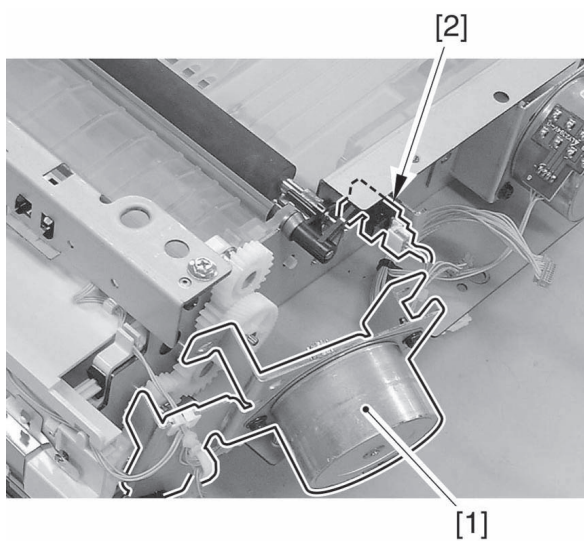

F05-821-02



When attaching the sensor flag [1], hook one end of the inside spring [2] and hook the other end on the flag.

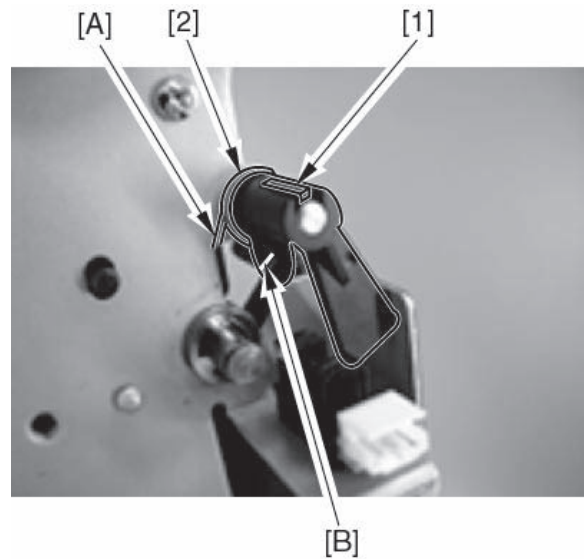

F05-821-03

8.22 Removing the Face-Down Delivery Roller 1

- 1) Remove the delivery vertical path unit. (See 8.18 'Removing the Delivery Vertical Path Unit.')
- 2) Remove the screw [1], and detach the sensor mounting plate [2].

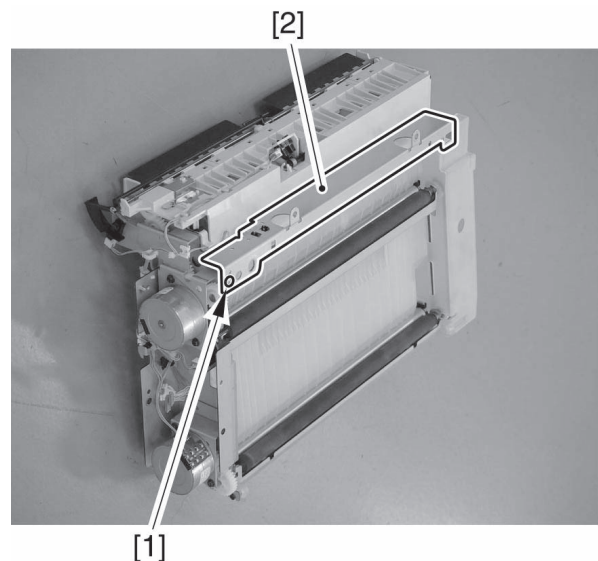

F05-822-01



When attaching the sensor mounting plate, secure it in place with screws first and then route the wire to facilitate the work.

- 3) Shift up the flag of the face-down delivery sensor 1, and pull it upward to detach.

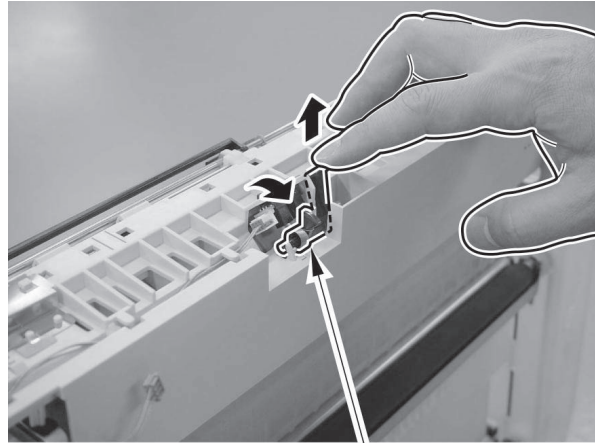

[1]

F05-822-02



The edge of the sensor flag is cut to an I-shape, permitting it to be removed upward.

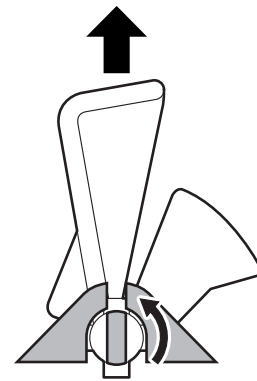

F05-822-03



When attaching the sensor flag, be sure to match the L-shaped area [A] of the spring against the groove [B] of the face-down delivery sub frame.

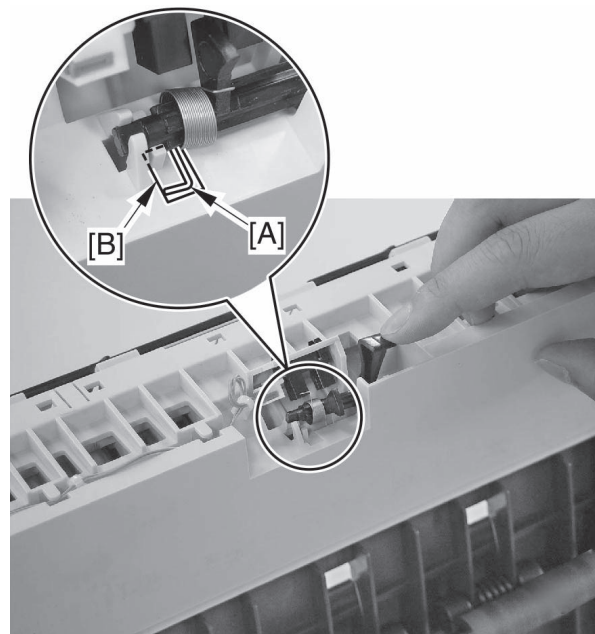

F05-822-04

- 4) Shift up the grounding leaf spring [1] using a flat-blade screwdriver, and free the 2 claws.

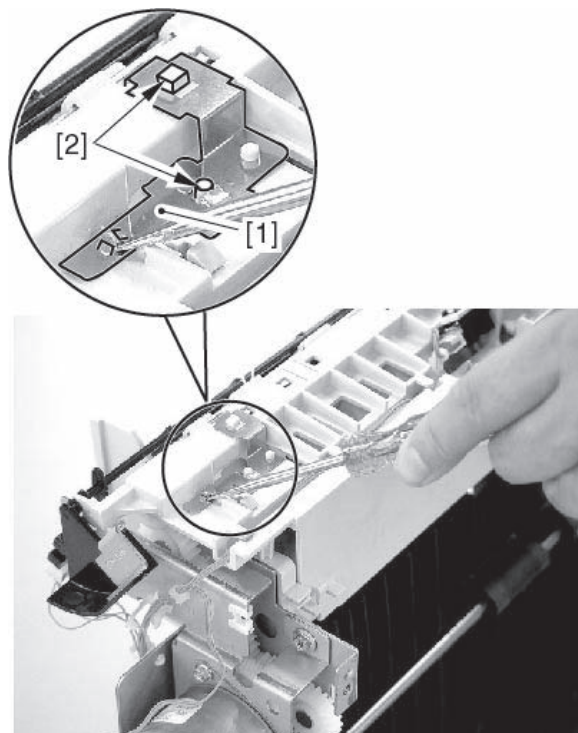

F05-822-05

- 5) Disconnect the connector [1], and detach the sensor cable [2] from the face-down delivery sub frame; then, remove the flag [3] of the face-down delivery sensor 1, and detach the face-down delivery sub frame [4].

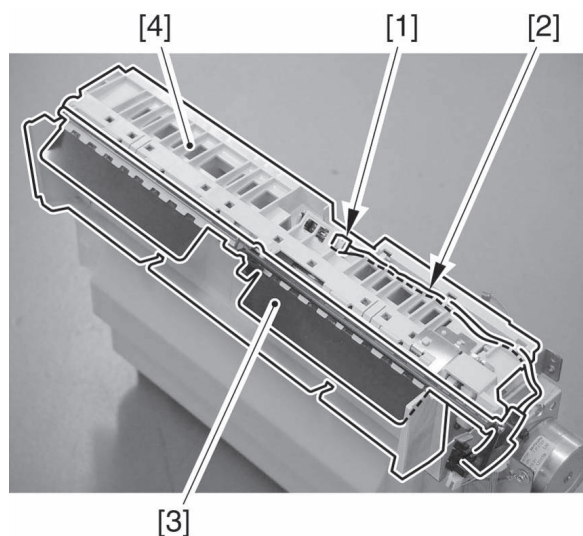

F05-822-06



When attaching, shape the grounding leaf plate removed in 3) into a half-loop, and work so that the frame plate [1] and the grounding leaf spring [2] are in contact.

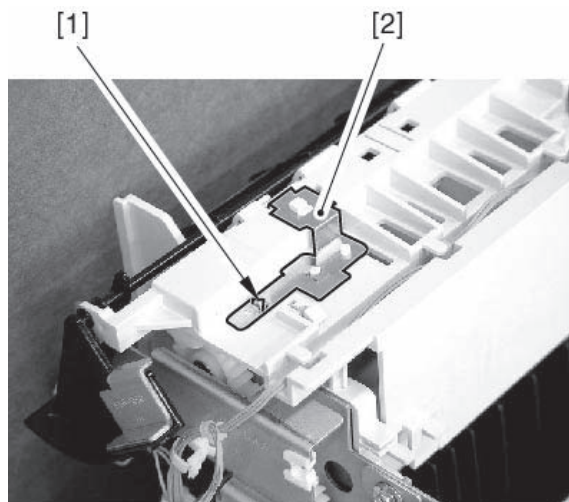

F05-822-07

- 6) Remove the E-ring [1] and the bushing [2], and remove the gear [3] and the bushing [4] found to the rear of the face-down delivery roller 1; then, detach the face-down delivery roller 1 [5].

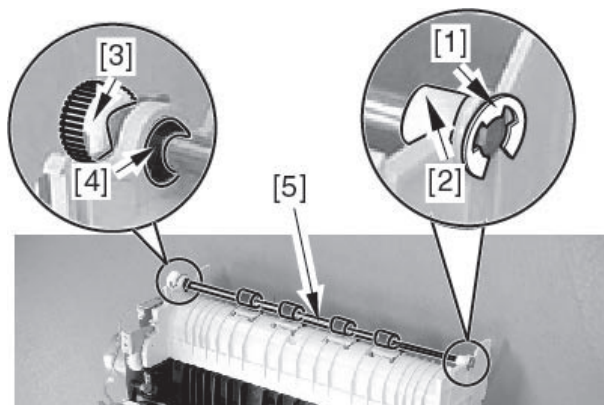

F05-822-08

8.23 Detaching the Face-Down Delivery Roller 1 Drive Belt

- 1) Remove the delivery vertical path unit.
- 2) Free the protrusion [1] of the belt pulley (upper or lower) from the groove of the shaft, and shift it; then, detach the belt [2].

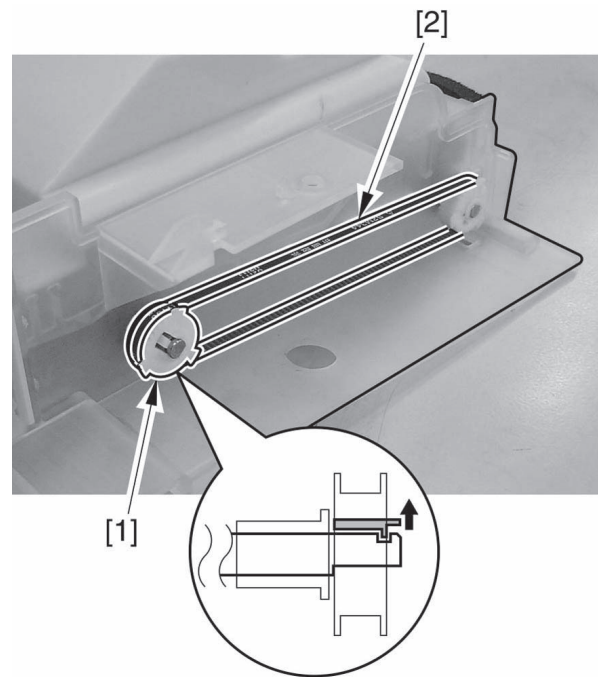

F05-823-01

8.24 Removing the Face-Down Delivery Motor

- 1) Remove the delivery vertical path unit.
- 2) Disconnect the connector [1], and remove the 2 screws [2]; then, detach the face-down delivery motor [3].

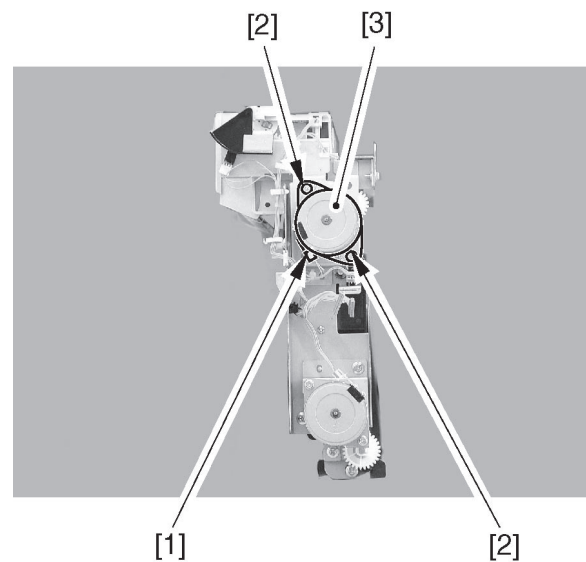

F05-824-01

8.25 Mounting the Face-Down Delivery Guide Sheet

If you have to replace the sheet [1] attached to the face-down delivery guide, be sure that the sheet will not extend beyond the edge of the guide [2].

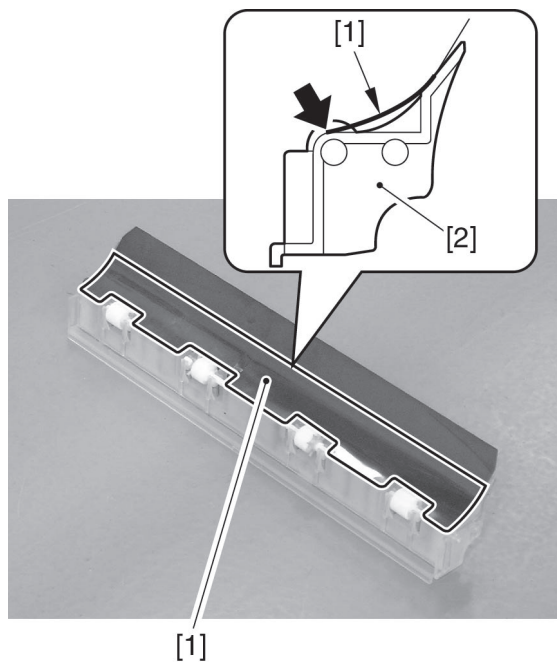

F05-825-01

8.26 Removing the Face-Up Delivery Roller

- 1) Remove the fixing/feeder unit.
- 2) Open the fixing/feeder unit cover.
- 3) Remove the screw [1] at the rear, grounding wire [2], and E-ring [3]; then, release the link [4].

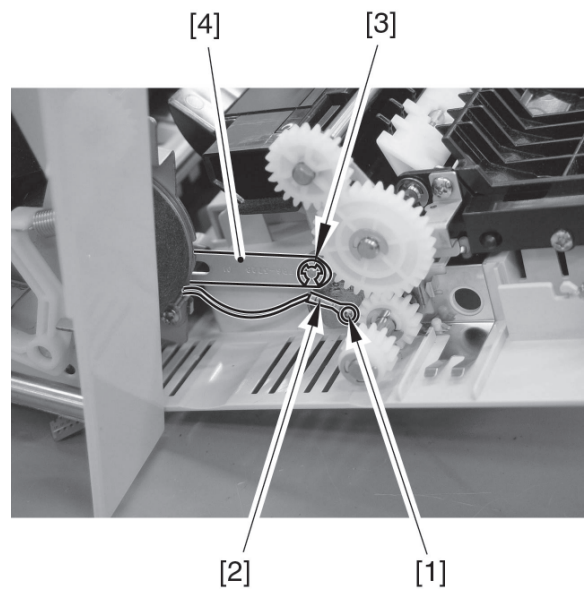

F05-826-01

- 4) Remove the screw [1] at the front and the cover fixing pin [2]; then, detach the fixing/feeder unit cover.

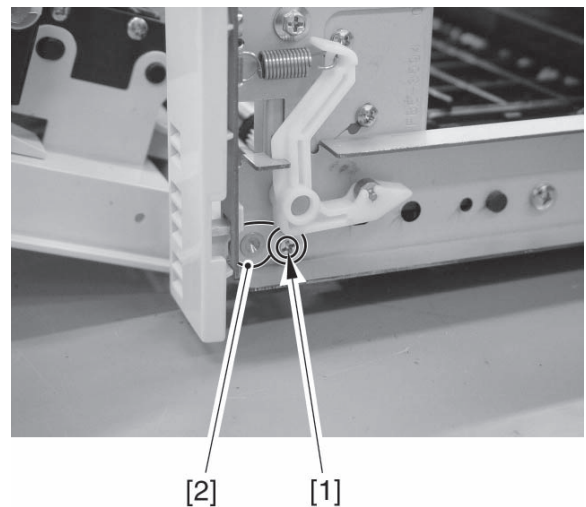

F05-826-02

- 5) Remove the internal delivery roller.
(See 8.43 'Removing the Internal Delivery Roller.')
- 6) Remove the 2 screws [1], and detach the lower guide 2 [2].

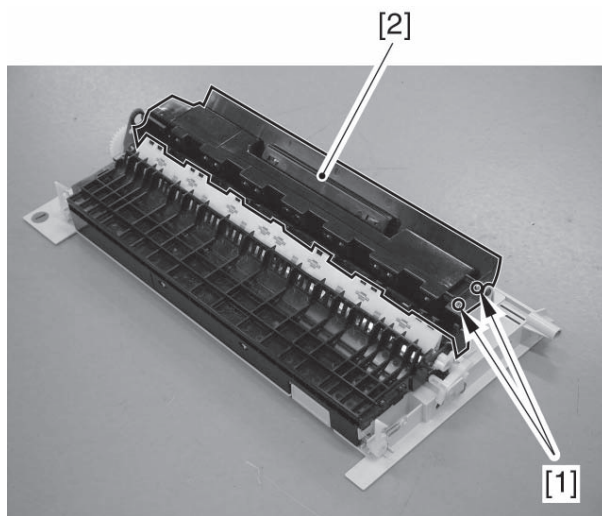

F05-826-03

- 7) Remove the E-ring [1] at the rear, and detach the gear [2].

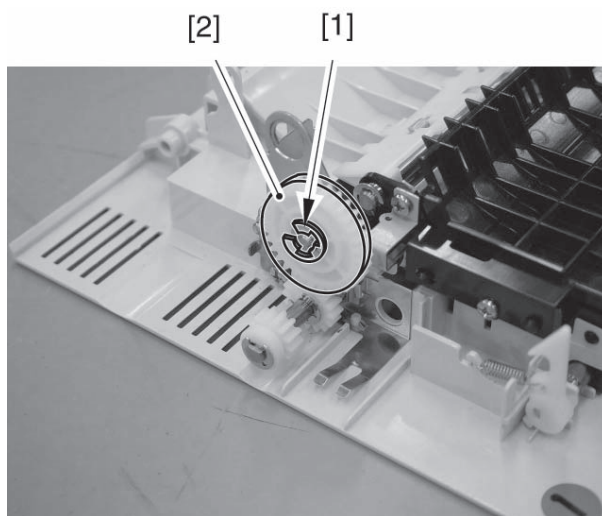

F05-826-04

8)



The spring [1] hooked on the flapper of the upper guide is small and can easily be lost. Detach it in advance.

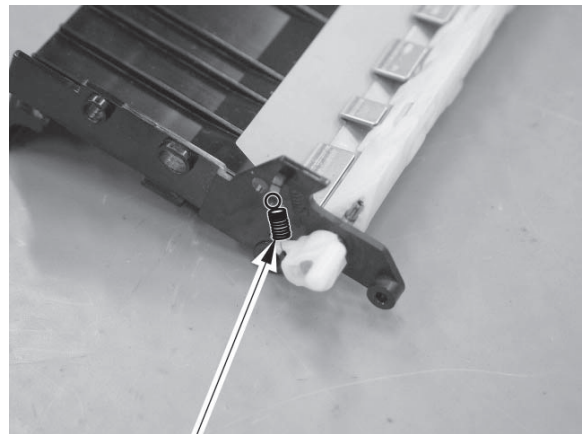

[1]

F05-826-05

Remove the screw [2] of the gear mounting plate [1], and remove the screw [3]; then, detach the upper guide [4].

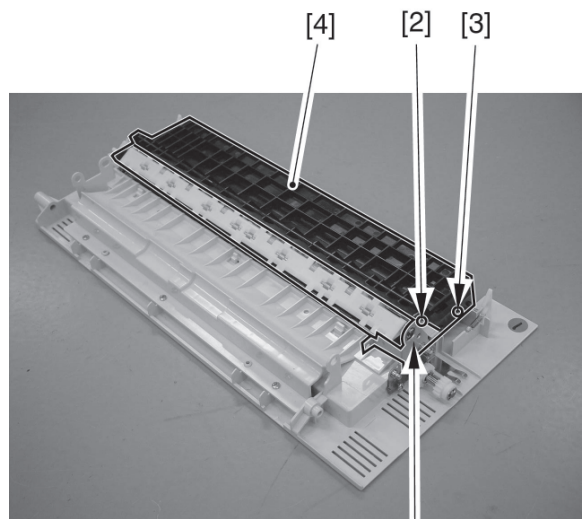

[1]

F05-826-06

9) Remove the 3 screws [1], and detach the lower guide [2].

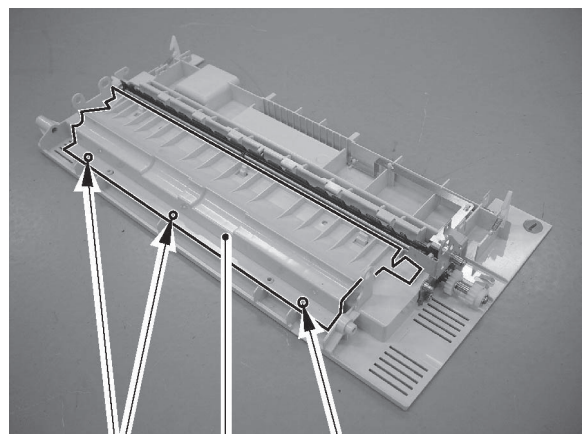

[1]

[2]

[1]

F05-826-07

10)



When detaching the gear [3], be sure to pay attention so as not to lose the parallel pin found at the rear.

Remove the 3 E-rings [1], gear [2], bushing [4], and gear mounting plate [5] at the rear.

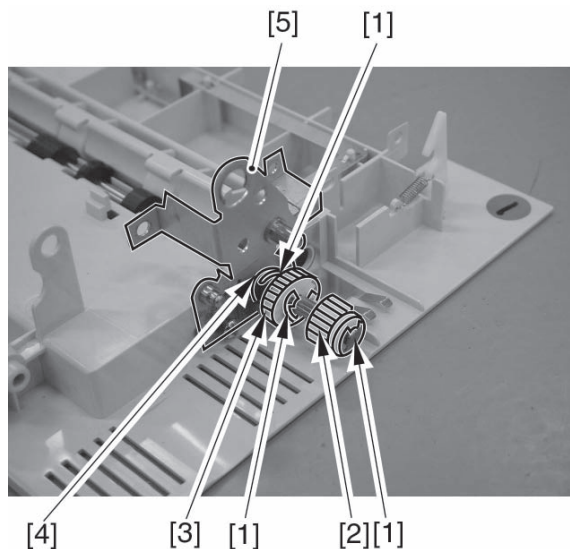

F05-826-08

11) Remove the E-ring [1] and the bushing [2] at the front; then, detach the face-up delivery roller [3].

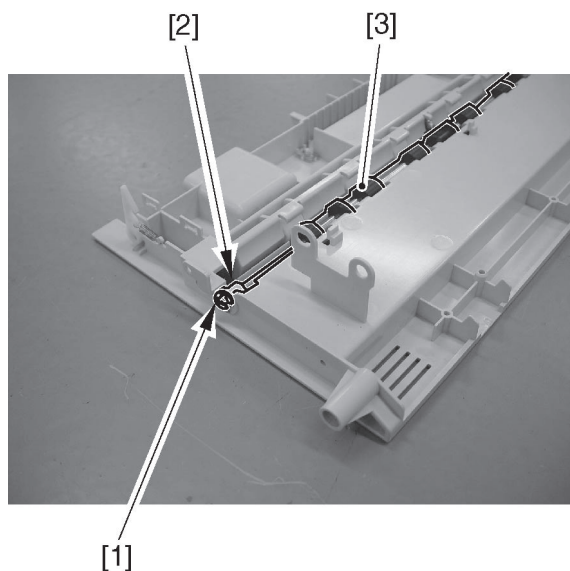

F05-826-09

8.27 Delivery Vertical Path Rollers

8.27.1 Removing the Delivery Vertical Path Roller 1

- 1) Remove the delivery vertical path unit.
- 2) Remove the face-down delivery sensor 2. (See 8.21 'Removing the Face-Down Delivery Sensor 2.')
- 3) Remove the gear [1], and detach the belt [2], and then remove the bushing [3].

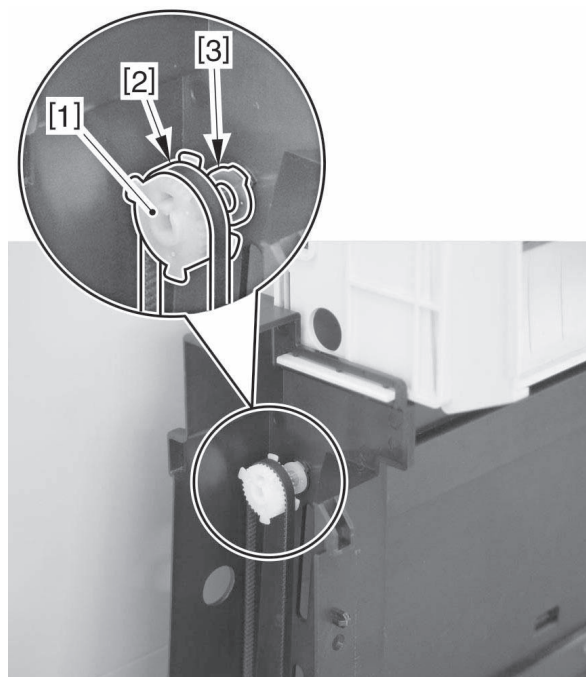

F05-827-01

- 4) Remove the roller cover [1].

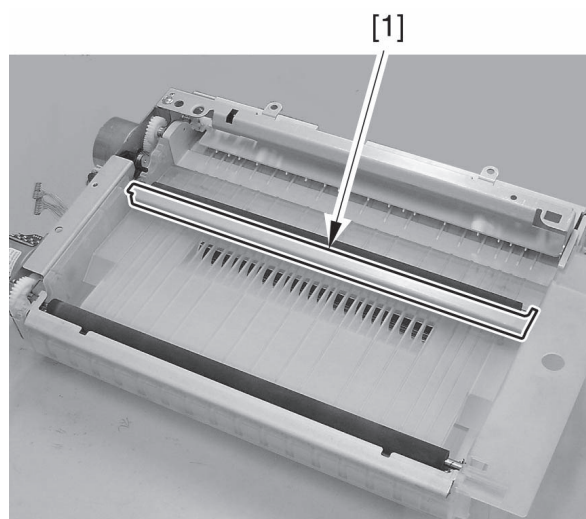

F05-827-02

- 5) Remove the E-ring [1] and the bushing [2] at the front; then, remove the roller [3].

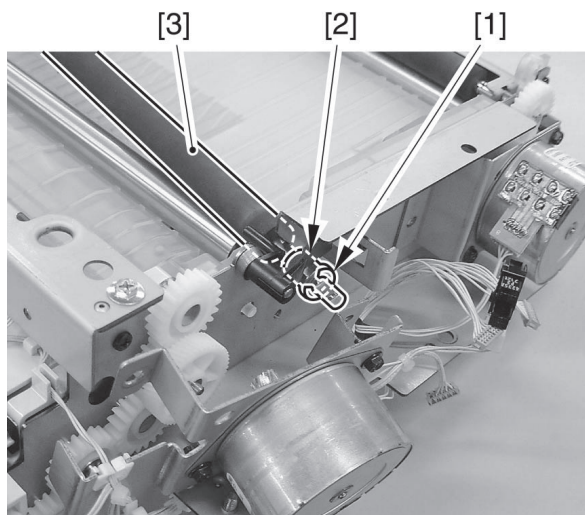

F05-827-03

8.27.2 Removing the Delivery Vertical Path Roller 2

- 1) Remove the delivery vertical path unit.
- 2) Remove the gear [1] and the bushing [2].

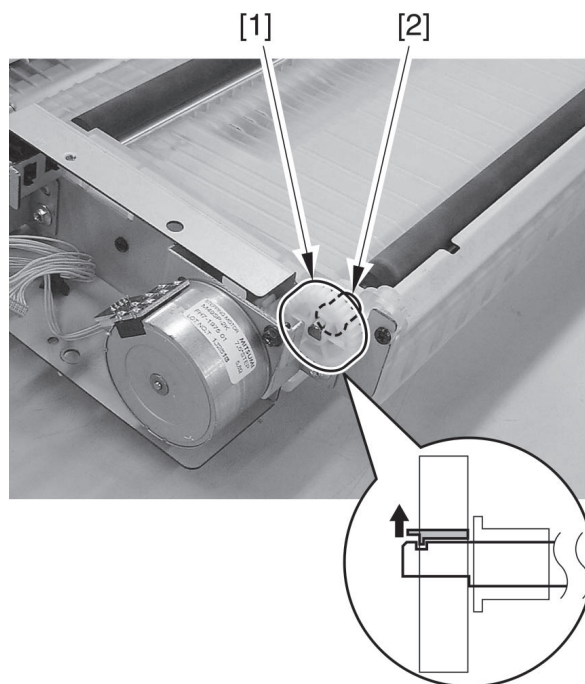

F05-827-04

- 3) Remove the gear [1] and detach the belt [2] at the rear; then, remove the bushing [3], and detach the delivery vertical roller 2 [4].

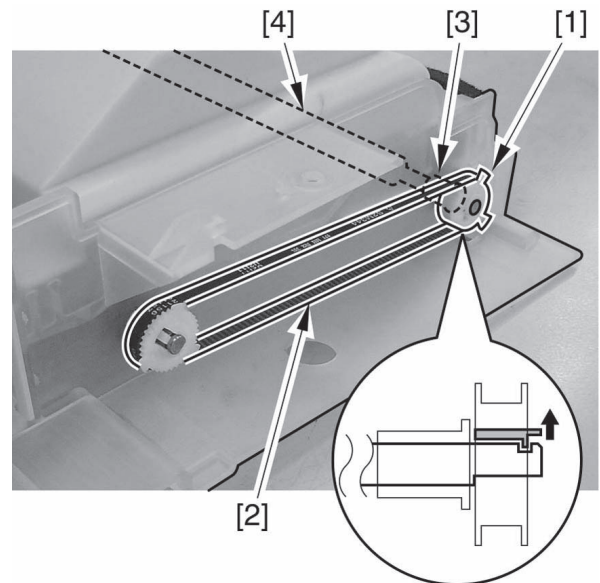

F05-827-05

8.28 Delivery Vertical Path Heat Discharge Fan

- 1) Remove the delivery vertical path unit.
- 2) Remove the 3 screws [1], and detach the delivery vertical path heat discharge fan cover [2].

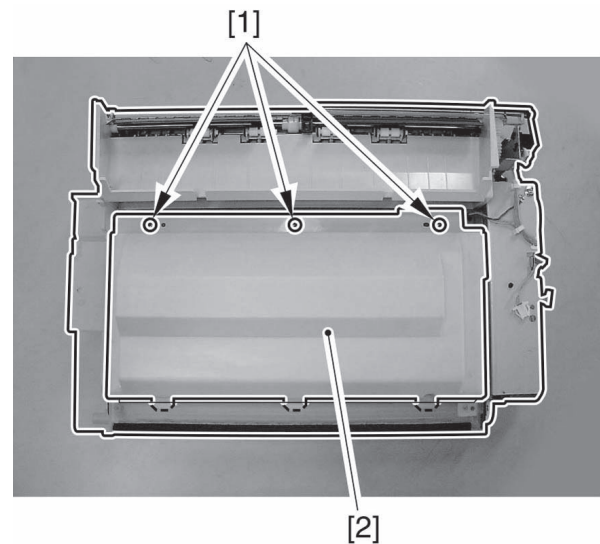

F05-828-01

- 3) Disconnect the connector [1], and remove the 2 screws [2]; then, detach the delivery vertical path heat discharge fan [3].

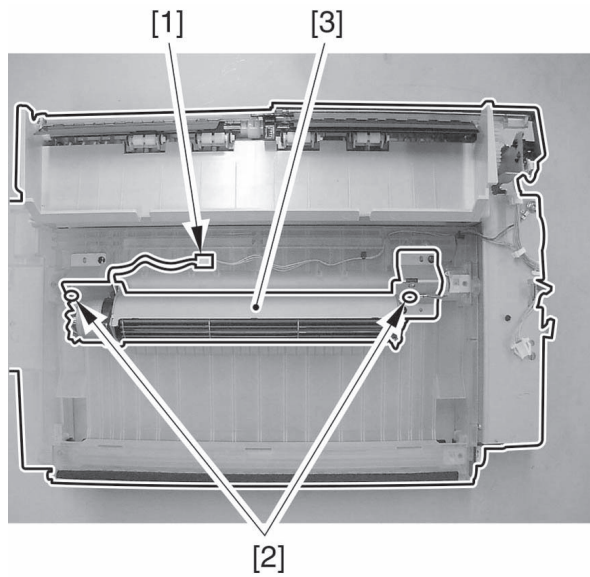

F05-828-02



1. When mounting the delivery vertical path heat discharge fan, be sure that the following are correctly arranged under the plastic sheet [4] as indicated: harness [1] of the fan, harness from the machine side [2], and connector of the harness [3].
2. When mounting the delivery vertical path heat discharge fan cover, be sure that there is no biting of the wire in the area [1] indicated in the figure.

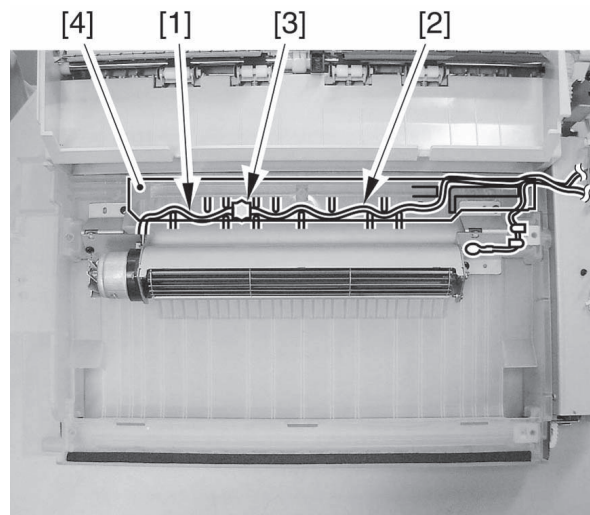

F05-828-03

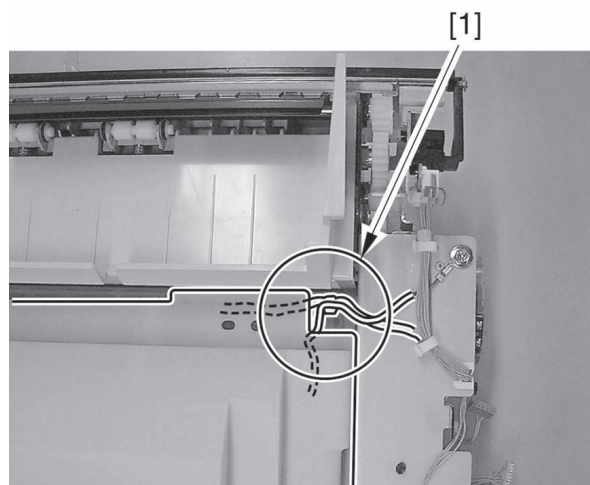

F05-828-04

8.29 Removing the Delivery Vertical Path Motor

- 1) Remove the delivery vertical path unit.
- 2) Disconnect the connector [1], and remove the 2 screws [2]; then, detach the delivery vertical path motor [3].

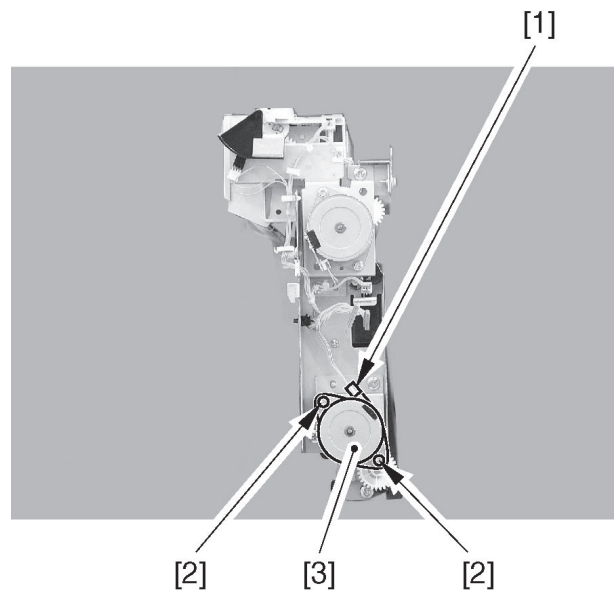

F05-829-01

8.30 Removing the Center Delivery Tray Full Sensor

- 1) Remove the delivery vertical path unit.
- 2) Remove the sensor flag [1]; then, disconnect the connector [2], and detach the center delivery tray full sensor [3].

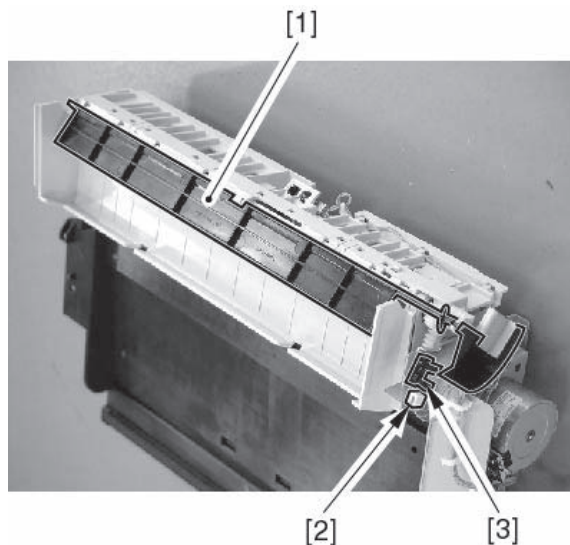

F05-830-01

8.31 Removing the Delivery Path Switching Solenoid 1

- 1) Remove the delivery vertical path unit.
- 2) Open the front cover, and remove the screw [1]; then, detach the cleaner fan cover [2].

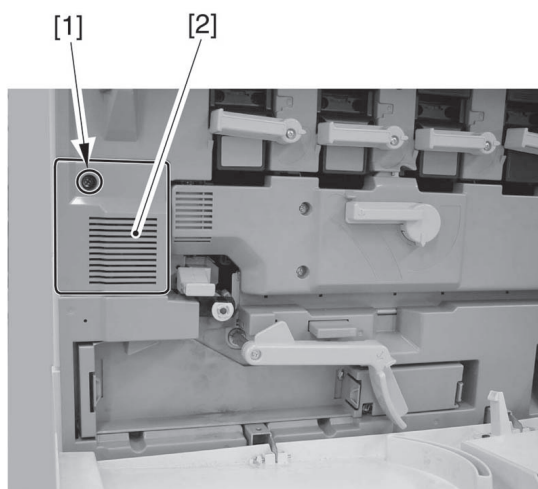

F05-831-01

- 3) Disconnect the connector [1], and remove the 2 screws [2]; then, detach the cleaner fan unit [3].

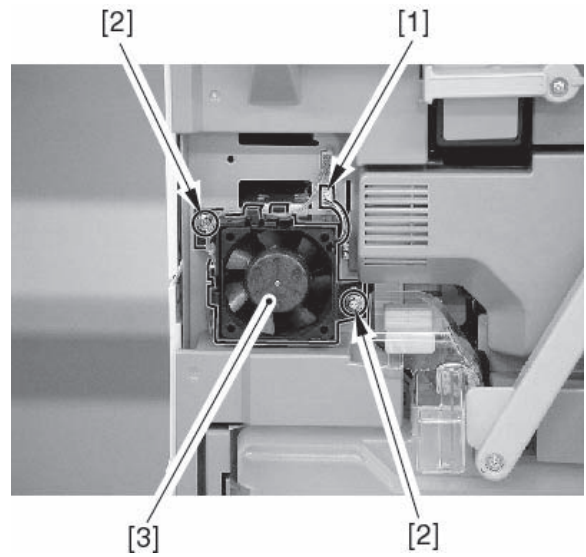

F05-831-02

- 4) Disconnect the connector [1], and remove the screw [2]; then, detach the delivery path switching solenoid 1 [3].

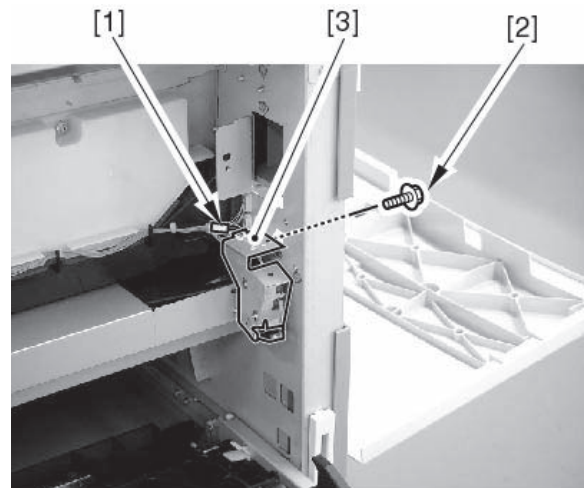

F05-831-03

8.32 Removing the Delivery Path Switching Solenoid 2

- 1) Open the fixing/feeder unit cover.
- 2) Remove the screw [1], and disconnect the connector [2]; then, detach the delivery path switching solenoid 2 [3] together with the mounting plate.

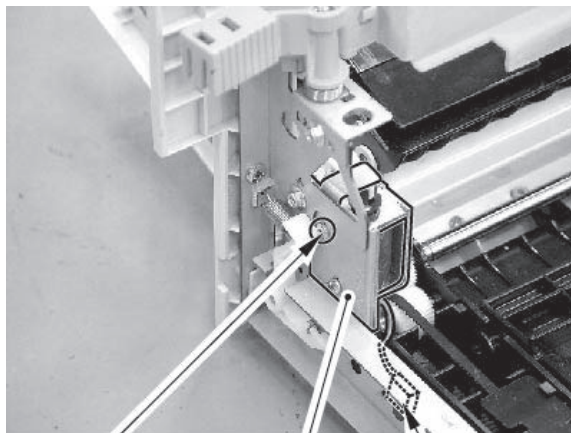

[1] [3] [2]

F05-832-01

8.33 Removing the Duplex Registration Clutch

- 1) Remove the fixing/feeder unit. (See 8.14 ‘Removing the Fixing/Feeder Unit.’)
- 2) Disconnect the connector [1] of the duplex feeder motor from the base side.

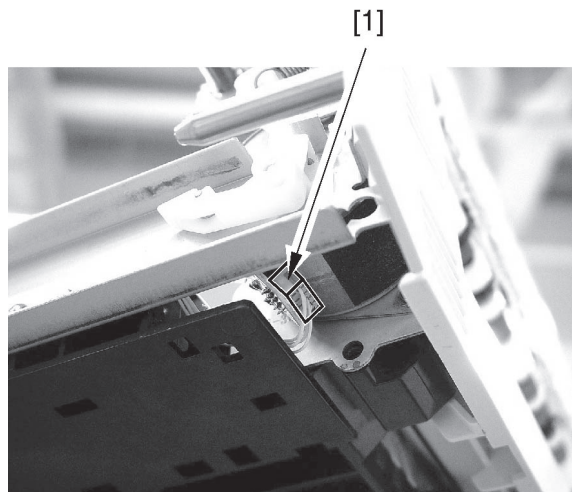

F05-833-01

- 3) Remove the duplex open/close guide [1].

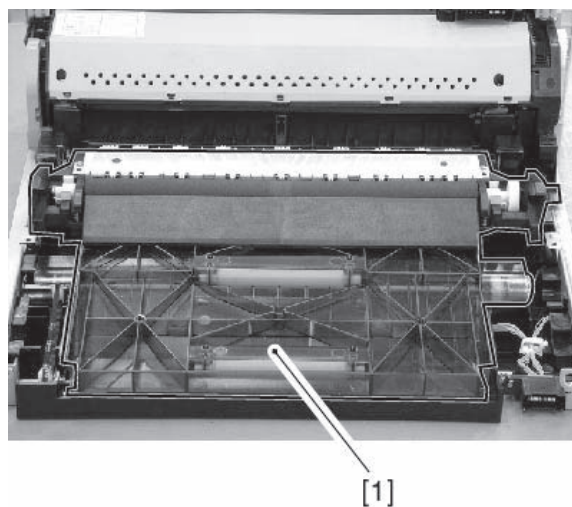

F05-833-02

4) Remove the 2 E-rings [1].

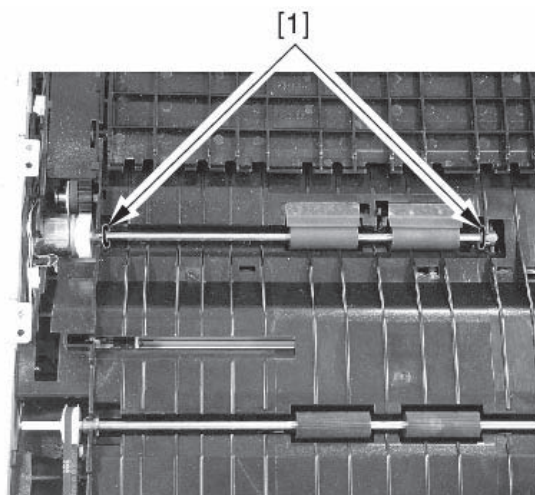

F05-833-03

5) Slide the bushing [1] to free the duplex feed roller 3 [2].

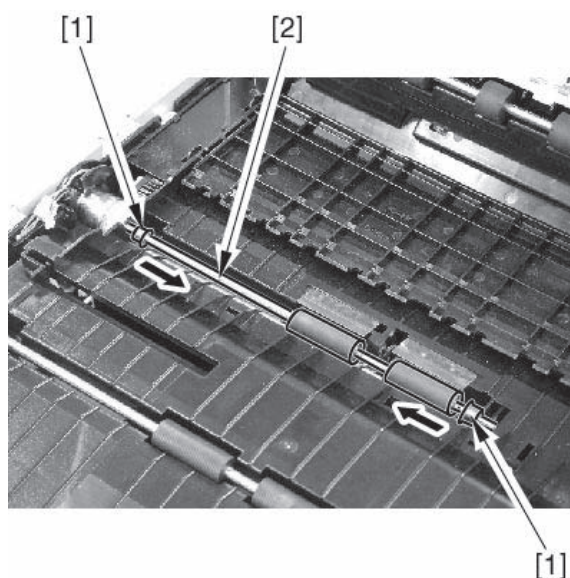

F05-833-04



When attaching it, fit it while turning the duplex feed roller 3 [2] so as not to bend the sheet [1] of the duplex guide plate. (Do not shift up the sheet by hand.)

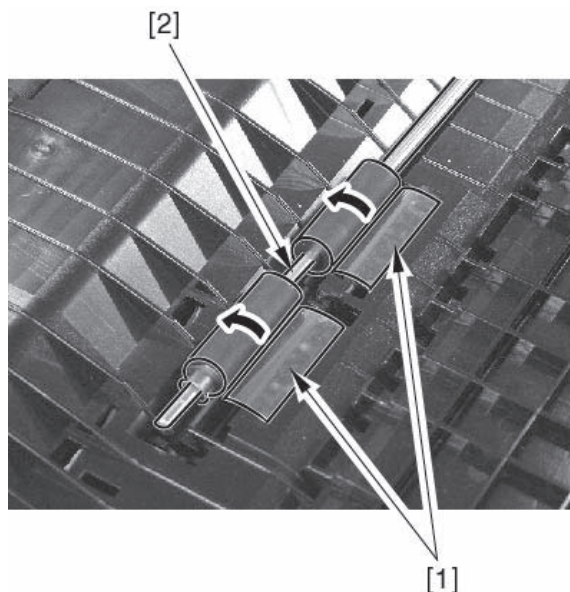

F05-833-05

- 6) Disconnect the connector [1], and remove the clutch stop [2]; then, pull the duplex registration clutch [3] upward to detach.

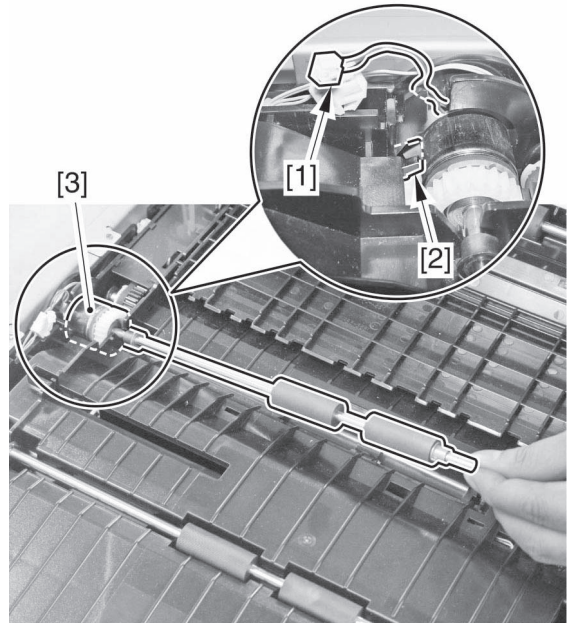

F05-833-06

- 7) Remove the E-ring [1], and detach the duplex registration clutch [2].

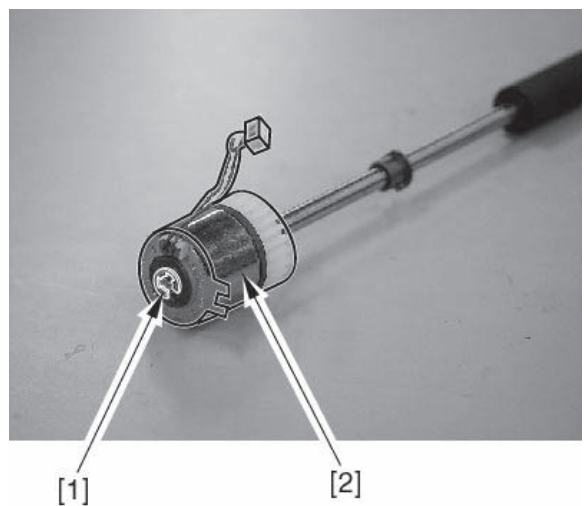

F05-833-07

8.34 Removing the Horizontal Registration Motor

- 1) Remove the fixing feeder unit. (See 8.4 'Removing the Fixing Feeder Unit.')
- 2) Remove the fixing unit.
- 3) Remove the duplex open/closed guide.



1. When placing the fixing feeder unit upright, be sure to use paper to prevent dirt from collecting.
2. If you forgot to use paper, make a double-sided test copy before ending the work.

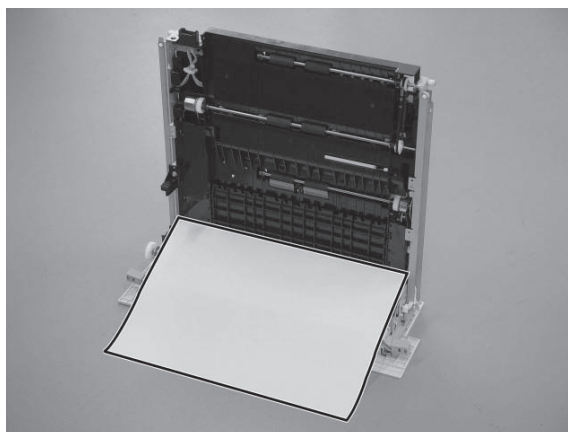

F05-834-01

- 4) Stand it so that the fixing feeder unit cover is at the bottom.
- 5) Free the 6 snap-ons [A] and the 3 hooks [B]; then, detach the sheet [1] from behind the fixing feeder assembly.

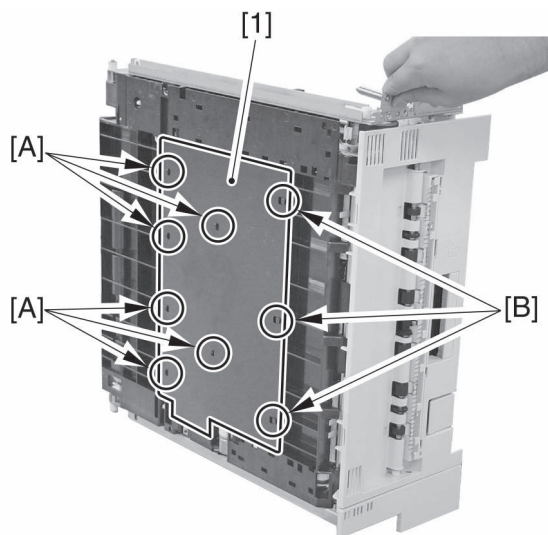

F05-834-02

- 6) Disconnect the connector [1], and remove the 2 screws [2]; then, detach the horizontal registration motor support plate [3].

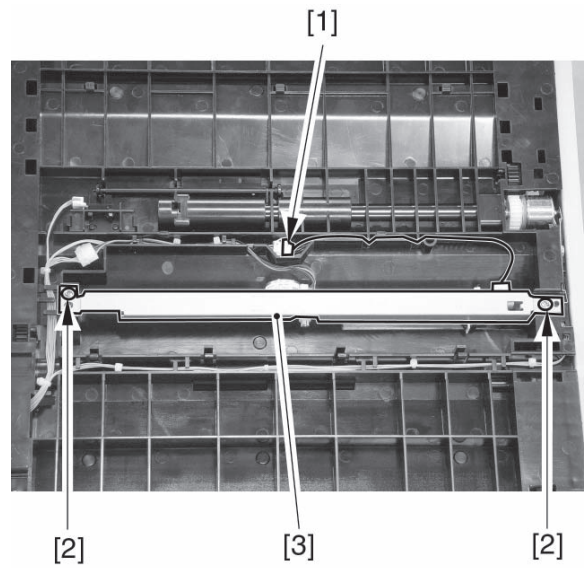

F05-834-03



1. When attaching the horizontal registration motor support plate [1], be sure to bring the horizontal registration motor support plate firmly in contact with the grounding lead spring [2] found under the guide plate.
2. After replacement, check to make sure that the sensor flag moves smoothly.

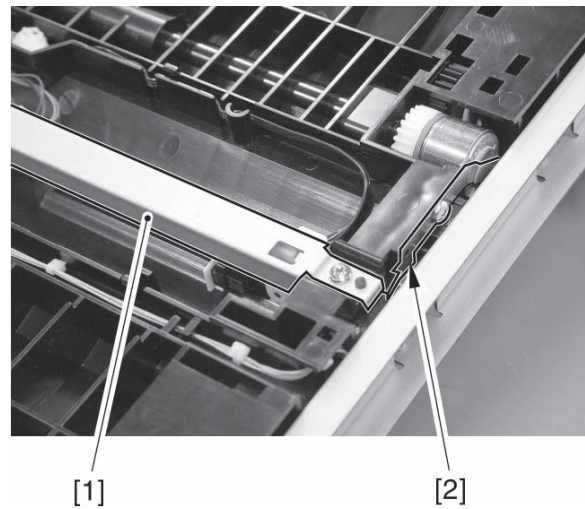

F05-834-04

- 7) Disconnect the connector [1], and remove the 2 screws [2]; then, detach the horizontal registration motor [3].

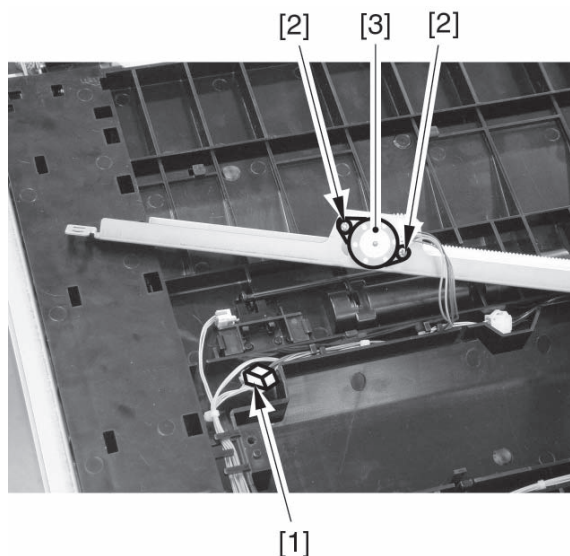

F05-834-05

8.35 After Replacing the Horizontal Registration Motor

Make a test copy of the A3 Test Chart, and check to see that the margin on the 2nd side is correct; otherwise, use the following service mode to make adjustments:

COPIER>ADJUST>FEED-ADJ>ADJ-REFE

8.36 Removing the Duplex Registration Sensor

- 1) Remove the fixing feeder unit. (See 8.14 'Removing the Fixing Feeder Unit.')
- 2) Remove the sheet found on the back of the fixing feeder assembly. (See 8.34 'Removing the Horizontal Registration Motor.')
- 3) Disconnect the connector [1], and remove the 2 screws [2]; then, detach the horizontal registration motor support plate [3].

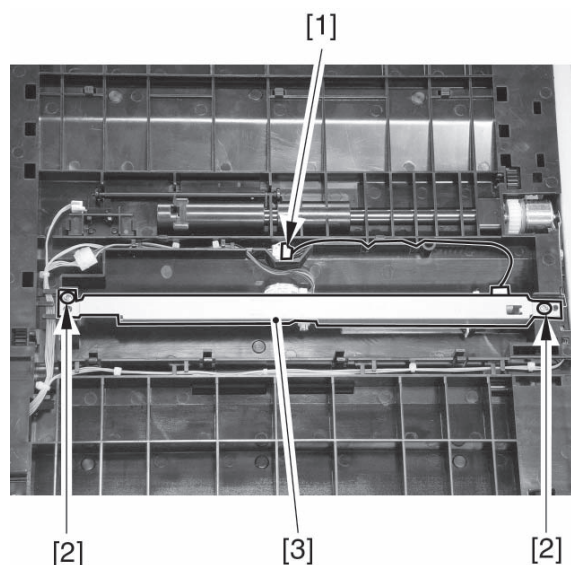

F05-836-01



When attaching the horizontal registration motor support plate [1], be sure to bring the horizontal registration motor support plate firmly into contact with the grounding leaf spring [2] found under the guide plate.

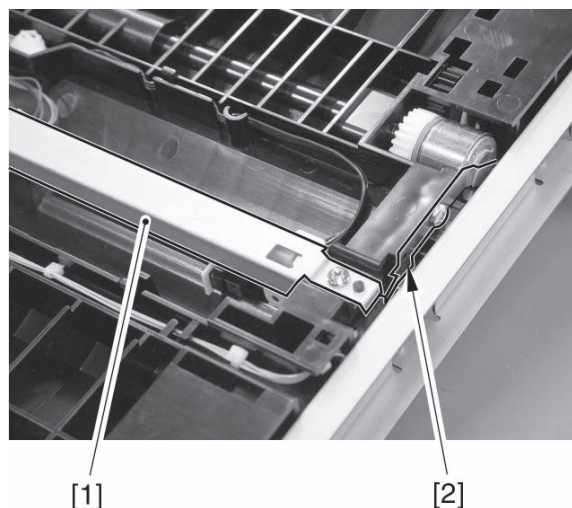

F05-836-02

- 4) Disconnect the connector [1], and detach the duplex horizontal registration sensor [2].

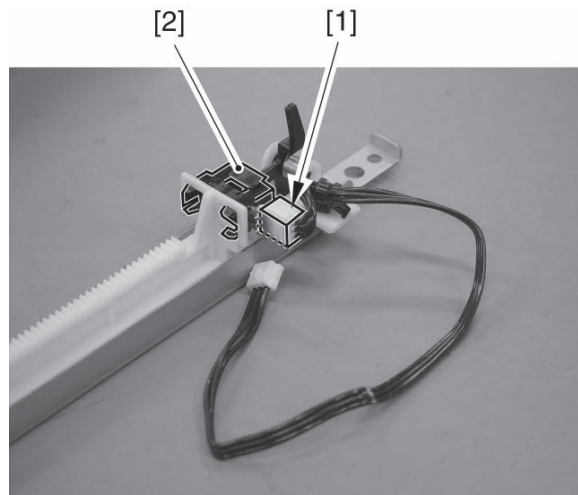

F05-836-03



Be sure to match the protrusion [B] of the harness guide found behind the guide plate against the area [A] marked on the flat cable [1] coming from the duplex horizontal registration sensor. (If you twist it inadvertently, the loop area will not move smoothly.) After replacement, check to make sure that the sensor flag moves smoothly.

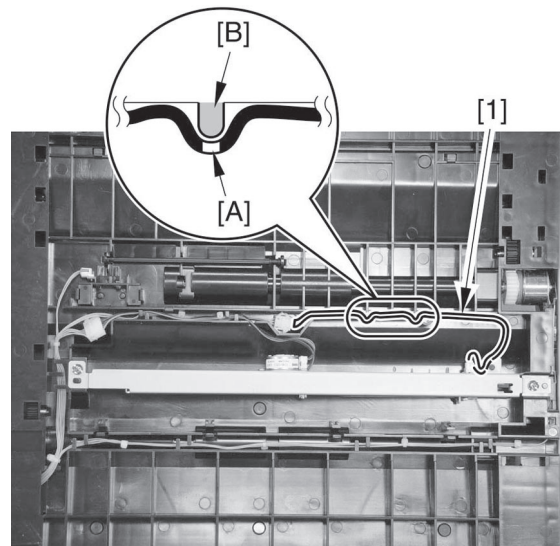

F05-836-04

8.37 After Replacing the Duplex Horizontal Registration Sensor

Make a test copy of the A3 Test Chart, and check that the margin on the 2nd side is correct; otherwise, use the following service mode to make adjustments:

COPIER>ADJUST>FEED-ADJ>ADJ-REFE

8.38 Removing the Duplex Pickup Clutch

- 1) Remove the fixing feeder unit.
- 2) Remove the fixing unit. (See 8.14 'Removing the Fixing Feeder Unit.')
- 3) Open the cover of the fixing feeder unit.
- 4) Remove the duplex open/close guide.
(See 8.33 'See the Duplex Registration Clutch.')
- 5) Remove the 2 E-rings [1].

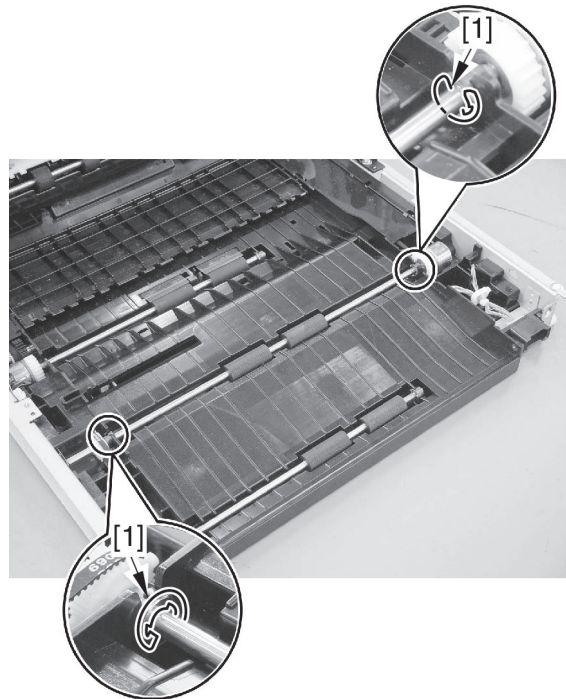

F05-838-01

- 6) Shift the bushing [1] to the inside of the duplex feeder guide.

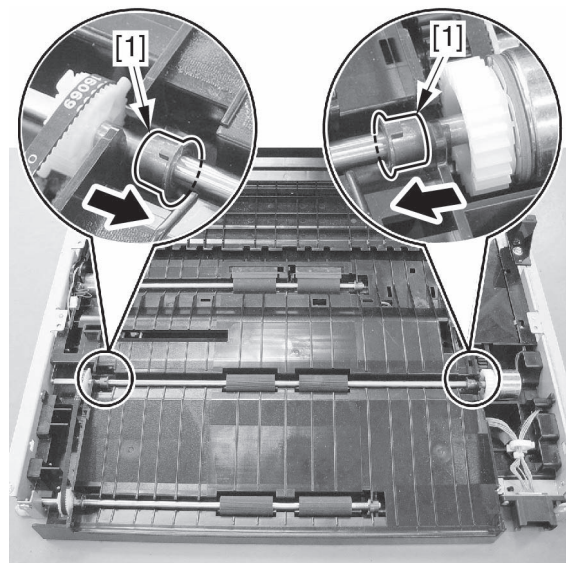

F05-838-02

- 7) Disconnect the connector [1] of the duplex pickup clutch.

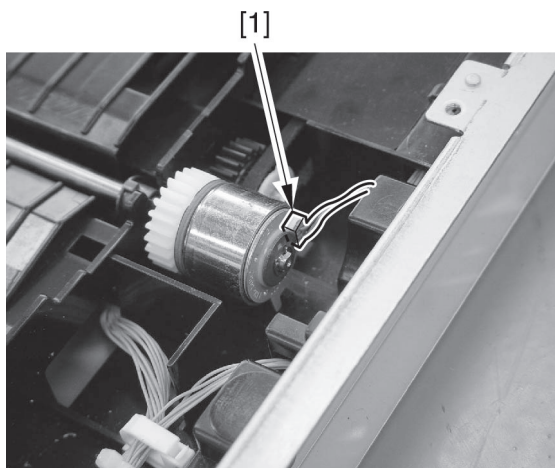

F05-838-03

- 8) Remove the roller shaft, and remove the E-ring [1]; then, detach the duplex pickup clutch [2].

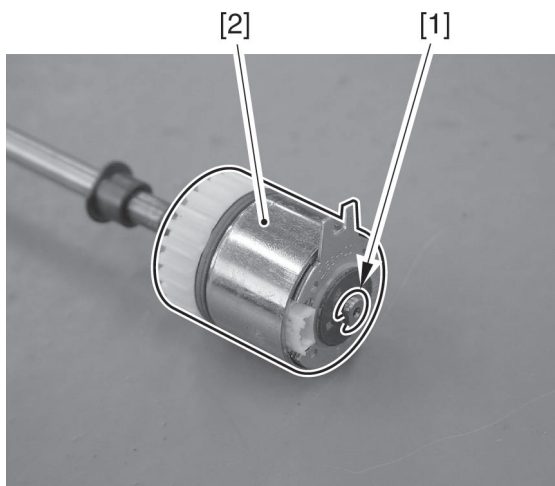

F05-838-04



When attaching, be sure that the stop [A] of the clutch is at the bottommost.

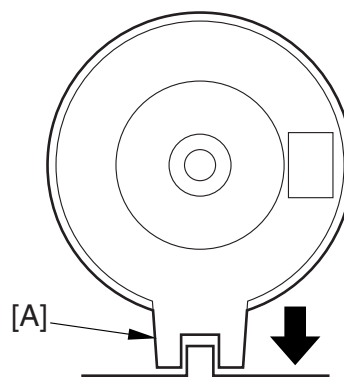

F05-838-05



Make sure that the front side of the roller shaft is in contact with the leaf spring [1].

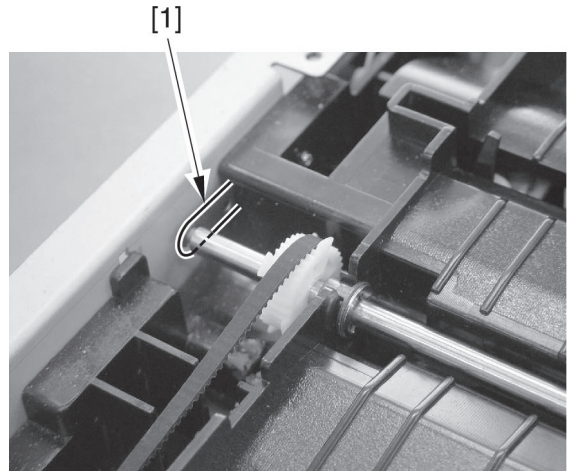

F05-838-06

8.39 Removing the Duplex Feeder Motor

- 1) Remove the fixing feeder unit. (See 8.14 'Removing the Fixing Feeder Unit.')
- 2) Disconnect the connector [1] of the duplex feeder motor from the bottom.

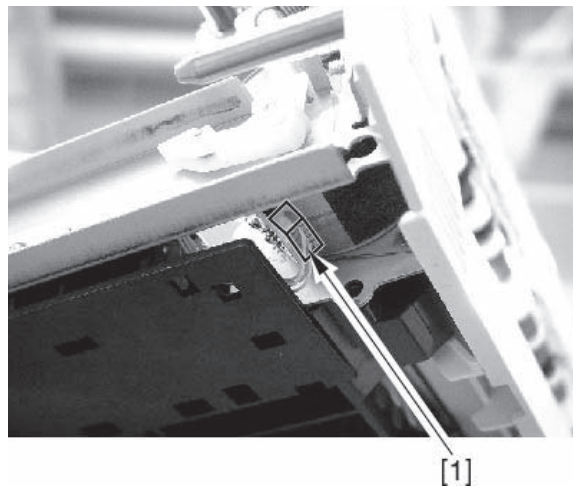

F05-839-01

- 3) Open the cover of the fixing feeder unit [1].

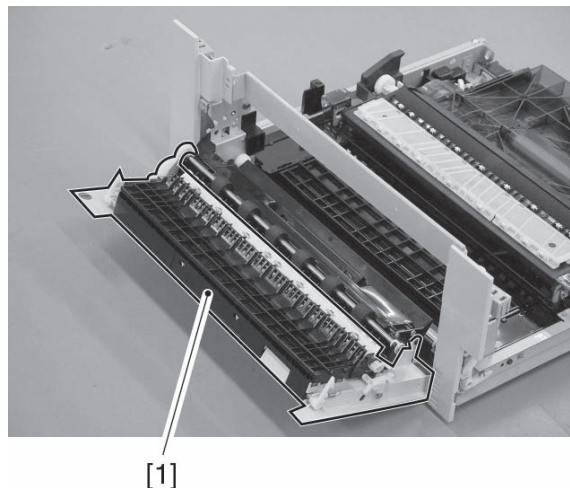

F05-839-02

- 4) Remove the screw [1], and detach the duct [2].

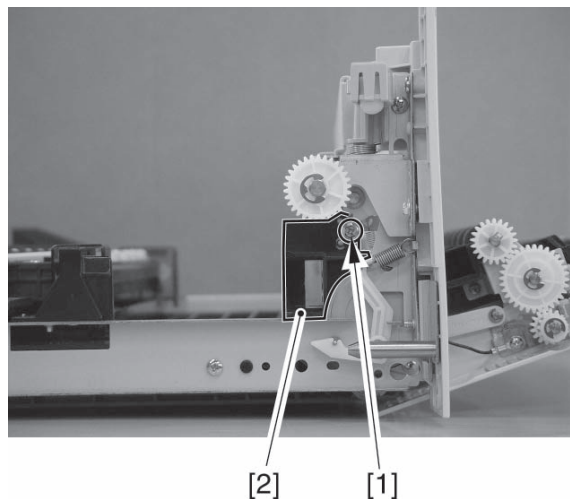

F05-839-03

- 5) Remove the screw [1] at the rear, and free the boss [A] and the hook [B]; then, detach the cover (rear) [2].

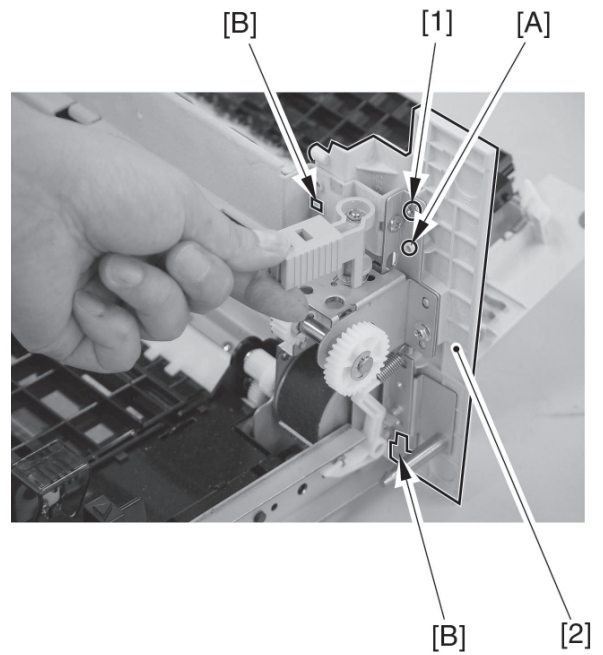

F05-839-04

- 6) Remove the 2 screws [1], and shift the duplex feeder motor [2] in the direction indicated to detach.

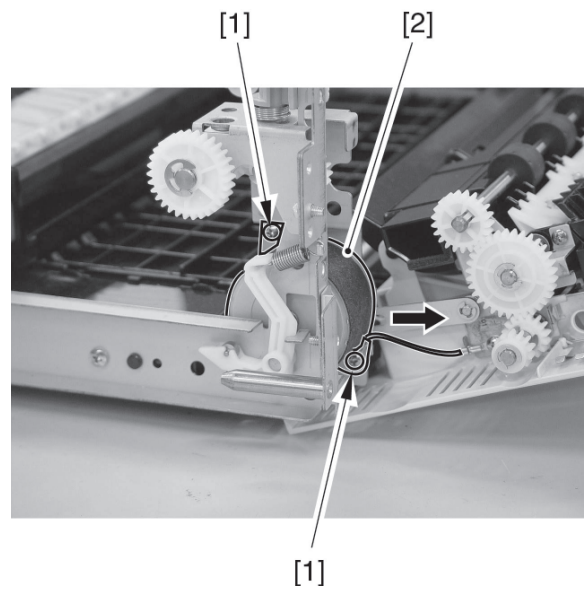

F05-839-05



Points to Note When Mounting the Duplex Feeder Motor

1. Be sure that the connector area is at the bottom.
2. Be sure to tighten the lower right screw [1] together with the grounding wire [2].

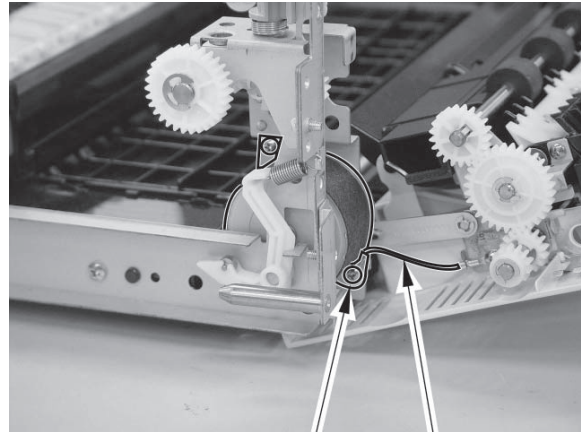

[1] [2]

F05-839-06

8.40 Removing the Duplex Registration Sensor

- 1) Remove the fixing feeder unit. (See 8.14 'Removing the Fixing Feeder Unit.')
- 2) Remove the sheet from behind the fixing feeder assembly. (See 8.34 'Removing the Horizontal Registration Motor.')
- 3) Disconnect the connector [1], free the 2 claws [2], and remove the sensor base [3]; then, detach the duplex registration sensor [4].

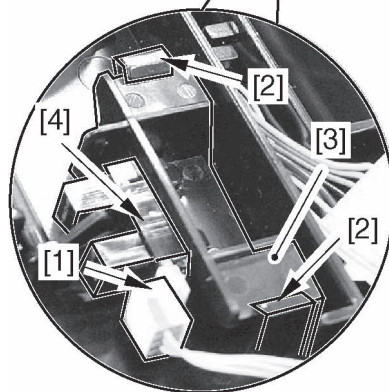
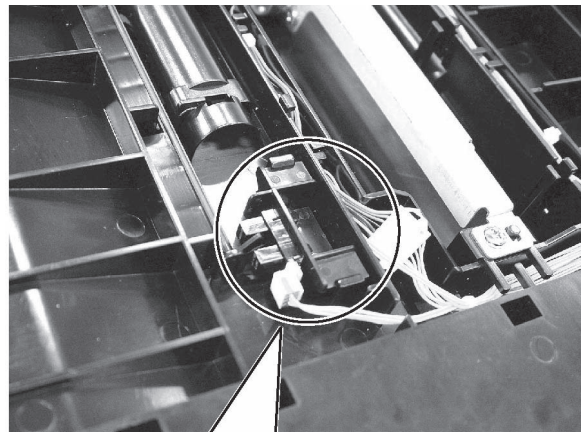

F05-840-01

8.41 Removing the Duplex Pickup Sensor

- 1) Slide out the fixing/feeder unit. (See 8.14 'Removing the Fixing Feeder Unit.')
- 2) Remove the front cover.
- 3) Remove the cleaner fan cover.
- 4) Remove the transfer unit releasing lever.
- 5) Remove the inside cover [lower].
- 6) Slide out the cassette 1.
- 7) Remove the manual feed unit. (See 8.44 'Removing the Manual Feed Unit.')
- 8) Remove the pickup unit 1. (See 8.1 'Removing the Pickup Unit.')
- 9) Remove the rear cover (upper, lower).
- 10) Remove the high-voltage unit. (See 5.2 'Removing the High-Voltage Unit.')
- 11) Remove the manual feed fan duct. (See 5.17 'Removing the Manual Feed Cooling Fan.' in Chapter 7.)
- 12) Remove the duplex driver PCB unit. (See 5.27 'Removing the Duplex Driver PCB' in Chapter 7.)
- 13) Remove the 2 screws [1] from the rear side plate side, and detach the rail support plate [2] of the manual feed unit.

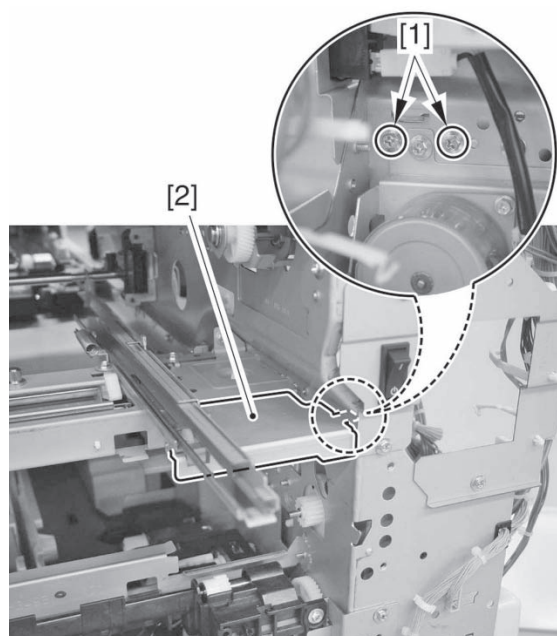

F05-841-01

- 14) Remove the 3 screws [1] from the side of the rear side plate and the 2 screws [2] from the side of the front side plate; then, detach the rail guide [3] of the manual feed unit as shown.

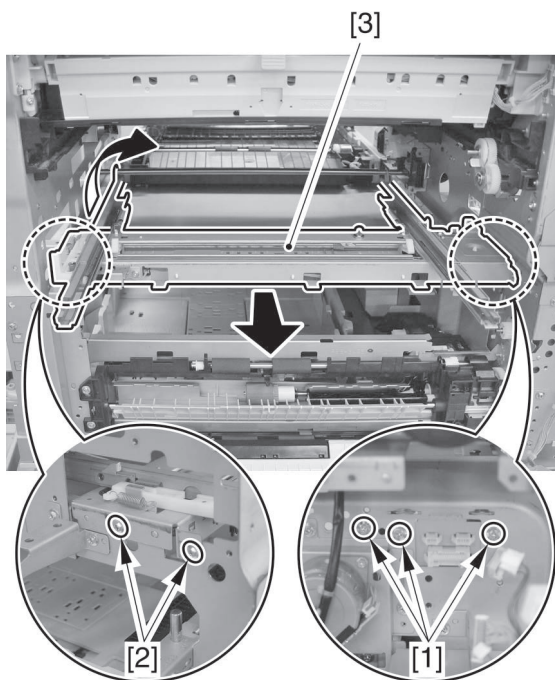

F05-841-02

- 15) Remove the 2 screws [1], and detach the drawer connector support plate [2].

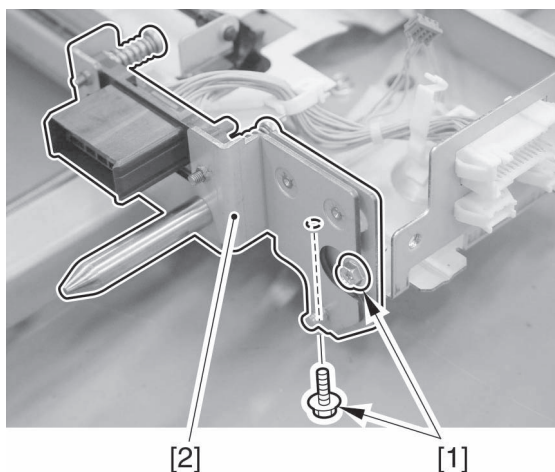

F05-841-03

16) Remove the 2 screws [1], and detach the lower guide plate [2].

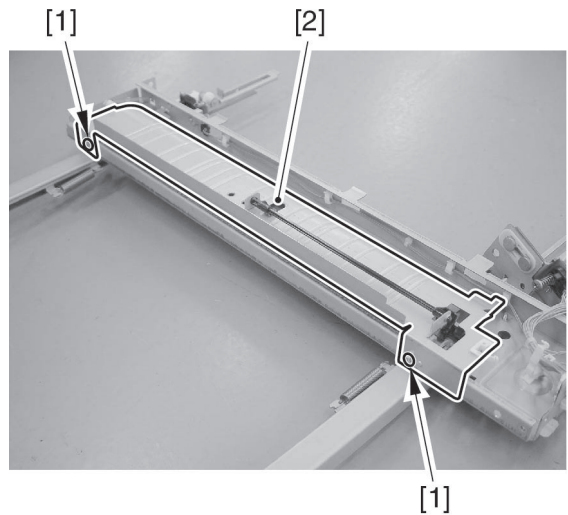

F05-841-04

17) Disconnect the connector [1], and remove the screw [2]; then, detach the sensor support plate [3].

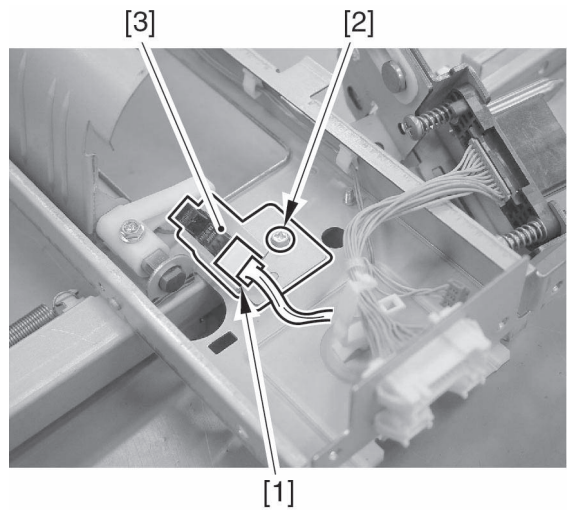

F05-841-05

18) Remove the duplex pickup sensor [1].

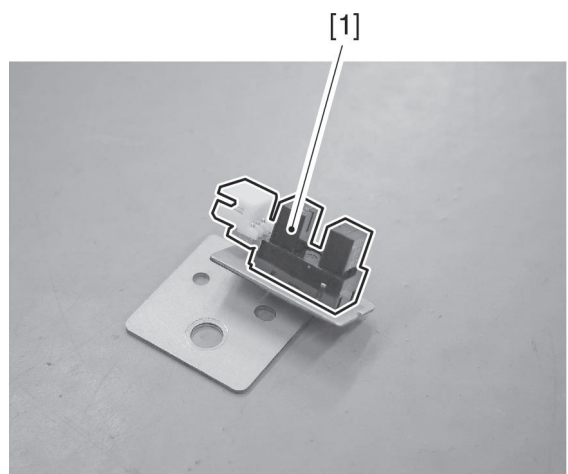

F05-841-06

8.42 Removing the Duplex Roller 1

- 1) Remove the fixing feeder unit. (See 8.14 'Removing the Fixing Feeder Unit.')
- 2) Open the fixing feeder unit cover.
- 3) Remove the fixing feeder unit rear cover.
- 4) Remove the duct.
- 5)



When removing the gear, pay attention not to lose the parallel pin found at the rear.

Remove the 2 E-rings [1], gear [2], and link [3]; then, remove the screw [4] to detach the grounding wire [5].

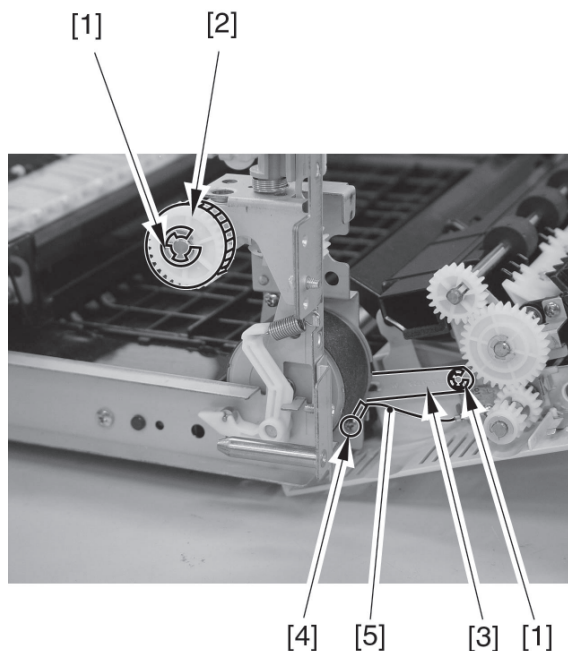

F05-842-01

- 7) Remove the 2 screws [1], and detach the motor base [2].

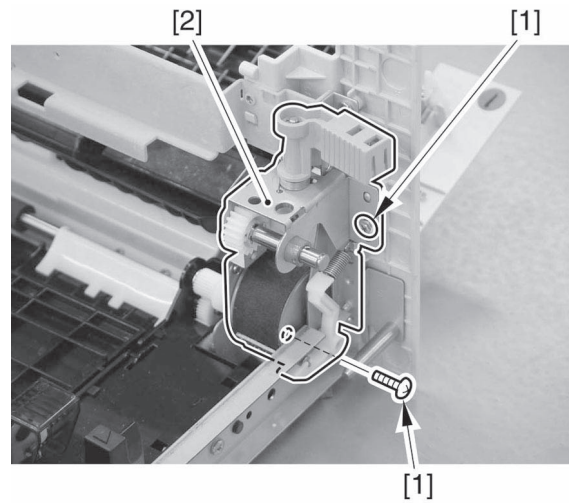

F05-842-02

- 8) Remove the gear [1] and the bearing [2] at the rear.

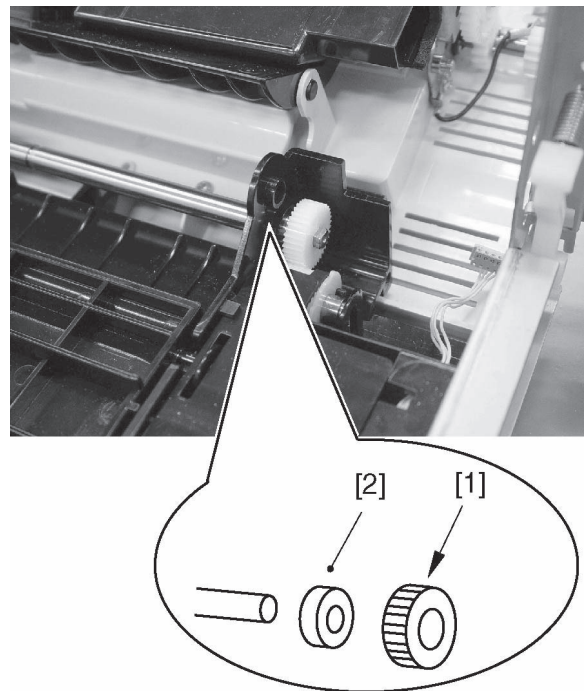

F05-842-03

- 9) Remove the 2 duplex auxiliary guides [1] of the duplex roller.

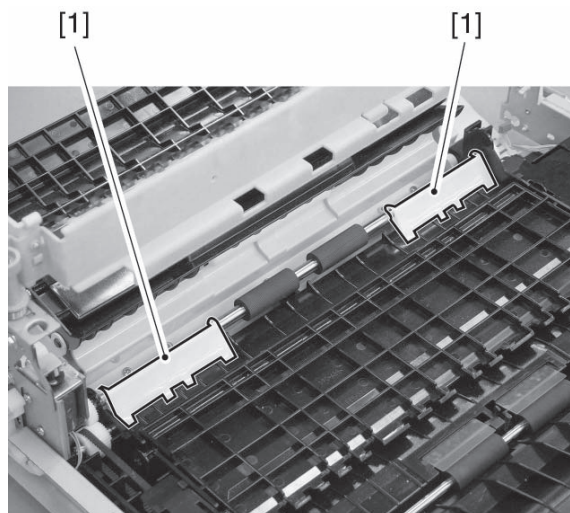

F05-842-04

- 10) Remove the screw [1], and disconnect the connector [2]; then, detach the delivery path switching solenoid 2 [3] together with the base.

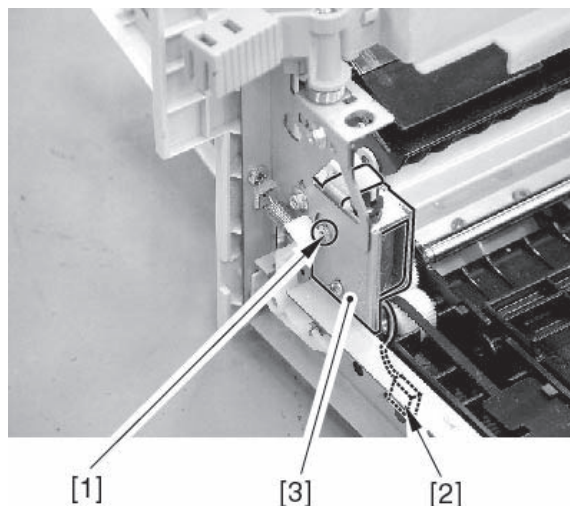

F05-842-05

- 11) Free the claw of the gear [1] at the front; then, slide the roller to the rear, and remove the gear [1] and the bearing [2].

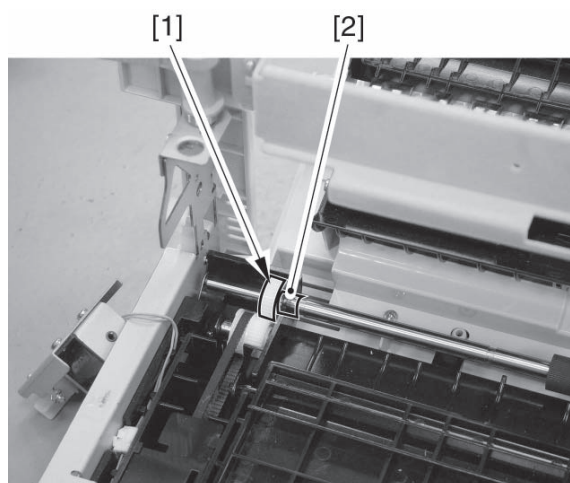

F05-842-06

12) Remove the duplexing roller [1].

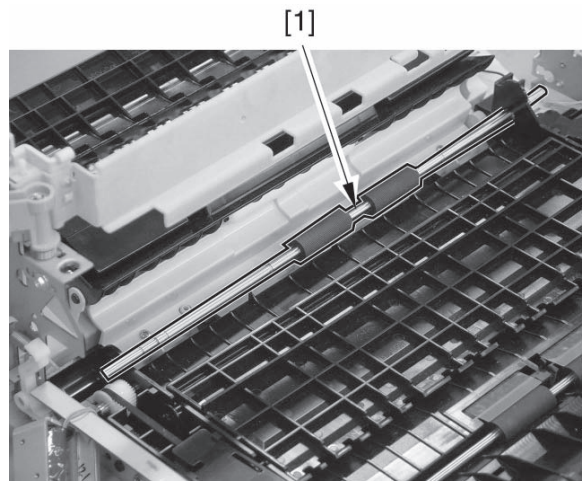

F05-842-07



Points to Note When Mounting

1. Be sure that the longer side [A] of the D-cut in the roller shaft [1] is toward the front.

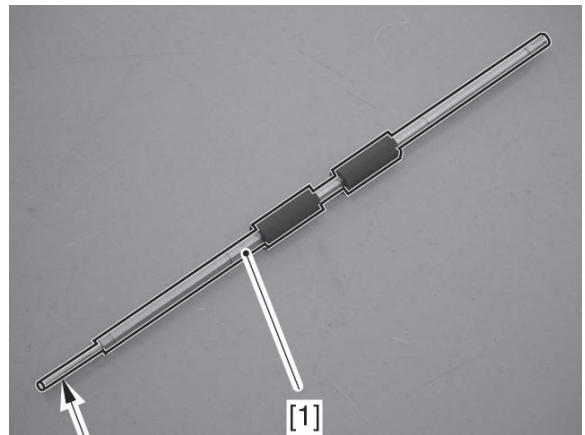

F05-842-08



Points to Note When Mounting
When mounting, be sure that the front tip of the roller shaft is in contact with the grounding plate [A].

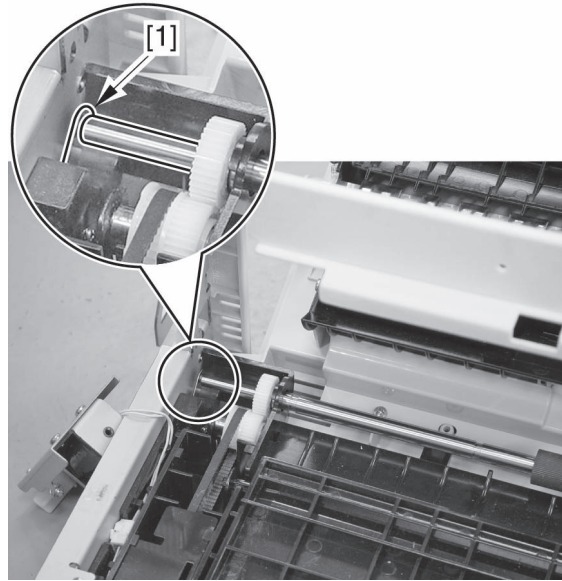

F05-842-09

8.43 Removing the Internal Delivery Roller

- 1) Slide out the fixing feeder unit.
- 2) Open the fixing feeder unit cover.
- 3) Remove the E-ring and the bushing [2] at the front; then, remove the gear [3] and the bushing [4] at the rear.

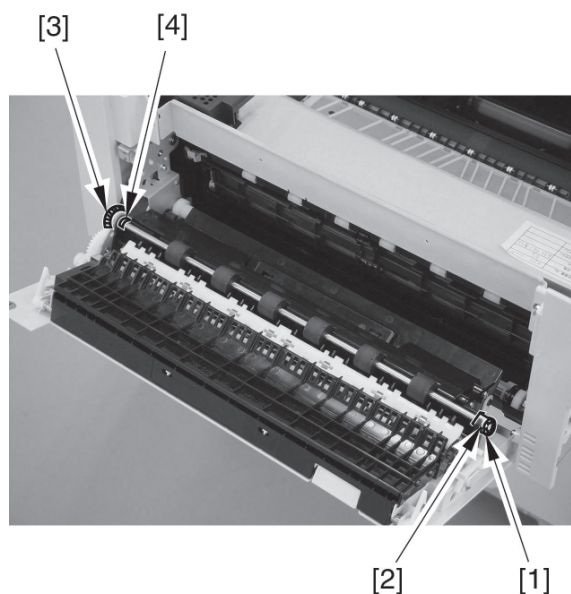

F05-843-01

- 4) Free the internal delivery roller [1] from the cut-off of the frame at the front; then, detach it.

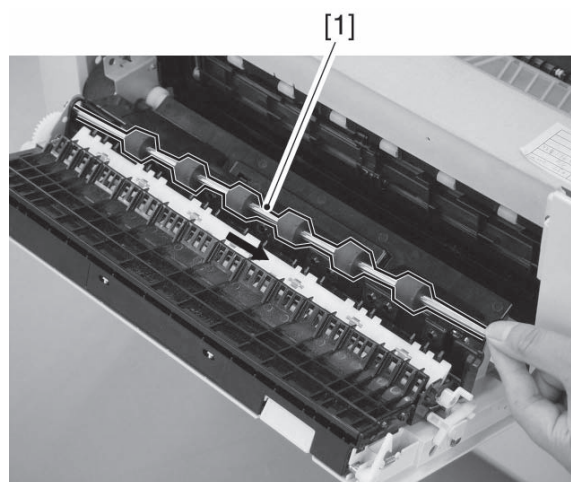

F05-843-02

8.44 Removing the Manual Feed Unit

- 1) Press the release button [1] on the machine's right side to slide out the manual feed unit [2].

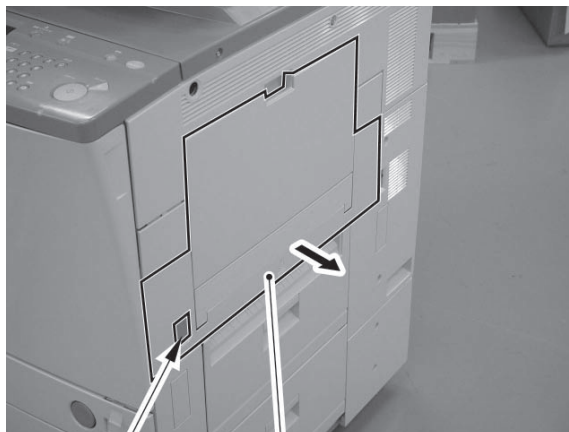

[1] [2]

F05-844-01

- 2) Remove the screw [1] and the stopper plate [2]; then, detach the manual feed unit [3].

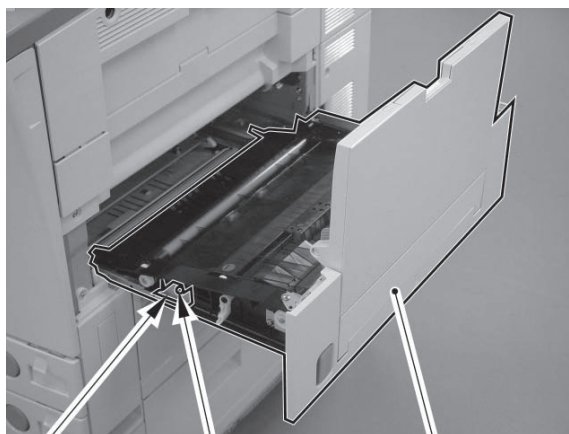

[2] [1] [3]

F05-844-02

8.45 Removing the Manual Feed Tray Unit

- 1) Slide out the manual feed unit. (See 8.44 'Removing the Manual Feed Unit.')
- 2) Remove the screw [1], and free the 3 claws [2] and the 3 snap-ons [3]; then, detach the manual feed unit cover [4].

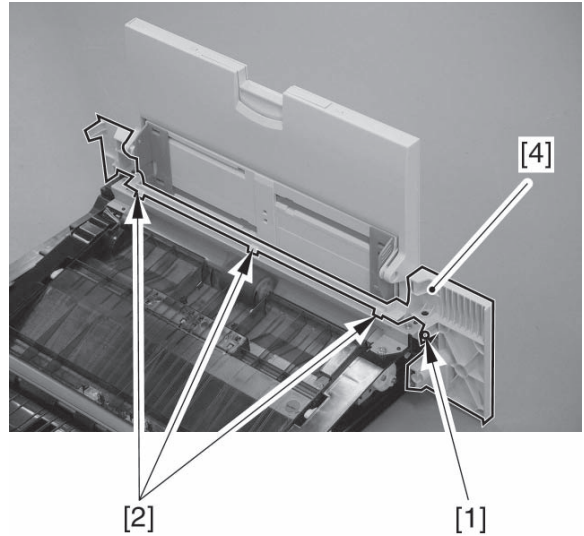

F05-845-01

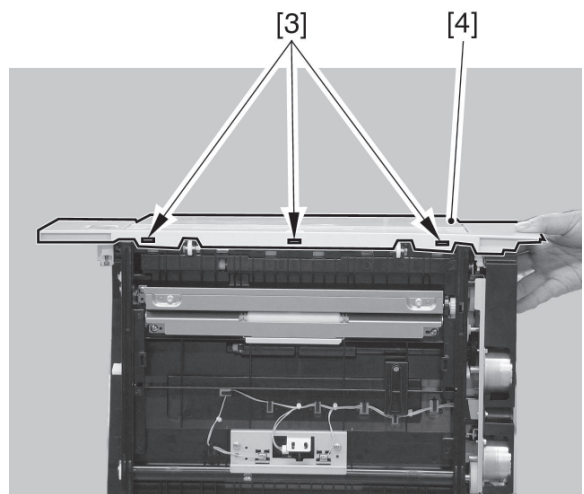

F05-845-02

- 3) Remove the 3 screws [1], and detach the base [2].

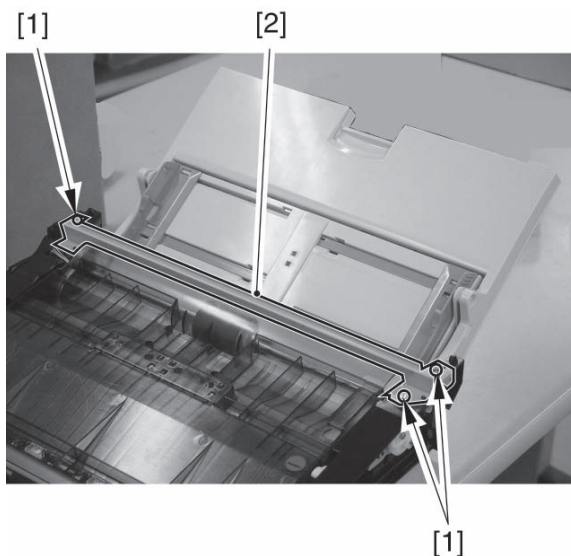

F05-845-03

- 4) Disconnect the connector [1] at the rear; then, while opening the face plate [2], shift the manual feed tray [3] 90° or more to detach it upward.

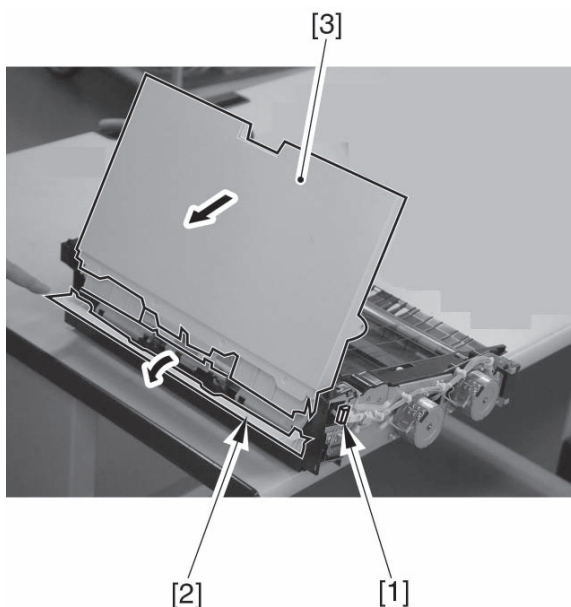

F05-845-04

8.46 Removing the Transparency Sensor (front/rear)



Both front and rear transparency sensors may be removed in the same way.

- 1) Remove the manual feed unit. (See 8.44 ‘Removing the Manual Feed Unit.’)
- 2) Disconnect the 3 connectors [1], and remove the 2 screws [2]; then, detach the sensor base [3] found at the bottom.

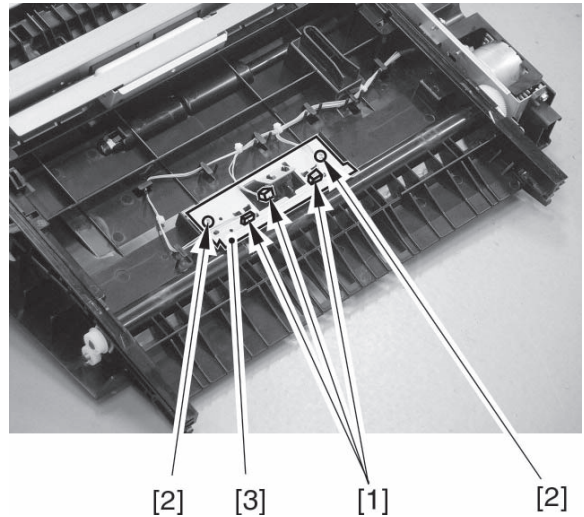

F05-846-01

- 3) While taking care not to touch the light-emitting face, detach the transparency sensor [1].

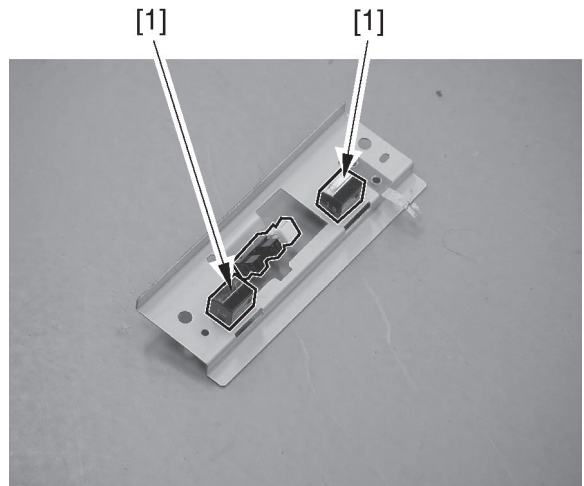

F05-846-02

8.47 Removing the Registration Sensor

- 1) Remove the manual feed unit. (See 8.44 ‘Removing the Manual Feed Unit.’)
- 2) Disconnect the 3 connectors [1], and remove the 2 screws [2]; then, detach the sensor base [3] from the bottom.

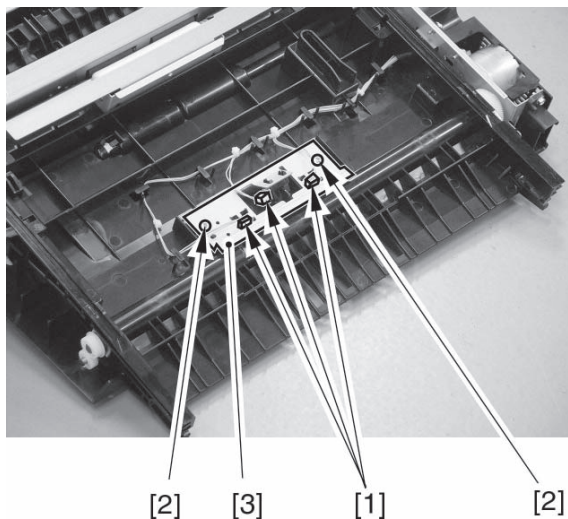

F05-847-01

- 3) While taking care not to touch the light-emitting face of the transparency sensor [1], detach the registration sensor [2].

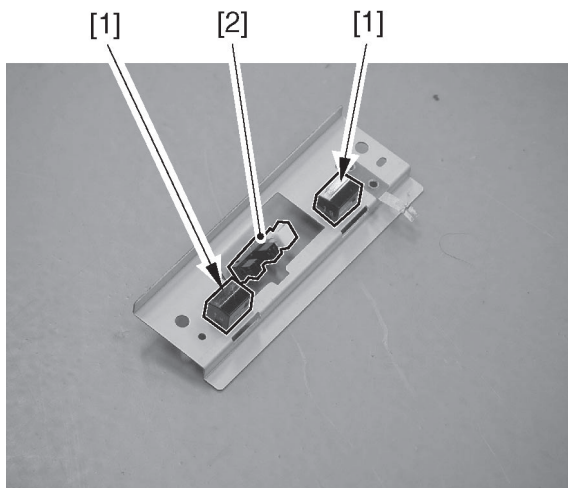

F05-847-02

8.48 Removing the Manual Feed Roller

- 1) Remove the manual feed unit. (See 8.44 'Removing the Manual Feed Unit.')
- 2) Remove the manual feed unit cover.
(See 8.45 'Removing the Manual Feed Tray Unit.')
- 3) Remove the 3 screws [1], and detach the mounting plate [2].

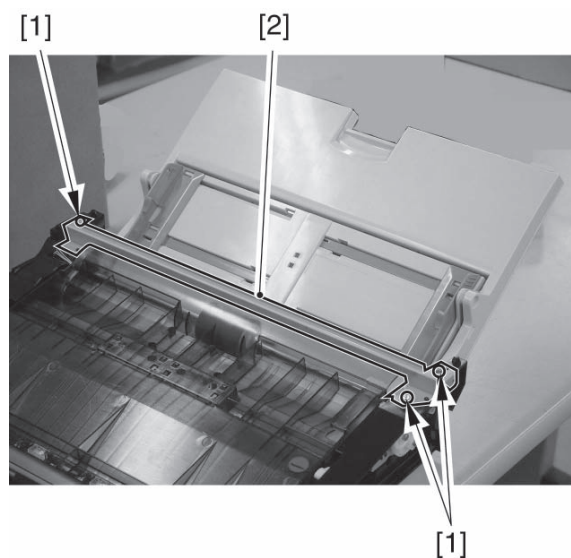

F05-848-01

- 4) Remove the gear [1] at the front, and detach the bushing [2]. (For both gear and the bushing, free the claw fitted in the groove of the roller for detachment.)

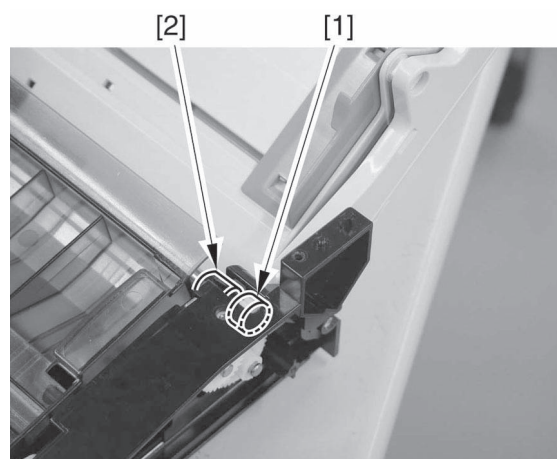

F05-848-02

5) Remove the bushing [1] at the rear.

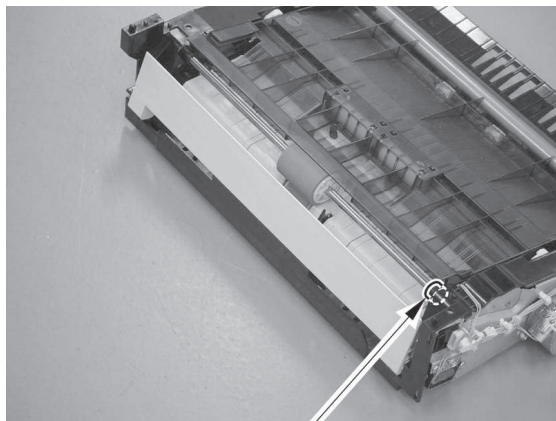

[1]

F05-848-03

6) Remove the resin clamp [1], and pull out the manual feed roller [2].



When attaching the manual feed roller, be sure that the groove of the parallel pin is toward the rear.

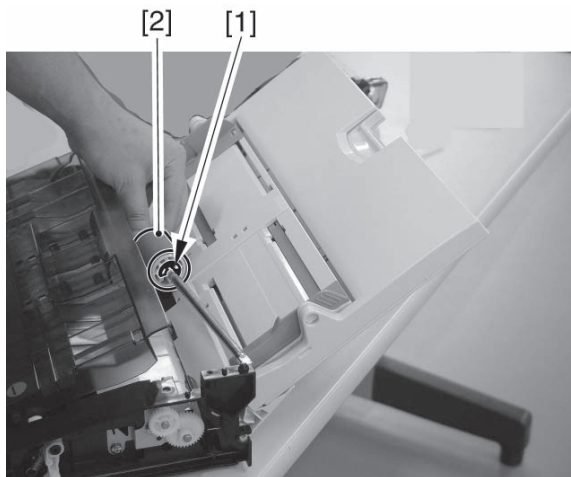

F05-848-04



When attaching the bushing and the gear at the front, check to be sure that the claw is hooked on the groove of the roller.

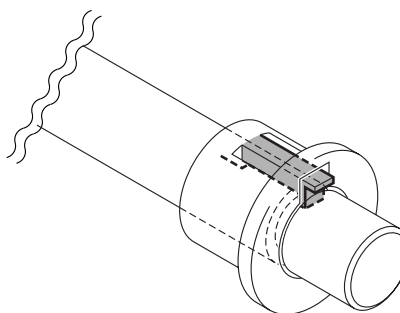
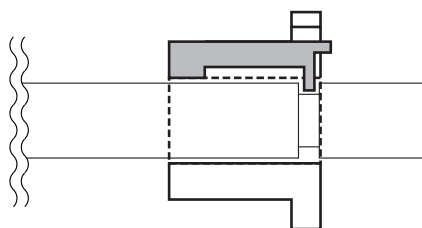

F05-848-05

8.49 Removing the Manual Feed Separation Roller

- 1) Remove the manual feed unit. (See 8.44 'Removing the Manual Feed Unit.')
- 2) Remove the manual feed unit cover.
(See 8.45 'Removing the Manual Feed Tray Unit.')
- 3) Remove the screw [1], and detach the motor cover [2] at the rear.

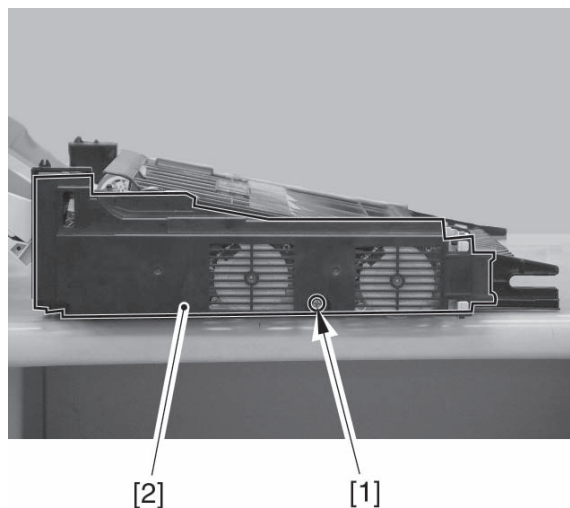

F05-849-01

4)



When removing the face plate,
pay attention not to lose the
spring at the front.

Pull out the face plate [1].

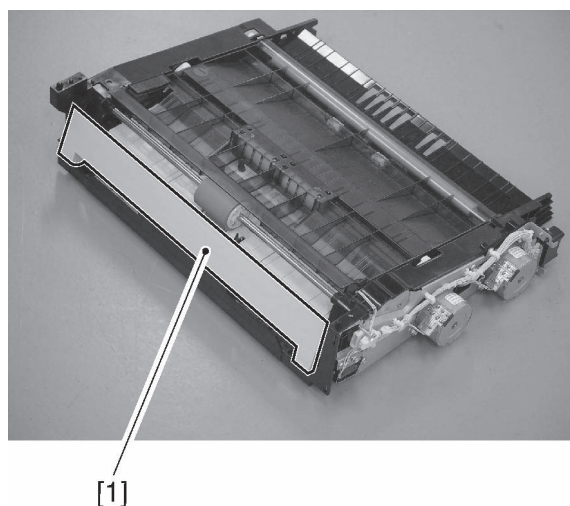

F05-849-02



When attaching, be sure that the spring [2] fits into the hole [1] at the front of the frame.

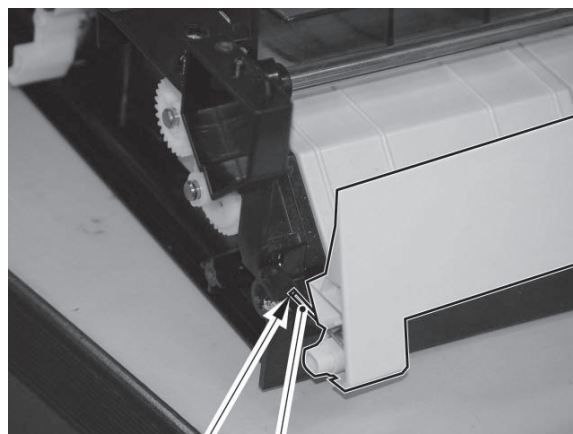

[1] [2]

F05-849-03

- 5) Remove the manual feed roller. (See 8.48 'Removing the Manual Feed Roller.')
- 6) Remove the rear guide [1] and the middle guide [2]. (Release the snap-on claw.)

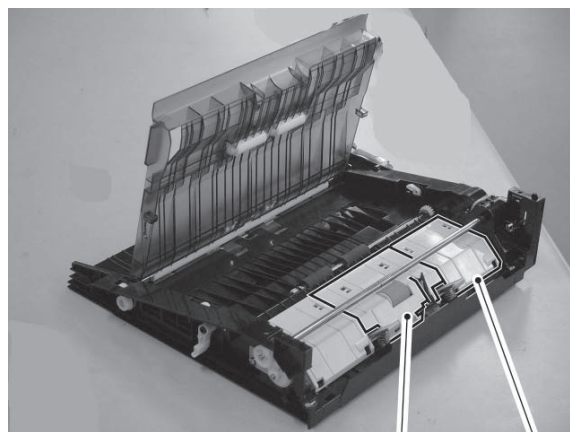

[2] [1]

F05-849-04

- 7) Pick up the tab of the manual feed separation roller [1], and pull it out in the direction of the arrow.

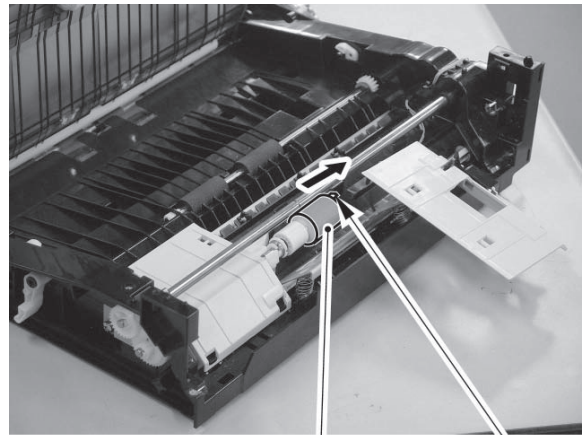

[1]

[A]

F05-849-05

8.50 Removing the Manual Feed Paper Sensor

- 1) Remove the manual feed unit. (See 8.44 'Removing the Manual Feed Unit.')
- 2) Remove the manual feed unit cover. (See 8.45 'Removing the Manual Feed Tray Unit.')
- 3) Remove the manual feed roller. (See 8.48 'Removing the Manual Feed Roller.')
- 4) Remove the manual feed separation roller. (See 8.49 'Removing the Manual Feed Separation Roller.')
- 5) Remove the rear guide and the middle guide. (See 8.49 'Removing the Manual Feed Separation Roller.')
- 6) Remove the sensor flag [2] attached to the middle guide [1].

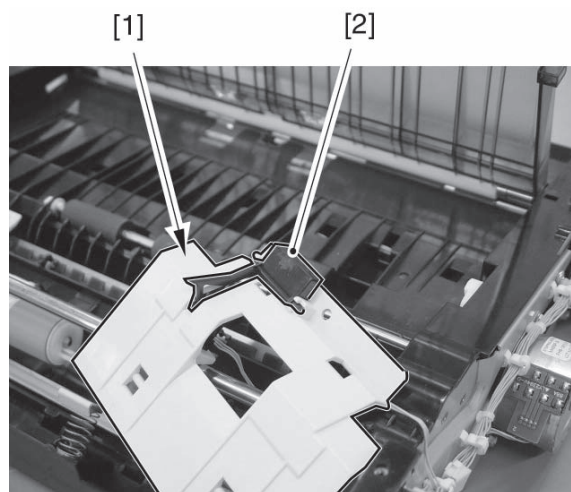

F05-850-01

- 7) Disconnect the connector [1] from behind the middle guide, and detach the manual feed paper sensor [2].

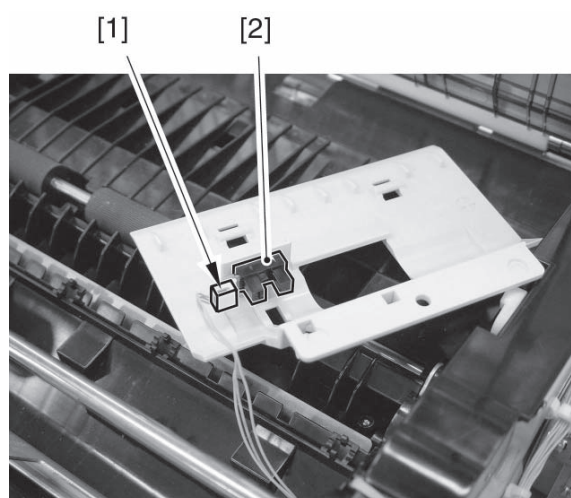

F05-850-02

8.51 Removing the Manual Feed Pickup Solenoid

- 1) Remove the manual feed unit. (See 8.44 'Removing the Manual Feed Unit.')
- 2) Remove the manual feed unit cover. (See 8.48 'Removing the Manual Feed Roller.')
- 3) Remove the motor cover. (See 8.49 'Removing the Manual Feed Separation Roller.')
- 4) Disconnect the connector [1], and remove the screw [2]; then, detach the manual feed pickup solenoid [3].

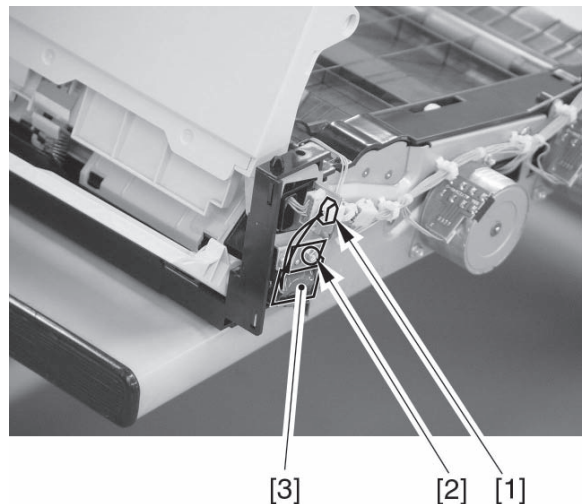

F05-851-01



Points to Note When Attaching the Manual Feed Pickup Solenoid

When attaching the solenoid [1], be sure to hook the flapper [A] on the claw [B] of the gear [2].

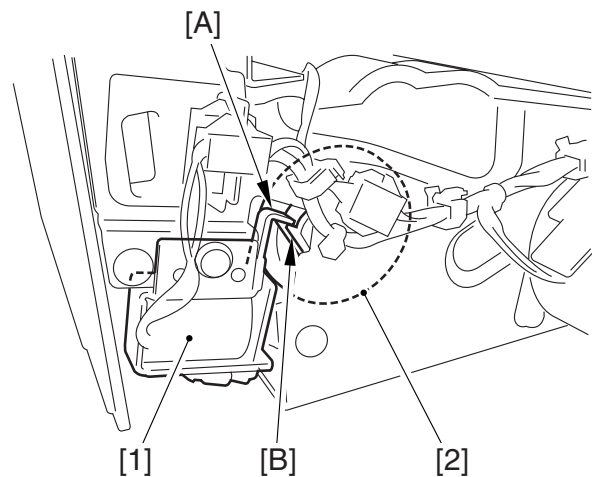

F05-851-02

8.52 Removing the Pre-Registration Motor

- 1) Remove the manual feed unit.
- 2) Remove the manual feed cover. (See 8.48 'Removing the Manual Feed Roller.')
- 3) Remove the motor cover. (See 8.50 'Removing the Manual Feed Paper Sensor.')
- 4) Disconnect the connector [1], and remove the 2 screws [2]; then, detach the pre-registration motor [3].

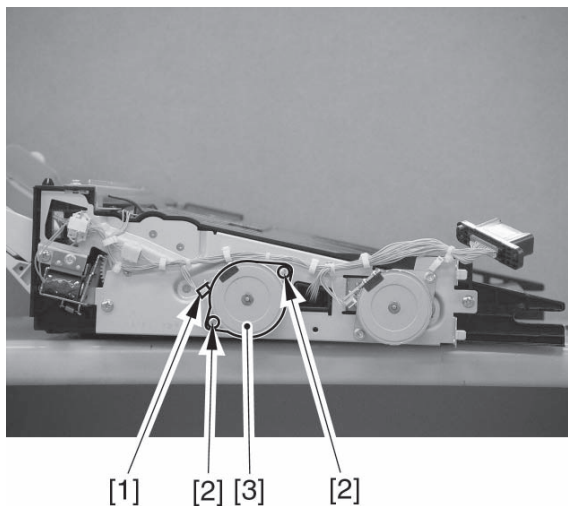

F05-852-01

8.53 Removing the Registration Motor

- 1) Remove the manual feed unit.
- 2) Remove the manual feed unit cover.
(See 8.48 'Removing the Manual Feed Roller.')
- 3) Remove the motor cover. (See 8.50 'Removing the Manual Feed Paper Sensor.')
- 4) Disconnect the connector [1], and remove the 2 screws [2]; then, detach the registration motor [3].

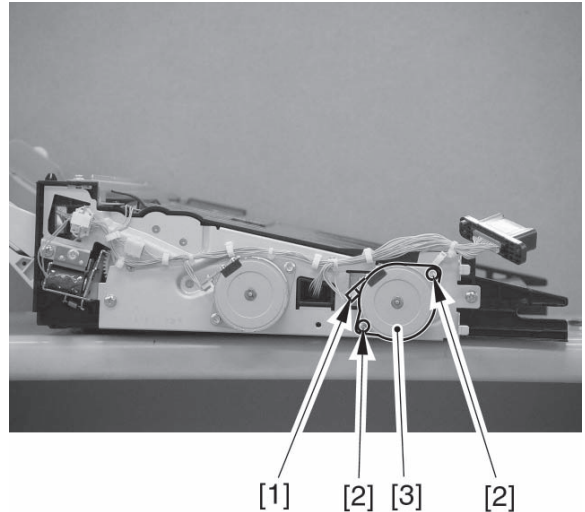

F05-853-01

8.54 Removing the Slide Resistor

- 1) Remove the manual feed unit. (See 8.44 ‘Removing the Manual Feed Unit.’)
- 2) Remove the manual feed tray unit. (See 8.45 ‘Removing the Manual Feed Tray Unit.’)
- 3) Spread the side guide [1] of the manual feed tray unit, and separate it into the upper cover [2] and the lower cover [3] (for detachment).

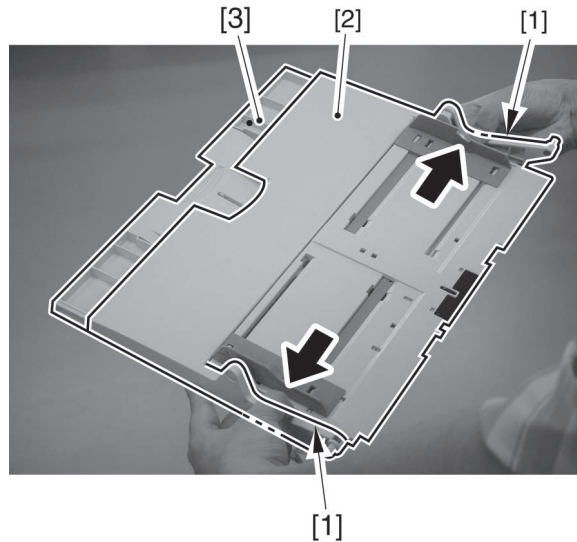

F05-854-01



When attaching the upper cover [1] and the lower cover [2], match the markings [A] found on the side, and slide them into place.

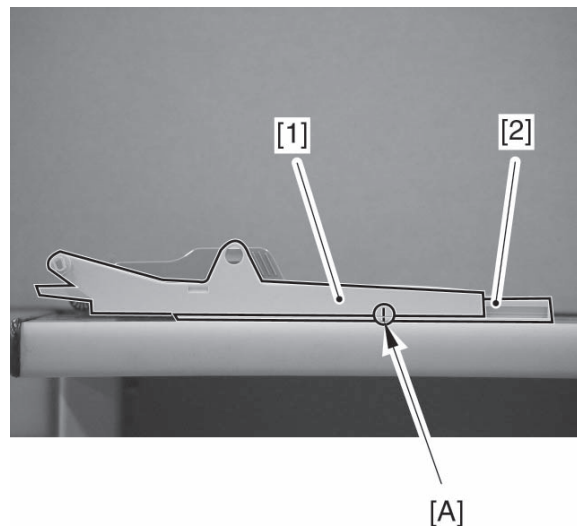

F05-854-02

4)



1. When detaching the slide resistor, do not apply excess force when spreading the claw of the lower cover; otherwise, the claw can break.
2. When attaching the slide resistor, take care not to touch the connector [1] at the edge of the slide resistor. Try to match the black protrusion [A] behind the slide resistor against the hole [A] in the tray.

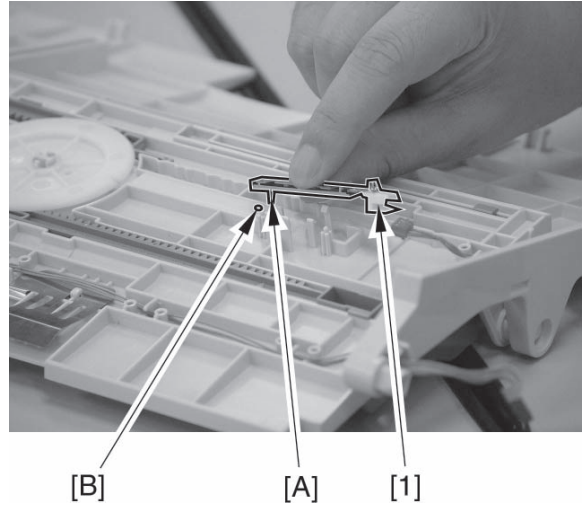

F05-854-03

Disconnect the connector [1] on the lower cover side, spread the claw [A], and detach the slide resistor [2].

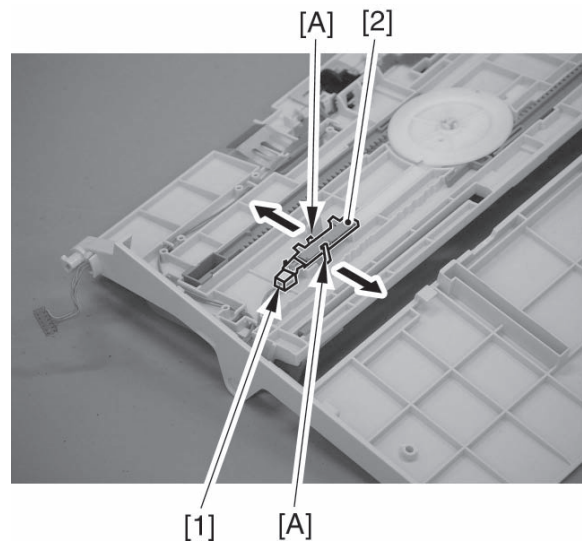

F05-854-04

8.55 Removing the Manual Feed Last Paper Sensor

- 1) Remove the manual feed unit. (See 8.44 'Removing the Manual Feed Unit.')
- 2) Remove the manual feed tray unit. (See 8.45 'Removing the Manual Feed Tray Unit.')
- 3) Remove the tray upper cover and lower cover. (See 8.54 'Removing the Slide Resistor.')



When attaching the upper cover and the lower cover, be sure to match the markings found on the side and slide them into place. (See 8.54 'Removing the Slide Resistor.')

- 4) Free the needle spring [1] from the hook, and detach the detecting roll [2].

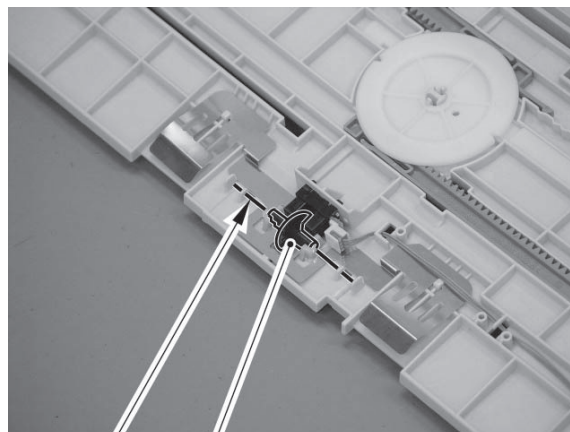

[1]

[2]

F05-855-01

- 5) Disconnect the connector [1], and detach the manual feed last paper sensor [2].

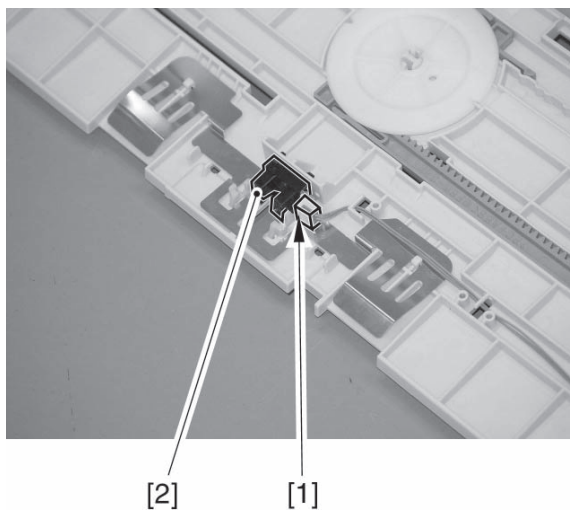

F05-855-02

8.56 Removing the Drawer Connector (fixing feeder unit)

- 1) Remove the fixing feeder unit. (See 8.14 'Removing the Fixing Feeder Unit.')
- 2) Free the harness [2] from the cable clamp [1], and disconnect the 2 connectors [3], and remove the 2 screws [4]; then, detach the connector base [5].

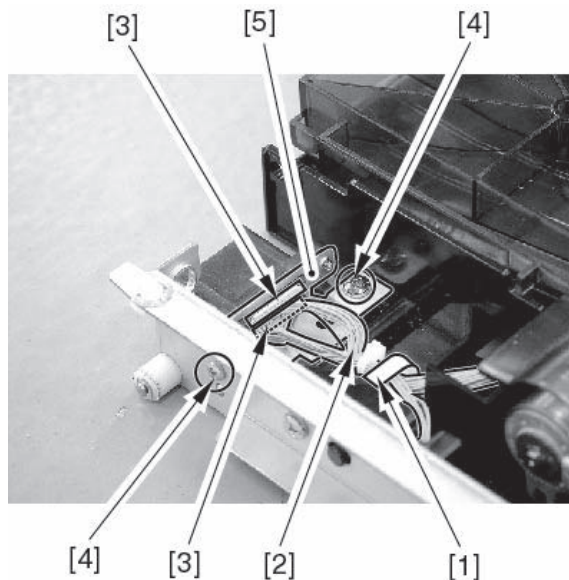

F05-856-01

- 3) Remove the 2 screws [1], and detach the drawer connector [2].

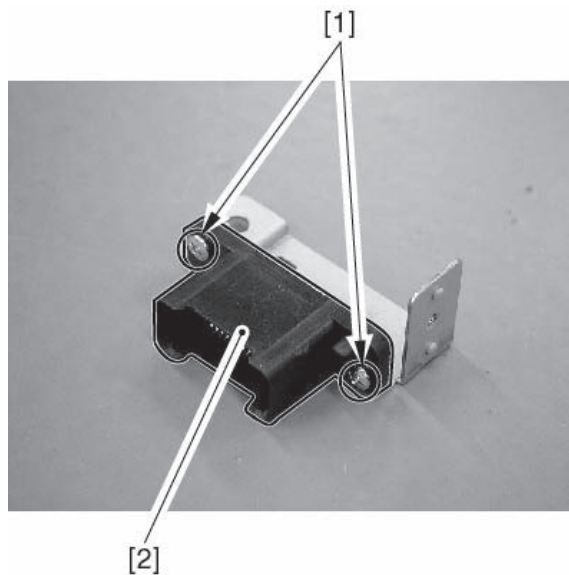

F05-856-01

8.57 Disconnecting the Drawer Connector (manual feed unit)

- 1) Remove the manual feed unit. (See 8.44 'Removing the Manual Feed Unit.')
- 2) Remove the 2 screws [1], and disconnect the drawer connector [2].

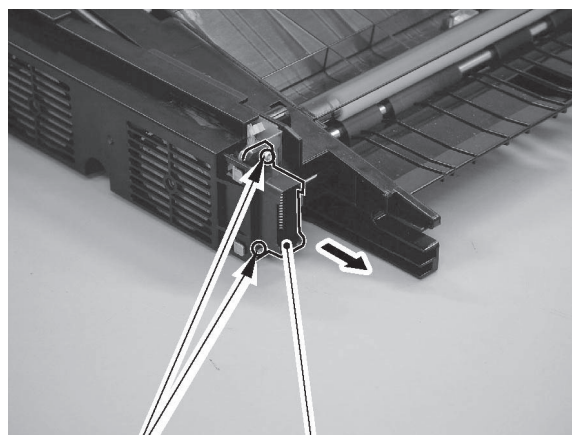

[1] [2]

F05-857-01

- 3) Disconnect the 2 connectors [1] from behind, and disconnect the drawer connector [2].

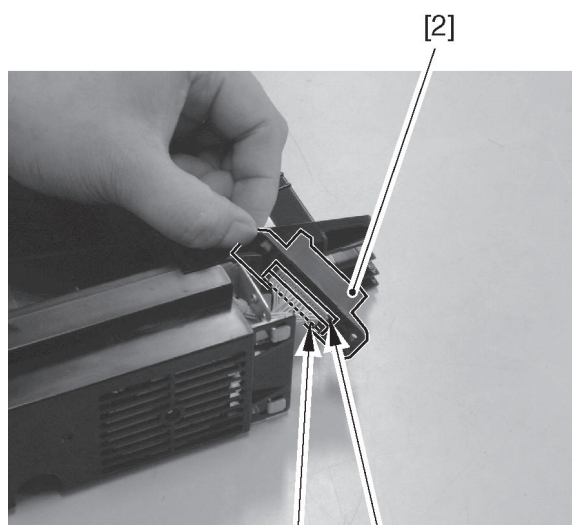

[1] [1] [2]

F05-857-02

8.58 Adjusting the Horizontal Registration When Replacing the Pickup Cassette

Make a test copy of the A3 Test Chart, and check to be sure that the margin on the front side of the image is correct ($L2 = 2.0 \pm 1.5$ mm); otherwise, go through the following steps to make adjustments, starting with the 1st side and then the 2nd side:

Adjusting the Horizontal Registration on the 1st Side

- 1) Slide out the manual feed unit and the cassette 1/2; then, open the pickup vertical path cover.
- 2) Remove the 2 screws [1], and detach the front right cover [2].

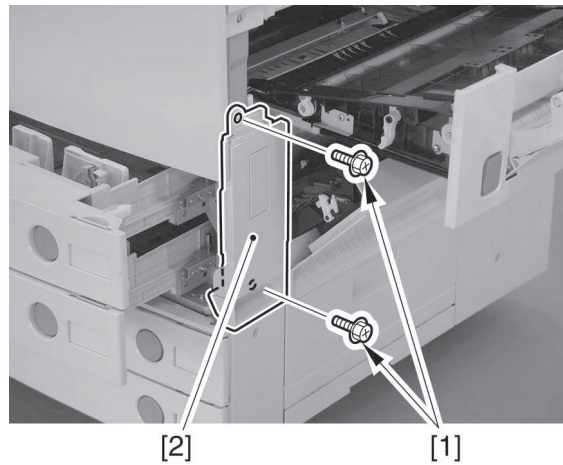

F05-858-01

• Adjusting the Cassette 1 Side

- 3) Insert a screwdriver through the hole in the front right stay, and loosen the screw [1] to adjust the position of the adjusting plate [2].

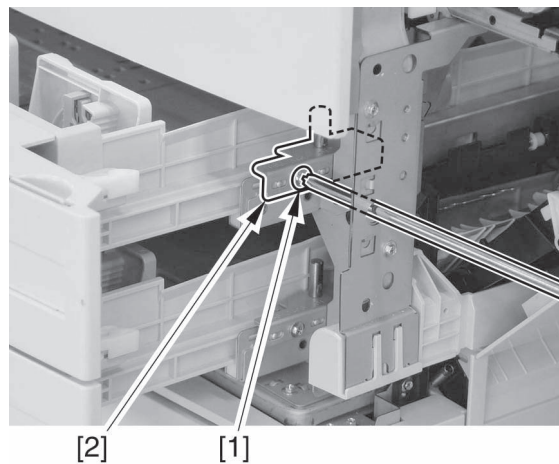

F05-858-02

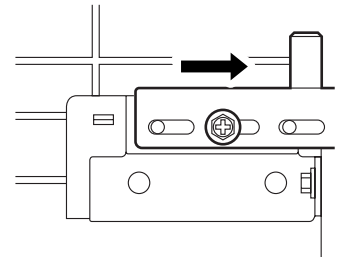

Moving the adjusting plate to the right

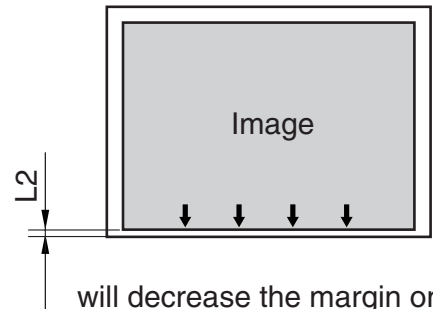

will decrease the margin on the front side of the paper.

F05-858-03

- Adjusting the Cassette 2 Side
- 3) Remove the grip [1] from the front right.

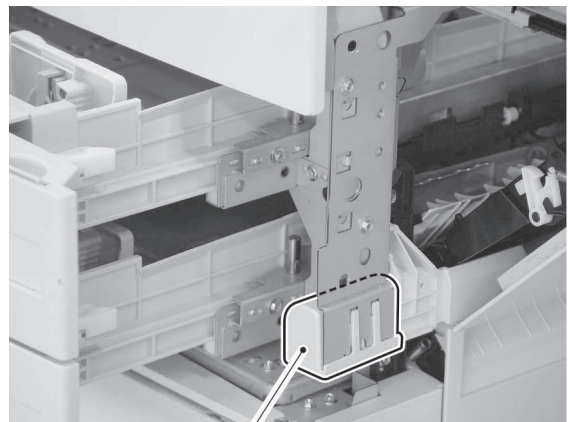

[1]

F05-858-04

- 4) Insert a screwdriver through the hole in the front right stay, and loosen the screw [1] to adjust the position of the adjusting plate [2].

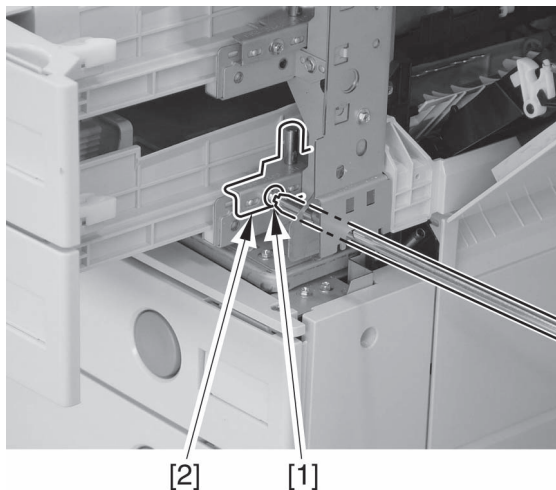

F05-858-05

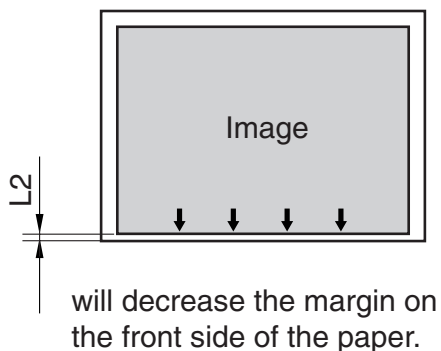
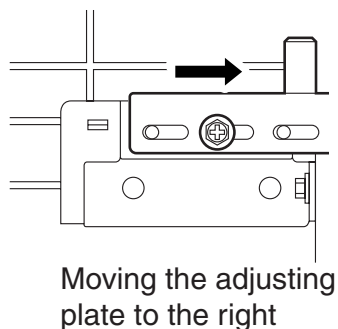

F05-858-06

Adjusting the Horizontal Registration on the 2nd Side
Use the following service mode to make adjustments:
COPIER>ADJUST>FEED-ADJ>ADJ-REFE

CHAPTER 6

FIXING

1 Outline of Operations

1.1 Specifications, Control Mechanisms, and Functions

The major functions of the fixing system are as follows:

Item	Description
Fixing method	Heat roller
Fixing heater	2 fixing rollers (main heater, sub heater) 1 pressure roller (heat retaining heater)
Control temperature	190°C (in PSTBY)
Fixing drive control	Fixing roller speed control (by paper type and mode)
Fixing temperature detection	Main thermistor (non-contact; TH1, center of fixing roller) Sub thermistor (TH2; rear end of fixing roller)
Protective mechanism	Error detection as follows; upon detection of error, cuts off power to fixing heater: <ul style="list-style-type: none"> • temperature detection by thermistor (TH1/TH2) • temperature control by fixing thermal switch (TP1; front end of fixing roller; operating temperature of 222 ±8°C)
Separation claw	Non-contact type (facilitates separation of paper in high-humidity environment; under normal conditions, separation by fixing/pressure roller)
Cleaning	None (cleaning-less mechanism; no element in paper path of fixing/pressure roller)

T06-101-01

1.2 Major Components

The fixing system consists of the following major components:

Component	Notation	Description
Fixing roller		48.5 mm (external diameter)
Pressure roller		38.0 mm (external diameter)
Main heater (halogen)	H1	100/120V: 500W 230V: 545W
Sub heater (halogen)	H2	100/120V: 330W 230V: 360W
Heat retaining heater (glass tube)	H3	100/120/230V:80W (no temperature control)
Main thermistor	TH1	Non-contact type (temperature control/overheating detection)
Sub thermistor	TH2	Temperature control, overheating detection
Thermal switch	TP1	222 ±8°C (operating temperature)
Separation claw		Non-contact type (facilitates paper separation in high-humidity environment)
Fixing inlet sensor	PS27	Detection of passage of paper to fixing unit
Fixing delivery sensor	PS25	Detection of delivery of paper after fixing

T06-102-01

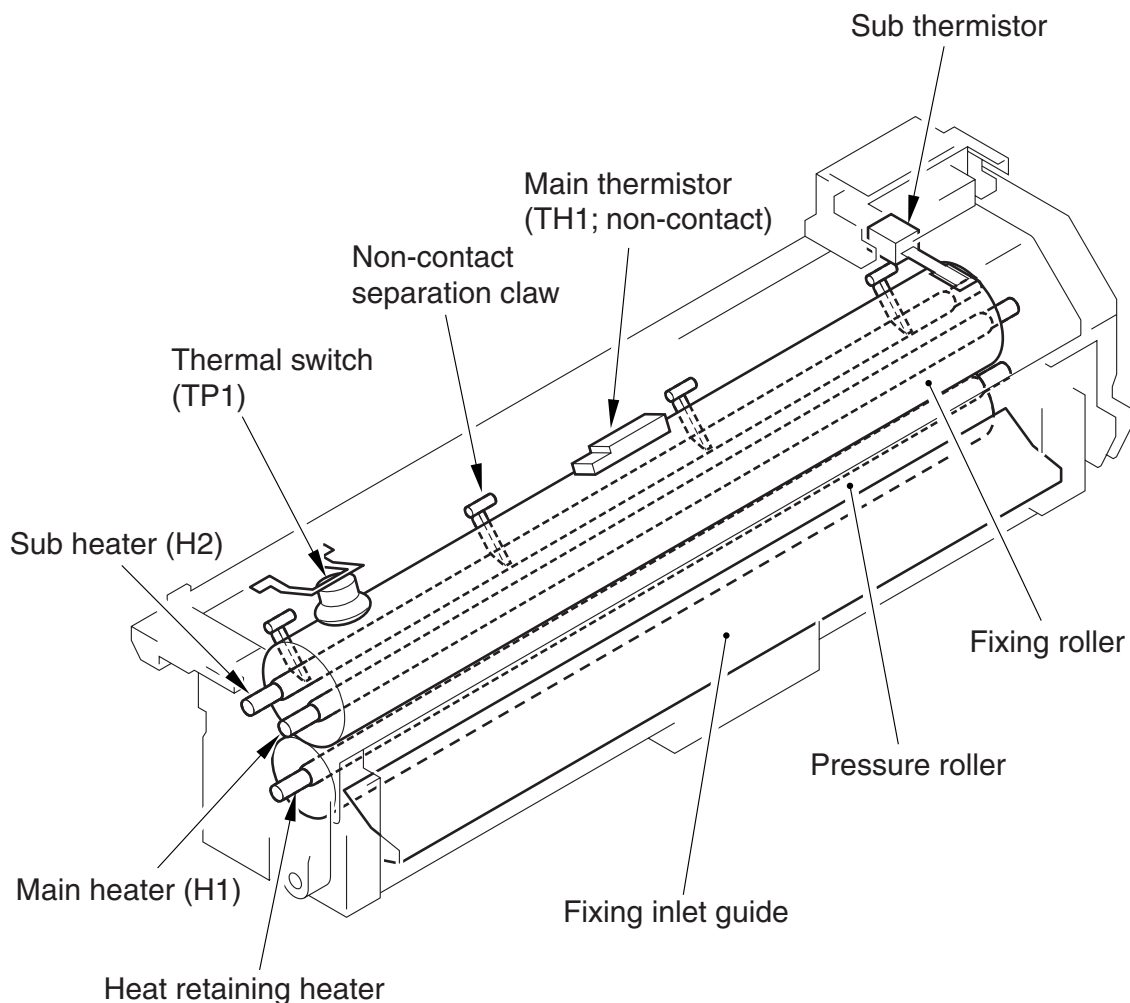

F06-102-01

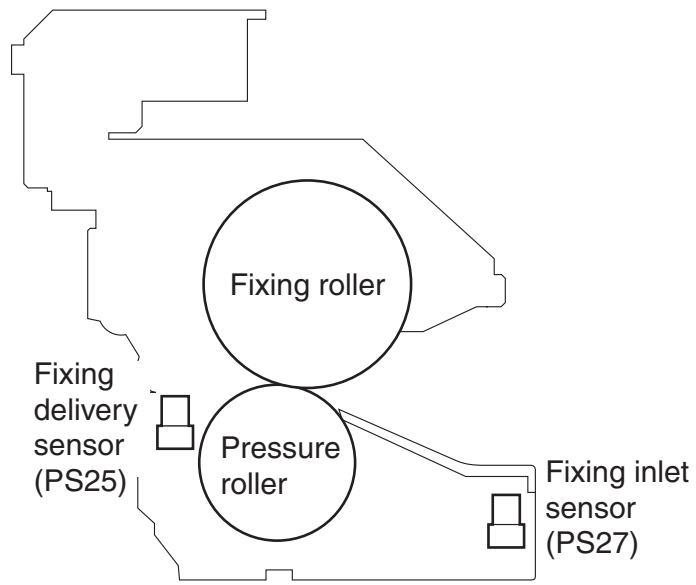

F06-102-02

1.3 Construction of the Control System

The major components of the fixing system are arranged as follows:

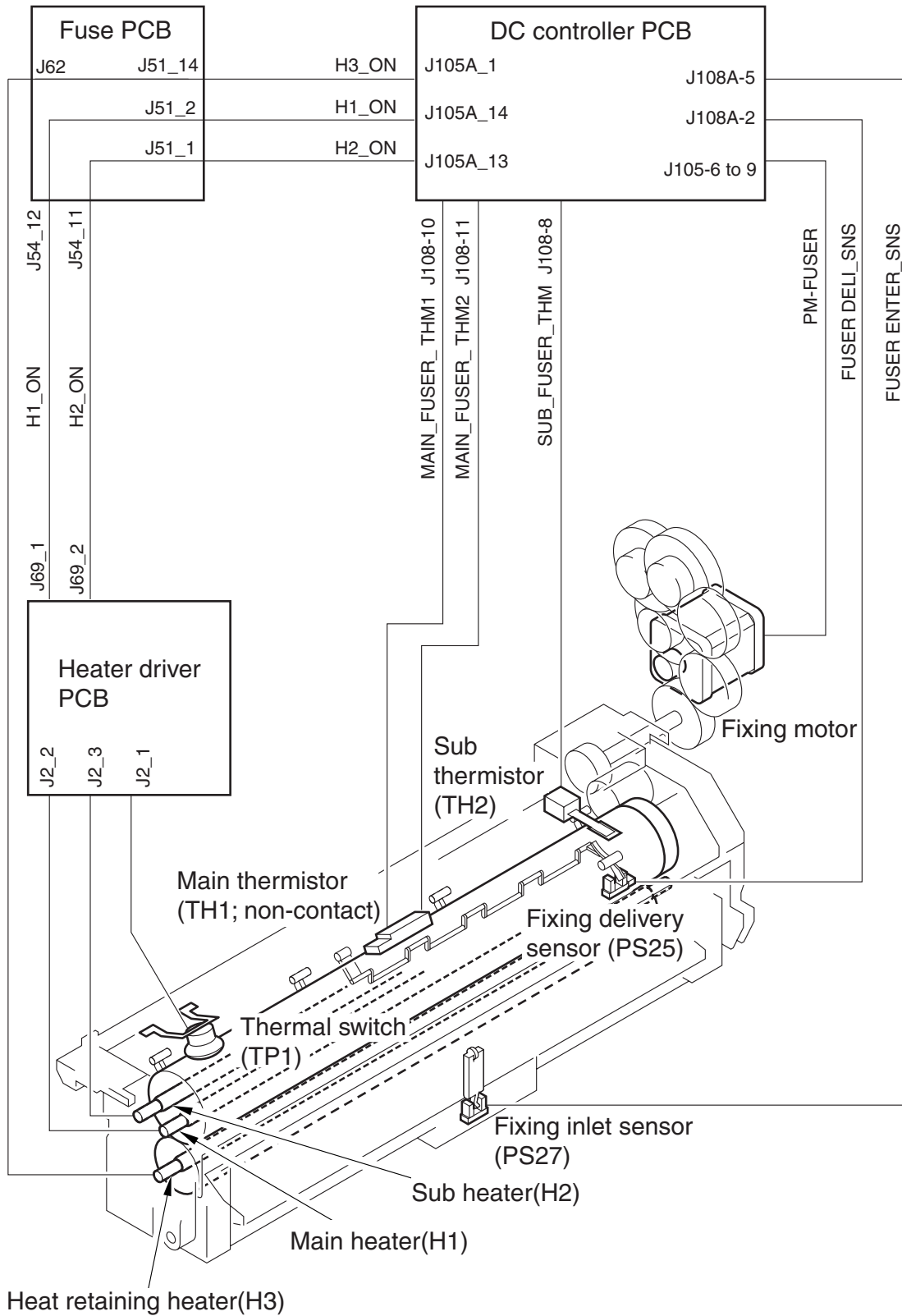

F06-103-01

1.4 Sequence of Operations (fixing system)

1.4.1 Sequence of Operations at Power-On

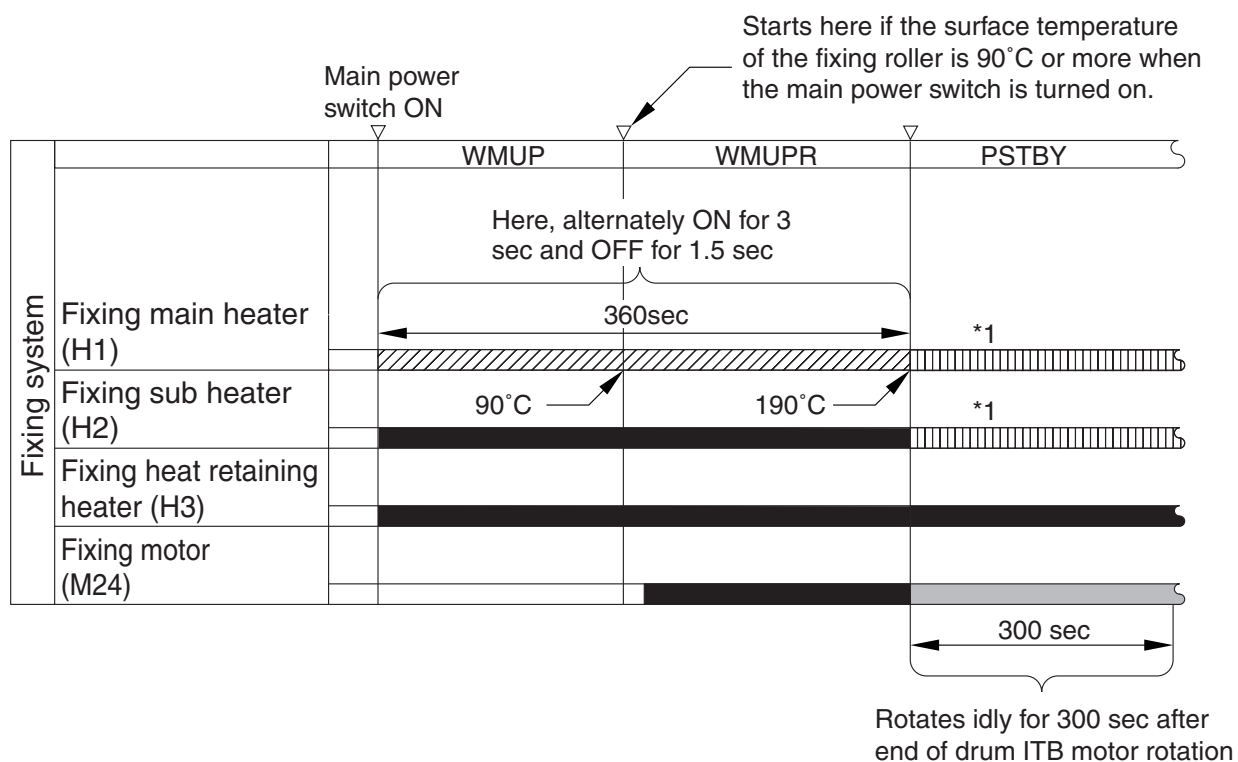

*1: The main heater or the sub heater performs temperature control (to 190°C) according to the reading of the main thermistor (TH1) or the sub thermistor (TH2).

F06-104-01

1.4.2 Sequence of Operations (printing; plain paper, for less than 180 sec)

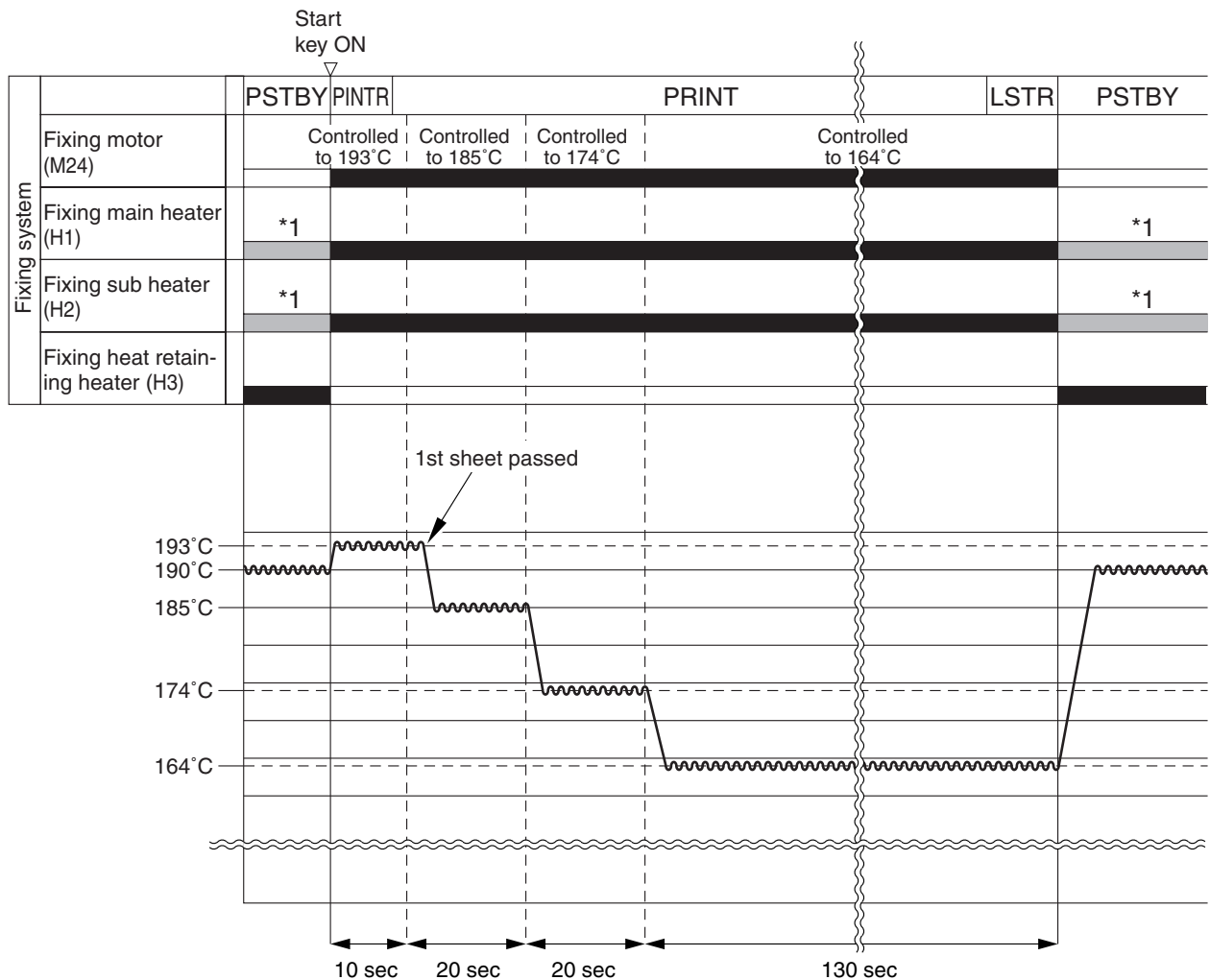

*1: The main heater or the sub heater performs temperature control (to 190°C) according to the reading of the main thermistor (TH1) or the sub thermistor (TH2).

F06-104-02

1.4.3 Basic Sequence of Operations (during printing; plain paper, for 180 sec or more)

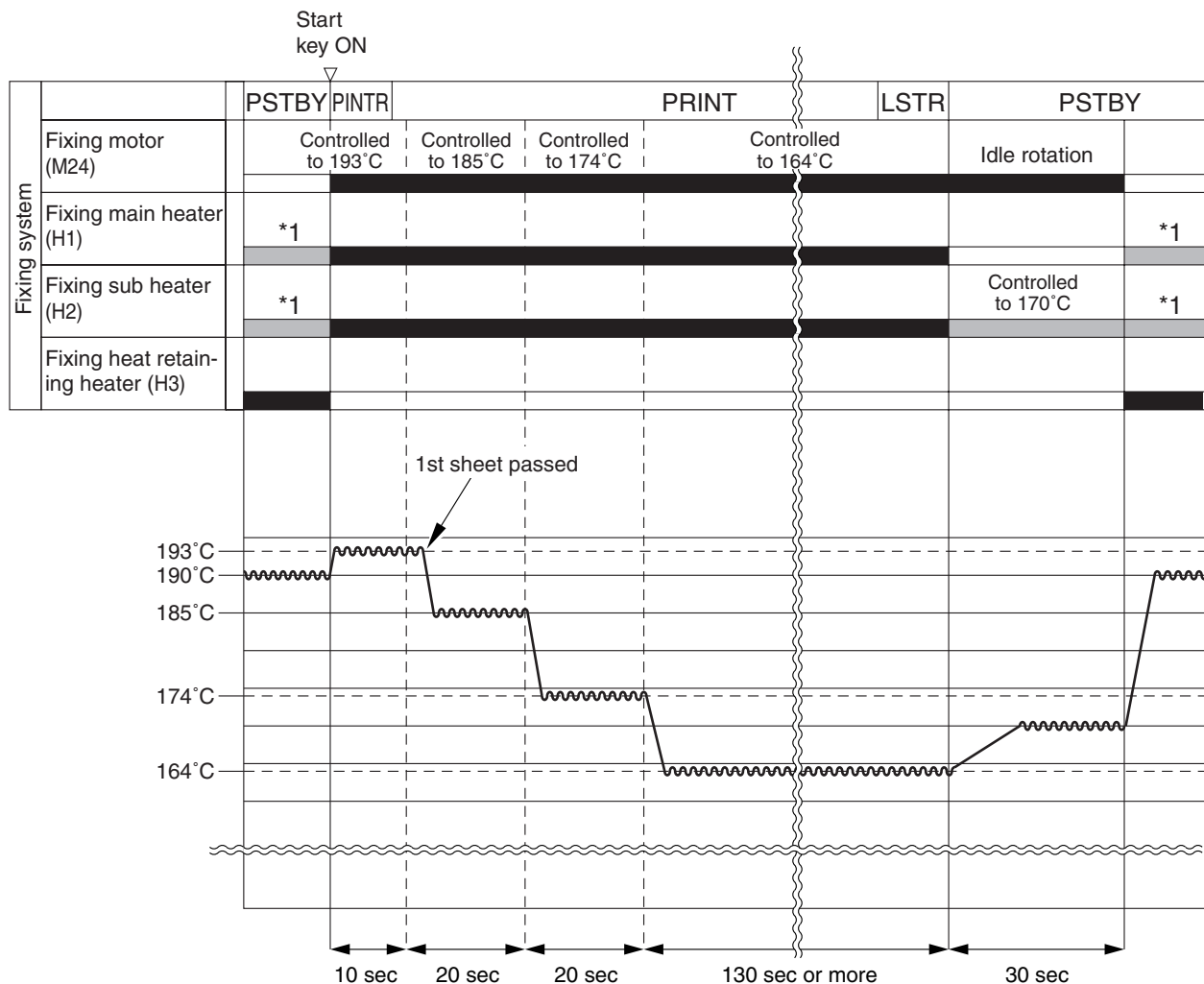

*1: The main heater or the sub heater performs temperature control (to 190°C) according to the reading of the main thermistor (TH1) or the sub thermistor (TH2).

F06-104-03

2 Various Control

2.1 Fixing Drive System

2.1.1 Outline

The fixing roller is driven by a pulse motor used exclusively for it; the roller is controlled for the following:

1. speed to suit the type of medium used
2. speed to suit the (large) quantity of printing work
3. configuration to prevent partial deformation otherwise caused by a long period of no use

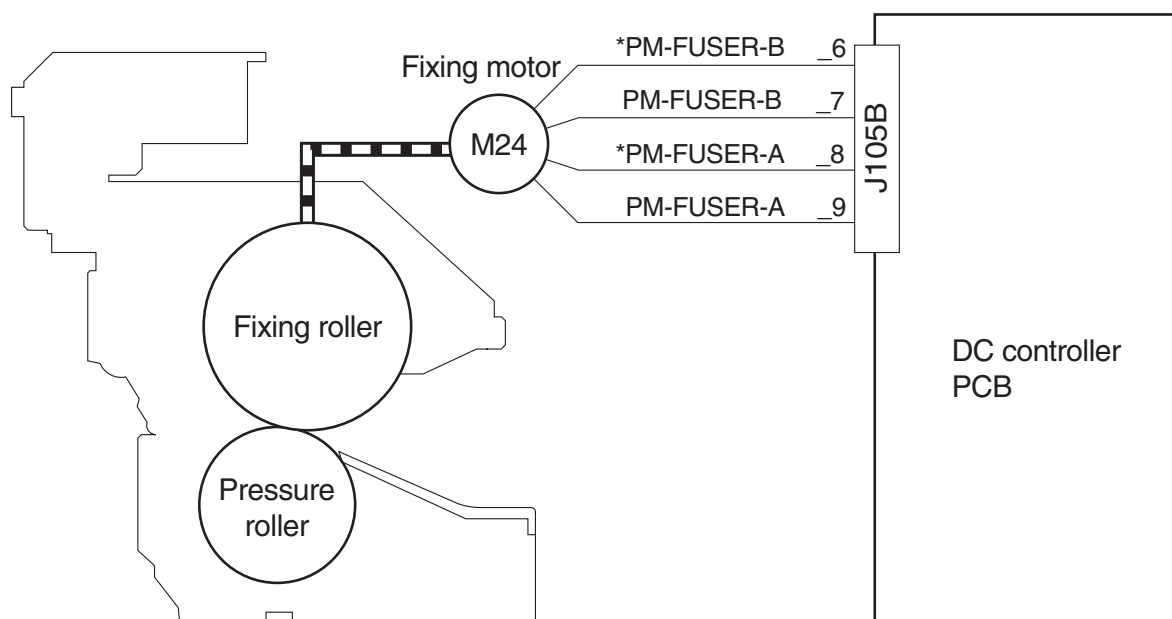

F06-201-01

2.1.2 Controlling the Speed of the Fixing Roller

a. Controlling the Speed According to the Type of Paper

The machine controls the fixing roller to the following 2 speeds to suit the type of medium used:

Medium	Fixing speed
Plain paper	129.1 mm/sec
Thick paper	64.55 mm/sec
Monochrome transparency	129.1 mm/sec
Color transparency	64.55 mm/sec

Note: The speed of the fixing roller is reduced (to half) to ensure good fixing on thick paper (thick paper speed) or on a full-color transparency (full-color transparency mode).

b. Controlling the Speed According to the Quantity of Printing

If left unattended, the heat of the pressure roller would be absorbed by paper when a large quantity of printing is under way, causing the paper to curl appreciably upon delivery and, thus, making proper stacking difficult.

To prevent excess curling, the speed of the roller is reduced to half (as set in service mode) when as many as 100 large-size sheets or as many as 200 small-size sheets have been handled.



Service Mode (level 2)

COPIER>OPTION>BODY>DWNSQ-SW

c. Preventing Partial Deformation of the Roller

To prevent deformation otherwise caused by the nip pressure of the fixing roller as occurring when the machine is left unattended for a long period of time, the fixing roller is rotated for 0.5 sec at half speed (64.55 mm/sec) every 30 min after it has stopped (i.e., during standby/low power mode).

2.2 Controlling the Fixing Roller Temperature

2.2.1 Outline

The following figure shows the components associated with the temperature control mechanisms of the fixing roller; for detailed descriptions of these mechanisms, see the pages that follow:

1. at power-on
2. during standby
3. during printing
4. between long sheet intervals
5. in response to overheating in non-paper contact area
6. during return from low-power mode

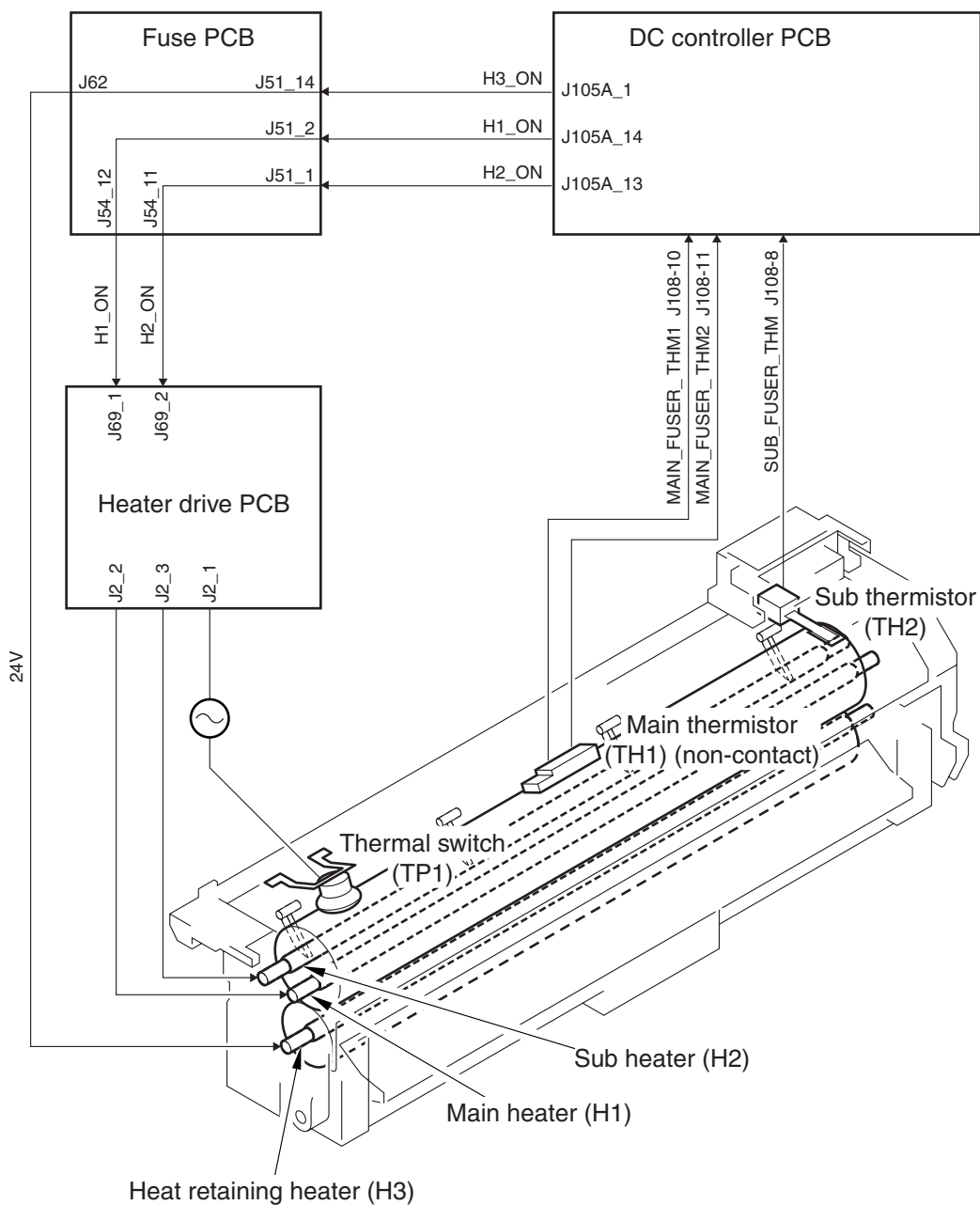

F06-202-01

2.2.2 At Power-On

The fixing roller is heated by 2 fixing heaters (main heater H1, sub heater H2). The main heater repeats remaining ON for 3.5 sec and OFF for 1.5 sec until the fixing temperature reaches 190°C. The sub heater, on the other hand, remains ON throughout.

The pressure roller is kept warm by the heat retaining heater (which remains ON throughout).

The fixing motor starts to rotate when the temperature of the fixing roller reaches 90°C. It keeps rotating for a further 300 sec after the temperature of the fixing roller reaches 190°C (warm-up state; so as to maintain the temperature of the pressure roller; the machine accepts a print job during this period).

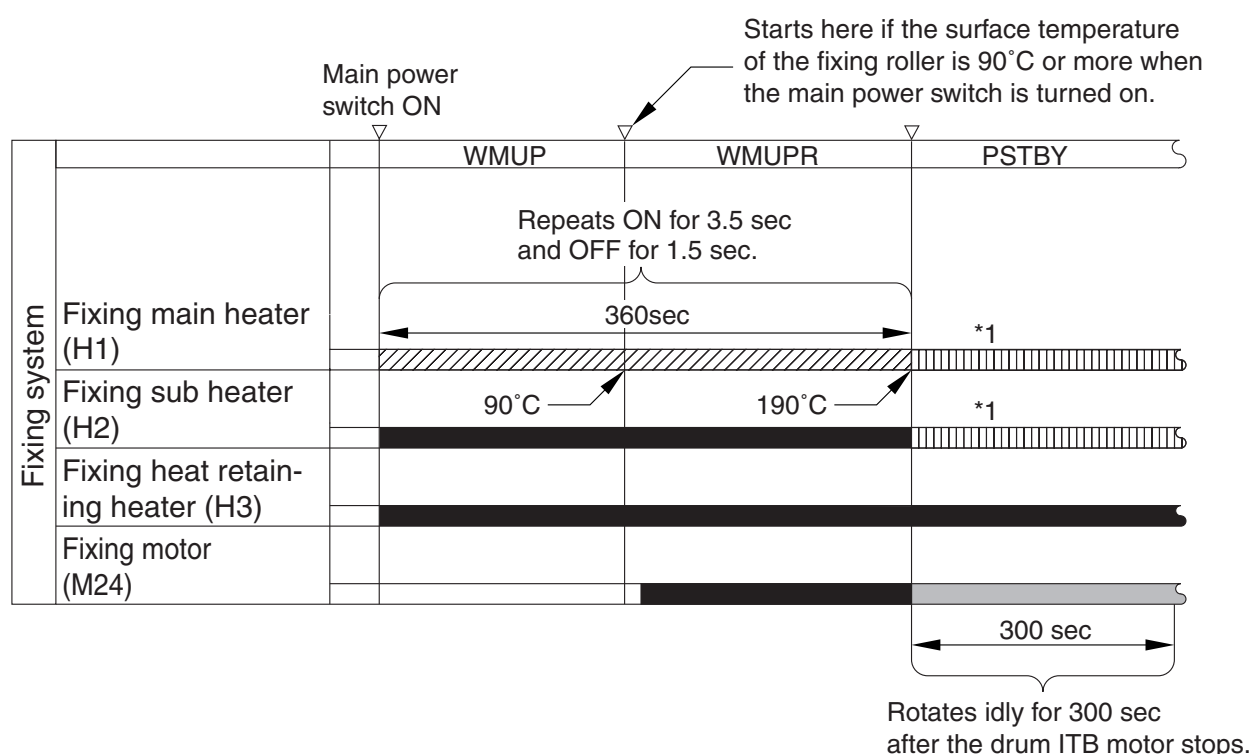

*1: The main thermistor (TH1) or the sub thermistor (TH2) performs temperature control (to 190°C) according to the reading of the main sub heater or the sub heater.

F06-202-02

2.2.3 In Standby

The machine controls the fixing roller (to 190°C) according to the reading of the non-contact thermistor TH1 or sub thermistor TH2. If the reading of the main thermistor is assumed to be Th1 and that of the sub thermistor is assumed to be Th2,

- if $Th1 > Th2$, the temperature control will be by the sub heater.
- if $Th1 \leq Th2$, the temperature control will be by the main heater.

The temperature of the pressure roller is controlled by the heat retaining heater, which repeatedly remains ON for 480 sec and, thereafter, remains ON for 4.2 sec and OFF for 1.6 sec.

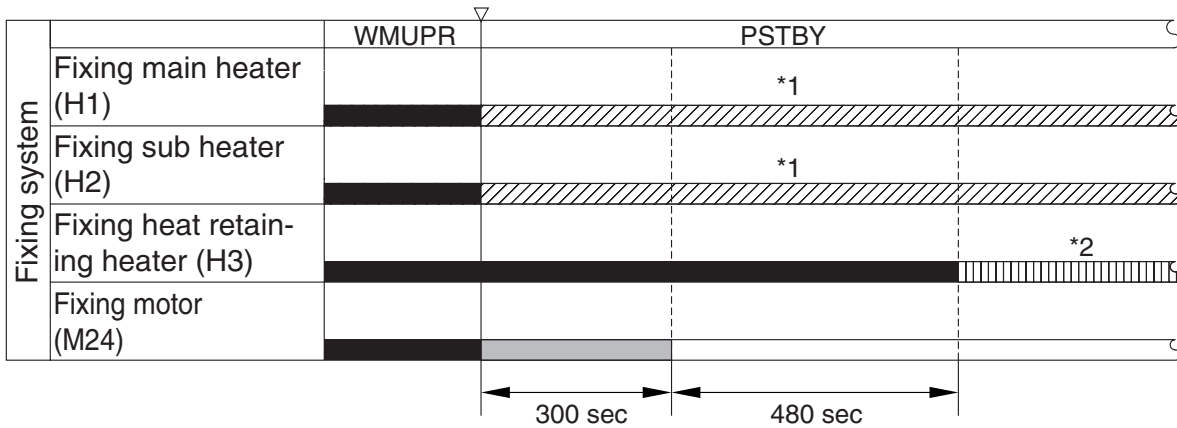

- *1: The main heater or the sub heater performs temperature control (to 190°C) according to the reading of the main thermistor (TH1) or the sub thermistor (TH2).
- *2: The fixing heat retaining heater repeatedly remains ON for 4.2 sec and OFF for 1.6 sec.

F06-202-03

2.2.4 During Printing

The temperature of the fixing roller is controlled by turning on and off the main heater according to the reading taken by the main thermistor. During printing, the control (i.e., timing at which control is initiated) varies according to the type of paper being used.

The following shows the sequence of temperature control when printing on plain paper:

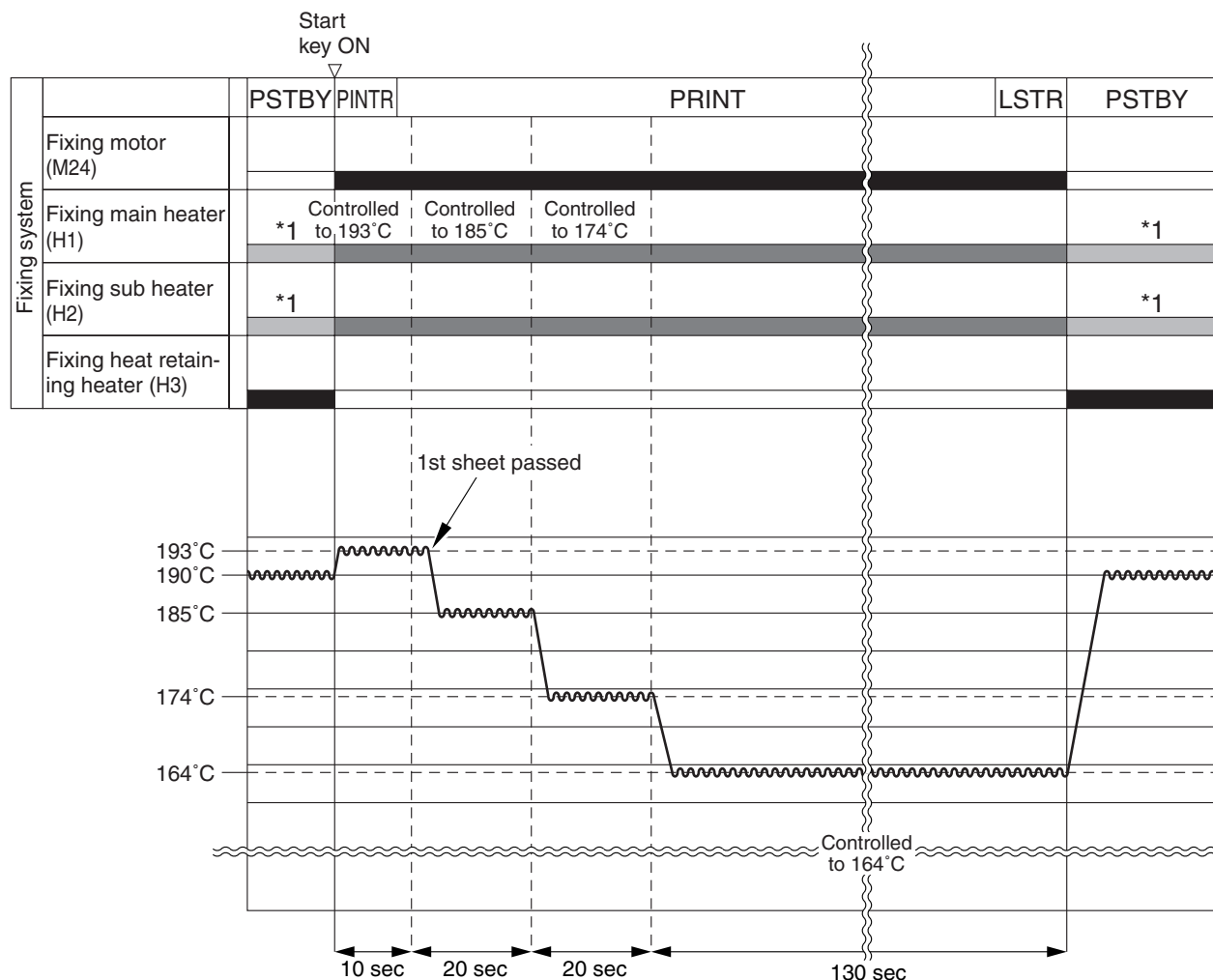

*1: The main heater or the sub heater performs temperature control (to 190°C) according to the reading of the main thermistor (TH1) and the sub thermistor (TH2).

F06-202-04

If a print job exceeds 180 sec, the fixing roller is rotated for 30 sec after the job (so that the heat of the fixing roller is transmitted evenly to the pressure roller).

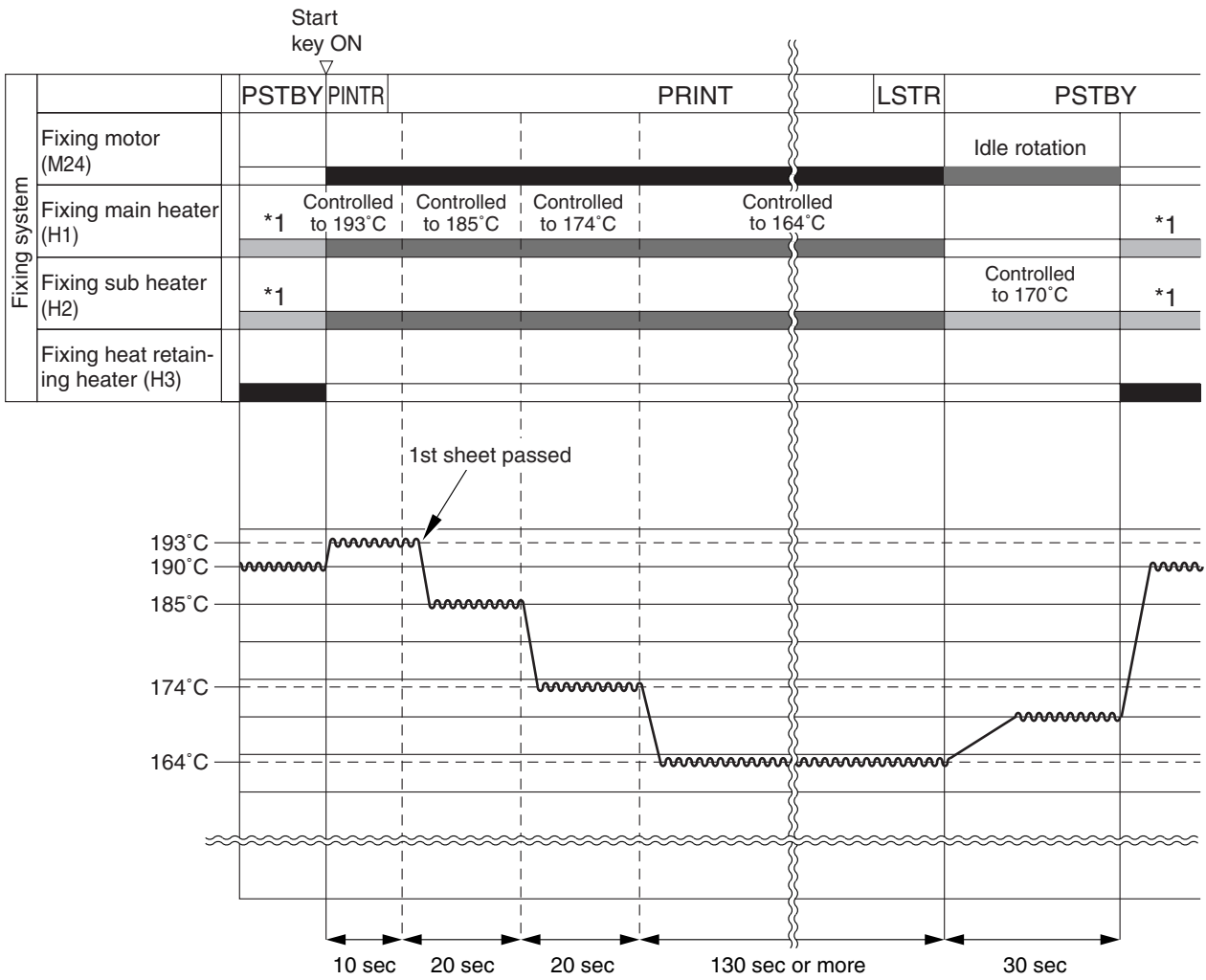

*1: The main heater or the sub heater performs temperature control (to 190°C) according to the reading of the main thermistor (TH1) and the sub thermistor (TH2).

F06-202-05

2.2.5 Between Sheets

The temperature of the fixing roller is controlled over the distance between sheets within a print job:

1. If the distance is 15 sec or more and less than 60 sec,
The fixing temperature sequence and the heater (main/sub) control sequence are continued over the distance.
2. If the distance is 60 sec or more
The fixing temperature control sequence and the heater (main/sub) control sequence are performed over the distance up to 60 sec; thereafter, only the heater sequence control is performed.

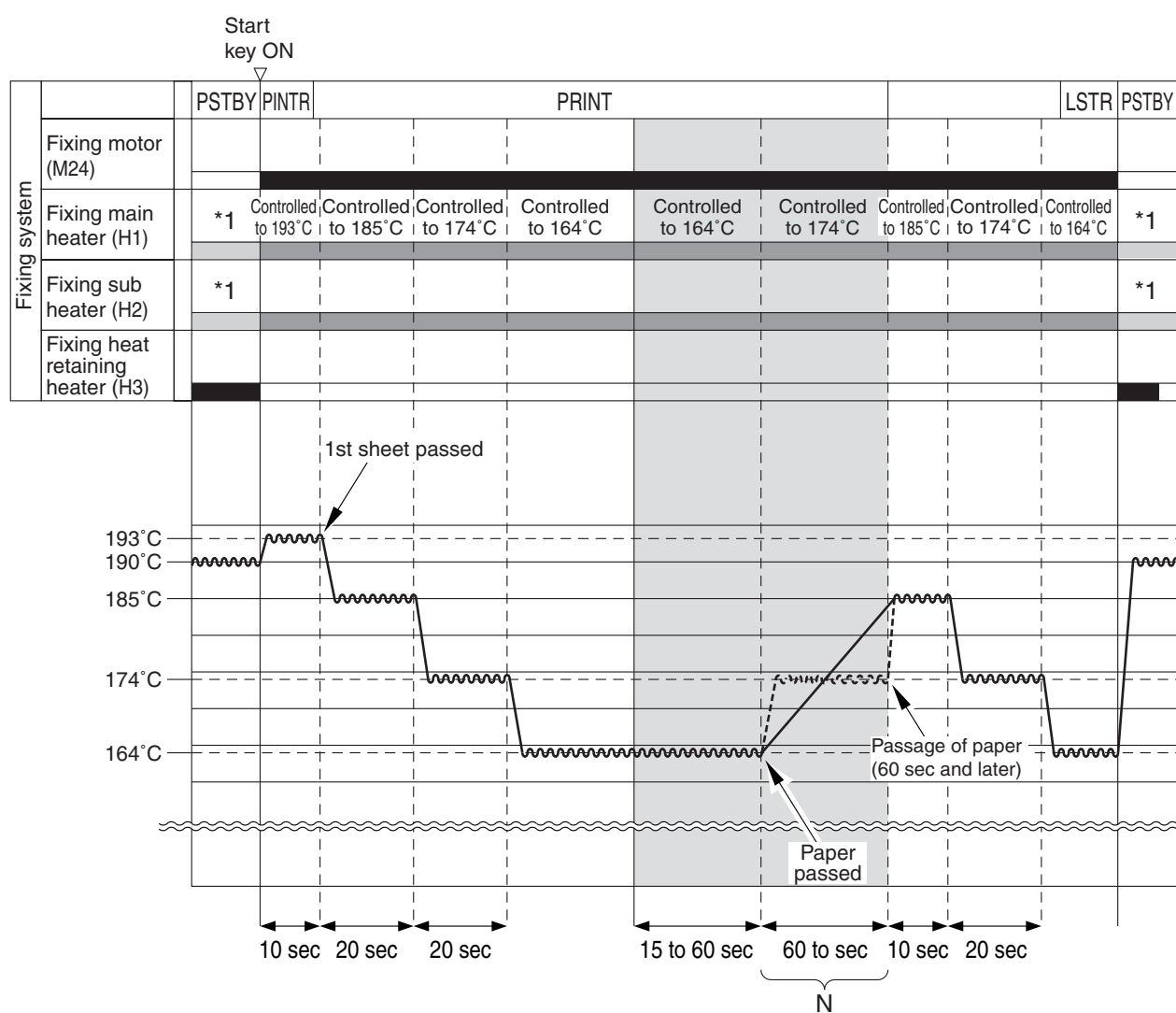

*1: The main heater or the sub heater performs temperature control (to 190°C) according to the reading of the main thermistor (TH1) and the sub thermistor (TH2).

N: sheet-to-sheet distance after 60 sec.

F06-202-06

2.2.6 Overheating in Areas Without Paper

If the sub thermistor (TH2) registers 195°C or more, the machine turns off the sub heater. If it registers 210°C or more, the machine also turns off the main heater.

When the temperature at the ends falls below 210°C, the machine turns on the main heater.

If the temperature at the ends falls below 195°C, the machine also turns on the sub heater.

If the reading of the main thermistor is below the control temperature at this time, the heaters are turned on.

2.2.7 Return for Low-Power Mode

After a lapse of 30 sec, the machine becomes ready to accept a job only in black mono mode. In the case of color mode, the machine will not accept a job until the temperature of the fixing roller reaches 190°C after a lapse of 30 sec.

2.3 Detecting the Passage of Paper

The mechanisms involved in the detection of the passage of paper in the fixing unit are as follows:

1. Fixing Inlet Sensor
Detects passage of paper being moved into the fixing unit.
2. Fixing Delivery Sensor
Detects the passage of paper being moved from the fixing assembly.

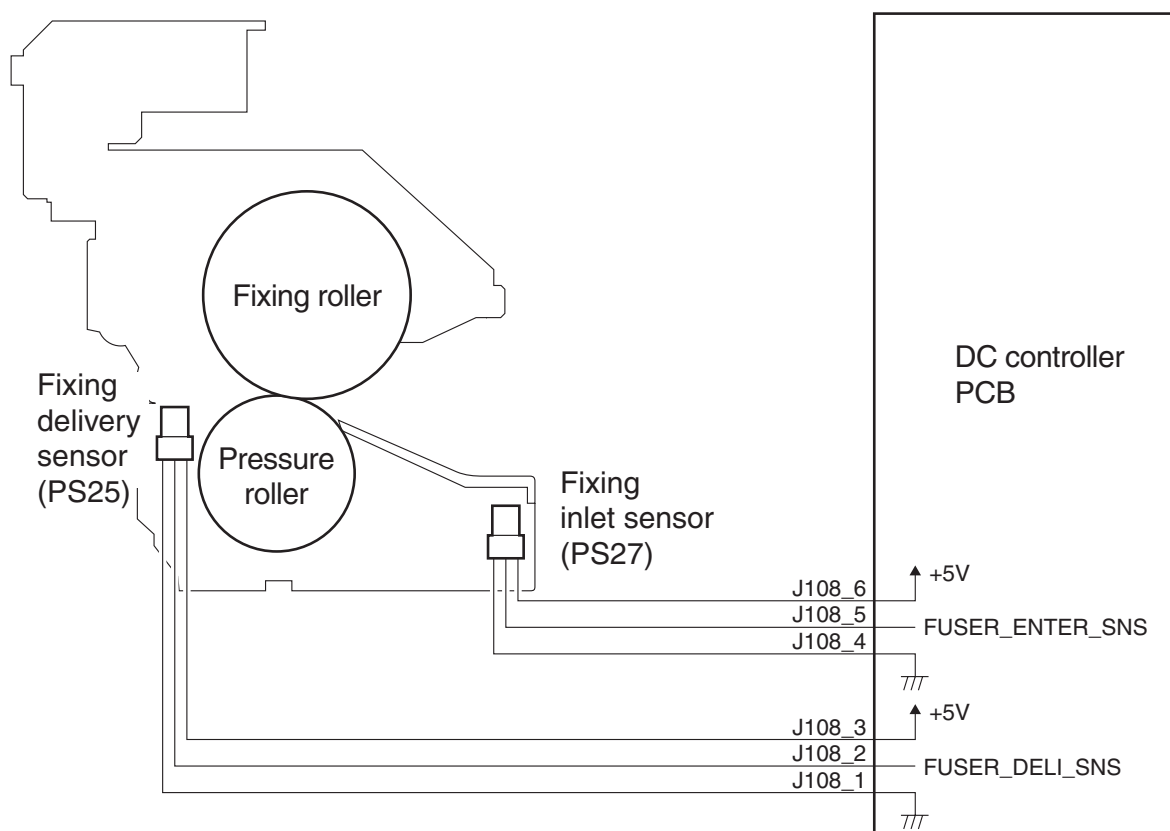

F06-203-01

3 Protective Functions



Once its contact has opened, the thermal switch will not return to its initial state even after the error temperature has been corrected. Be sure to replace it.

3.1 Turning Off the Power Against Overheating (in response to activation of thermal switch)

If the internal temperature of the thermal switch exceeds $222 \pm 8^{\circ}\text{C}$, the thermal switch goes OFF to cut the power to the fixing heater.

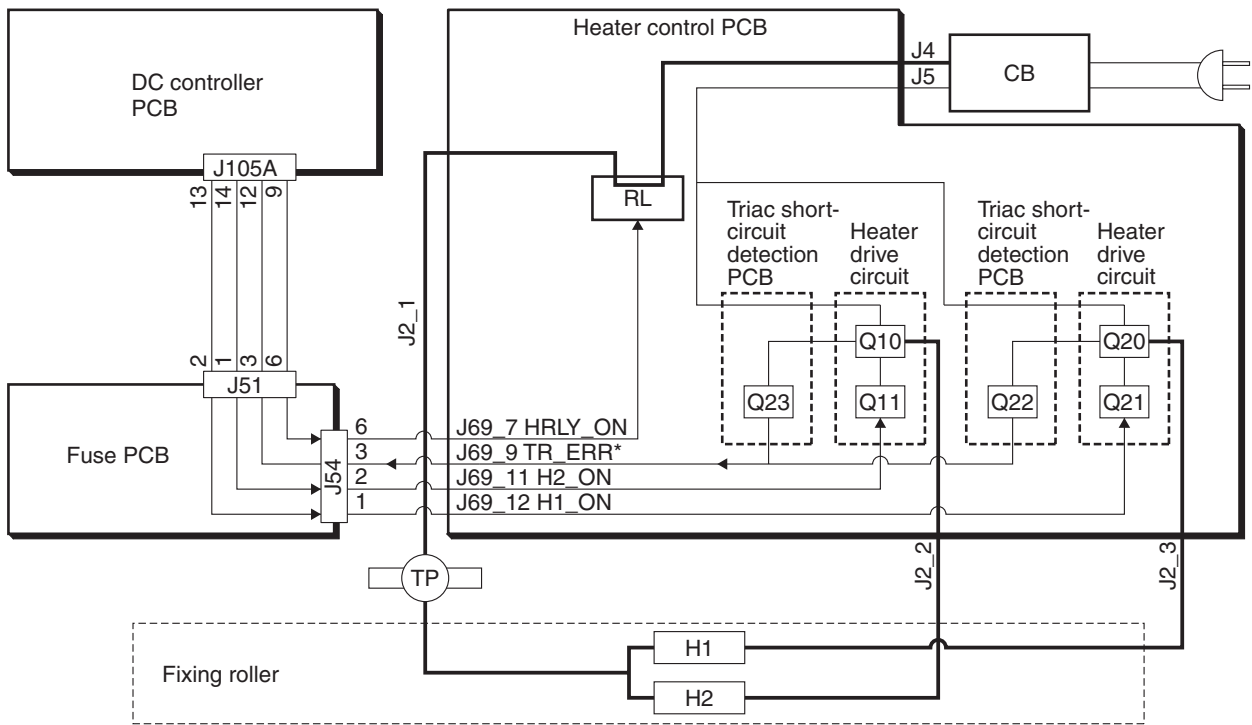

F06-301-01

3.2 Detecting Overheating by the Thermistors

When the sub thermistor mounted at the end of the fixing roller detects 239°C, the signal from the DC controller turns off the heater drive circuit, thus cutting off power to the main heater and the sub heater.

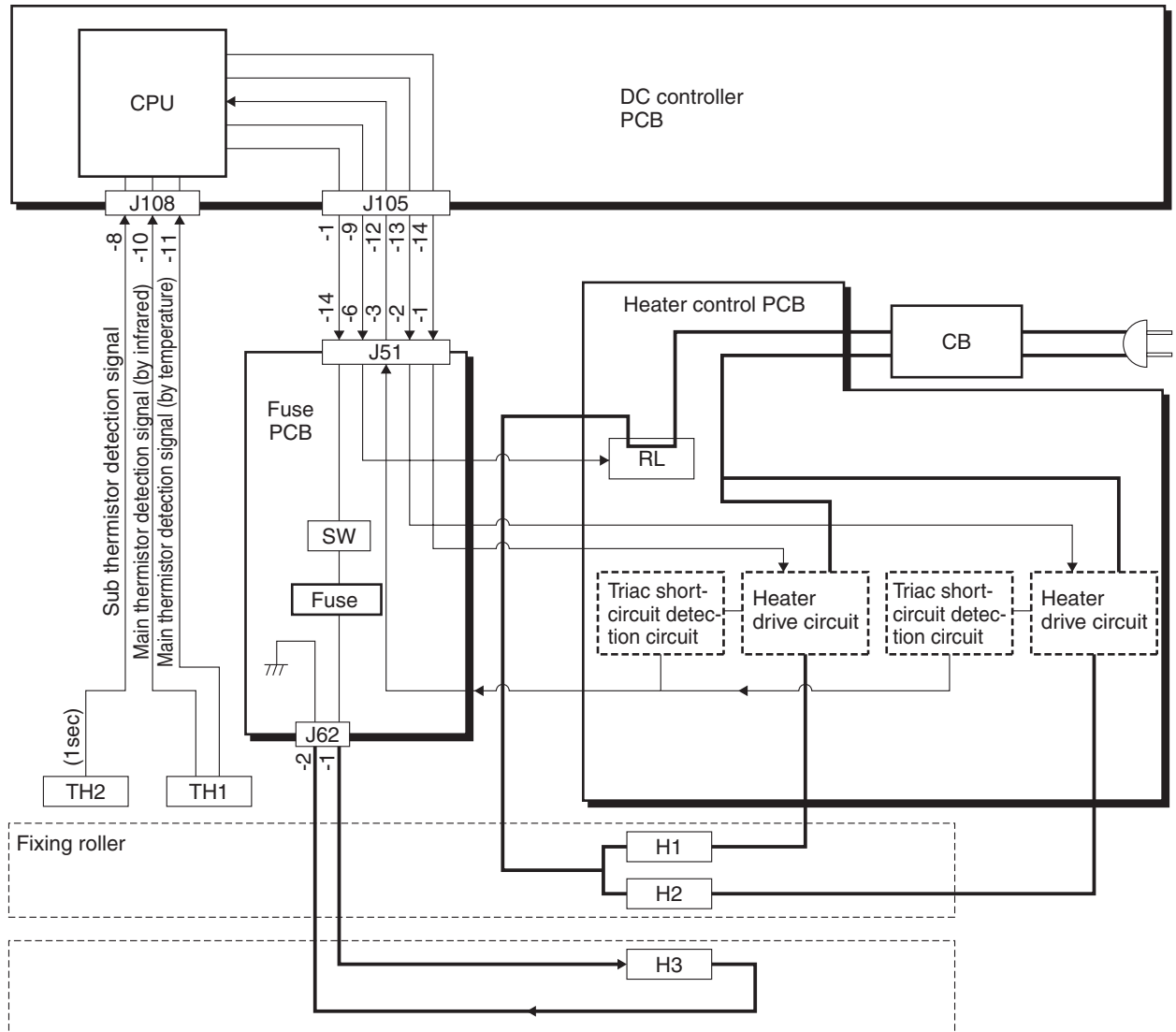

F06-302-01

4 Disassembly and Assembly

4.1 Removing the Fixing Unit

- 1) Withdraw the fixing feeder unit.
- 2) Remove the 2 screws [1], and detach the fixing unit [2].

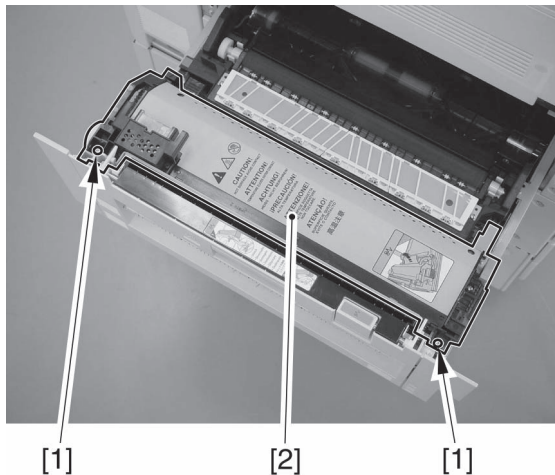

F06-401-01

4.2 After Disassembling the Fixing Unit

If you have loosened the adjusting screw used to secure the upper frame and the lower frame of the fixing unit in place (as when replacing a roller), be sure to adjust the nip of the fixing roller as follows:

- 1) Turn the adjusting screw [1] at the front/rear so that the length of the pressure spring is 31.5 mm.

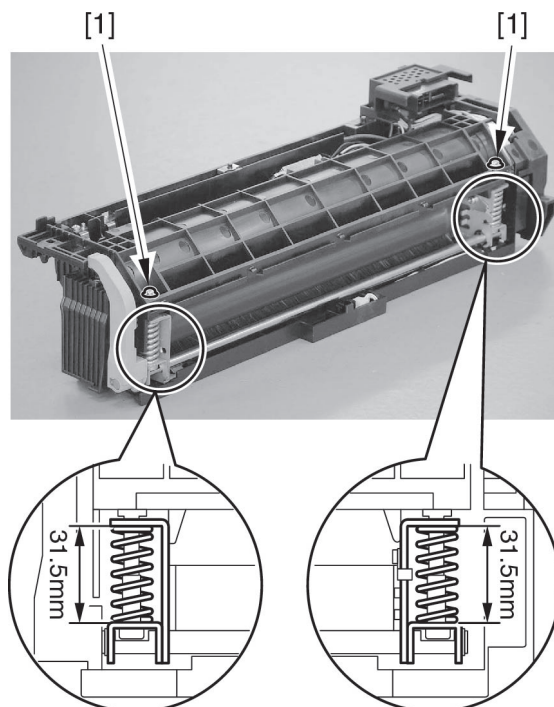

F06-402-01

- 2) Fit the fixing unit in the machine, and execute the following service mode to measure the nip:
COPIER>FUNCTION>FIXING>NIP-CHK.

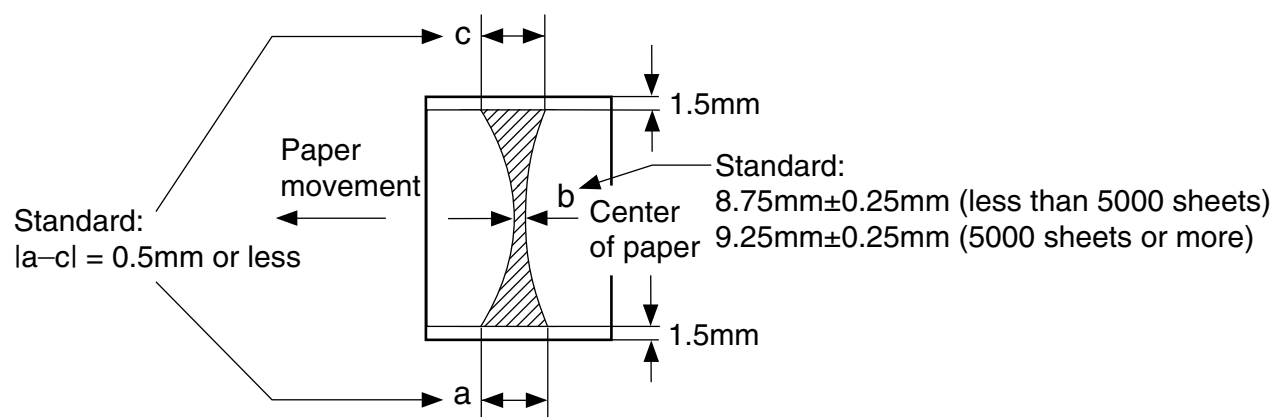

F06-402-02

- 3) Adjust the balance between the front and the rear:
- If the median value of the measured nip is toward the lower limit of the standard, tighten the screw on the side with a lower nip value at the edge.



A 1/2 turn of the screw shifts the nip balance by about 0.4 mm. A 1/2 turn on the screw at the front will increase the nip at the front by 0.3 mm, decreasing the nip at the rear by 0.2 mm.

- If the median value of the measured nip is toward the higher limit of the standard, tighten the screw on the side with a higher nip value at the edge.
- If the nip needs adjustment while the nip balance is correct, the adjusting screws both at the front and rear may be given a 1/2 turn so that the nip may change by about 0.3 mm.

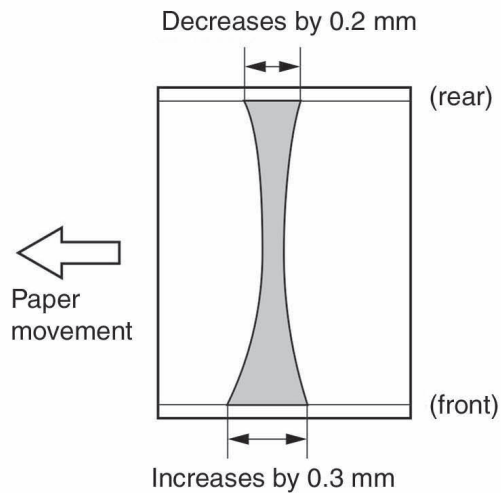
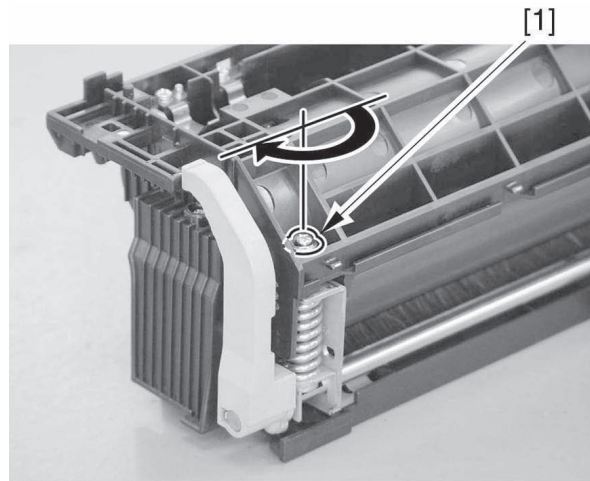

F06-402-03

4.3 Removing the Delivery Upper Guide

- 1) Withdraw the fixing feeder unit.
- 2) Remove the fixing unit.
- 3) Remove the insulating cover fixing plate [1]. (3 snap-on claws)

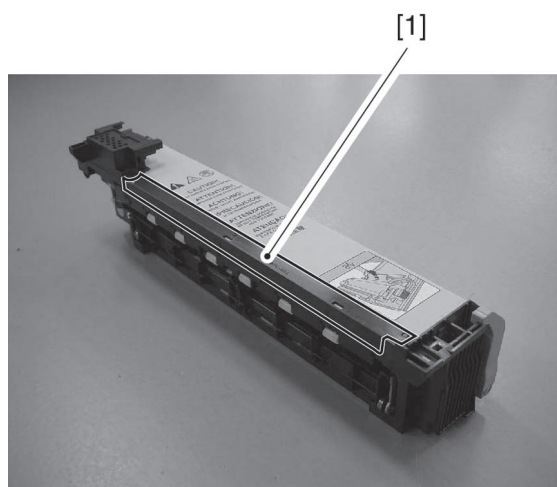

F06-403-01

- 4) Remove the insulating cover [1].

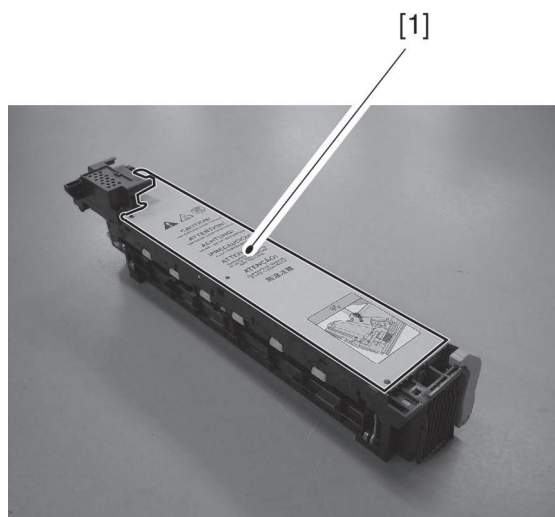

F06-403-02

- 5) Remove the rear cover [1]. (2 snap-on claws)

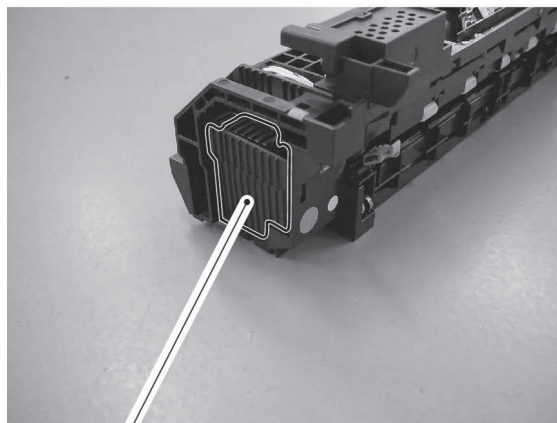

[1]

F06-403-03

- 6) Pick the tab [2] of the lower guide [1], and free the 4 snap-ons to detach the delivery upper guide [3].

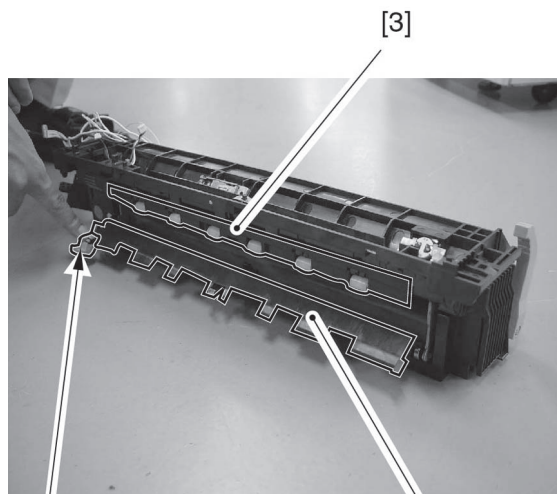

[2]

[1]

F06-403-04

4.4 Removing the Fixing Inlet Guide

- 1) Withdraw the fixing feeder unit.
- 2) Remove the fixing unit.
- 3) While pushing its claw [2] at the front, detach the fixing inlet guide [1] to the front.

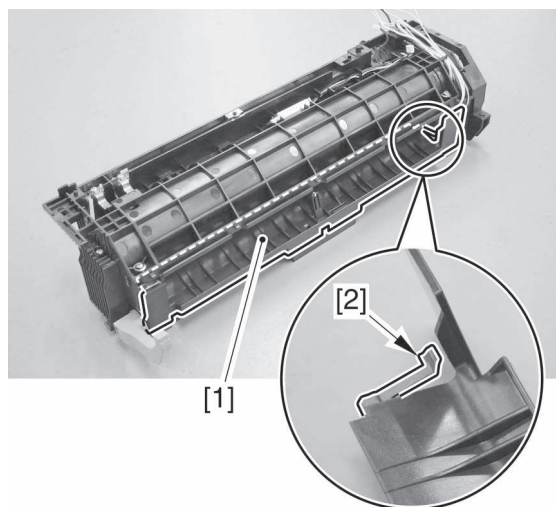

F06-404-01

4.5 Removing the Fixing Upper Frame

- 1) Remove the delivery upper guide. (See 4.3 'Removing the Delivery Upper Guide.')
- 2) Remove the 2 screws [2] of the grounding wire. (AC heater line)

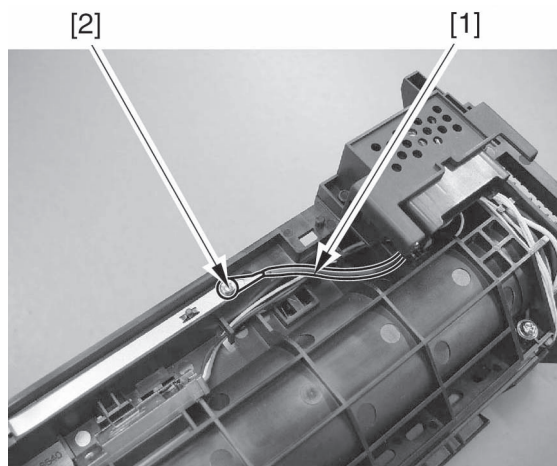

F06-405-01

- 3) Remove the 2 screws [1], and detach the drawer connector [2].

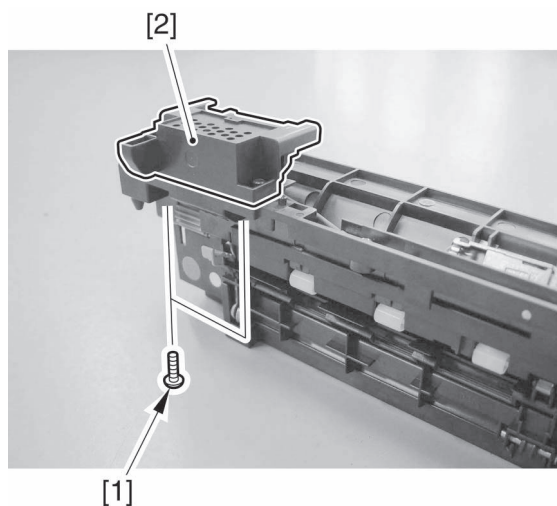

F06-405-02

- 4) Disconnect the 2 connectors [1] (for the thermistor/thermal switch).

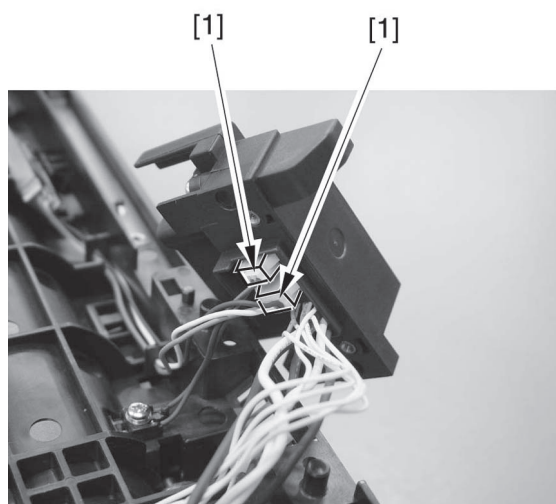

F06-405-03

- 5) Remove the 2 adjusting screws [1].

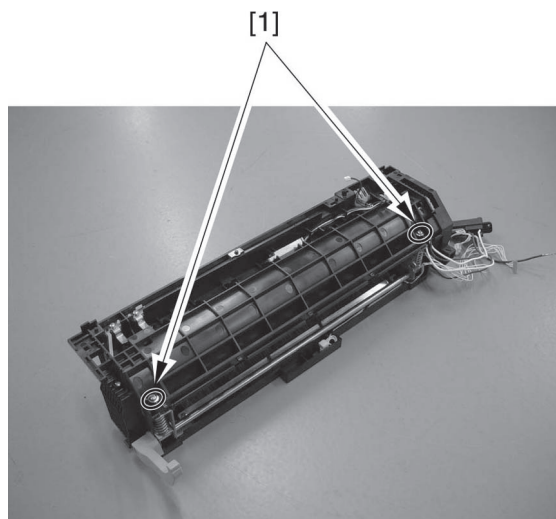

F06-405-04

- 6) Remove the shaft [1] (used to secure the fixing upper frame/lower frame) in place and the gear [2].

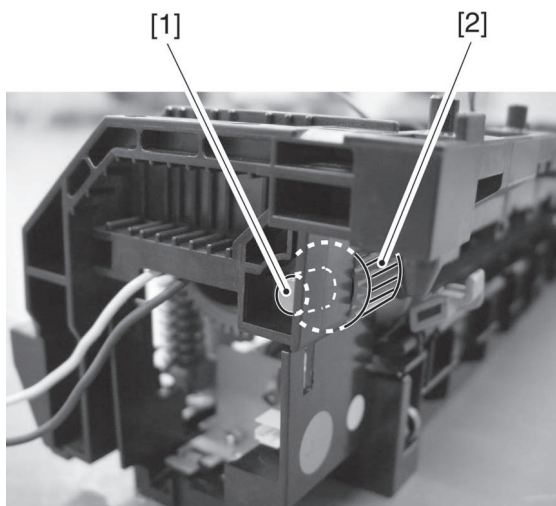

F06-405-05

- 7) Remove the shaft [1] (used to secure the fixing upper frame/lower frame) at the front.

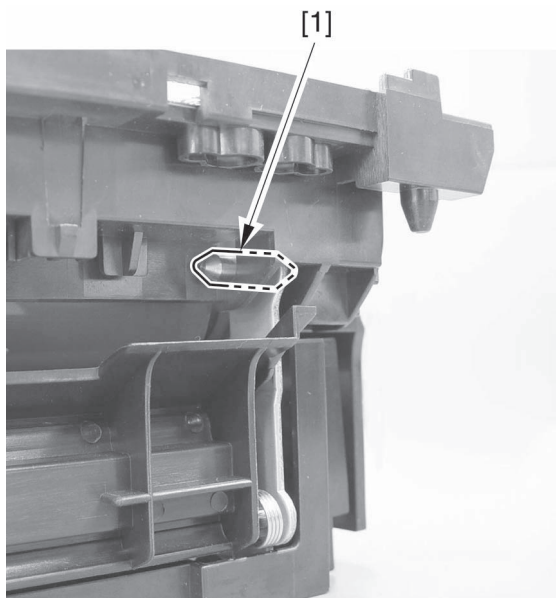

F06-405-06

- 8) Separate the fixing upper frame and the lower frame, and detach the fixing upper frame [1].

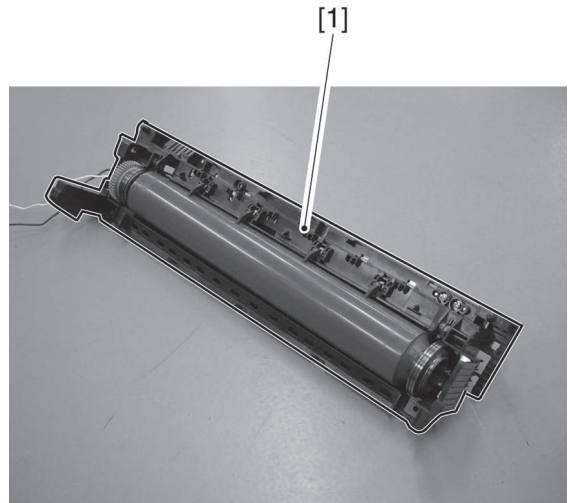

F06-405-07

4.6 Remove the Fixing Main Heater and the Fixing Sub Heater

- 1) Withdraw the fixing feeder unit.
- 2) Remove the fixing unit.
- 3) Remove the fixing upper frame.
- 4) Remove the heater retaining spring (needle-shaped) [1] at the rear.

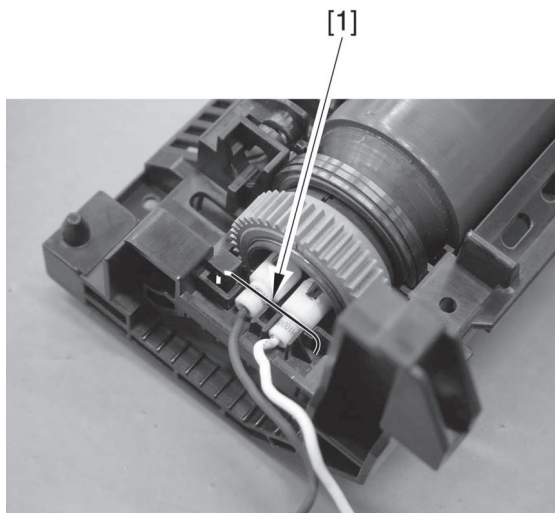

F06-406-01

- 5) Remove the 2 screws [1] from the end of the heater at the front.

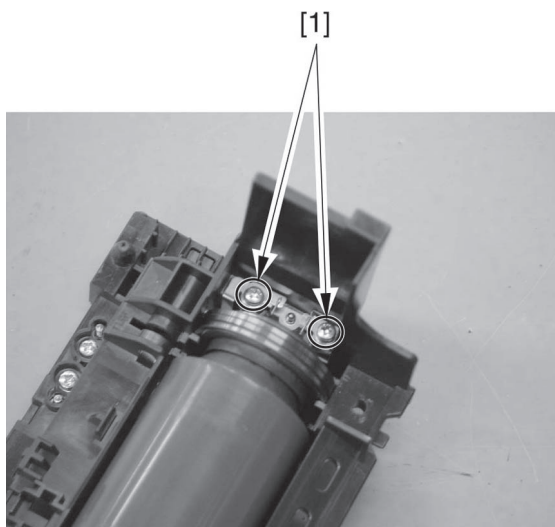

F06-406-02

- 6) Pull out the fixing main heater [1] and the fixing sub heater [2].

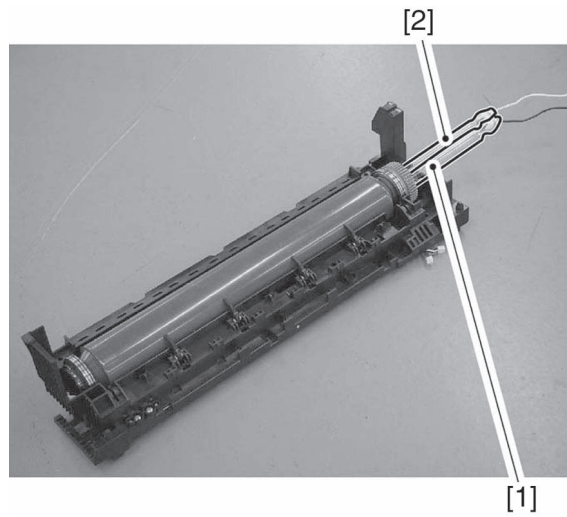

F06-406-03

4.7 Removing the Fixing Roller

- 1) Withdraw the fixing feeder unit.
- 2) Remove the fixing unit.
- 3) Remove the main heater and the sub heater. (See 4.5 'Removing the Main Heater and the Sub Heater.')
- 4) Remove the separation claw [1].

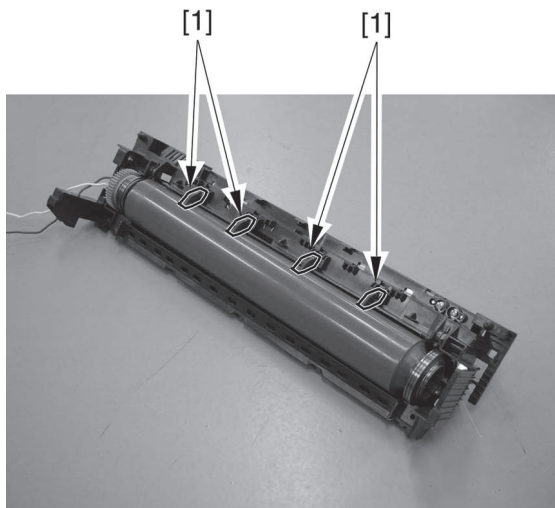

F06-407-01



When attaching the separation claw, be sure that it is mounted as indicated.

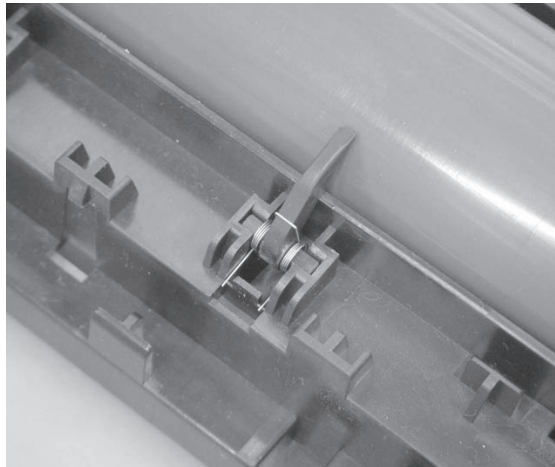

F06-407-02

5) Remove the fixing roller [1].

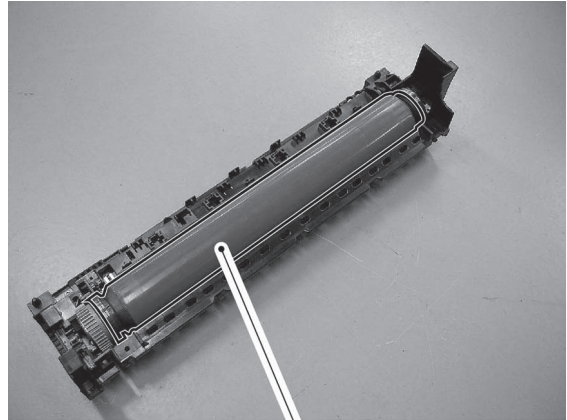

[1]

F06-407-03

4.8 Removing the Fixing Temperature Retainer Heater

- 1) Withdraw the fixing feeder unit.
- 2) Remove the fixing unit.
- 3) Separate the upper frame and the lower frame.
- 4) Disconnect the connector [1], and pull out the 2 fastons [2].

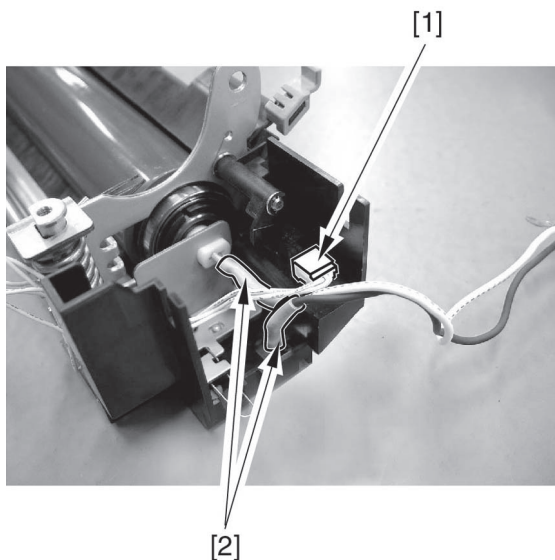

F06-408-01

- 5) Remove the screw [1] from the sub heater contact at the front.

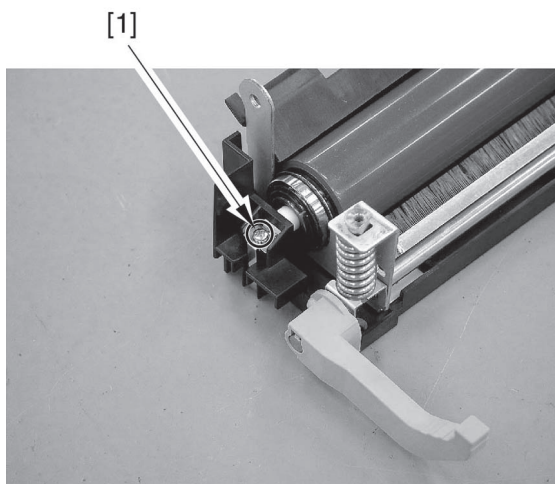

F06-408-02

- 6) Remove the screw [1] at the rear, and detach the heater retaining plate [2].

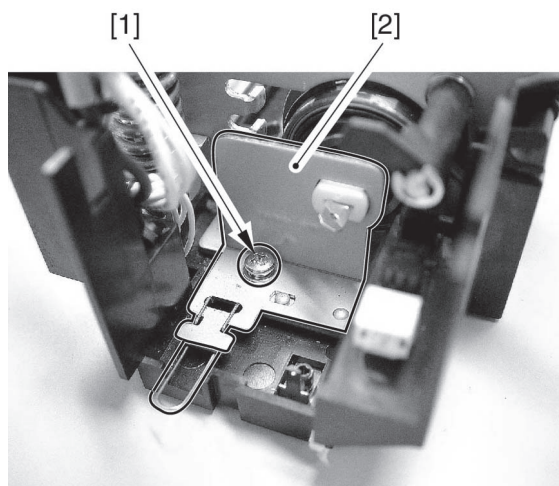

F06-408-03

- 7) Remove the fixing heat retaining heater [1].

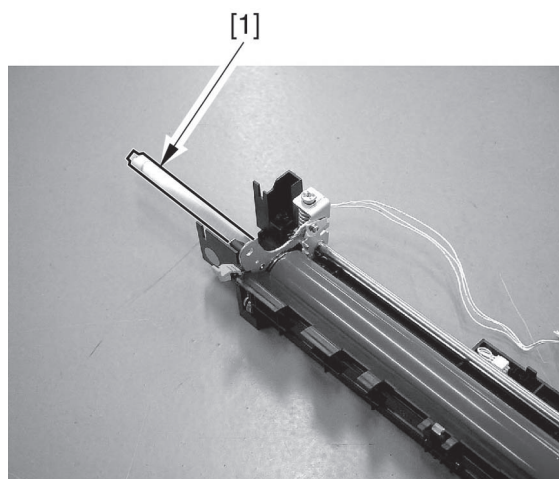

F06-408-04

4.9 Removing the Pressure Roller

- 1) Withdraw the fixing feeder unit.
- 2) Remove the fixing unit.
- 3) Separate the upper frame and the lower frame.
- 4) Remove the fixing heat retaining heater.
(See 4.7 'Removing the Fixing Heat Retaining Heater.')
- 5) While opening the delivery lower guide [1], remove the pressure roller [2].

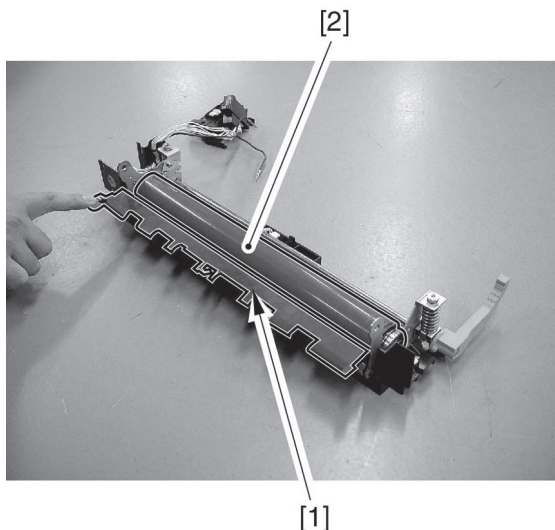

F06-409-01

4.10 Removing the Fixing Main Thermistor

- 1) Withdraw the fixing feeder unit.
- 2) Remove the fixing unit.
- 3) Separate the upper frame and the lower frame.
- 4) While freeing the retaining screw [1] of the upper frame, detach the fixing main thermistor [2].

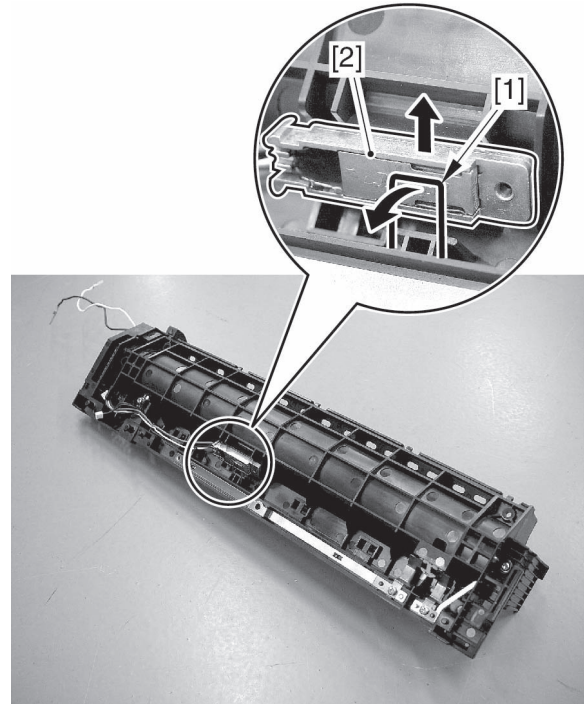

F06-410-01



When attaching, be sure so that the retaining spring forces the fixing thermistor in place.

4.11 Removing the Fixing Sub Thermistor

- 1) Withdraw the fixing feeder unit.
- 2) Remove the fixing unit.
- 3) Separate the upper from and the lower frame.
- 4) Remove the screw [1], and detach the fixing sub thermistor [2].

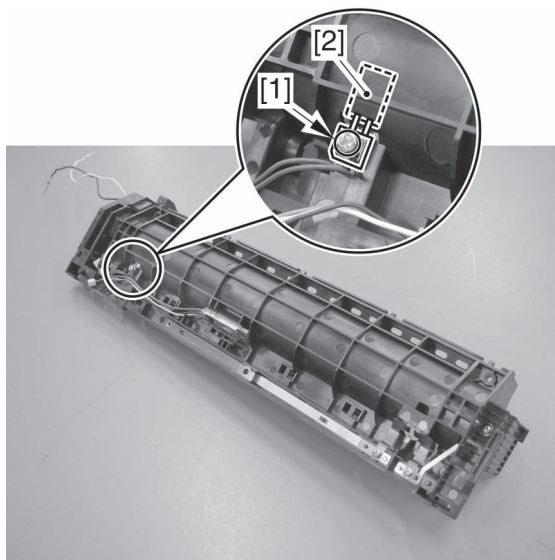

F06-411-01

4.12 Removing the Fixing Thermal Switch

- 1) Withdraw the fixing feeder unit.
- 2) Remove the fixing unit.
- 3) Separate the upper frame and the lower frame.
- 4) Remove the 2 screws [1] of the upper frame, and detach the fixing thermal switch [2].

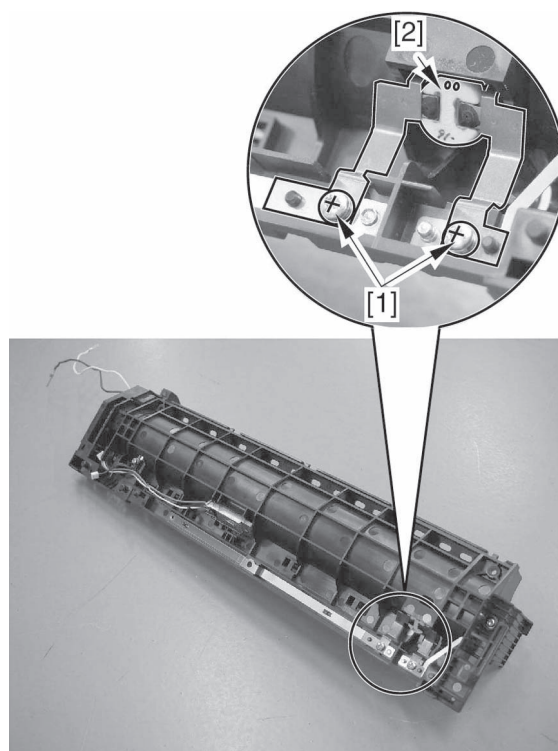

F06-412-01



When mounting, be sure so that the leaf spring of the fixing thermal switch is in contact with the rib of the upper frame.

4.13 Removing the Fixing Inlet Sensor

- 1) Withdraw the fixing feeder unit.
- 2) Remove the fixing unit.
- 3) Separate the upper frame and the lower frame.
- 4) Disconnect the connector [1] from the lower frame side, and detach the fixing inlet sensor [2].

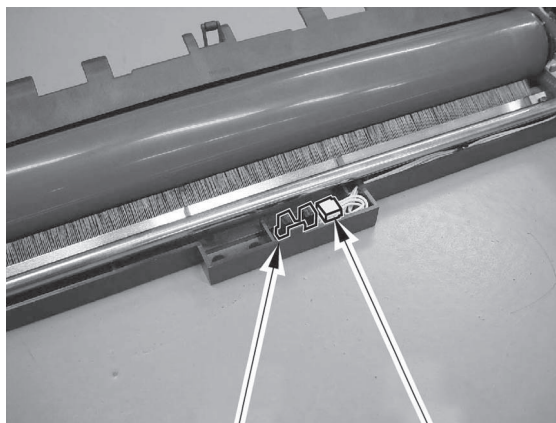

[2]

[1]

F06-413-01

4.14 Removing the Fixing Delivery Sensor

- 1) Withdraw the fixing feeder unit.
- 2) Remove the fixing unit.
- 3) Separate the upper frame and the lower frame.
- 4) Detach the fixing delivery sensor [1] from the lower frame side.

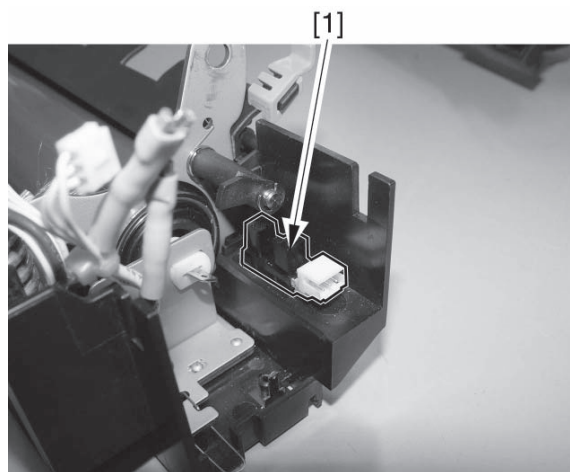

F06-414-01

4.15 Remove the Delivery Lower Guide

- 1) Withdraw the fixing feeder unit.
- 2) Remove the fixing unit.
- 3) Remove the pressure roller.
- 4) Remove the mounting screw [1] of the static eliminator.

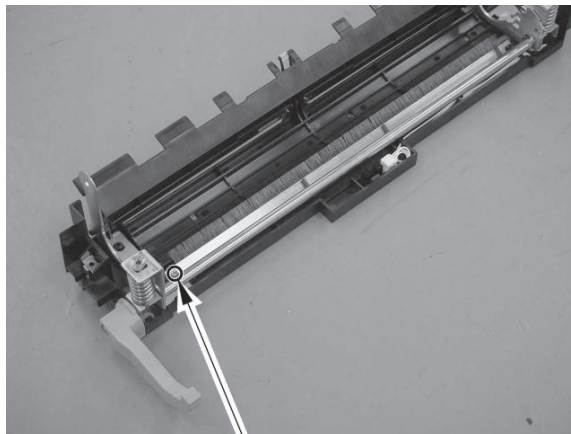

[1]

F06-415-01

- 5) Remove the fixing pin [1] of the delivery lower guide.

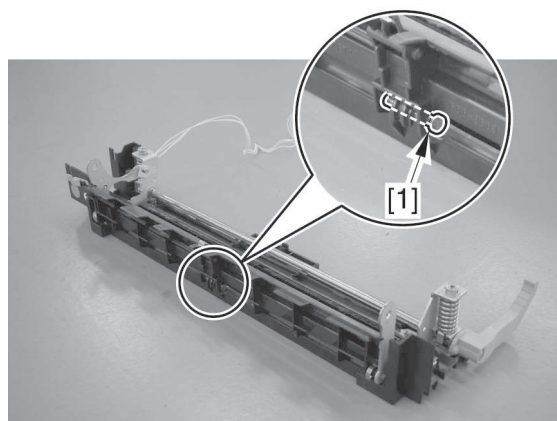

F06-415-02

6)



When removing the side plate at the front/rear, be sure to start at the rear. Otherwise, the side plate at the rear can break the boss on the lower frame.

Remove the 2 screws [1] from the bottom face of the lower frame, and detach the side plate [2] at the front and the side plate [3] at the rear (the releasing shaft [4] and the delivery lower guide [5] are kept attached).

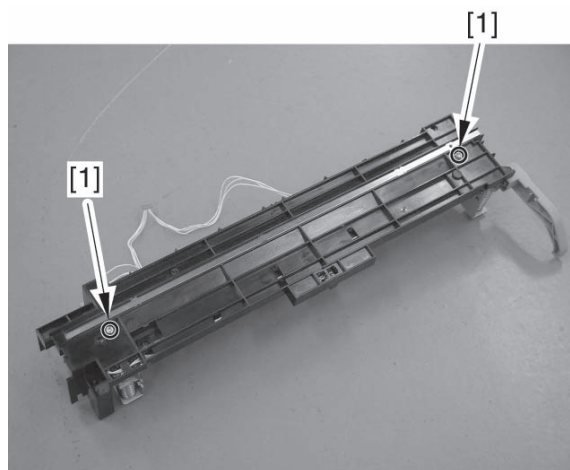

F06-415-03

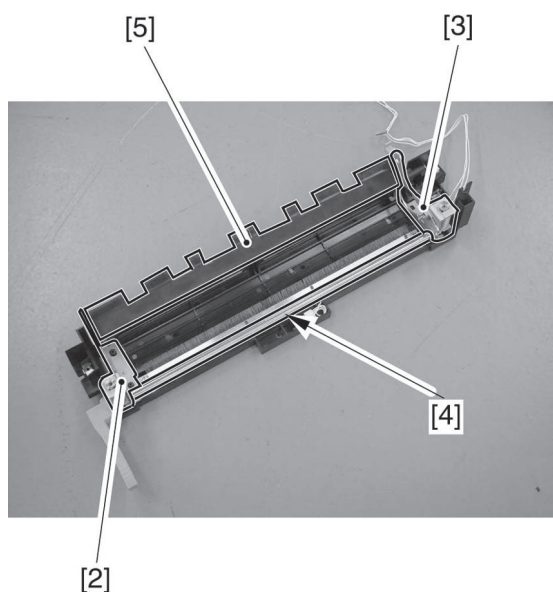

F06-415-04

- 7) Remove the delivery lower guide [1] from the front/rear side plate.

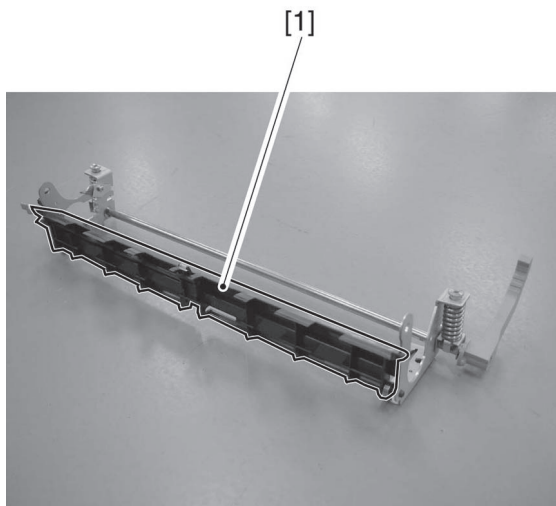

F06-415-05



When mounting, be sure to set the spring [1] on either end of the delivery lower guide as indicated.

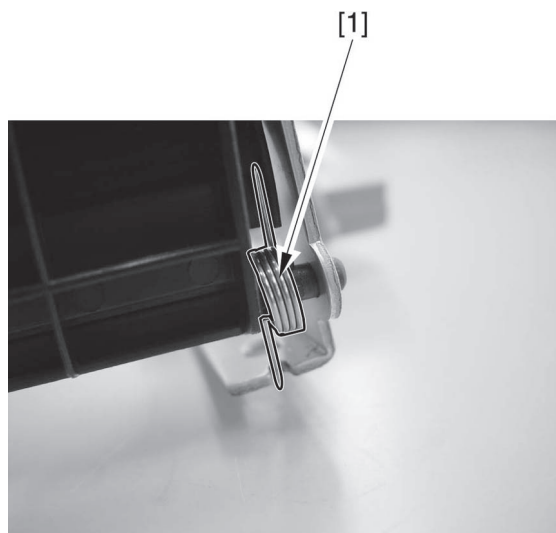

F06-415-06

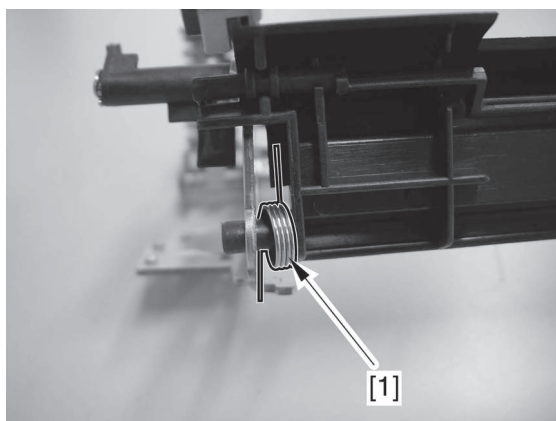

F06-415-07

CHAPTER 7

EXTERNALS AND CONTROLS

1 Control Panel

1.1 Outline

The machine's control panel consists of PCBs, LCD, and touch panel as shown below; the control panel is associated with the following functions:

- LCD indication
- contrast adjustment
- touch switch input
- hard key input

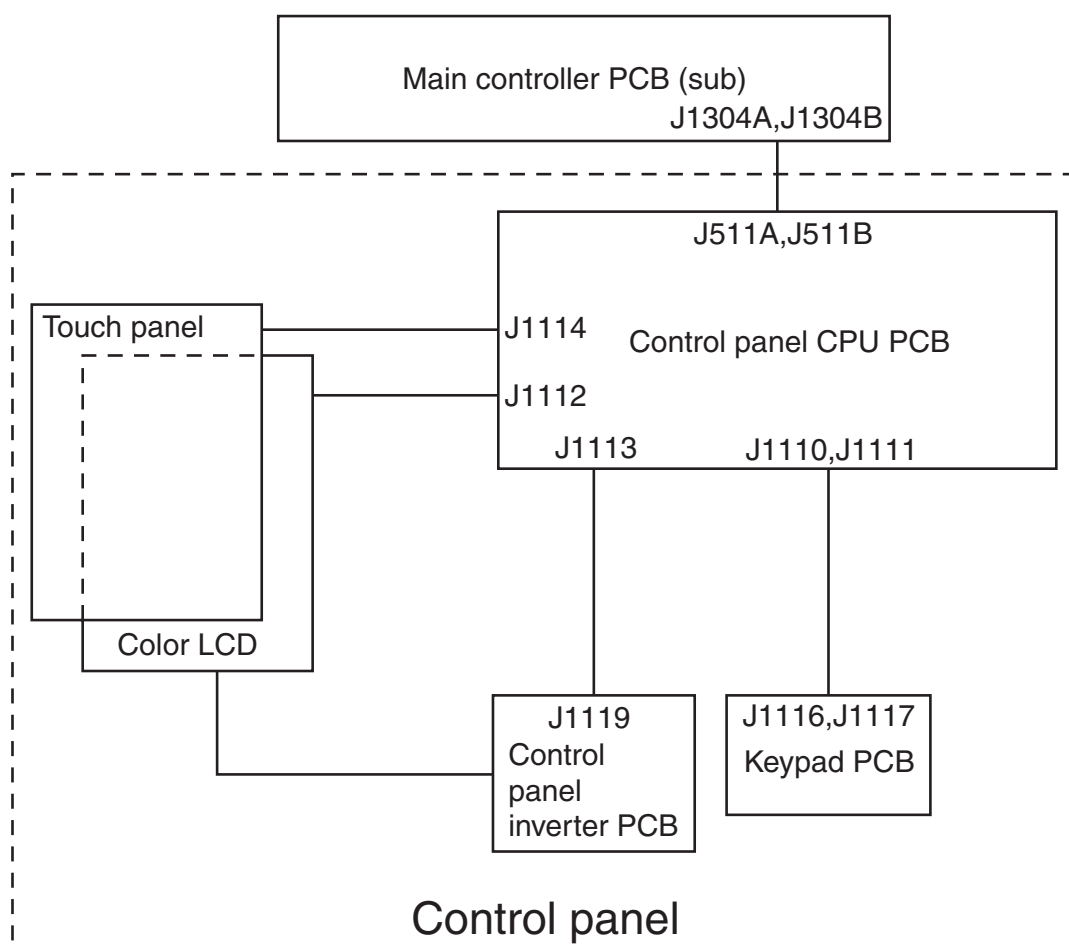

F07-101-01

1.2 Operations

1.2.1 LCD Processing

The CPU on the main controller PCB sends data (display information) to the control panel CPU PCB as instructed by various programs.

The data is moved through the control panel CPU PCB to reach the color LCD.

1.2.2 LCD Contrast Adjustment

The machine is equipped with a dial on its control panel designed for use by the user for adjustment of the LCD contrast.

1.2.3 Functions of the Control Panel CPU

- Monitoring key inputs (relays the inputs made by keypad keys and function keys to the CPU on the main controller PCB)
- Controlling the buzzer sound
- Turning on/off the control panel LEDs

2 Counters

2.1 Outline

The machine is equipped with counters that keep track of the number of prints made according to the type of print; a specific counter reading is shown in response to a press on the Check key on the control panel.

The particulars of the counter settings made at time of shipment from factory and grouped by model are as follows:

Model	Counter 1	Counter 2	Counter 3	Counter 4	Counter 5	Counter 6
100V (*1)	Total 1 101	Total (B&W 1) 108	Copy (full color + mono color/1) 232	Print (full color + mono color/1) 324	(disabled at default) May be changed in service mode 000	(disabled at default) May be changed in service mode 000
120V (*2)	Total 1 101	Total (B&W 1) 108	Copy + print (full color/large) 401	Copy + print (full color/small) 402	Total (mono color/1) 118	(disabled at default) in service mode 000
120V (*3)	Total 1 101	Total (B&W 1) 108	Copy (full color + mono color/large) 229	Print (full color + mono color/small) 230	Print (full color + mono color/large) 321	Print (full color + mono color/small) 322
230V (*4)	Total 1 101	Total (B&W 1) 108	Copy + print (full color/large) 401	Copy + print (full color/small) 402	Total (mono color/1) 118	Total (duplex) 114
240V (*5)	Total 1 101	Copy + print (full color + mono color/large) 407	Copy + print (full color + mono color/small) 408	Total (small) 104	Copy + print (B&W/large) 403	Copy + print (B&W/small) 404
240V (*6)	Total 1 101	Total (B&W 1) 108	Copy (full color + mono color/large) 229	Print (full color + mono color/small) 230	Print (full color + mono color/large) 321	Print (full color + mono color/small) 322
230V (*7)	Total 1 101	Copy + print (full color + mono color/large) 407	Copy + print (full color + mono color/small) 408	Total (small) 104	Copy + print (B&W/large) 403	Copy + print (B&W/small) 404
230V (*8)	Total 1 101	Copy + print (full color + mono color/large) 407	Copy + print (full color + mono color/small) 408	Copy + print (B&W/large) 403	Copy + print (B&W/small) 404	Scan (total 1) 501
230V (*9)	Total 1 101	Total (B&W 1) 108	Copy (full color + mono color/large) 229	Print (full color + mono color/small) 230	Print (full color + mono color/large) 321	Print (full color + mono color/small) 322
230V (*10)	Total 1 101	Total (B&W 1) 108	Copy (full color + mono color/large) 229	Print (full color + mono color/small) 230	Print (full color + mono color/large) 321	Print (full color + mono color/small) 322

T07-201-01

Guide to Notations:

large: large-size paper (in excess of 364 mm in feed length; increment by 1)

small: small-size paper (364 mm or less in feed direction)

total: all copies (C + P); increment by 1

duplex: auto duplex copy; increment by 1

3 digits in Counter column: settings in following:

COPIER>OPTION>USER>COUNTER1 through 6

(for details, see description in Service Mode)

- These counters may be set in service mode to serve for different counter readings. (In the case of the 120/230V model, all counters may be assigned different counter readings.)

Medium Order (printer unit)

*1: F14-2412/2413/2416/2417/2512/2514/2516/2518	*2: F14-2501	*3: F14-2531/2532
*4: F14-2541/2560/2570	*5: F14-2551	*6: F14-2561
*7: F14-2571	*8: F14-2581	*9: F14-2591
		*10: F14-2521

T07-201-02

2.2 Incrementing the Counter Reading

The counter reading is incremented differently depending on the selected mode (single-sided or double-sided) and the type of installed accessory:

2.2.1 Signal-Sided Print and 2nd Side of a Double-Sided Print

When making a single-sided print or printing on the 2nd side of a double-sided print, the counter reading is incremented when the trailing edge of paper leaves the machine, as indicated by the output of the following sensor:

Condition	Sensor
Finisher absent	face-down delivery (center tray): center delivery tray full sensor (PS8)
	face-down delivery (copy tray): face-down delivery sensor 2 (PS6)
	face-up delivery (side tray): fixing delivery sensor (PS25)
Finisher present	finisher delivery sensor

T07-202-01

2.2.2 1st Side of a Duplex Print (duplex model only)

The machine identifies the end of printing on the 1st side of a double-sided print and increments the counter reading when the duplex pickup sensor (PS24) goes ON.

3 Fans

3.1 Outline

The names and functions of the fans used inside the machine are as follows:

Notation	Name	Description
FM3	machine cooling fan	cools the drum cartridge and the developing motor
FM2	fixing heat exhaust fan	discharges the heat generated by the fixing assembly to the outside of the machine
FM1	power supply cooling fan	cools the power supply
FM4	cleaner cooling fan	cools the cleaner
FM5	delivery cooling fan	cools the delivery assembly
FM6	manual feed cooling fan	cools the pre-registration motor (duplex model only)
FM7	controller fan	cools the controller
FM8	delivery vertical path fan	cools the paper

T07-301-01

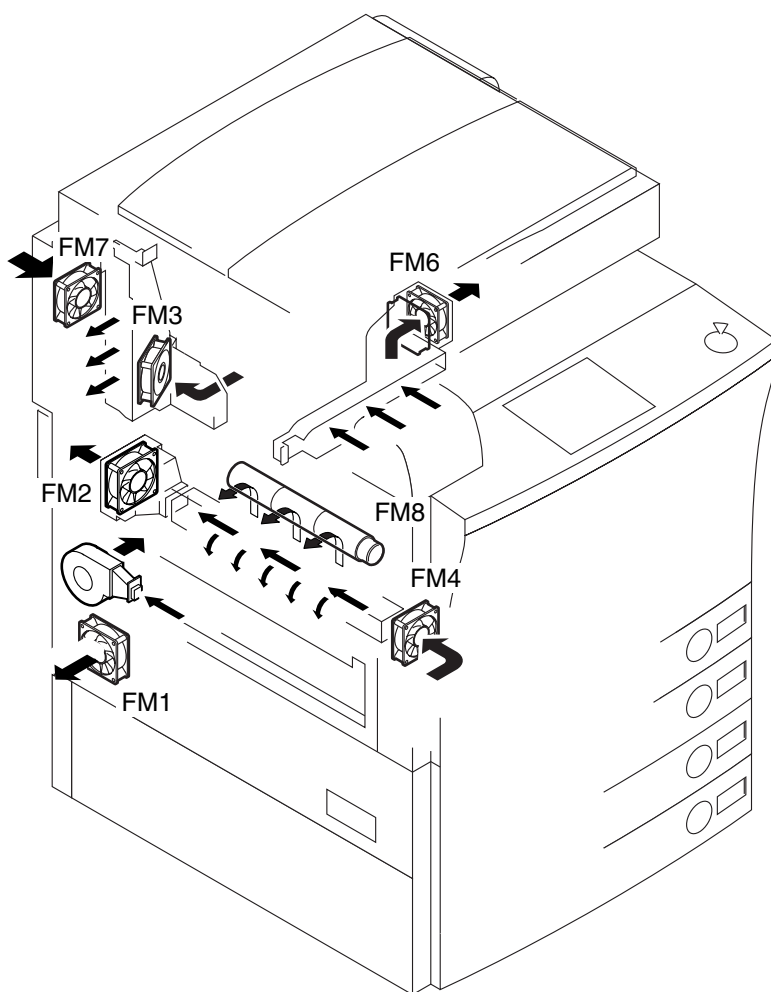

F07-301-01

3.2 Sequence of Operations (fans)

The following is the sequence of operations used by the machine to drive the fans:

When the control panel power switch is pressed to start sleep mode, the control panel LCD goes OFF. If the reading of the environment sensor is 30°C or higher at this timing, the machine rotates the fixing heat discharge fan, power supply cooling fan, and cleaner cooling fan for 30 min continuously and, thereafter, moves into sleep mode.

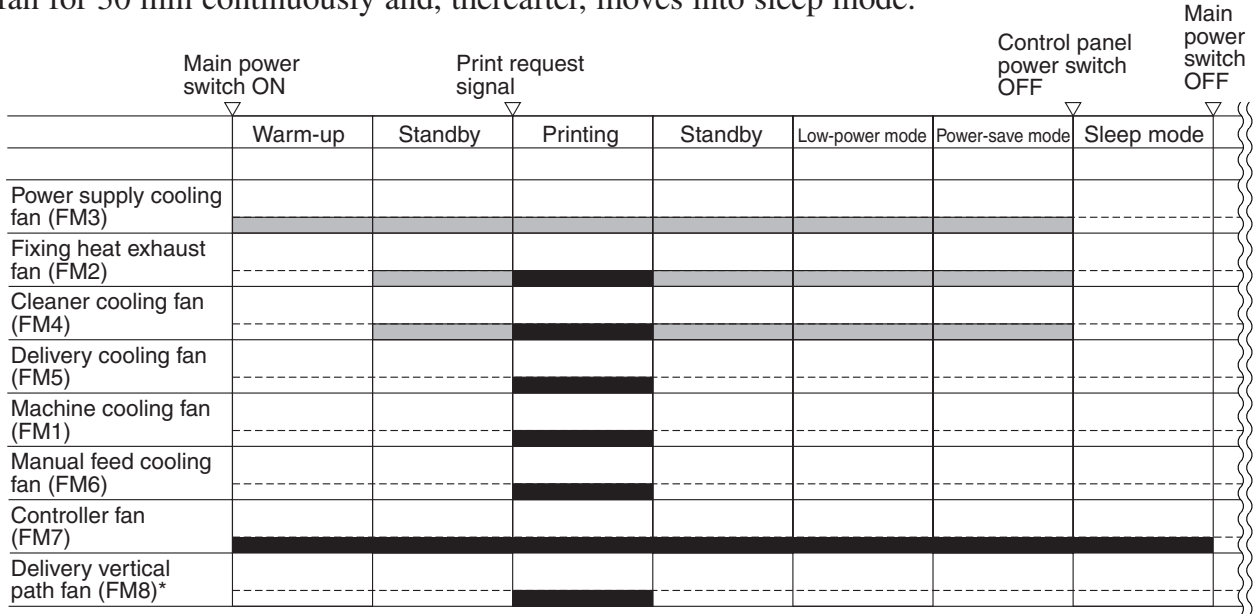

*: FM8 rotates in case either thick paper (210 to 253 g/m²) or glossy paper is fed to face-down delivery.

■: half speed. ■: full speed.

F07-302-01

4 Power Supply

4.1 Outline

4.1.1 Wiring to Various Accessories

The power supply of the printer unit and the various accessories are wired as follows:

The anti-condensation heater inside the reader unit and the power supply cable are as shown. The machine's power supply uses no more than 2 lines to connect to any external power outlet.

Pedestal	Target of reader heater power supply cable
Absent	External outlet
Present	Pedestal outlet

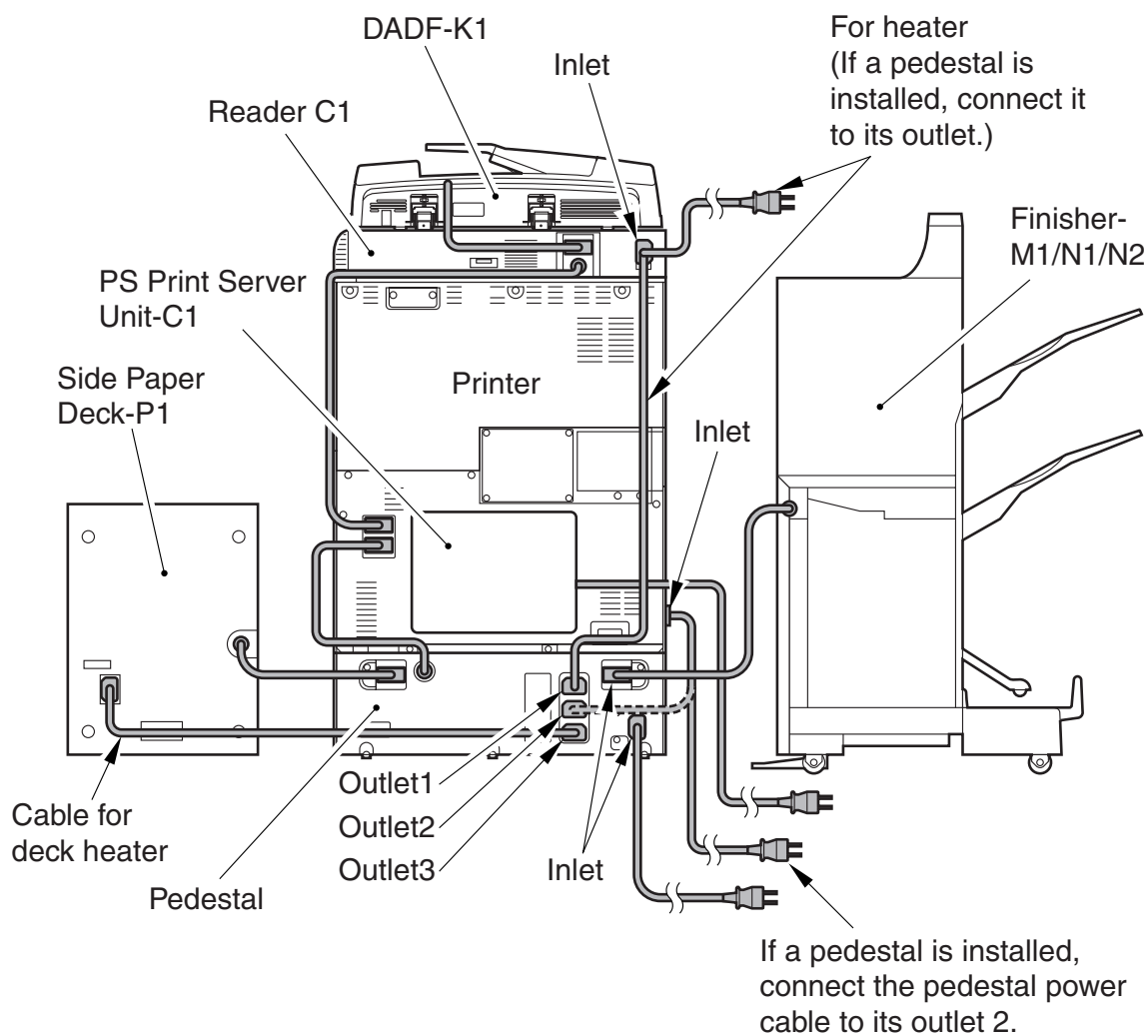

F07-401-01

4.1.2 Power Supply Route Inside the Printer Unit

The machine's DC power supply is fed with power by the 2 DC power supply PCB (DCP1, DCP2) and the DC power supply PCB (for accessories) built inside the pedestal (plain, cassette pedestal).

DC Power Supply PCB

- generates DC power from AC power
- protects against current/voltage
- supplies DC power to loads

DC Power Supply PCB for Accessories (inside pedestal)

- generates DC power from AC power
- protects against overcurrent/voltage
- supplies DC power to accessories (paper deck, finisher)

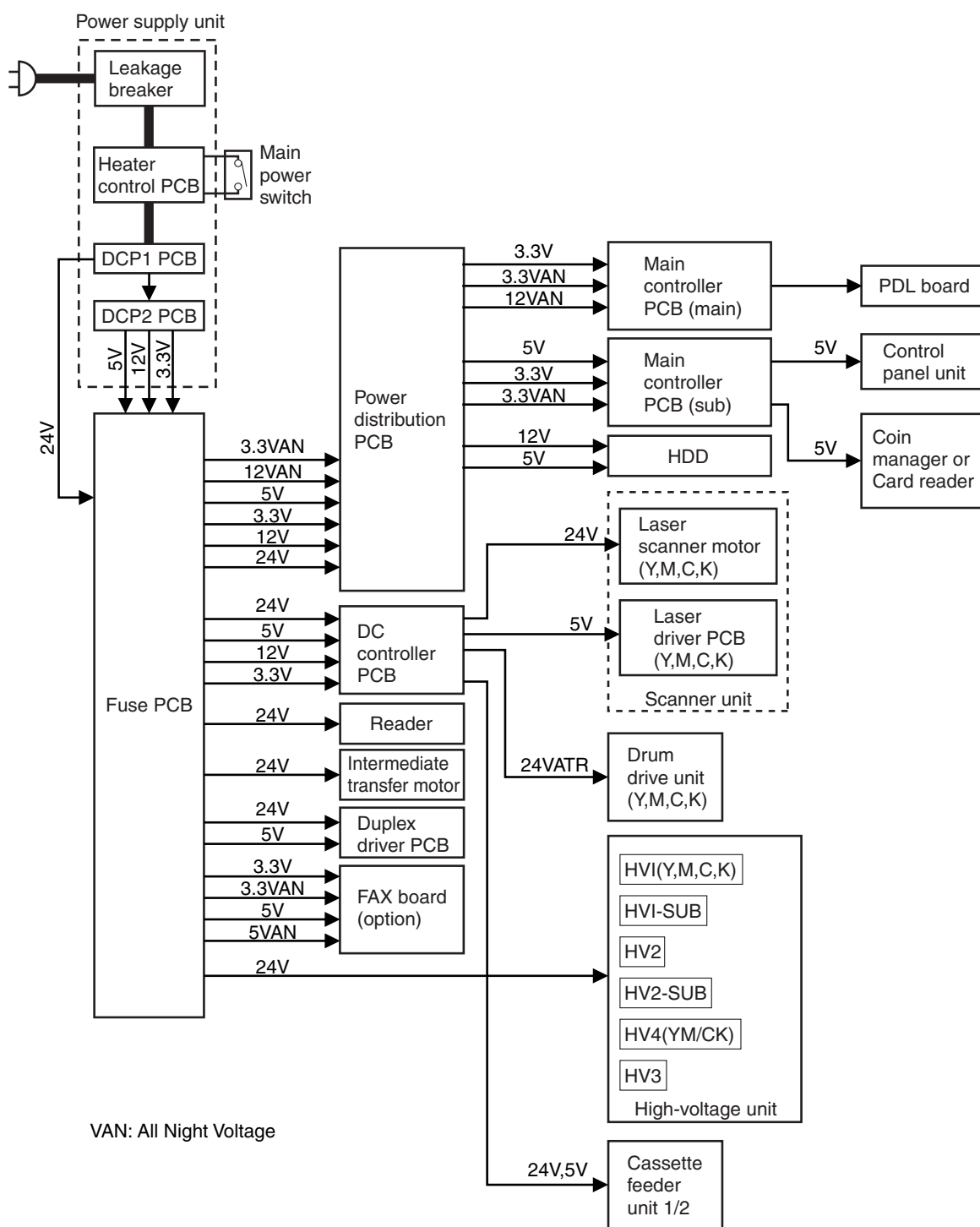

F07-401-02

4.2 Rated Output of the DC Power Supply PCB

4.2.1 Rated Output of the Machine Power Supply

The rated output and the power supply tolerance of the DC power supply PCB (DCP1 PCB, DCP2 PCB) of the printer unit are as follows:

Output	3.3 V	3.3 VAN	5 V	5 VAN	12 V	12 VAN	24 V
Tolerance	-4%/+5%	-4%/+5%	-5%/+5%	-5%/+5%	-8%/+10%	-9%/+10%	-9%/+10%

4.2.2 Rated Output of the Pedestal DC Power Supply

The rated output and the power supply tolerance of the pedestal DC power supply PCB are as follows:

Output	5 V	24VAN
Power supply tolerance	-5%/+5%	-10%/+10%

4.3 Protective Mechanisms

The machine's power supply PCB and the power supply PCBs of its accessories are equipped with an overcurrent/voltage protective mechanisms that prevent damage to the power supply circuit by automatically cutting off the output voltage in the event of an overcurrent/voltage caused, for example, by a short-circuit in any of its loads.

If the protective function has gone ON, turn off the power switch of the printer unit, disconnect the power plug of the printer unit or the accessories power supply circuit, and remove the cause of activation; then, leave the machine alone for about 3 min, and turn it on to reset.

4.4 Backup Power Supply

The SRAM PCB and the DC controller PCB of the machine's main controller PCB are each equipped with a lithium battery for backup in the event of a power outage or disconnection of the power plug.

SRAM PCB	manganese dioxide/lithium battery (3 V, 1000 mAh)
DC controller PCB	lithium battery (3 V, 560 mAh)
Battery life	10 yr or more (for both; with power plug disconnected)
Battery replacement	not possible (on its own, in the field)
After replacement of battery in workshop	input of values indicated on service label



The lithium battery must be replaced only with the one indicated in the Parts Catalog; otherwise, it may trigger a fire or explosion.

Do not charge, disassemble, or incinerate the lithium battery; mishandling can lead to a fire or a chemical explosion.

Keep the lithium battery out of reach of children. Be sure to dispose of a used battery strictly in accordance with all applicable regulations.

4.5 Power Save Functions

4.5.1 Outline

1. Standby Mode

In standby mode, the machine is in operation or is ready to operate, with all its parts supplied with power.

2. Power-Save Mode

The term 'power-save mode' is used generically to refer to the following modes, in which the machine is supplied with power differently than it is in normal mode: power-save, low-power, sleep. A shift in the direction of 'present power-save mode' to 'low-power mode' and then to 'sleep' mode occurs automatically.

- Power-Save Mode

Shift: A shift to power-save mode is initiated only in response to a press on the Save Power button on the control panel.

Description: The power used by the machine is reduced according to the settings made in user mode (immediate recovery, -10%, -25%, -50%; the fixing unit is controlled to 190°C).

- Low-Power Mode (factory setting)

This mode conforms to the standards under Energy Star.

Shift: A shift is made only in response to the passage of time (auto low-power shift time) selected in user mode.

Description: The power used by the machine is reduced to enable the machine to remain in a state that satisfies the standards under Energy Star.

The power supplied to the reader unit will remain ON except the +24V power, which the reader unit uses to generate internal power. (All operations remain at rest.)

The printer unit keeps the temperature of the fixing unit to a specific level (190°C) which is lower than when the machine is in normal operating mode.

- Sleep Mode (sleep mode 1 or sleep mode 2)

Shift: A shift is made in response to the passage of time (auto sleep shift time) specified in user mode or in response to a press on the control panel software power switch.

Description: In sleep mode 1 (relatively higher power consumption), the fixing assembly is totally deprived of power. The DC controller PCB, however, remains supplied with power.

In sleep mode 2 (relatively lower power consumption), on the other hand, the printer unit (including the fixing assembly) remains OFF; the main controller PCB is supplied with all-night power as indicated in the table:

Controller	+3.3 VAN	CPU, main memory
	+12 VAN	controller cooling fan
FAX	+5 VAN	fax arrival detection

T07-405-01

3. AC OFF Mode

AC OFF mode occurs when the main power switch is turned off, i.e., all parts of the machine is deprived of power.

The supply of power to the various systems of the machine in each of the foregoing modes is as follows:

			Standby mode	Power-save mode	Low-power mode	Sleep mode 1	Sleep mode 2	AC OFF mode
Main controller	Non-all night power	+12V	ON	ON	ON	ON	OFF	OFF
		+5V	ON	ON	ON	ON	OFF	OFF
		+3.3V	ON	ON	ON	ON	OFF	OFF
	All-night power	+3.3VAN	ON	ON	ON	ON	ON	OFF
+12VAN		ON	ON	ON	ON	ON	OFF	
Reader unit		+24V	ON	OFF	OFF	OFF	OFF	OFF
Printer unit		+24V	ON	ON	ON	ON	OFF	OFF
		+12V	ON	ON	ON	ON	OFF	OFF
		+5V	ON	ON	ON	ON	OFF	OFF
		+3.3V	ON	ON	ON	ON	OFF	OFF
FAX	Non-all night power	+5V	ON	ON	ON	ON	OFF	OFF
		+3.3V	ON	ON	ON	ON	OFF	OFF
	All-night power	+5VAN	ON	ON	ON	ON	ON	OFF

T07-405-02

5 Disassembly and Assembly

5.1 Removing the Fixing Drive Unit

- 1) Remove the fixing heat exhaust fan.
(See 5.18 'Removing the Fixing Heat Exhaust Fan.')
- 2) Remove the secondary transfer high-voltage unit. (See 5.3.2 'Removing the Secondary Transfer High-Voltage Unit.')
- 3) Slide out the fixing feeder assembly. Disconnect the connector [1], and remove the 3 screws [2]; then, detach the fixing drive unit [3].

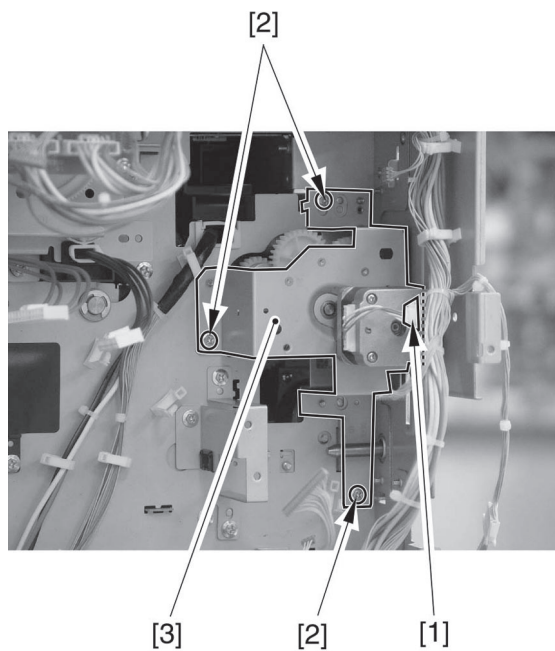

F07-501-01

5.2 Removing the High-Voltage Unit

- 1) Remove the upper rear cover and the lower rear cover.
- 2) Disconnect all connectors of the high-voltage unit; then, remove the 5 screws [1], and detach the high-voltage unit [2].

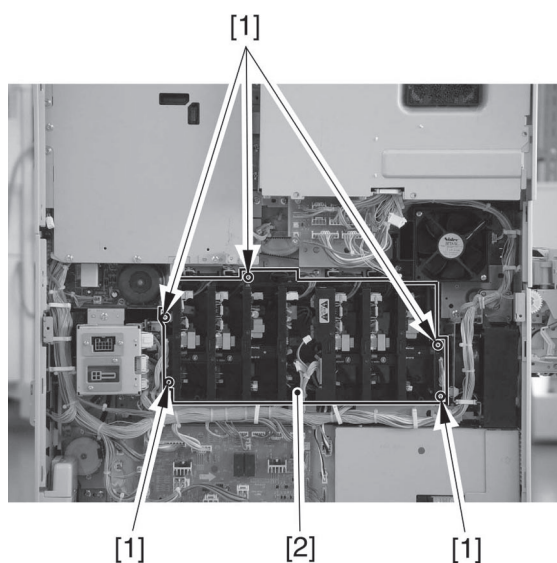

F07-502-01

- 2) Remove the 6 screws [1], and remove the base plate [2]; then, detach the high-voltage unit [3].

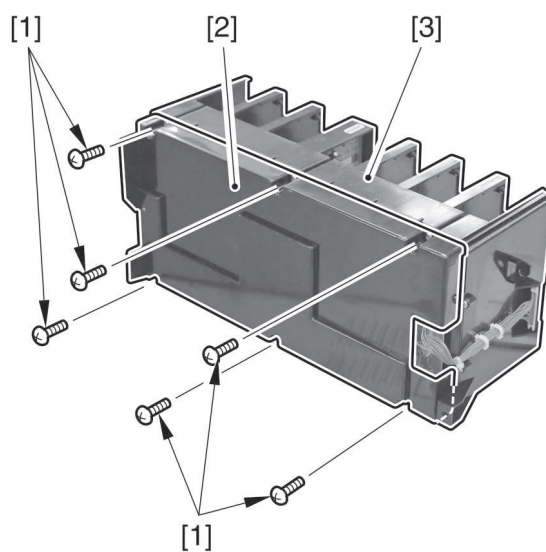

F07-502-02

5.3 Removing the Secondary Transfer High-Voltage Unit

- 1) Remove the high-voltage unit. (See 5.2 'Removing the High-Voltage Unit.)
- 2) Remove the left lower rear cover.
- 3) Free the DC harness [1] from the edge saddle [2]; then, disconnect the 3 connectors [3], and remove the 2 screws [4].

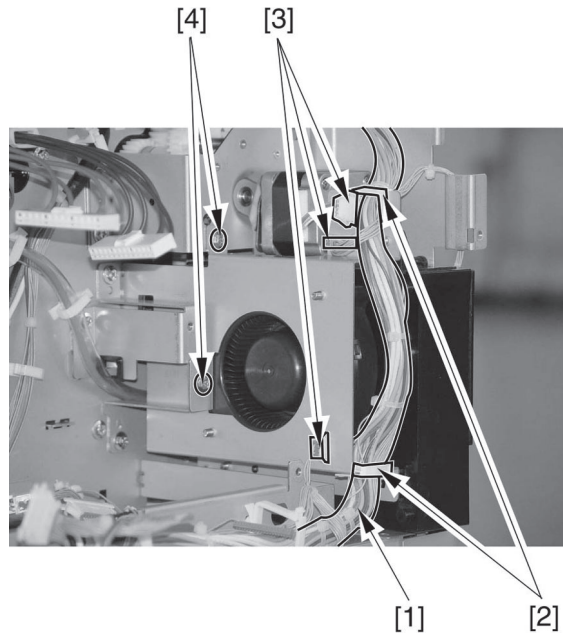

F07-503-01

- 4) Remove the mounting screw [1] of the high-voltage cable, and free the high-voltage cable [2] from the cable clamp [3]; then, detach it from the edge saddle [4] of the high-voltage unit base.

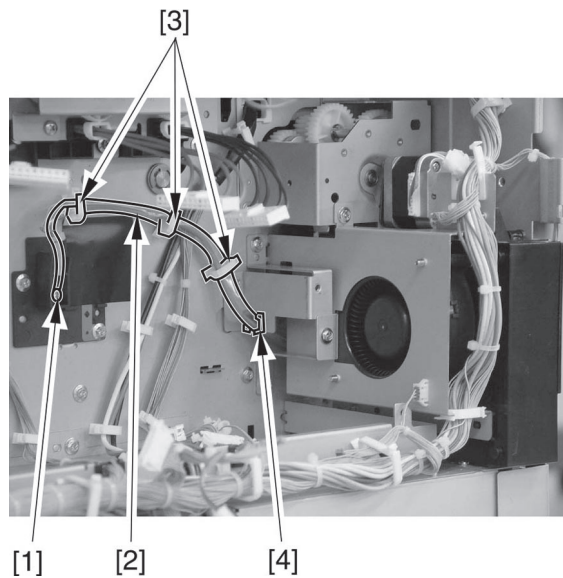

F07-503-02

- 5) Pull the secondary transfer high-voltage unit [1] slightly to the front, and free the high-voltage cable [3] from the cable clamp [2].

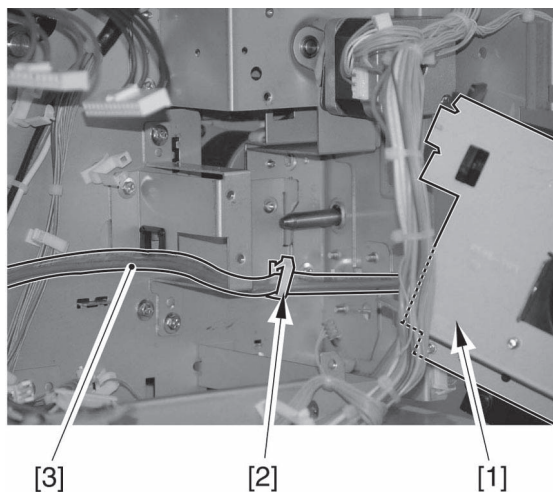

F07-503-03

- 6) Remove the secondary transfer high-voltage unit together with the delivery cooling fan.
- 7) Remove the screw [1], and disconnect the connector [2]; then, detach the secondary transfer high-voltage unit [3].

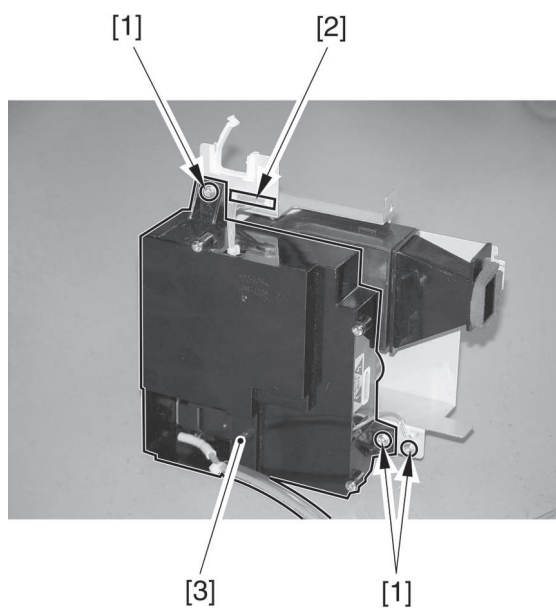

F07-503-04

5.4 Removing the Developing Drive Unit

- 1) Open the main controller box. (See 5.26 'Removing the Relay PCB 1.')
- 2) Remove the DC controller PCB together with its base. (See 5.21 'Removing the DC Controller PCB.')
- 3) Remove the fixing heat exhaust fan. (See 5.18 'Removing the Fixing Heat Exhaust Fan.')
- 4) Remove the heat exhaust fan unit. (See 5.19 'Removing the Heat Exhaust Fan Unit.')
- 5) Disconnect the connector [2] of the developing motor [1], and free the harness [3] from the cable clamp [4].

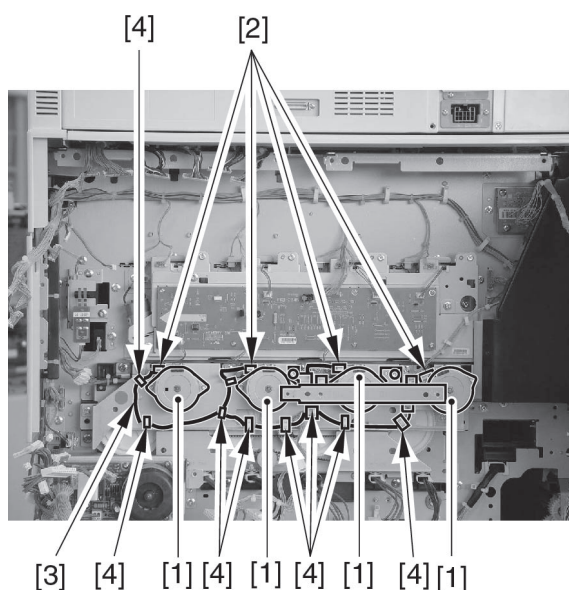

F07-504-01

- 6) Remove the 2 screws [1], and detach the main controller base [2].

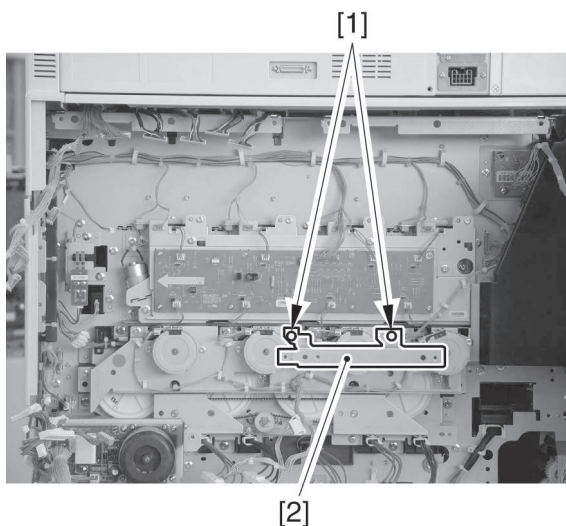

F07-504-02

- 7) Remove the 7 screws [1], and detach the developing drive assembly [2].

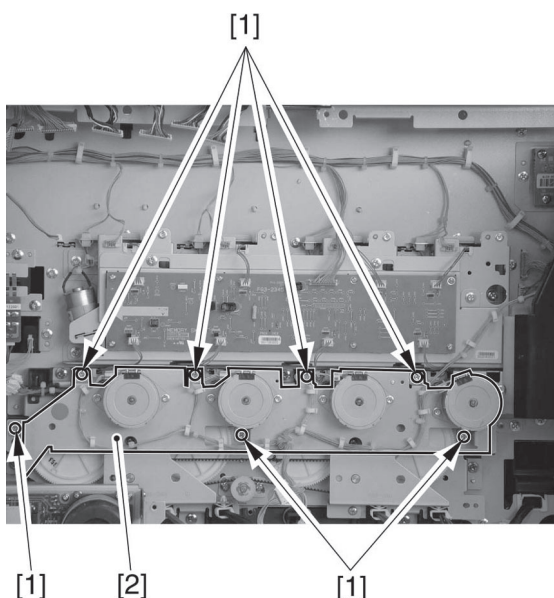

F07-504-03

5.5 Removing the Fixing Motor

- 1) Remove the fixing drive unit. (See 5.1 'Removing the Fixing Drive Unit.')
- 2)



When mounting the fixing motor to the motor base, be sure that the connector [2] of the motor [1] is located as shown.

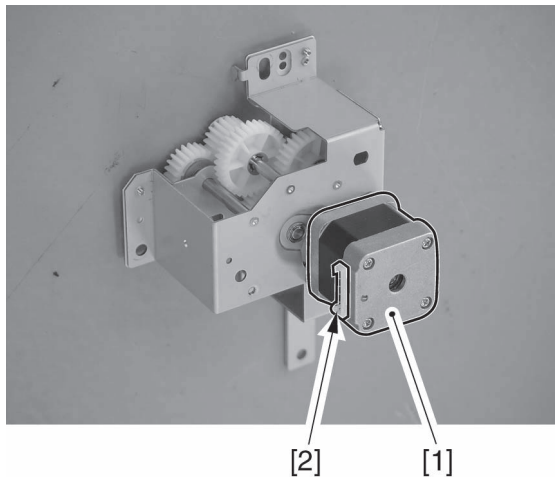

F07-505-01

Remove the tension spring [1] and the 3 screws [2] found inside the fixing drive assembly; then, detach the fixing motor [3].

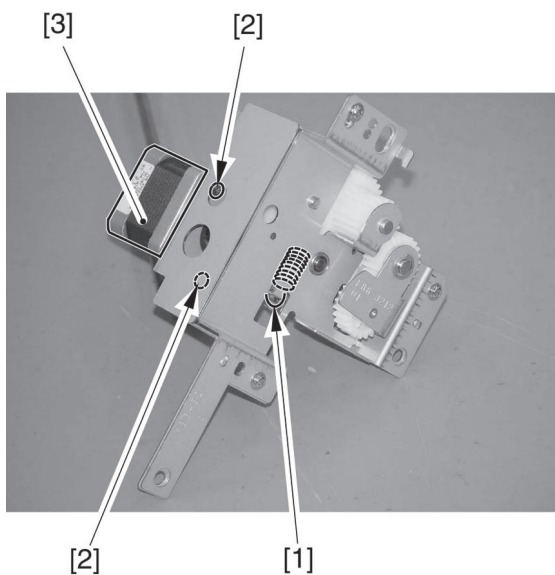

F07-505-02

5.6 Remove the DC Power Supply Unit

- 1) Remove the rear upper cover and the rear lower cover.
- 2) Remove the 2 screws [1], and disconnect all connectors of the fuse PCB; then, detach the DC power supply unit [2].

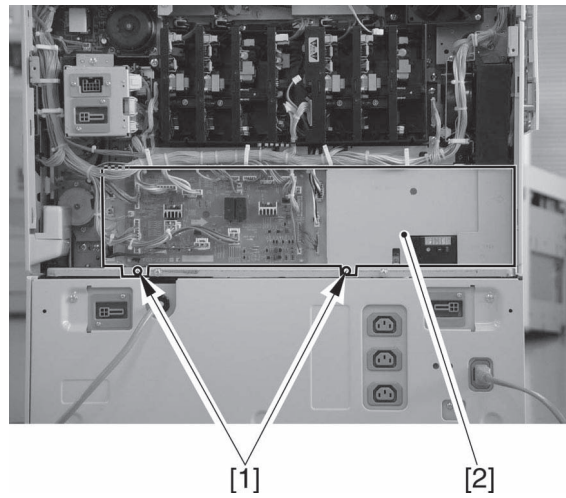

F07-506-01

5.7 Removing the Control Panel

- 1) Remove the upper left cover (small).
- 2) Remove the inside cover.
- 3) Remove the 4 screws [1], and detach the control panel [2] toward the front.

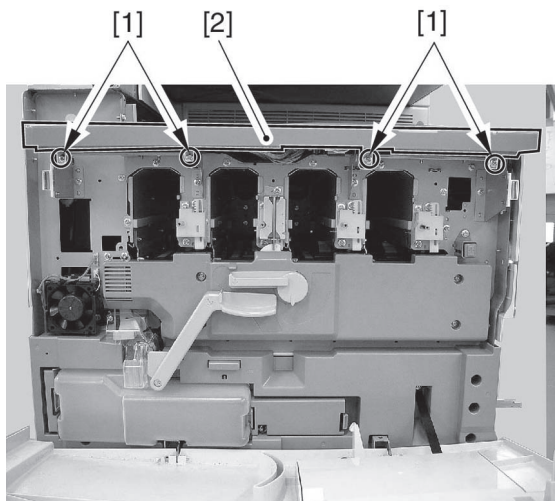

F07-507-01

- 4) Disconnect the connector [1], and detach the control panel [2].

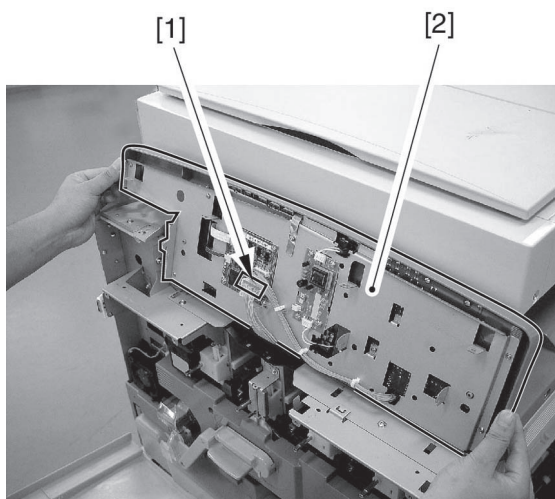

F07-507-02

5.8 Removing the Control Panel Key PCB

- 1) Remove the control panel. (See 5.7 ‘Removing the Control Panel.’)
- 2) Disconnect the 3 connectors [1] from the CPU PCB, remove the 2 flat cables [2], disconnect the 2 connectors [3] from the inverter PCB, remove the binding screw [4], and remove the 8 self-tapping screws [5]; then, detach the control panel back plate [6].

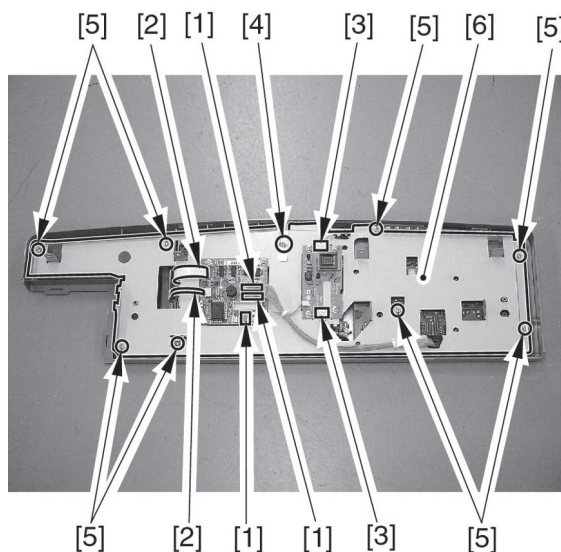

F07-508-01

- 3) Remove the 7 screws [1], and detach the control panel key PCB [2].

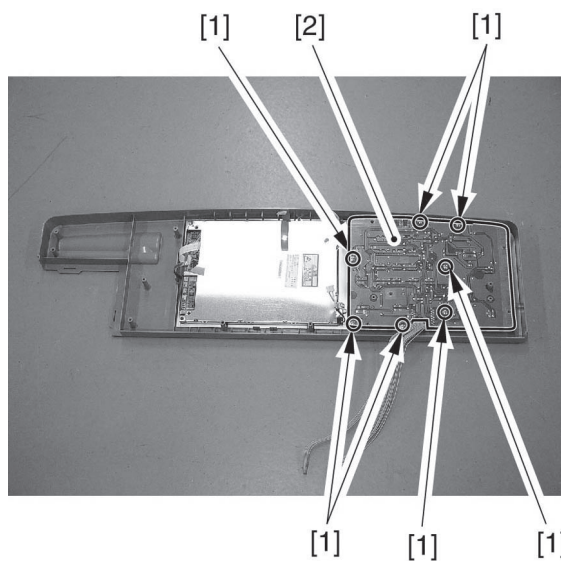

F07-508-02

5.9 Removing the Control Panel CPU PCB

- 1) Remove the control panel. (See 5.7 ‘Removing the Control Panel.’)
- 2) Disconnect the 3 connectors [1], and remove the 2 flat cables [2]; then, detach the control panel CPU PCB [4].

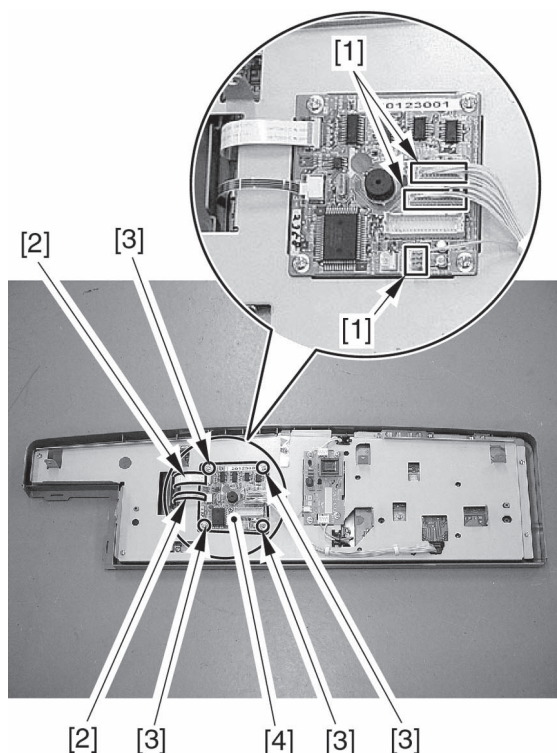

F07-509-01

5.10 Removing the Control Panel Inverter PCB

- 1) Remove the control panel. (See 5.7 'Removing the Control Panel.')
- 2) Disconnect the 3 connectors [1], and remove the 4 screws [2]; then, detach the control panel inverter PCB [3].

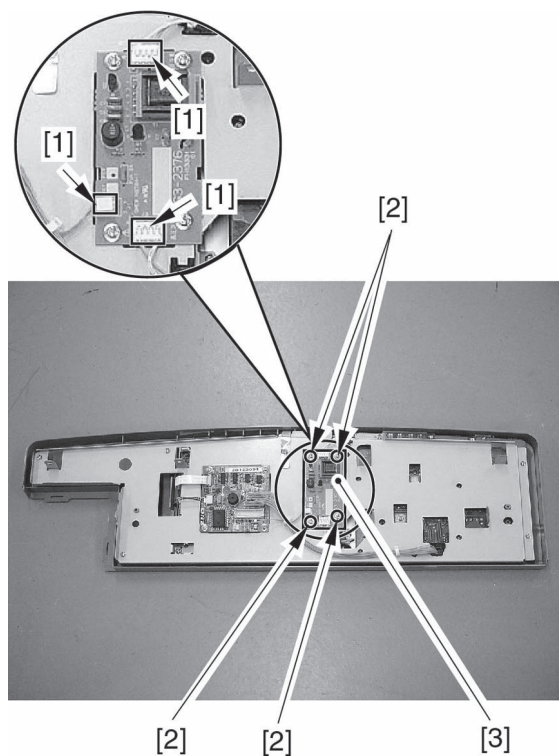

F07-510-01

5.11 Removing the Control Panel LCD Unit

- 1) Remove the control panel. (See 5.7 'Removing the Control Panel.')
- 2) Remove the control panel PCB.
- 3) Remove the 3 screws [1], and detach the control panel LCD unit [2].

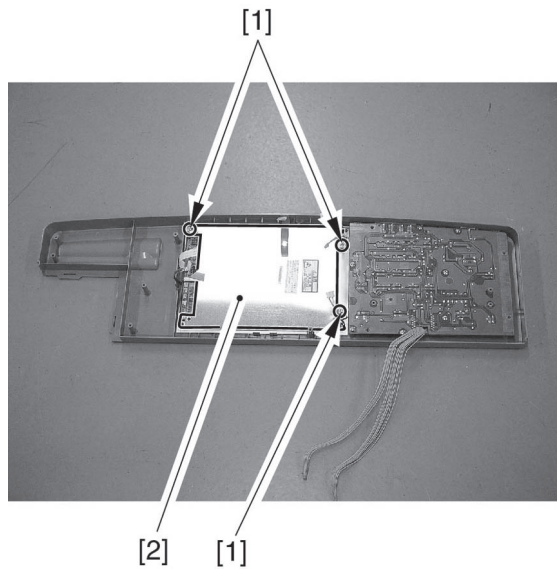

F07-511-01

5.12 Removing the Main Power Supply Switch

- 1) Remove the manual feed cooling fan duct. (See 5.17 'Removing the Manual Feed Cooling Fan.')
- 2) Remove the 2 terminals [1].

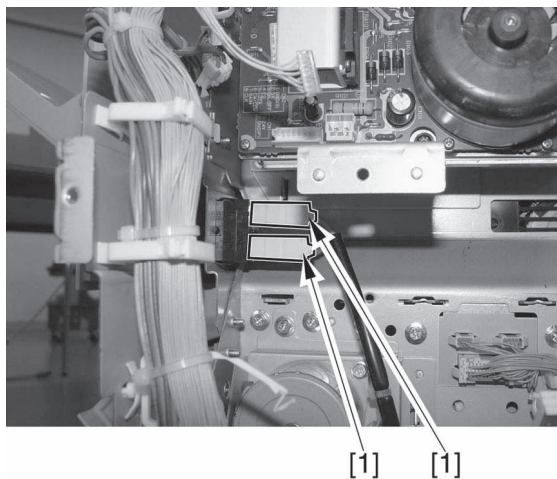

F07-512-01

- 3) Pick the stopper segment [A], and detach it.

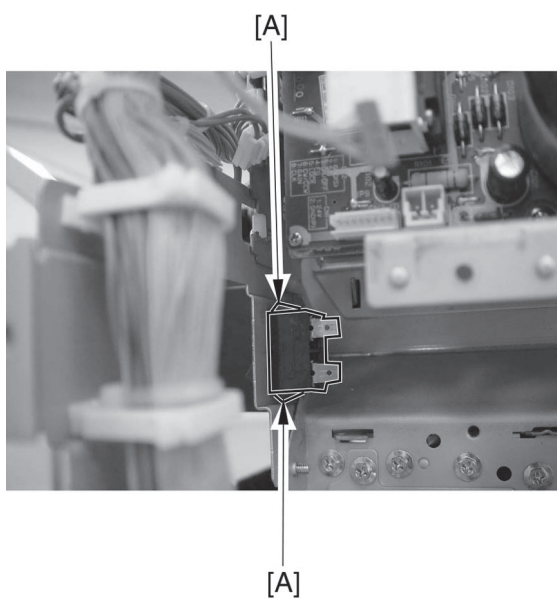

F07-512-02

5.13 Removing the Front Cover Open/Close Switch

- 1) Open the front cover.
- 2) Remove the 4 screws [1], and detach the 4 toner container releasing levers [2].

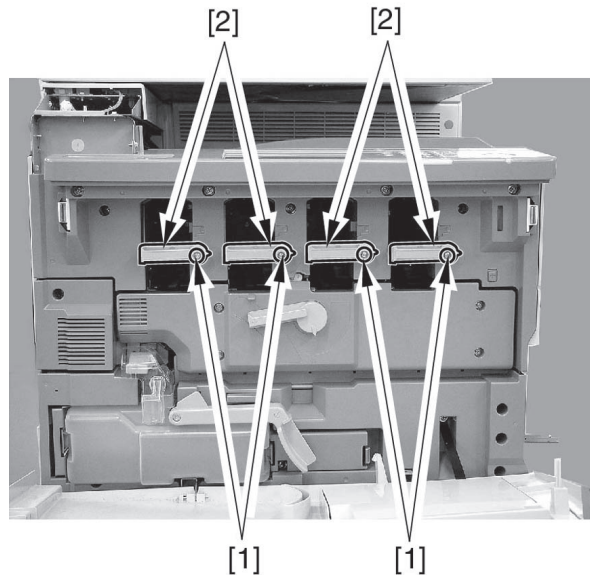

F07-513-01

- 3) Detach the cleaner fan cover.

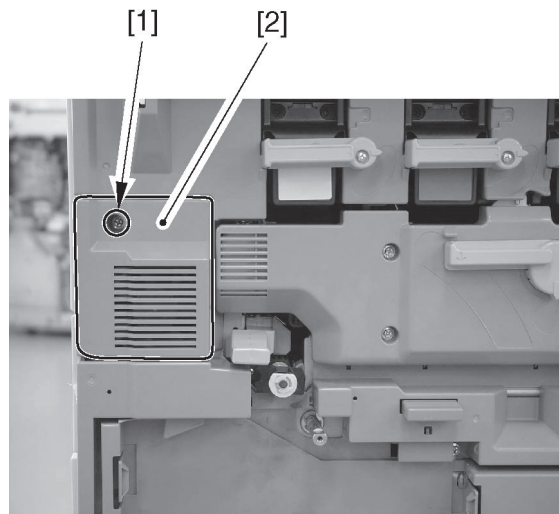

F07-513-02

- 4) Open the drum unit cover.
- 5) Remove the 5 screws [1], and detach the inside cover [2].

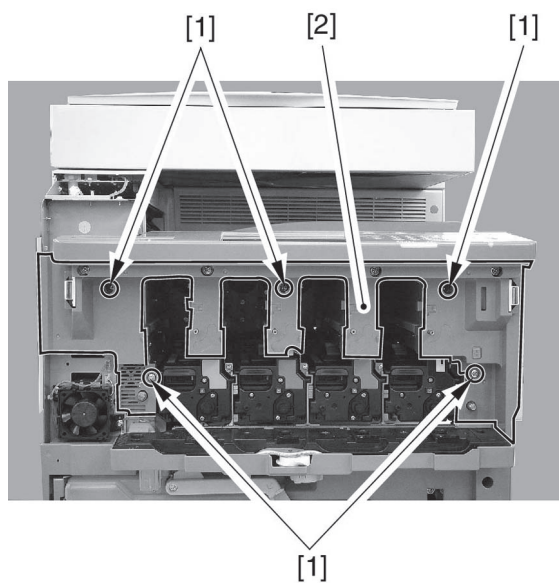

F07-513-03

- 6) Remove the screw [1], and detach the retaining plate [2]; then, push it inside the front side cover.

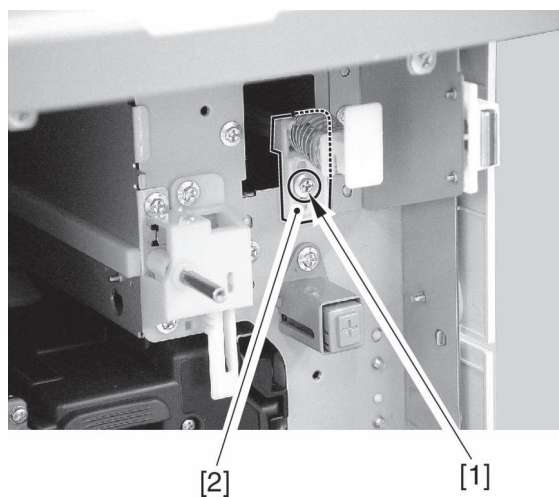

F07-513-04

- 7) Remove the upper rear cover and the lower rear cover.
- 8) Remove the DC controller base.
- 9) Disconnect the 2 connectors [1], and remove the 2 screws [2]; then, slide out the sensor base [3]. (The sensor flag pushing plate is found running from the front side plate to the rear side plate.)

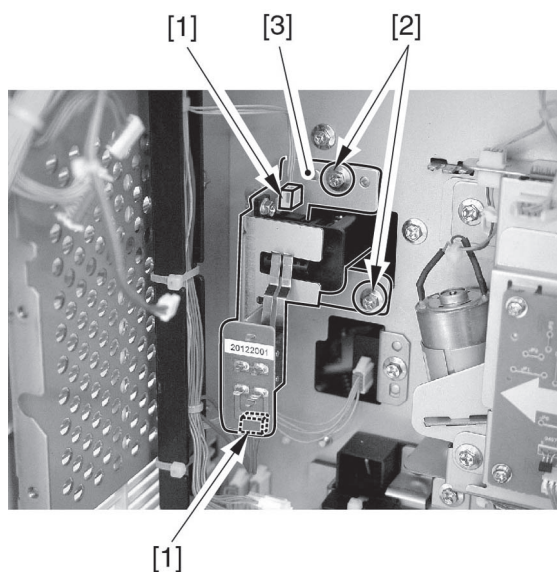

F07-513-05

- 10) Remove the screw [1], and detach the front cover open/close switch [2].

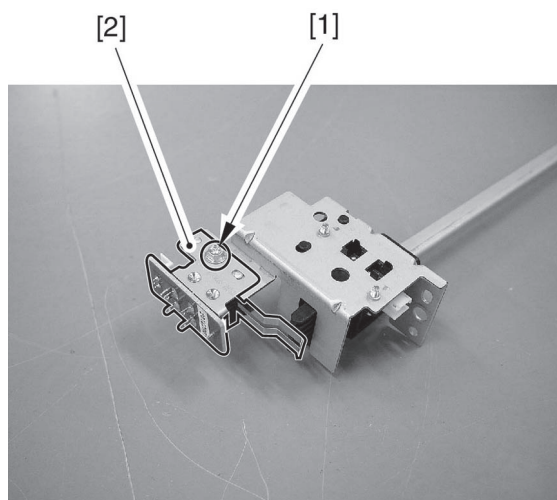

F07-513-06

5.14 Removing the Front Cover Open/Closed Sensor

- 1) Open the front cover.
- 2) Remove the 4 screws [1], and detach the 4 toner container releasing levers [2].

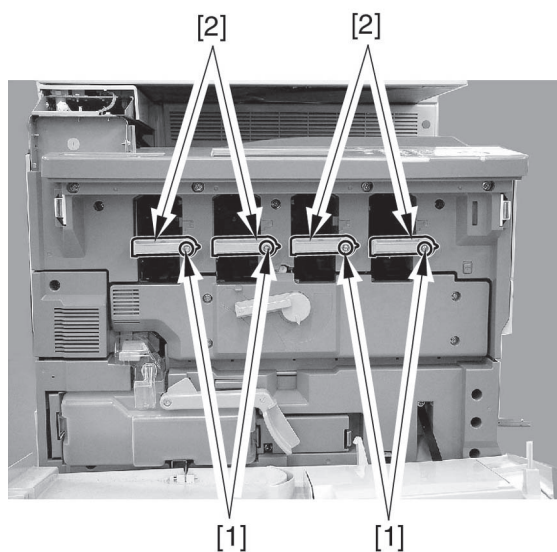

F07-514-01

- 3) Remove the cleaner fan cover.

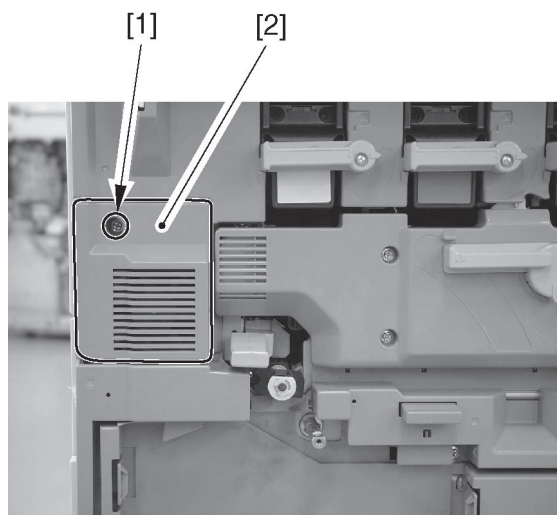

F07-514-02

- 4) Open the drum unit cover.
- 5) Remove the 5 screws [1], and detach the inside cover [2].

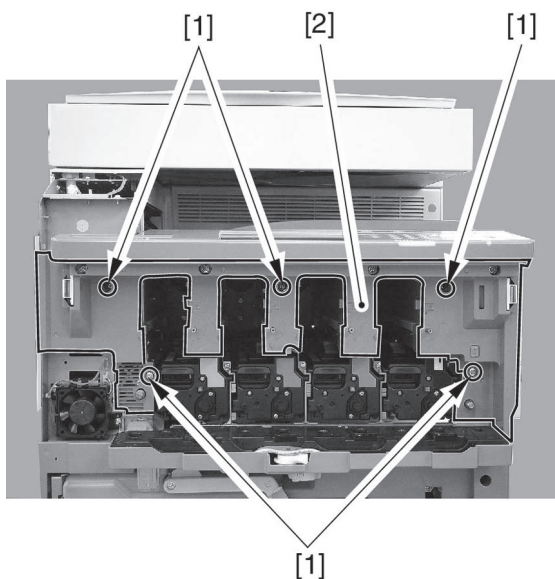

F07-514-03

- 6) Remove the screw [1], and remove the retaining plate [2]; then, push it inside the front side plate.

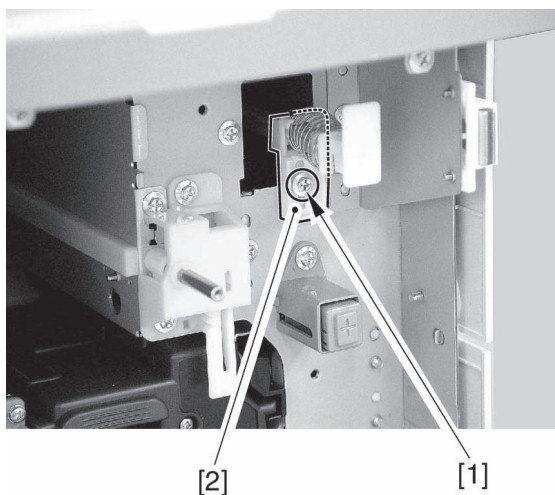

F07-514-04

- 7) Remove the upper rear cover and the lower rear cover.
- 8) Remove the DC controller base.
- 9) Disconnect the 2 connectors [1], and remove the 2 screws [2]; then, slide out the sensor base [3].
(The sensor flag pushing plate is found running from the front side plate to the rear side plate.)

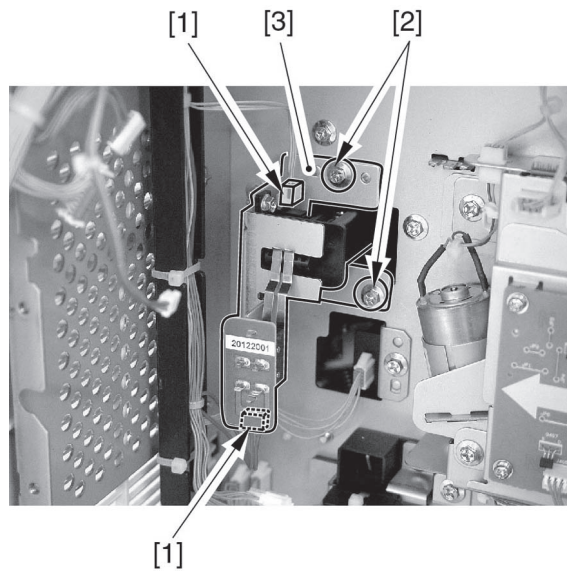

F07-514-05

- 10) Remove the 2 screws [1], and detach the sensor cover [2].

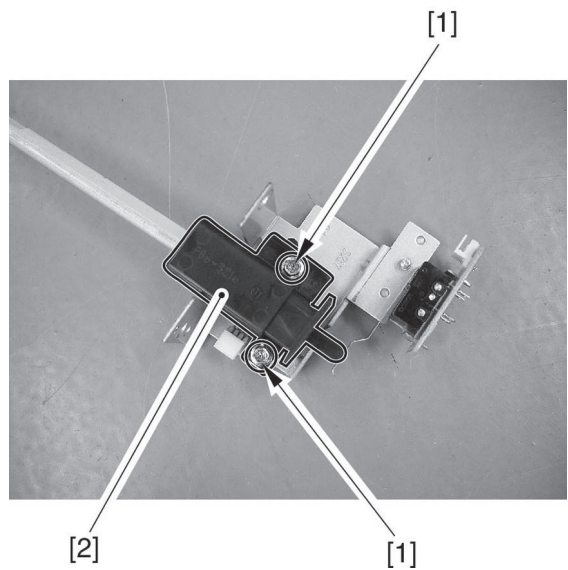

F07-514-06

- 11) Remove the front cover open closed sensor [1].

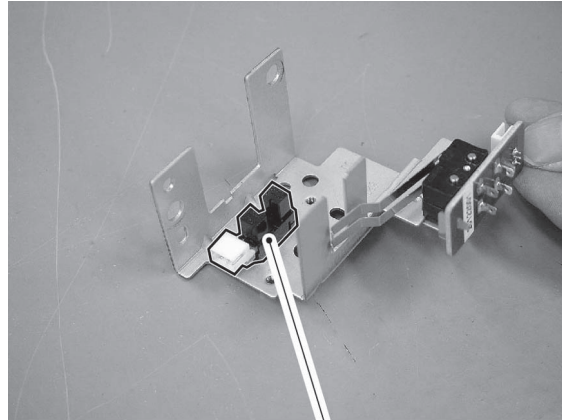

[1]

F07-514-07

5.15 Removing the Manual Feed Unit Open/Closed Sensor

- 1) Open the main controller box. (See 5.26 'Removing the Relay PCB 1.')
- 2) Detach the DC controller PCB together with its base. (See 5.21 'Removing the DC Controller PCB.')
- 3) Disconnect the 2 connectors [1], and remove the screw [2]; then, detach the registration unit open/closed sensor base [3].

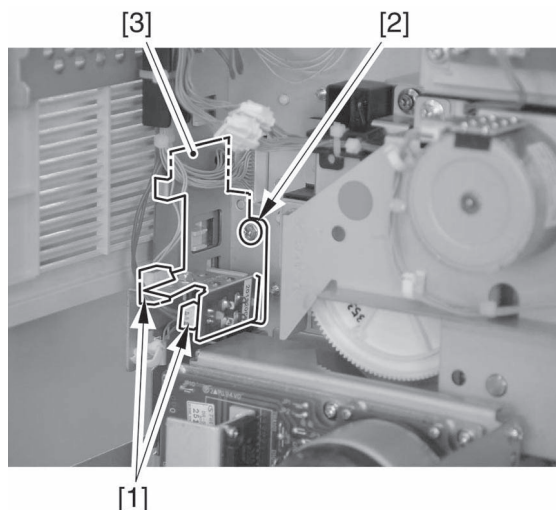

F07-515-01

- 4) Disconnect the connector [1], and remove the registration unit open/closed sensor [2].

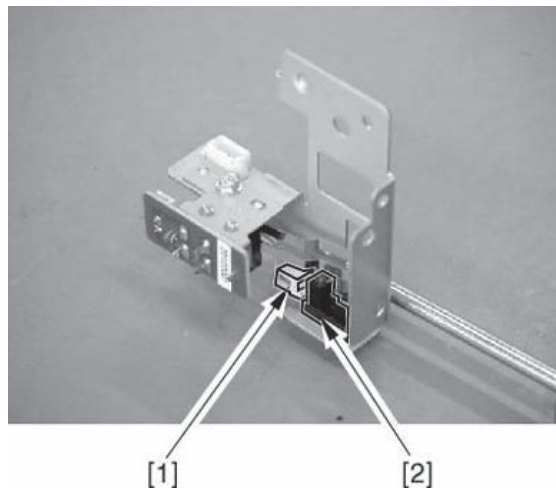

F07-515-02

5.16 Removing the Manual Feed Unit Open/Close Switch

- 1) Open the main controller PCB. (See 5.26 'Removing the Relay PCB 1.')
- 2) Remove the DC controller PCB together with its base. (See 5.21 'Removing the DC Controller PCB.')
- 3) Disconnect the 2 connectors [1], and remove the 2 screws [2]; then, detach the manual feed unit open/closed sensor base [3].

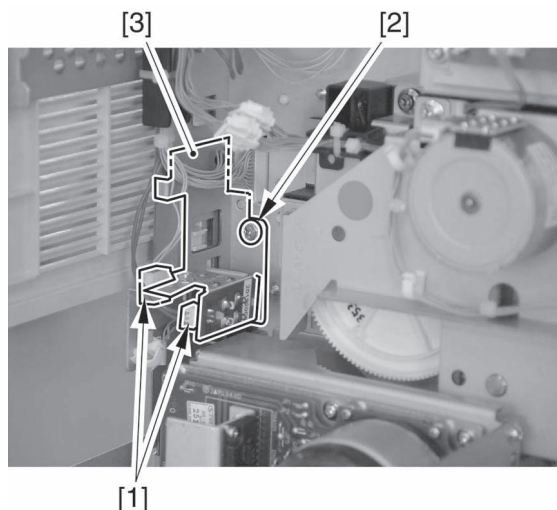

F07-516-01

- 4) Remove the screw [1], and detach the manual feed unit open/close switch [2].

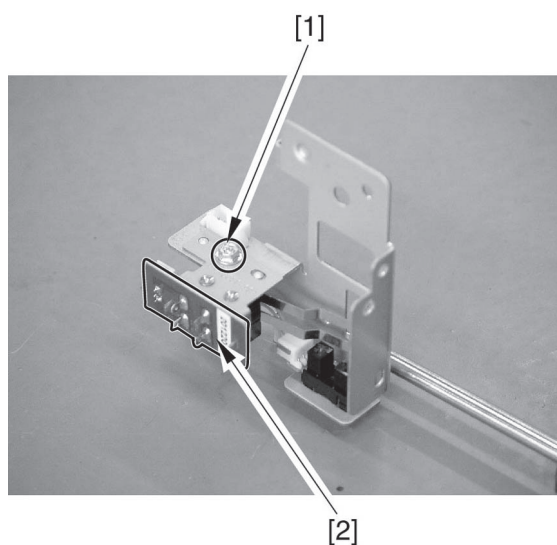

F07-516-02

5.17 Removing the Manual Feed Cooling Fan

- 1) Remove the drum drive unit. (See 6.19 ‘Removing the Drum Drive Unit’ in Chapter 4.)
- 2) Disconnect the connector [1], and remove the 2 screws [2]; then, detach the manual feed cooling fan duct [3].

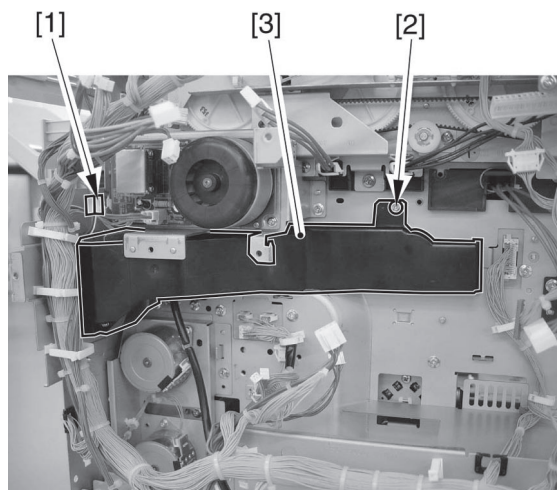

F07-517-01

- 3) Remove the 2 screws [1], and detach the manual feed cooling fan [2].

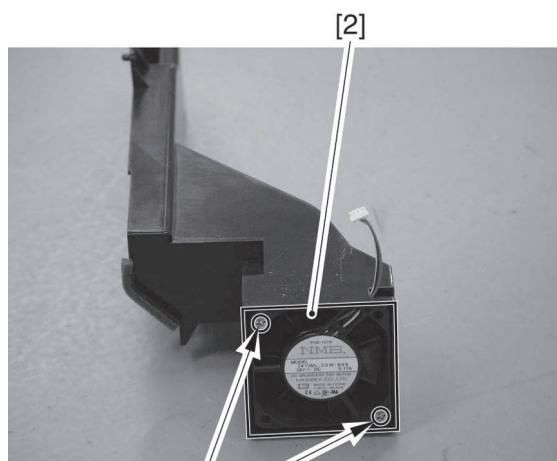

[1]

F07-517-02

5.18 Removing the Fixing Heat Exhaust Fan

- 1) Open the main controller box. (See 5.26 'Removing the Relay PCB 1.')
- 2) Remove the 2 screws [1], and disconnect the connector [2]; then, detach the fixing heat exhaust fan [3].

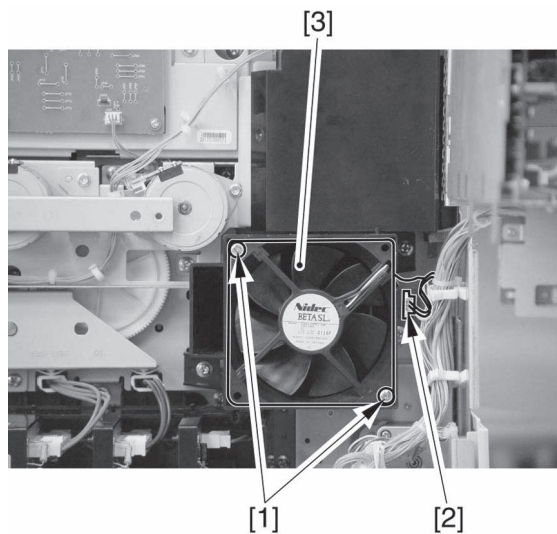

F07-518-01

5.19 Removing the Heat Discharge Fan Unit

- 1) Open the main controller box. (See 5.26 'Removing the Relay PCB 1.')
- 2) Remove the screw [1], and detach the fan duct [2].

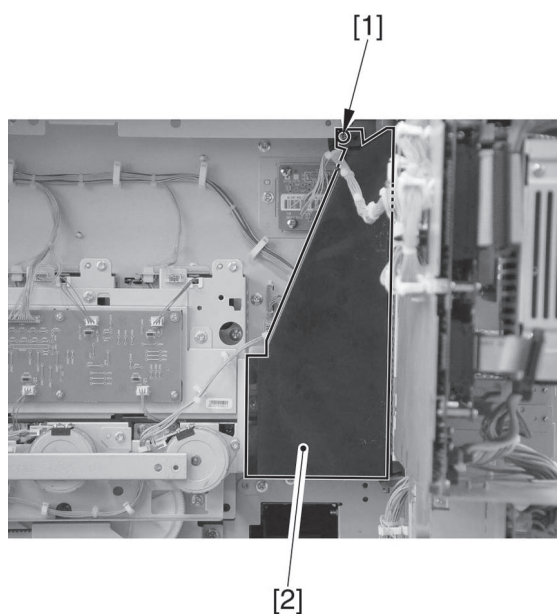

F07-519-01

- 3) Remove the 2 screws [1], and disconnect the connector [2]; then, detach the heat exhaust fan unit [3].

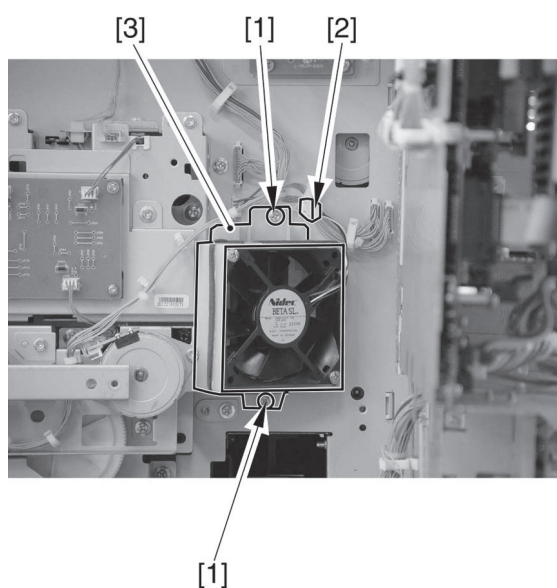

F07-519-02

5.20 Removing the Heat Discharge Fan

- 1) Remove the main controller box. (See 5.26 'Removing the Rely PCB 1.')
- 2) Remove the screw [1], and detach the fan duct [2].

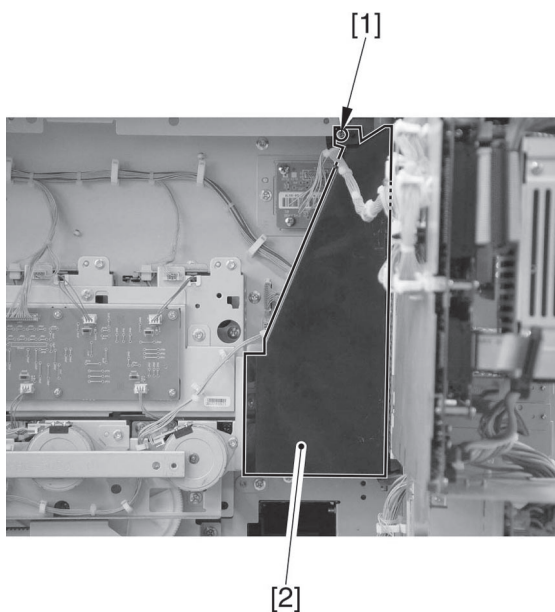

F07-520-01

- 3) Remove the 2 screws [1], and disconnect the connector [2]; then, detach the heat exhaust fan [3].

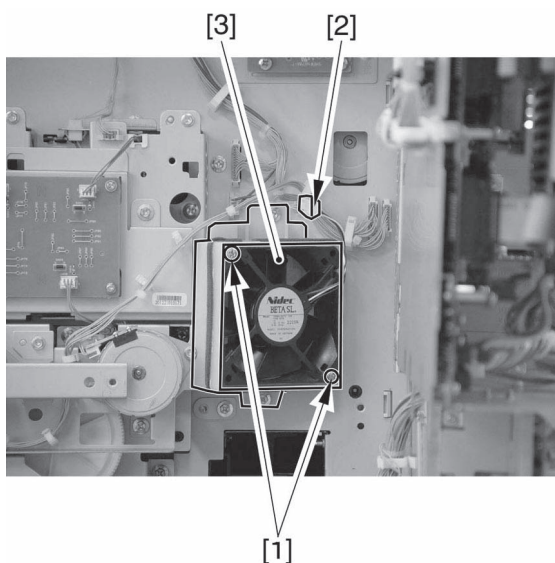

F07-520-02

5.21 Removing the DC Controller PCB

- 1) Remove the upper rear cover and the lower rear cover.
- 2) Disconnect the connector J1512 [1] from the power distribution PCB, and free the harness from the wire saddle [2]; then, remove the 6 screws [3], and detach the main controller cover [4].

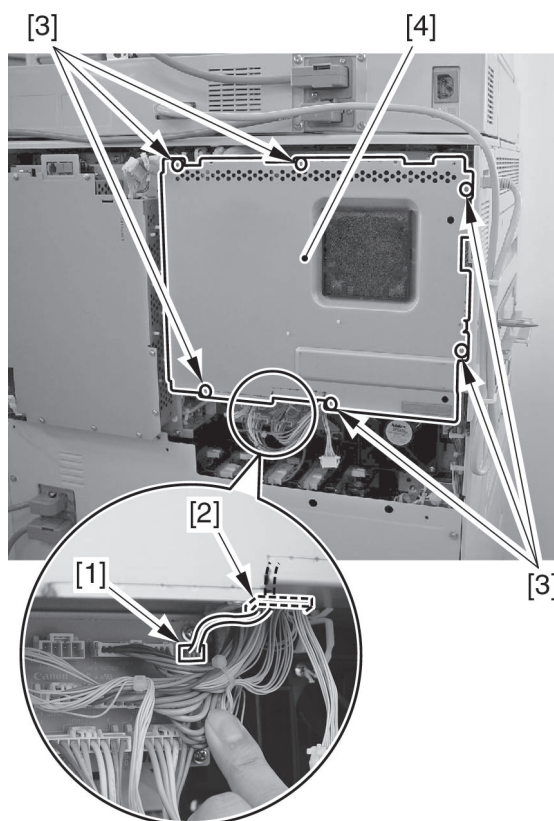

F07-521-01

- 3) Remove the 8 screws [1], and detach the DC controller PCB cover [2].

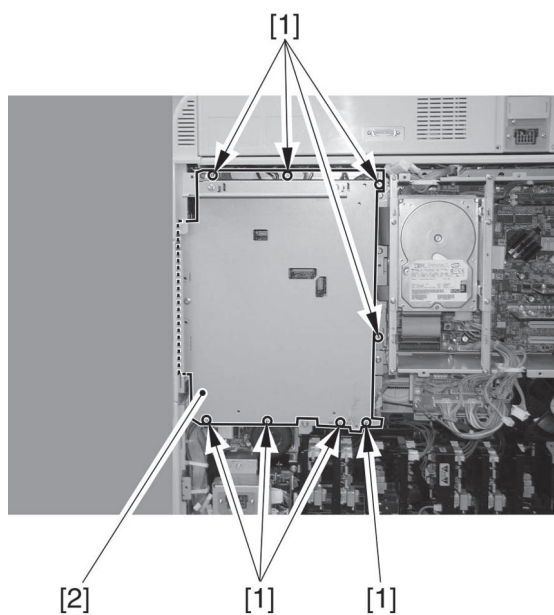

F07-521-02



When attaching the cover, take care so that the cut-off will not come into contact with the latch of the flat cable. Otherwise, the flat cable can come loose.

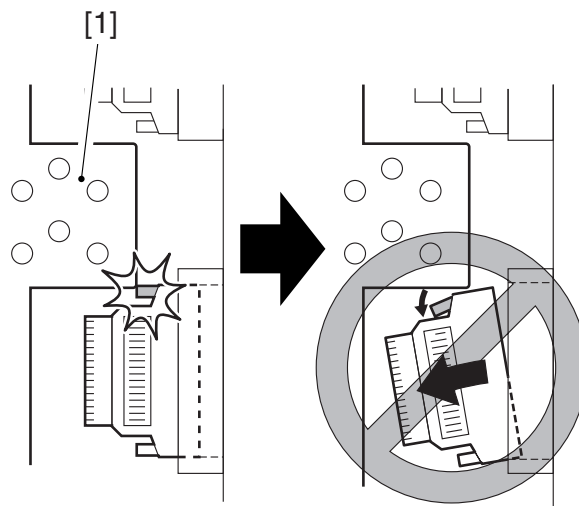

F07-521-03

- 4) Disconnect all connectors of the PCB, and remove the 2 flat cables [1] and the 10 screws [2]; then, detach the DC controller PCB [3].

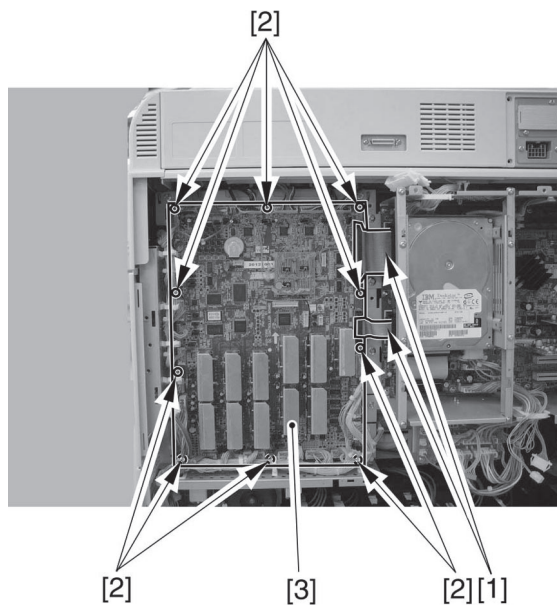

F07-521-04

5.21.1 When Replacing the DC Controller PCB

- 1) After replacing the DC controller PCB, use the following service mode to initialize the memory of the DC controller PCB:
COPIER>FUNCTION>CLEAR>DC-CON
- 2) Enter the settings indicated on the service label using the following service mode:
COPIER>ADJUST>LASER>PVE-OFST
COPIER>ADJUST>FEED-ADJ>REGIST
COPIER>ADJUST>FEED-ADJ>ADJ-REFE
COPIER>ADJUST>CST-ADJ>MF-A4R
COPIER>ADJUST>CST-ADJ>MF-A6R
COPIER>ADJUST>CST-ADJ>MF-A4
- 3) Turn off and then on the main power switch.
- 4) Make the following selections in service mode: COPIER>FUNCTION>LASER>L-ADJ-0.
- 5) Press the OK key. (The machine starts auto adjustment and will indicate 'END' at its end.)

5.22 Removing the Delivery Cooling Fan

- 1) Remove the secondary transfer high-voltage unit. (See 5.3.2 ‘Removing the Secondary Transfer High-Voltage Unit.’)
- 2) Disconnect the connector [1], and remove the 2 screws [2]; then, detach the fan [3].

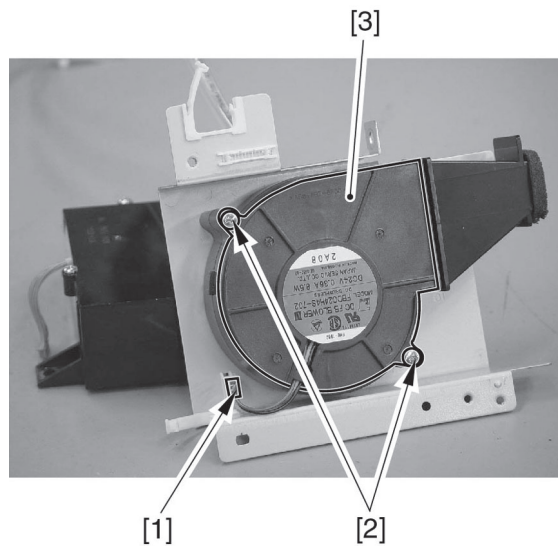

F07-522-01

5.23 Removing the Cleaner Fan

- 1) Open the front cover.
- 2) Remove the screw [1], and detach the cleaner fan cover [2].

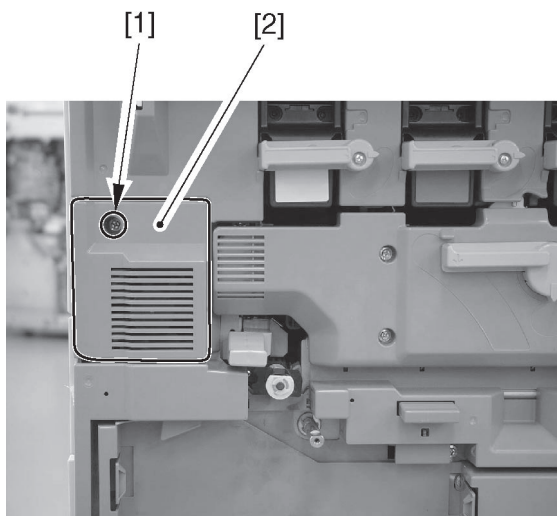

F07-523-01

- 3) Disconnect the connector [1], and free the 3 claws; then, detach the cleaner fan [2].

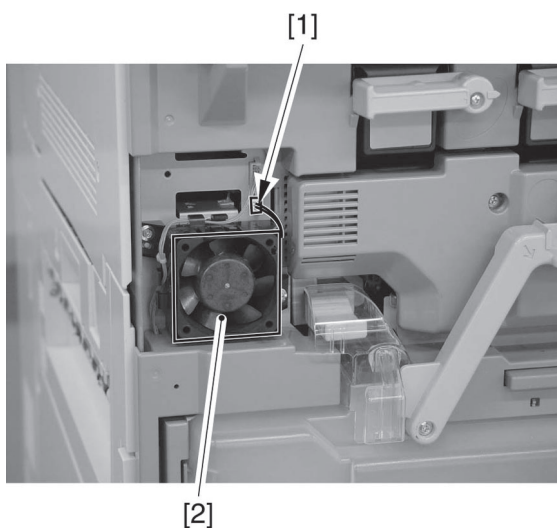

F07-523-02

5.24 Removing the Power Supply Cooling Fan

- 1) Remove the DC power supply unit. (5.6 'Removing the DC Power Supply Unit.')
- 2) Remove the 5 screws [1], and remove the fan base [2]; then, detach the connector [3].

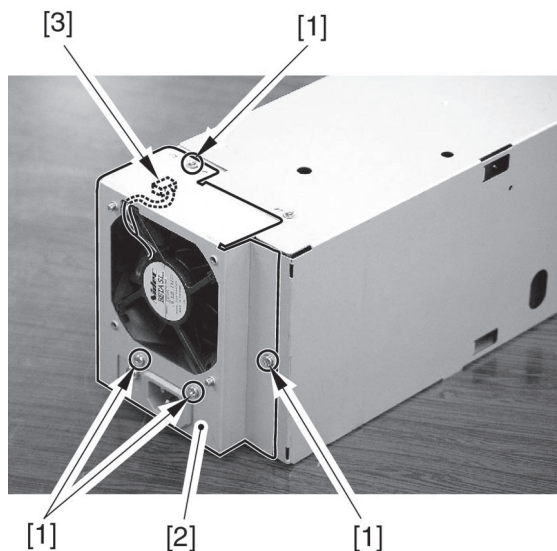

F07-524-01

- 3) Remove the 2 screws [1], and detach the power supply cooling fan [2].

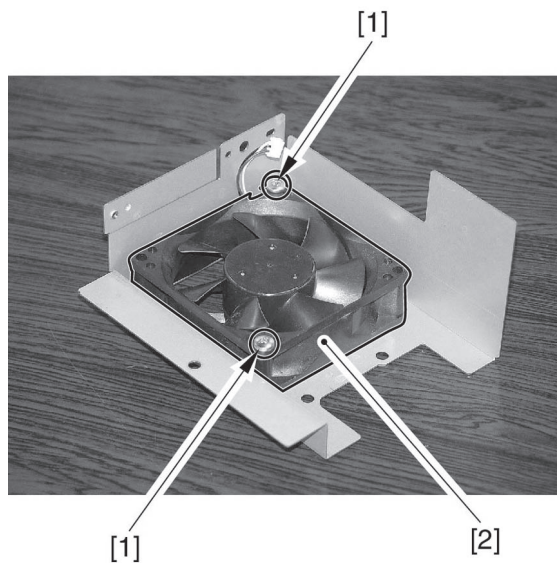

F07-524-02

5.25 Removing the Leakage Breaker

- 1) Remove the DC power supply unit. (See 5.6 'Removing the DC Power Supply Unit.')
- 2) Remove the power supply fan base.
- 3) Remove the 5 screws [1], and disconnect the connectors from the fuse PCB; then, detach the power supply PCB base [2].

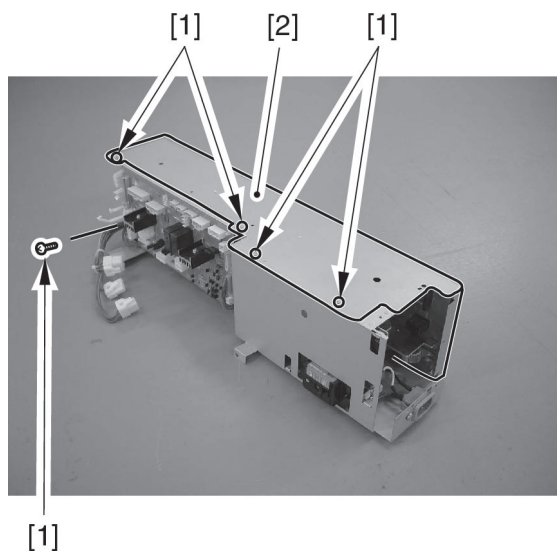

F07-525-01

- 4) Remove the 2 screws [1], and detach the protective plate [1].

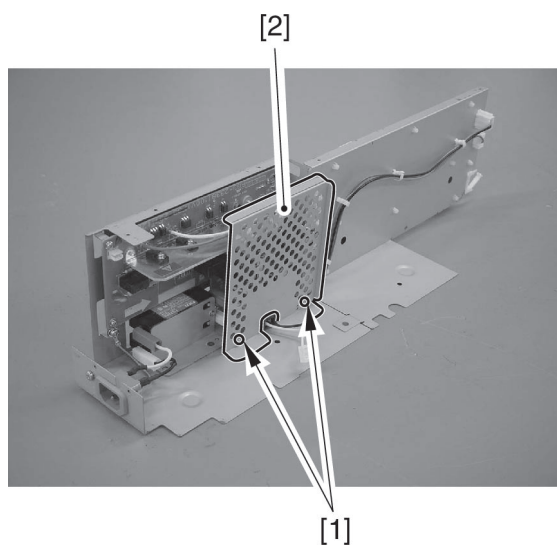

F07-525-02

- 5) Remove the 4 terminals [1] and the 2 screws [2]; then, detach the leakage breaker [3].

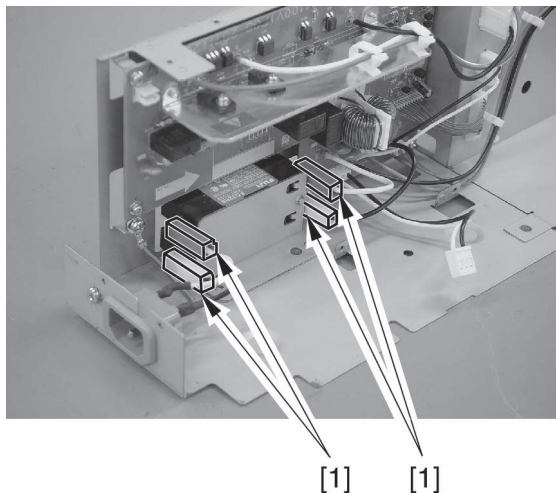

F07-525-03

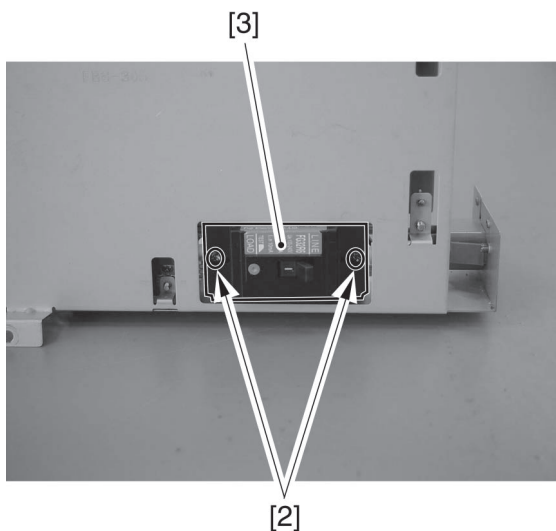

F07-525-04

5.26 Removing the Relay PCB 1

- 1) Remove the upper rear cover, lower rear cover, and left upper rear cover.
- 2) Remove the DC controller PCB cover. (See 5.21 'Removing the DC Controller PCB.')
- 3) Remove the main controller cover. (See 5.21 'Removing the DC Controller PCB.')
- 4) Remove the 2 flat cables [1] used to connect the DC controller PCB and the main controller PCB.

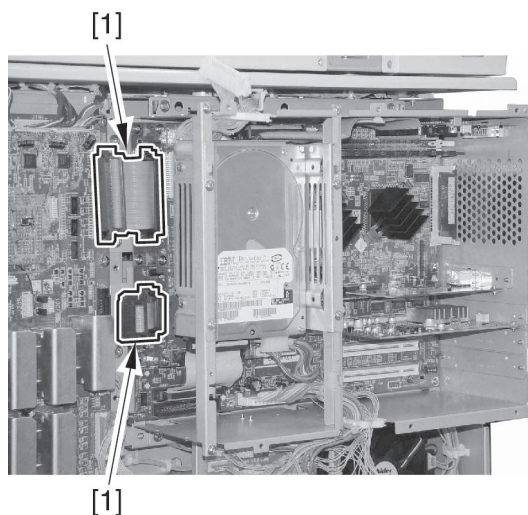

F07-526-01

- 5) Remove the 9 screws [1] of the main controller box.

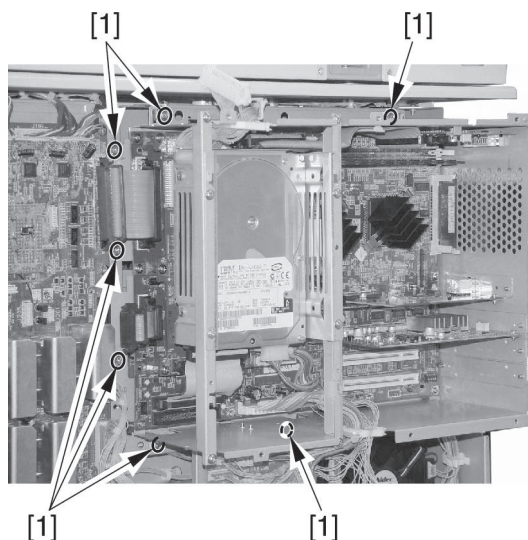

F07-526-02

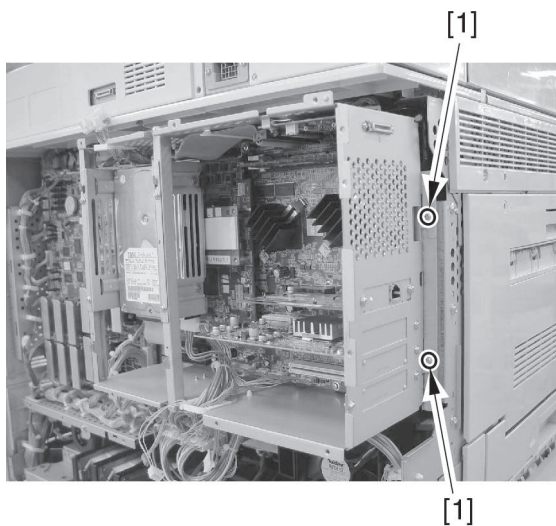

F07-526-03

- 6) Free the controller box from the hook [A/B] at the top of the main controller box.

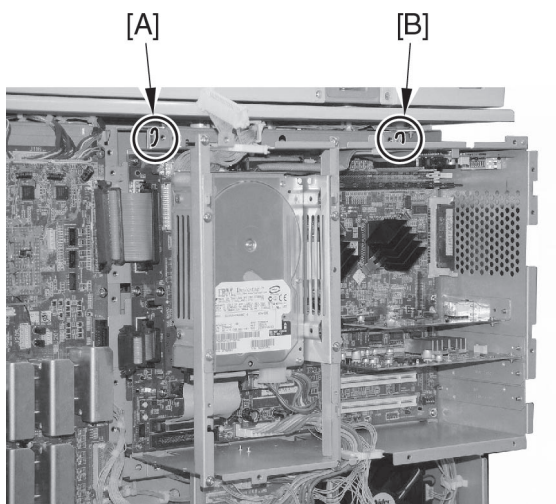

F07-526-04

- 7) Engage the hook [1] found on the right side of the main controller box on the stay [2] of the machine, and open it.

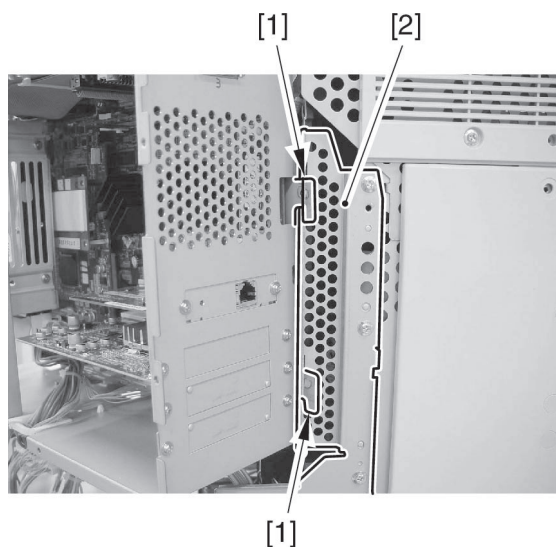

F07-526-05

- 8) Disconnect all connectors from the PCB, and free all harnesses from the cable clamps; then, remove the 7 screws [1], and detach the DC controller PCB [2] together with its base.

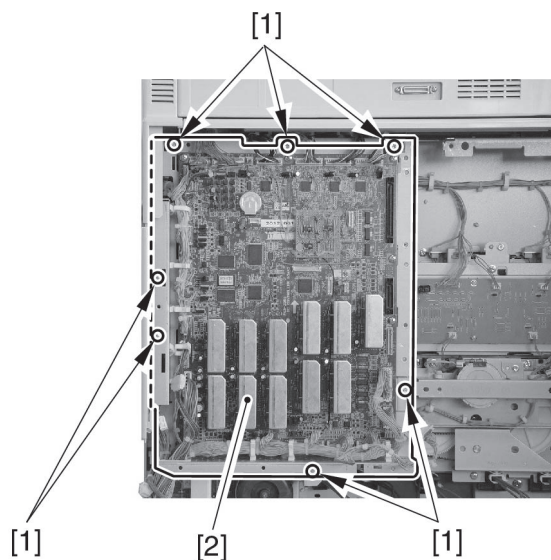

F07-526-06

- 9) Disconnect the 9 connectors [1] and the 8 screws [2] from the PCB; then, detach the relay PCB 1 [3].

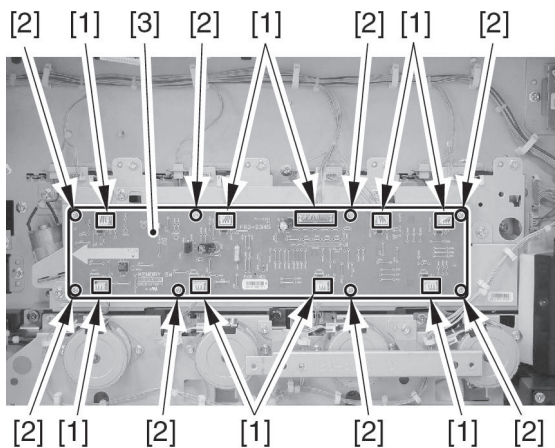

F07-526-07

5.27 Removing the Duplex Driver PCB

- 1) Remove the upper rear cover and the lower rear cover.
- 2) Remove the 2 screws [1], and disconnect all connectors; then, detach the lattice connector base [2].

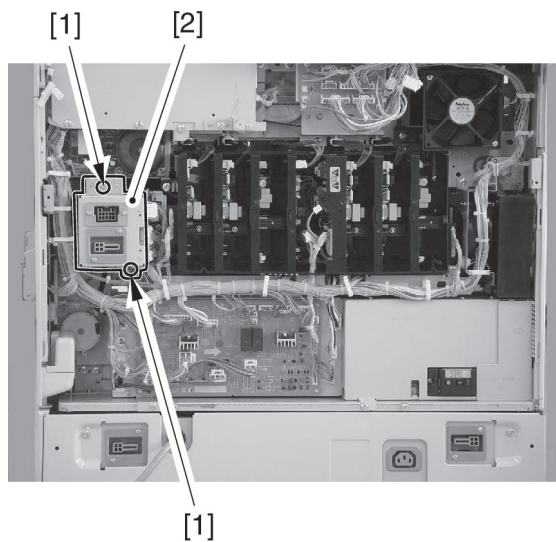

F07-527-01

- 3) Remove the 4 screws [1], and detach the duplex driver PCB [2].

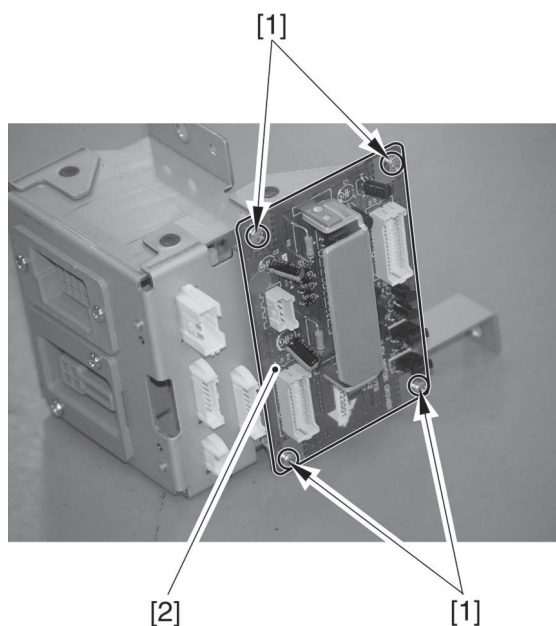

F07-527-02

5.28 Removing the Counter Memory PCB

- 1) Remove the main controller box. (See 5.26 'Removing the Relay PCB 1.')
- 2) Disconnect the connector [1], and remove the 2 screws [2]; then, detach the counter memory PCB [3].

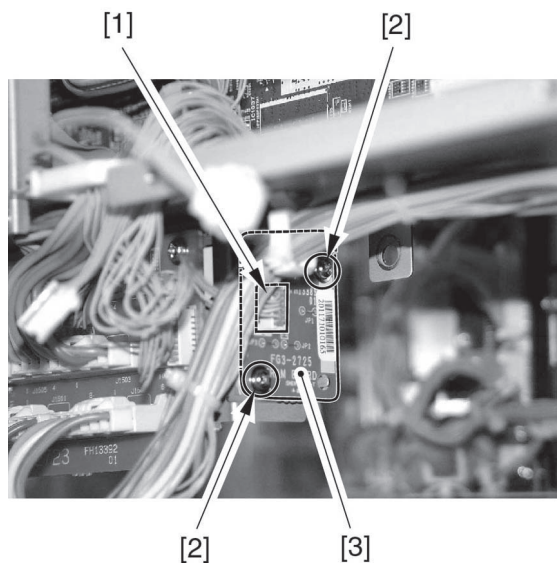

F07-528-01

5.29 Removing the Fuse PCB

- 1) Remove the DC power supply unit. (See 5.6 'Removing the DC Power Supply Unit.')
- 2) Disconnect the 2 connectors [1], and free the 5 card spacers [2]; then, detach the fuse PCB [3].

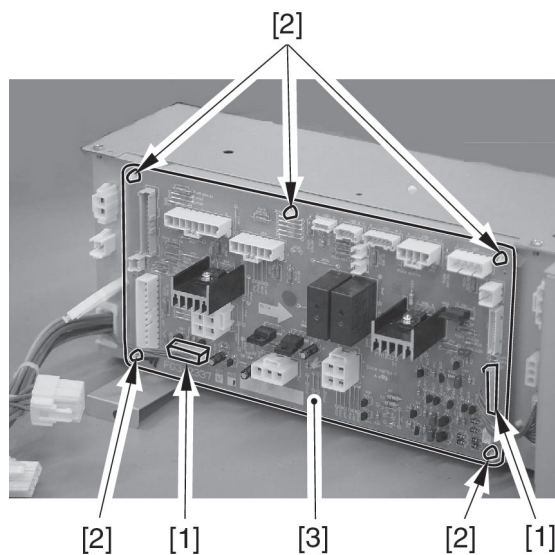

F07-529-01

5.30 Removing the Drum Unit Drive Belt

1) Remove the drum drive unit. (See 6.20 ‘Removing the Drum Drive Unit’ in Chapter 4.)

2)



Never remove the screws [1] (identified by a red marking) used to secure the belt tension plate in place. (The plate is used to maintain a specific degree of tension on the belt.)

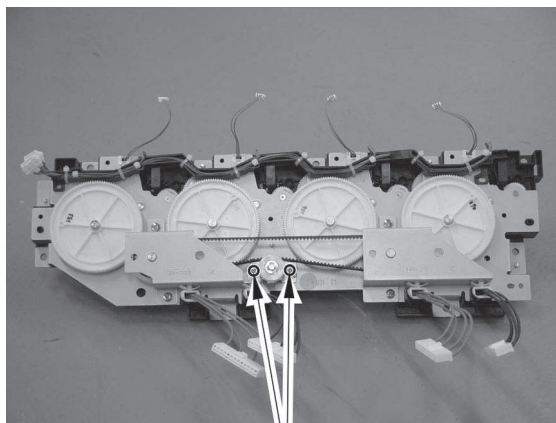

[1]

F07-530-01

Remove the 2 screws [1], and detach the belt tension pulley cover [2]. (2 locations left/right)

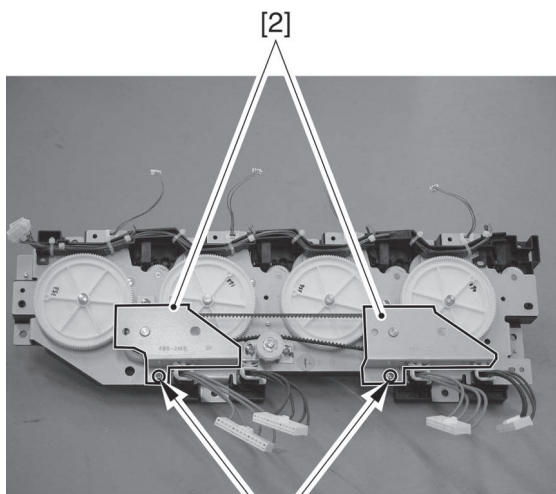

[1]

F07-530-02

- 3) Remove the belt retaining roll [1] found on the right side, and detach the drum unit drive belt [2].

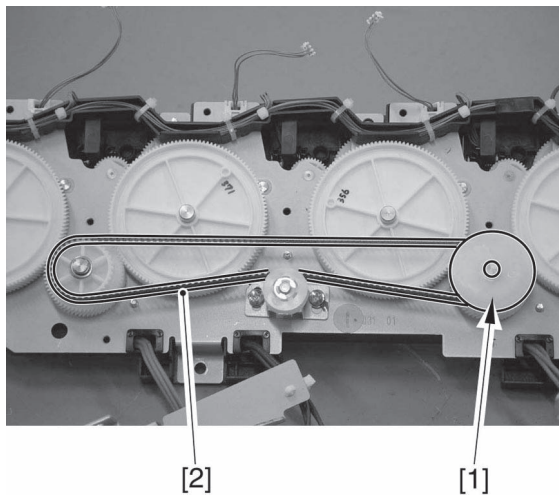

F07-530-03

5.31 Removing the Environment Sensor

- 1) Slide out the manual feed unit.
- 2) Remove the middle right cover.
- 3) Remove the upper right cover.
- 4) Insert a screwdriver through the hole in the upper right stay of the machine, and remove the screw [1]; then, detach the environment sensor mounting plate [2].

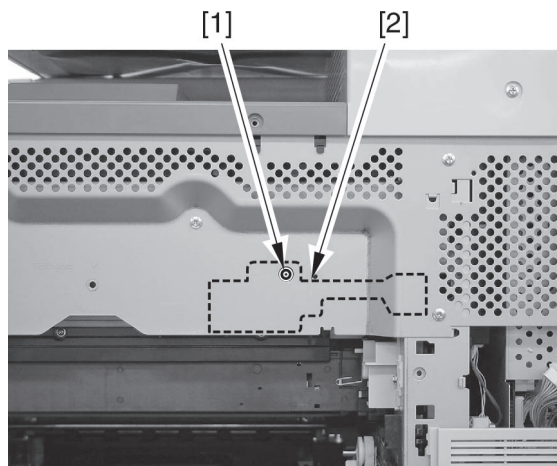

F07-531-01

- 5) Disconnect the connector [1], and free the claw [2] of the sensor base; then, detach the environment sensor [3].

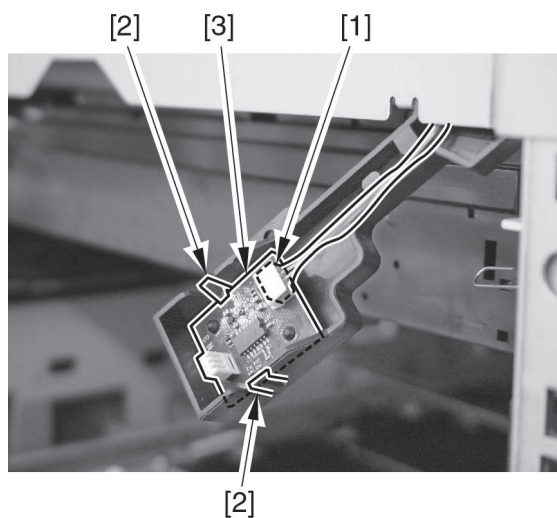

F07-531-02

Accessories

SERVICE MANUAL

Contents

CHAPTER 1 SIDE PAPER DECK-P1

1	Side Paper Deck-P1	1-1	5.1.2	Removing the Front Cover	1-19
1.1	Pickup	1-1	5.1.3	Moving Down the Deck Lifter	1-21
1.1.1	Outline	1-1	5.1.4	Removing the Rear Cover	1-21
1.1.2	Pickup Operation	1-1	5.1.5	Removing the Right Cover	1-22
1.1.3	Sequence of Operations (pickup from deck)	1-3	5.1.6	Removing the Front Cover (upper)	1-23
1.2	Detecting Paper in the Deck	1-4	5.1.7	Removing the Upper Cover	1-23
1.2.1	Detecting the Presence/ Absence of Paper	1-4	5.2	Paper Deck	1-24
1.2.2	Switching the Deck Paper Size	1-5	5.2.1	Removing the Deck from Its Host Machine	1-24
1.2.3	Checking the Level of Paper Inside the Deck	1-5	5.2.2	Removing the Compart- ment	1-26
1.3	Deck Lifter	1-6	5.2.3	Changing the Deck Paper Size	1-28
1.3.1	Detecting the Presence/ Absence of Paper	1-6	5.2.4	After Changing the Deck Paper Size	1-28
1.3.2	Paper Level Indication on the Deck Front Cover	1-8	5.2.5	Checking the Image Rear/ Front Position for Pickup from the Side Paper Deck	1-29
1.4	Opening and Closing the Compartment Door	1-9	5.2.6	Adjusting the Rear/Front Registration for the Side Paper Deck	1-29
1.4.1	Opening and Closing the Compartment Door	1-9	5.2.7	Adjusting the Position of the Spacer	1-30
1.4.2	Sequence of Operations (opening/closing the compartment)	1-10	5.2.8	Adjusting the Height of the Side Spacer	1-30
1.5	Controlling the Deck Motor	1-11	5.3	Drive Mechanisms	1-32
1.5.1	Controlling the Deck Main Motor (M1D)	1-11	5.3.1	Removing the Deck Pickup Clutch (CL2D)	1-32
1.5.2	Controlling the Deck Lifter Motor (M2D)	1-12	5.3.2	Removing the Deck Feeding Clutch (CL1D)	1-32
2	Detecting Jams	1-14	5.3.3	Removing the Deck Main Motor (M1D)	1-33
2.1	Outline	1-14			
3	Error Code	1-16			
4	Alarm Code	1-16			
5	Disassembly/Assembly	1-17			
5.1	External Covers	1-18			
5.1.1	Sliding Out the Compartment	1-18			

5.3.4	Removing the Deck Lifter Motor (M2D)	1-33	5.4.5	Orientation of the Deck Pickup/Feeding Roller	1-42
5.3.5	Removing the Lifter Cable (front of deck)	1-34	5.4.6	Removing the Deck Separation Roller	1-42
5.3.6	Removing the Lifter Cable (rear of deck)	1-36	5.4.7	Adjusting the Deck Separation Roller Pressure	1-43
5.3.7	Routing the Lifter Cable	1-38	5.4.8	Position of the Deck Pickup Roller Releasing Solenoid (SL1D)	1-44
5.4	Feeding System	1-39	5.5	Electrical Mechanisms	1-45
5.4.1	Removing the Deck Pickup Unit	1-39	5.5.1	Removing the Deck Driver PCB	1-45
5.4.2	Removing the Deck Pickup Roller	1-40	5.5.2	Removing the Open Switch PCB	1-45
5.4.3	Orientation of the Deck Pickup Roller	1-40			
5.4.4	Removing the Deck Pickup/Feeding Roller	1-41			

CHAPTER 2 2-CASSETTE PEDESTAL

1	Cassette Pedestal-X1	2-1	3.6	Identifying the Size of Paper	2-6
1.1	Outline	2-1	4	Disassembly/Assembly	2-7
1.2	Construction	2-2	4.1	External Covers	2-7
1.3	Arrangement of Sensors	2-3	4.2	Removing the Pedestal Right Cover Open/Closed Sensor	2-8
1.4	Options Power Supply	2-4	4.3	Removing the Cassette Size Detection Unit	2-10
2	Detecting Jams	2-5	4.4	Removing the Power Supply PCB	2-11
2.1	Delay Jams	2-5	4.5	Removing the Pedestal Controller PCB	2-12
2.2	Stationary Jams	2-5	4.6	Removing the Circuit Breaker	2-13
3	Pickup Unit/Cassette	2-6	4.7	Removing the Pickup Motor	2-14
3.1	Pickup Control System	2-6	4.8	Removing the Pickup Unit	2-16
3.2	Outline	2-6			
3.3	Sequence of Pickup Operations	2-6			
3.4	Identifying the Size of Paper	2-6			
3.5	Identifying the Level of Paper ...	2-6			

CHAPTER 3 PLAIN PEDESTAL

1	Plain Pedestal-C1	3-1	2.2	Removing the Power Supply PCB	3-3
1.1	Outline	3-1	2.3	Removing the Pedestal Controller PCB	3-4
1.2	Construction	3-1	2.4	Removing the Circuit Breaker ...	3-5
1.3	Options Power Supply	3-1			
2	Disassembly/Assembly	3-2			
2.1	External Cover	3-2			

CHAPTER 4 CASSETTE HEATER

1 Cassette Heater Unit-24	4-1	1.3 Setting the Cassette Heater	
1.1 Construction	4-1	Switch to ON	4-3
1.2 Control	4-2		

CHAPTER 5 FAX KIT

1 Overview	5-1	11.2 NUMERIC Param. (Numeric	
2 Specifications	5-3	parameter settings)	5-39
3 G3 FAX control PCB	5-6	12 Initializing settings (#8 CLEAR) ...	5-40
3.1 G3 FAX control PCB element		12.1 SSSW Default Setting	5-41
block diagram	5-6	13 Test mode (#9 TEST)	5-59
3.2 G3 FAX control PCB		13.1 MODEM test	5-61
components	5-6	13.1.1 Relay test (RELAY-1)	5-61
4 NCU PCB	5-8	13.1.2 Frequency test (FREQ)	5-62
4.1 NCU PCB block diagram	5-8	13.1.3 G3 Fax signal output test	
4.2 NCU PCB functions	5-8	(G3TX)	5-63
5 Service Mode	5-9	13.1.4 DTMF output test	5-64
5.1 Overview	5-9	13.1.5 V.34 G3 signal output test	
5.2 Service mode operation	5-10	(V34G3Tx)	5-65
5.3 Meaning of keys	5-11	13.2 Function tests	5-66
6 Service Mode Menu List	5-12	13.2.1 4800bps signal output	
7 Registration of bit switches		test	5-66
(#1 SSSW)	5-15	13.2.2 OGM test	5-67
8 Menu switch settings (#2 MENU) ...	5-29	14 Service reports	5-68
9 Numeric parameter settings		14.1 System data lists	5-68
(#3 NUMERIC Param.)	5-32	14.2 System dump list	5-69
10 Type settings (#5 TYPE)	5-36	14.3 TX error report	5-72
11 Printer function settings		15 Service error codes output	5-73
(#7 PRINTER)	5-37	16 Error codes	5-74
11.1 Service soft switch settings	5-37	17 Error code list	5-76

CHAPTER 6 UFR PRINTER AND SCANNER KIT-A1

1 Product Outline	6-1	2.2.4 Super smooth	6-5
2 Specifications and Functions	6-2	2.2.5 Gradation settings	6-5
2.1 Specifications	6-2	3 Cautions when performing field	
2.2 New functions	6-5	service/ Reference items	6-6
2.2.1 Image data flow	6-5	3.1 Cautions when installing	6-6
2.2.2 Printing purpose	6-5	3.2 Other cautions	6-6
2.2.3 Toner saving	6-5		

CHAPTER 7 RESOLUTION SWITCHING BOARD-A1

1 Product Outline	7-1	3.1 Cautions when installing	7-3
2 Specifications and Functions	7-2	3.2 Other cautions	7-3
3 Cautions when performing field service/Reference items	7-3		

CHAPTER 8 COLOR UNIVERSAL SEND KIT-A1P/A1U

1 Product configuration	8-1	2.2.3 I-FAX transmission data flow	8-5
2 Specifications and functions	8-2	3 Cautions when performing field service/Reference items	8-7
2.1 Specifications	8-2	3.1 Cautions when installing	8-7
2.2 Functions	8-3	3.2 Other cautions	8-7
2.2.1 Monochrome transmission (E-mail, file transfer) data flow	8-3		
2.2.2 Colour transmission (E-mail, file transfer) data flow	8-4		

CHAPTER 9 USB INTERFACE BOARD-A1

1 Product configuration	9-1	3.1 Cautions when installing	9-3
2 Specifications and functions	9-2	3.2 Other cautions	9-3
2.1 Specifications	9-2		
3 Cautions when performing field service/Reference items	9-3		

CHAPTER 10 COLOR NETWORK MULTI-PDL PRINTER KIT-A1

1 Product Composition	10-1	2.2.1 Flow of Image Data	10-6
2 Specifications and Functions	10-2	2.3 Points to Note About Servicing in the Field (supplementary information)	10-9
2.1 Specifications	10-2		
2.2 New Functions	10-6		

CHAPTER 11 iR SECURITY KIT-A1P/A1U

1 Product Composition	11-1	3 Points to Note About Servicing in the Field (reference).....	11-4
2 Specifications and Functions	11-2	3.1 Installation	11-4
2.1 Outline	11-2	3.2 Other Points to Note	11-4
2.2 Specifications	11-2		
2.3 Security Functions	11-2		

CHAPTER 1

SIDE PAPER DECK-P1

1 Side Paper Deck-P1

1.1 Pickup

1.1.1 Outline

Paper Deck (hereafter, deck)

Number of sheets: 2500 (A4/LTR/B5; paper of 80 g/m²)

Operation: in response to control signals from the host machine's DC controller)

Drive: deck lifter motor (M20) for movement of the deck
deck main motor (M1D) for pickup/feeding of paper

1.1.2 Pickup Operation

The paper placed inside the deck is held up by the lifter, and is kept in position at a specific height.

When the Start key is pressed, the deck pickup clutch (CL2D) goes ON. Then, the deck main motor (M1D) goes ON, and the rotation of the pickup roller moves the paper into the machine.

The pickup/feeding roller and the separation roller make sure that no more than a single sheet of paper is picked up.

After the deck pickup sensor (PS1D) has detected the presence of paper, the pickup roller leaves the surface of paper when the deck pickup roller releasing solenoid (SL1D) goes ON.

When the paper is moved farther, the deck feeding clutch (CL1D) goes ON to rotate the deck feeding roller, thereby moving the paper as far as the registration roller of the host machine and causing it to arch for correction of any skew.

The registration roller is controlled so that the image on the photosensitive drum and the leading edge of the paper will match.

If no paper is detected within a specific period of time,

If, for some reason, the deck pickup sensor (PS6D) does not detect paper in response to the deck pickup detection signal, the machine will indicate an alarm code.



COPIER>DISPLAY>ALARM2
Option deck retry alarm: 040018

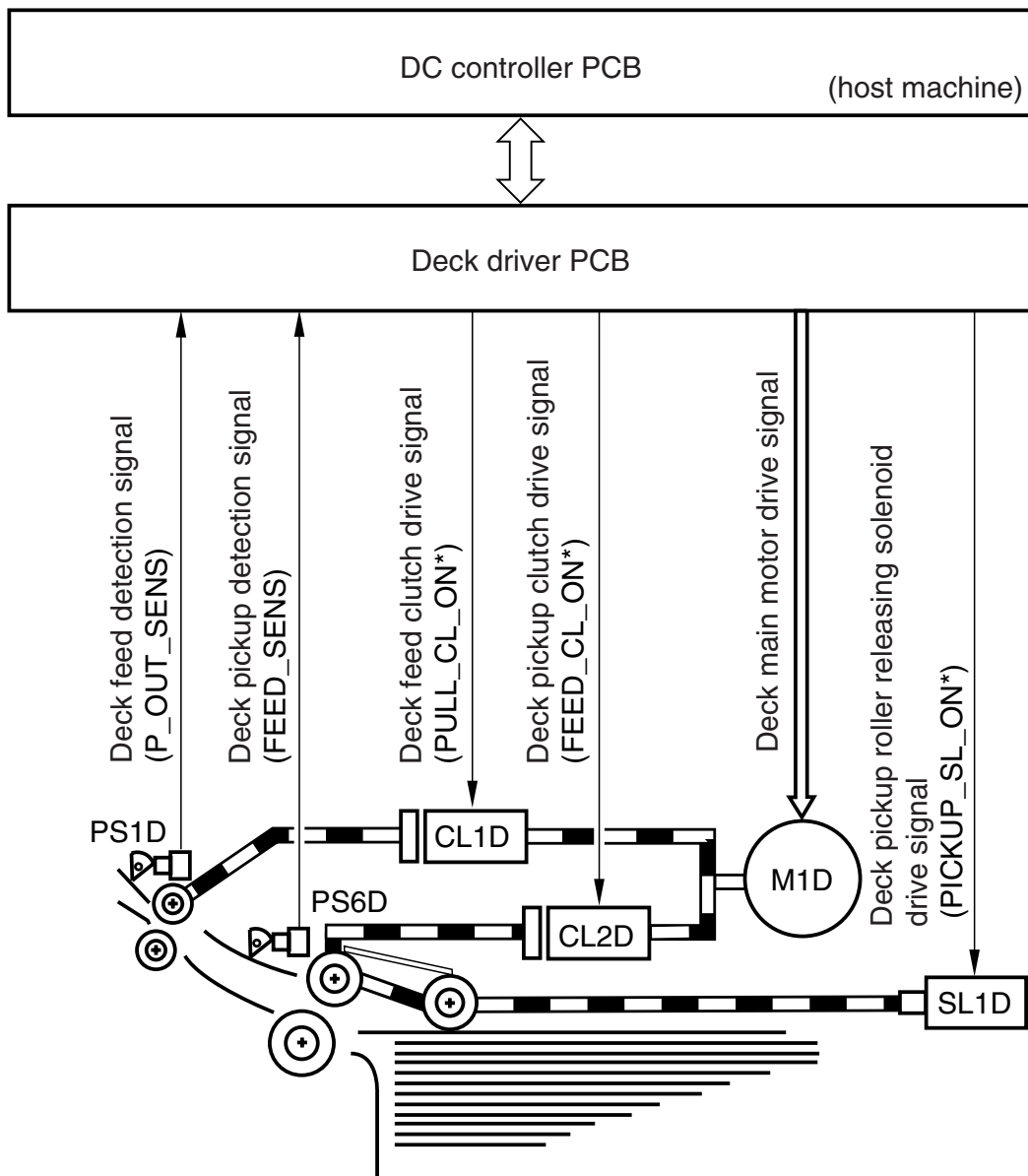

F01-101-01

1.1.3 Sequence of Operations (pickup from deck)

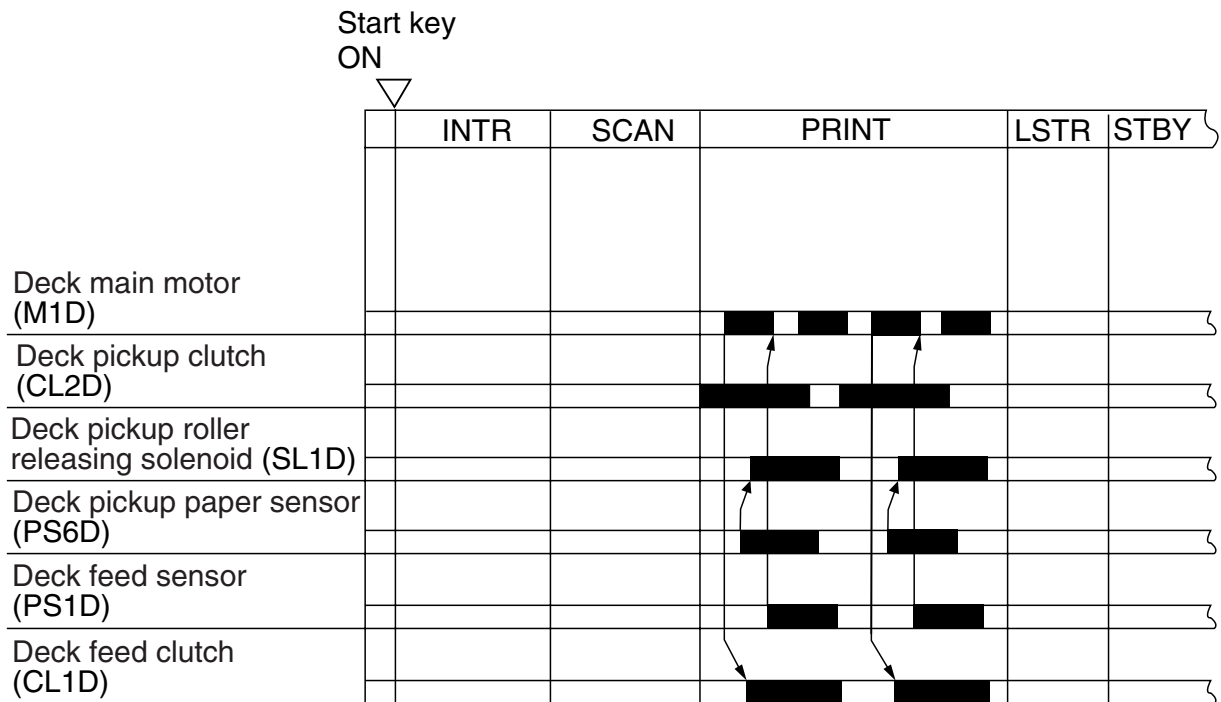

F01-101-02

1.2 Detecting Paper in the Deck

1.2.1 Detecting the Presence/Absence of Paper

The machine uses the deck paper sensor [1] (PS2D) to detect the presence/absence of paper.

- All paper is gone from the lifter [2].
- The paper detecting lever [4] of the pickup roller assembly leaves the deck paper sensor.
- The machine indicates the Add Paper message (on the host machine's control panel).

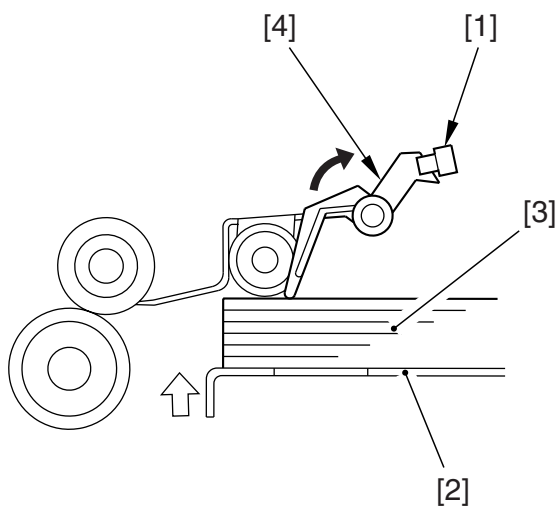

F01-102-01

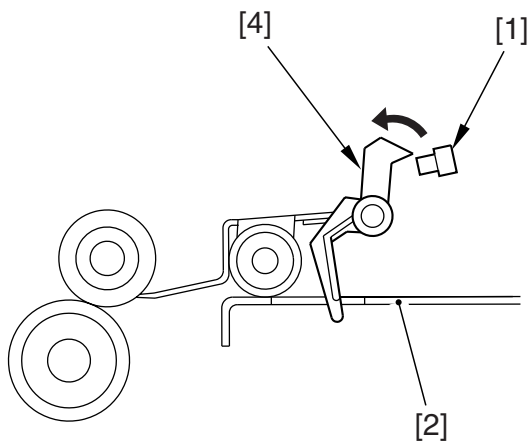

F01-102-02

1.2.2 Switching the Deck Paper Size

- Enter the size of paper in service mode (OPTION>ACC>DK-P).
- Move the guide plate inside the deck to suit the size of the paper, and enter the size in service mode. (at time of installation or at the user's request)

1.2.3 Checking the Level of Paper Inside the Deck





The machine uses the following sensors to detect the level of paper inside the deck:

Deck paper supply position sensor (PS8D)

Deck paper level sensor (PS7D)

Deck paper sensor (PS2D)

The machine is capable of indicating an approximate level of paper remaining inside its compartment using the host machine's control panel:

Paper level	PS2D	PS8D	PS7D	Indication on control panel
100% to about 50%	1	1	1	
About 50% to about 10%	1	1	0	
About 10% or less	1	0	0	
No paper	0	0	0	

1: Light-blocking plate over sensor

0: Light-blocking plate not over sensor

T01-102-01

1.3 Deck Lifter

1.3.1 Detecting the Presence/Absence of Paper

The machine's lifter checks the presence/absence of paper as follows:

Operations: moved up or down by changing the direction of rotation of the deck lifter motor (M2D).

Drive: supplied by the deck lifter motor (M2D); connected to a reel by means of a cable.

1. Moving Up the Lifter

- The compartment is slid inside the deck.
- The deck detecting switch (SW1D) is pressed.
- The deck open sensor (PS9D) detects the light-blocking plate.

■ Stopping the Lifter

The lifter is stopped where the deck lifter position sensor (PS4D) detects the top surface of the stack of paper placed on it.

Preventing Damage to the Deck by an Abnormal Rise

- The deck lifter upper limit sensor (PS3D) is set so that it turns on if, for some reason, the sensor lever blocks the deck lifter position sensor (i.e., the deck fails to stop rising).

2. Moving Down the Lifter

- The deck open switch (SW100D) is pressed.

■ Stopping the Lifter

The lifter is stopped where the lever of the deck paper supply position sensor (PS8D) leaves the lifter (i.e., at the falling edge of the sensor signal).

Paper Supply

- Paper, when supplied, will push the lever of the deck paper supply position sensor (PS8D). The lifter moves farther down until the paper leaves the sensor lever.

3. Paper Supply

Each time paper is supplied, the lifter repeatedly moves down until it reaches the deck lifter lower limit detecting switch (SW2D) (i.e., maximum paper supply position).

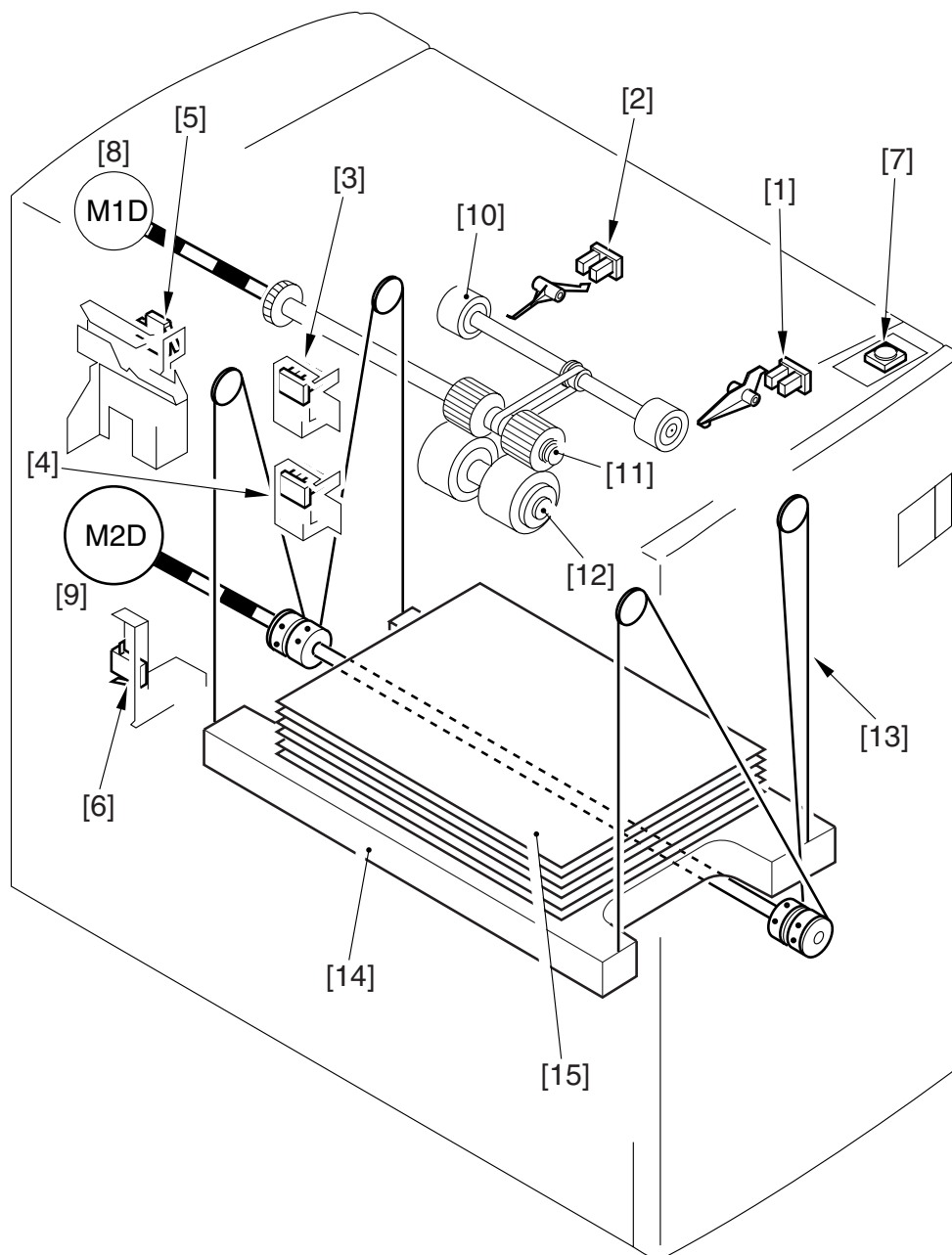

F01-103-01

- | | |
|---|-----------------------------|
| [1] Deck lifter upper limit sensor (PS3D) | [8] Deck main motor (M1D) |
| [2] Deck lifter position sensor (PS4D) | [9] Deck lifter motor (M2D) |
| [3] Deck paper supply position sensor (PS8D) | [10] Pickup roller |
| [4] Deck paper level sensor (PS7D) | [11] Feeding roller |
| [5] Deck open detecting switch (SW1D) | [12] Separation roller |
| [6] Deck lifter lower limit detecting switch (SW2D) | [13] Deck lifter cable |
| [7] Deck open switch (SW100D) | [14] Lifter |
| | [15] Paper |

1.3.2 Paper Level Indication on the Deck Front Cover

- Paper runs out.
- The lifter moves up to the paper supply position.
The area of black of the belt in the window increases gradually (conversely, the area of white indicating the amount of paper decreases gradually).
- The level of paper may be checked in the window.

Path of the Drive

Driving the Deck Lifter Motor [1] (M2D)

- coupling [2]
- drive belt [3]
- rack [4]
- black belt [5]

In keeping with the movement of the rack, the black belt attached to the rack moves up and down in the window [7], found in the deck front cover [6].

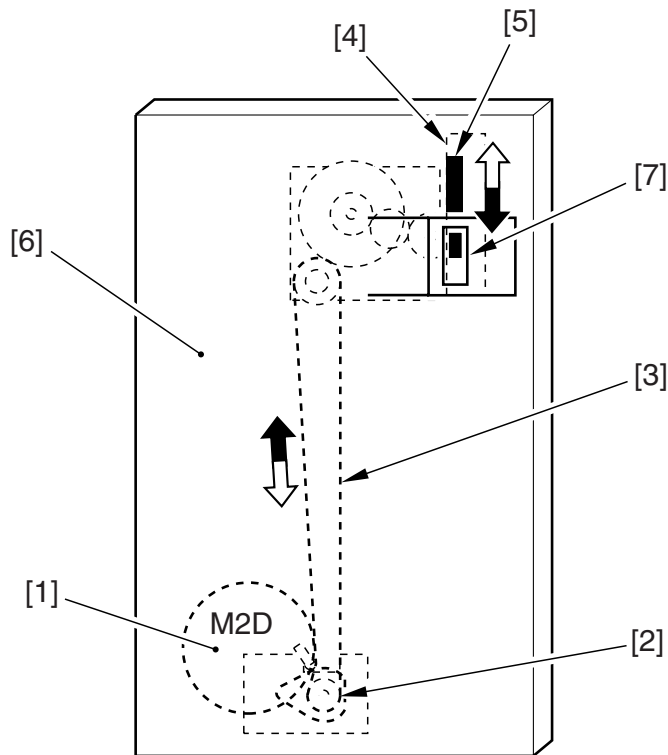

F01-103-02

1.4 Opening and Closing the Compartment Door

1.4.1 Opening and Closing the Compartment Door

When the Door Is Opened

- The deck open switch (SW100D) is pressed.
- The deck solenoid (SL2D) goes ON.
- The lock of the compartment is released, and the force of a spring pushes it several centimeters to the front.
- The deck lifter motor is started.
- The lifter inside the compartment starts to move down.

When the Door Is Closed

- The compartment is slid inside the deck.
- The deck open sensor (PS9D) detects the light-blocking plate of the compartment.
- The lifter moves up to the pickup position.

Deck Open Indicator (LED100D) Remains ON or Flashes

The deck open indicator remains ON or flashes to indicate that the deck lifter motor is rotating.

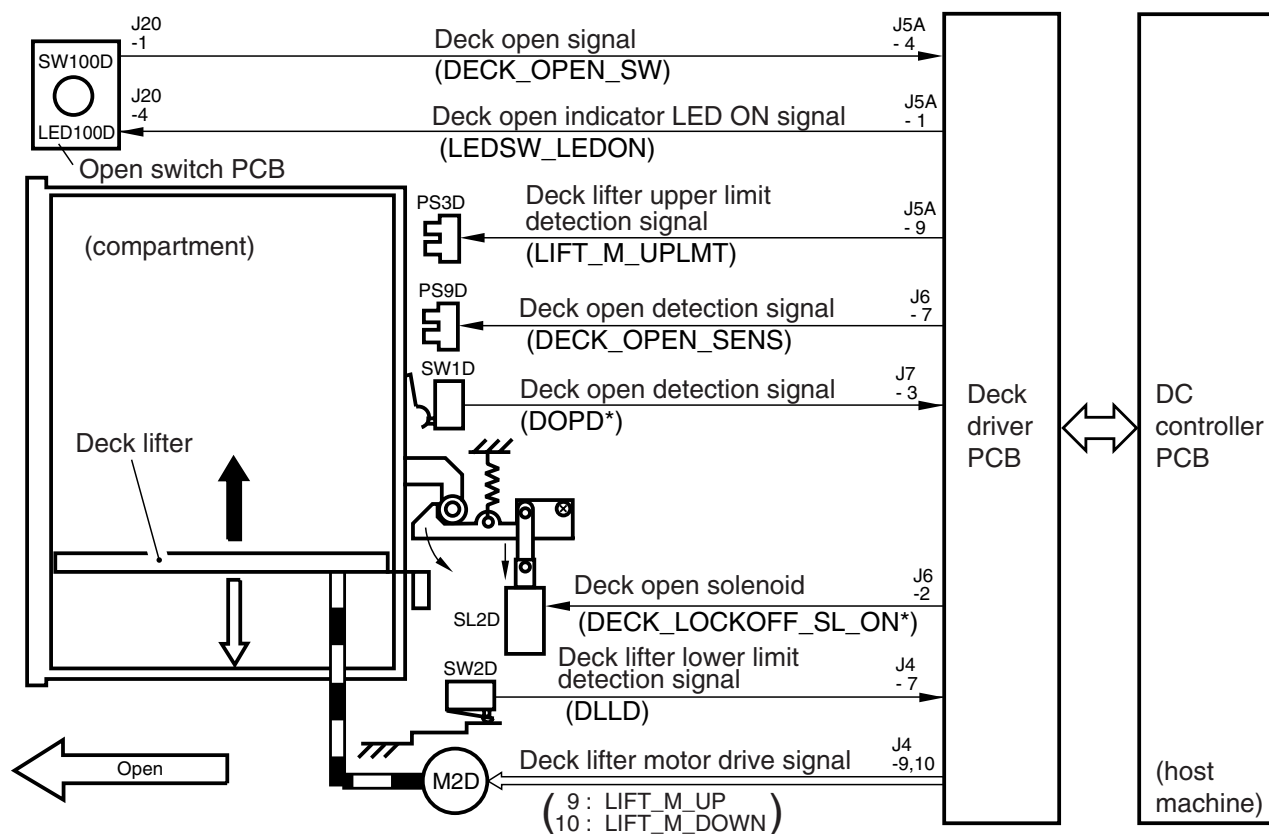

F01-104-01

1.4.2 Sequence of Operations (opening/closing the compartment)

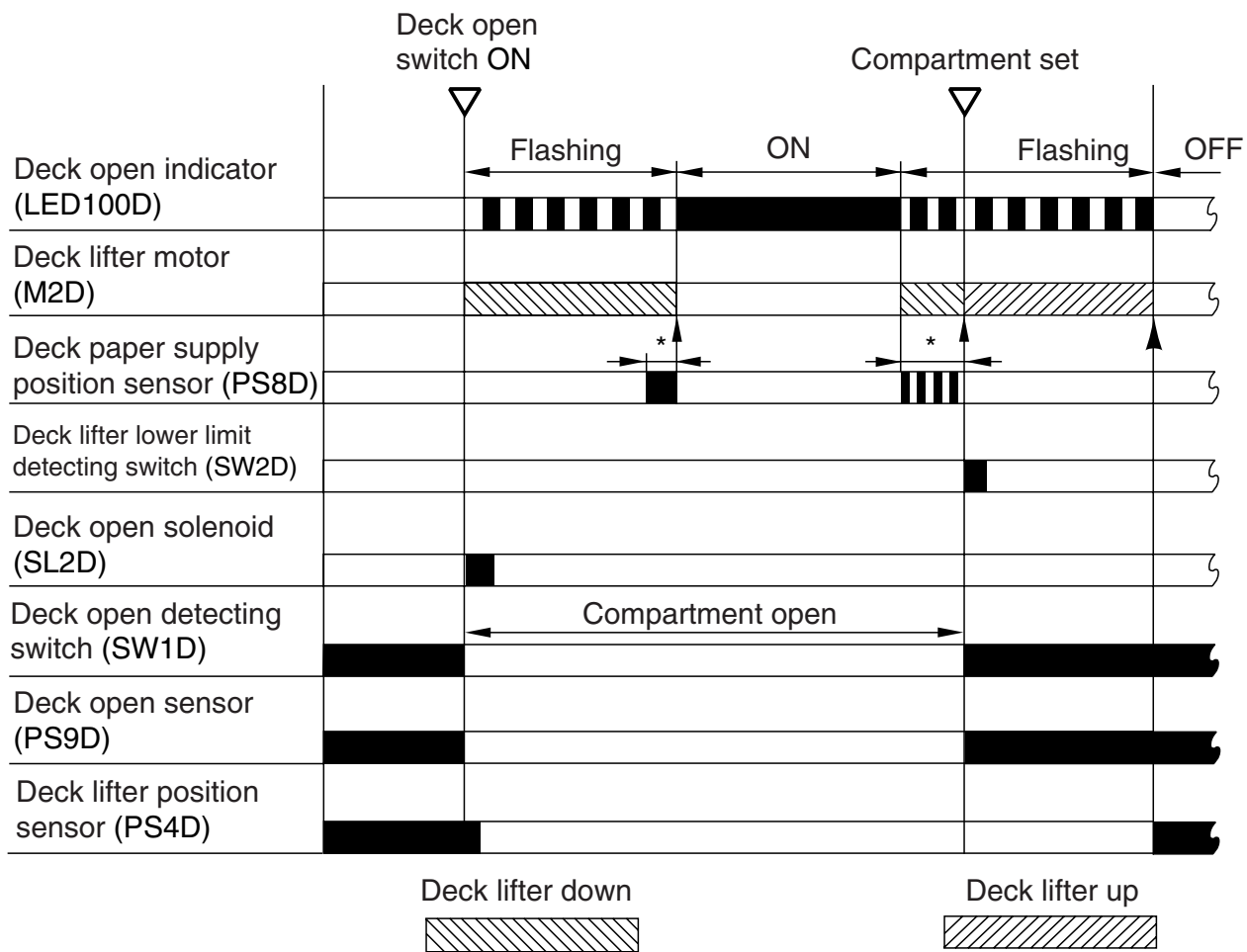

* : varies according to the amount of paper.

F01-104-02

1.5 Controlling the Deck Motor

1.5.1 Controlling the Deck Main Motor (M1D)

Motor: pulse motor

Operation: in keeping with the control signals from the host machine's DC controller

The following is a diagram of the circuit used to drive the deck main motor, which has the following function:

1. turning on/off the deck main motor

a. Turning On/Off the Motor

The deck main motor is turned on/off or the direction and speed of its rotation is changed in keeping with how the following serial signals from the host machine are controlled: FEED_M_A, FEED_M_A*, FEED_M_B, FEED_M_B*.

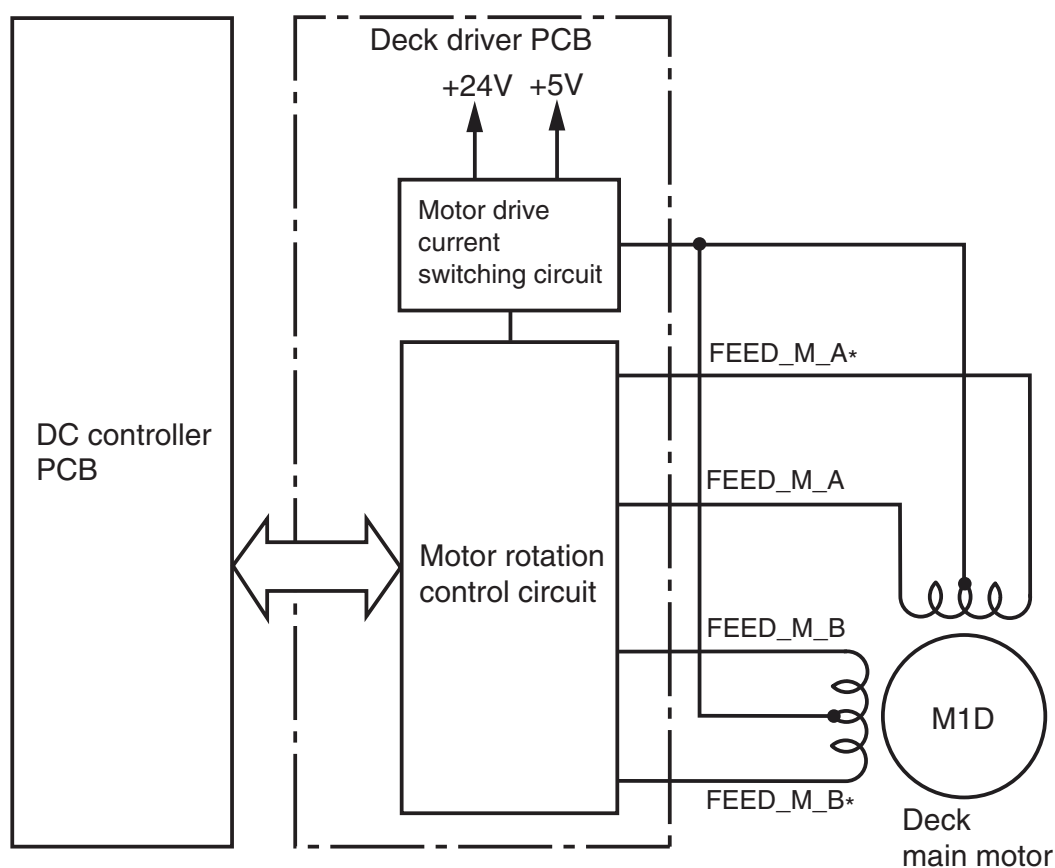

F01-105-01

1.5.2 Controlling the Deck Lifter Motor (M2D)

The deck driver PCB executes various control mechanisms; F08-105-02 is a block diagram of these mechanisms.

The combination circuit found in the diagram consists of various logic circuits, and the following combinations are used to rotate the deck lifter motor clockwise or counterclockwise:

- output signals from the sensors
- deck lifter motor drive commands/deck lifter UP command (from the host machine's DC controller)

If the lifter is not detected within a specific period of time,

If the deck lifter position sensor (PS4D) does not detect the lifter in spite of the deck lifter UP signal, the machine will indicate an alarm code:

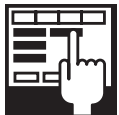

COPIER>DISPLAY>ALARM2
option deck lifter error: 040008

1. Conditions for Moving Up the Lifter (a through e must exist)
 - a. The deck is connected to its host machine.
deck set signal (DECK_MOUNT_SENS) = '1'
 - b. The compartment is closed.
deck open detection signal (DECK_OPEN_SENS) = '1'
deck open detecting switch (DECK_OPEN_SW) = 'ON'
 - c. deck lifter upper limit detection signal (LIFT_M_UPLMT) = '0'
in addition,
deck lifter position detection signal (PAP_TOP_SENS) = '0'
 - d. deck lifter motor down signal (LIFT_M_DOWN) = '0'
 - e. deck lifter up signal (LIFT_M_UP*) = '0'
2. Conditions for Moving Down the Lifter (a through d must exist)
 - a. The compartment is open.
deck open detection signal (DECK_OPEN_SENS) = '0'
 - b. deck lifter down signal (LIFT_LOW_LMT) = '0'
in addition,
deck lifter position detection signal (PAP_TOP_SENS) = '0'
 - c. deck lifter motor down signal (LIFT_M_DOWN) = '1'
 - d. deck lifter up signal (LIFT_M_UP*) = '1'

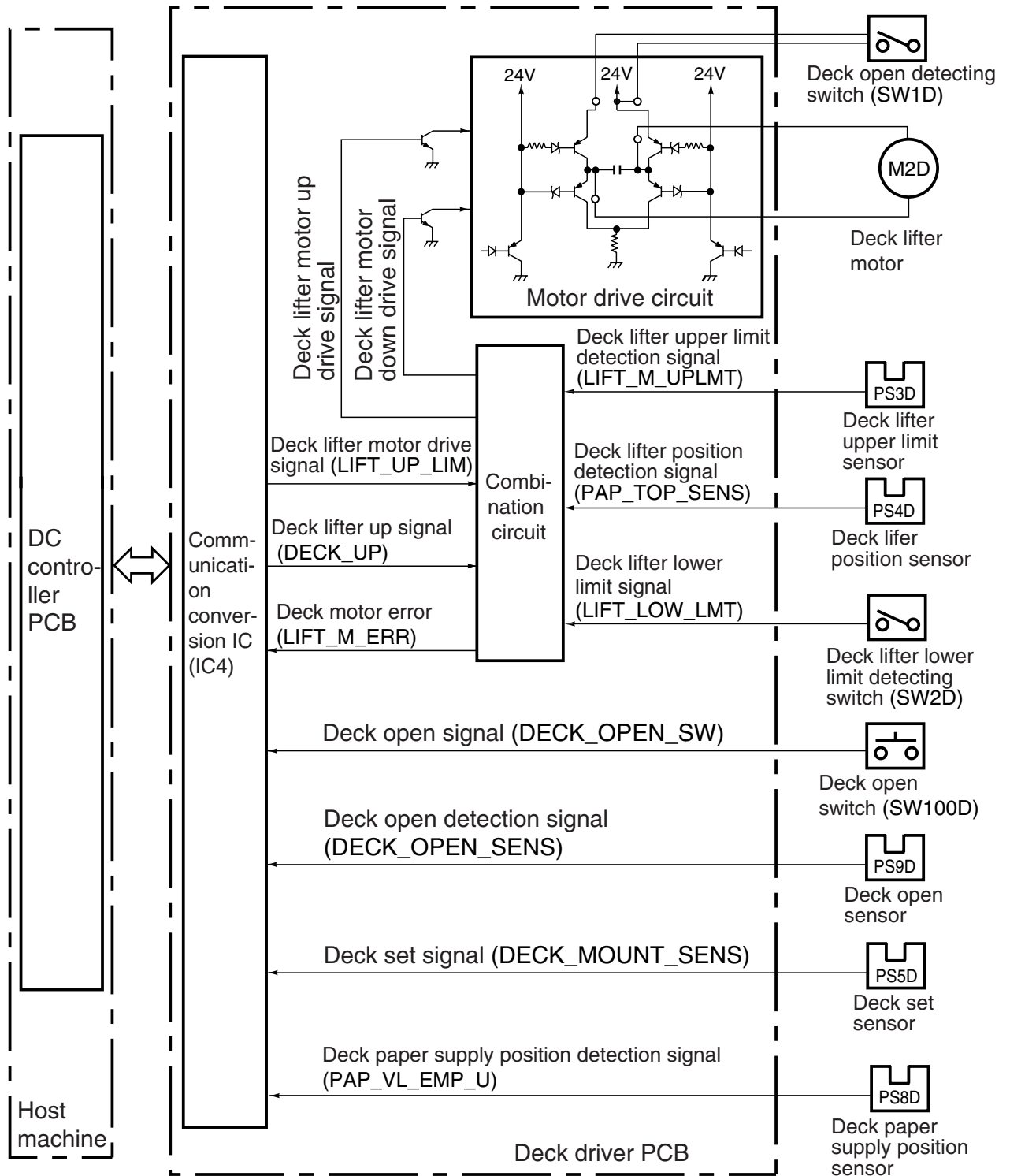

Note: The communication conversion IC (IC4) shown in the diagram is used for conversion between serial and parallel signals.

F01-105-02

2 Detecting Jams

2.1 Outline

The paper deck is equipped with 2 sensors as shown in F08-201-01.

Reading Signals from the Sensors

The signals from the sensor are read at such times as programmed in the host machine's DC controller.

Checking the Movement of Paper

The movement of paper is checked by the host machine's DC controller.

Upon Detection of a Jam

When a jam is detected, the machine will discharge all paper that precedes the jam and then stop its operation. Thereafter, it will indicate instructions for the removal of jams using the host machine's control panel.

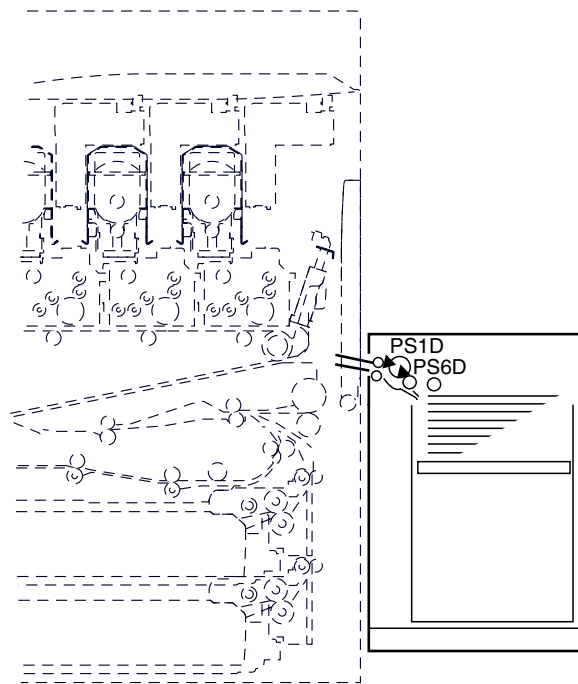

F01-201-01

Sensor No.	Name	Description
PS1D	Deck feed sensor	delay/stationary jam detection
PS6D	Deck pickup sensor	delay/stationary jam detection

T01-201-01

The host machine's DC controller identifies any of the following conditions as jam conditions:

1. There is paper over the deck feed sensor (PS6D) when the host machine's power switch is turned on or image stabilization control is under way.
2. Deck Pickup/Vertical Path Delay Jam

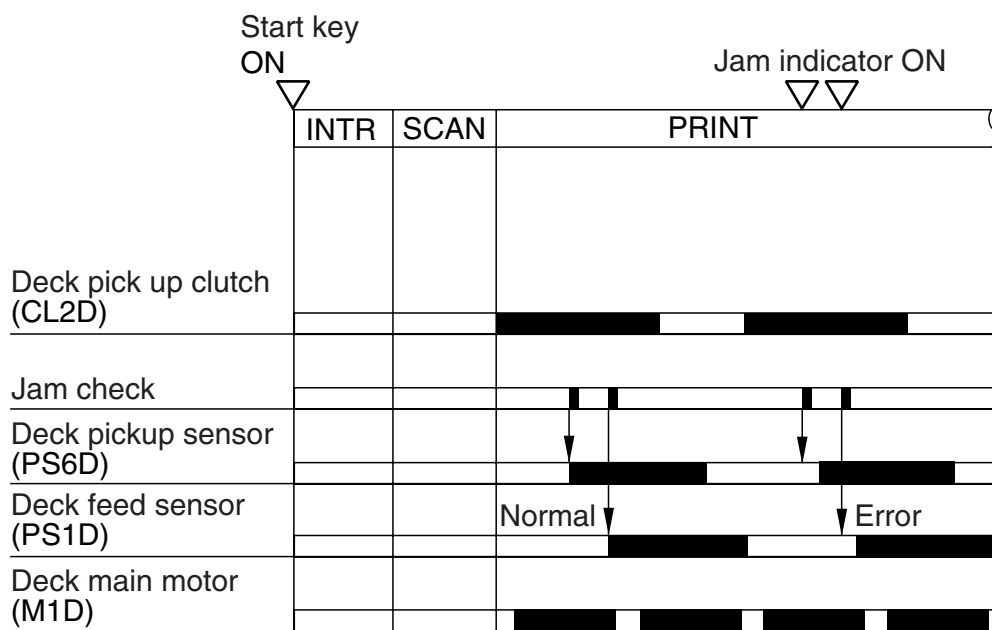

F01-201-02

3. Deck Pickup/Vertical Path Stationary Jam

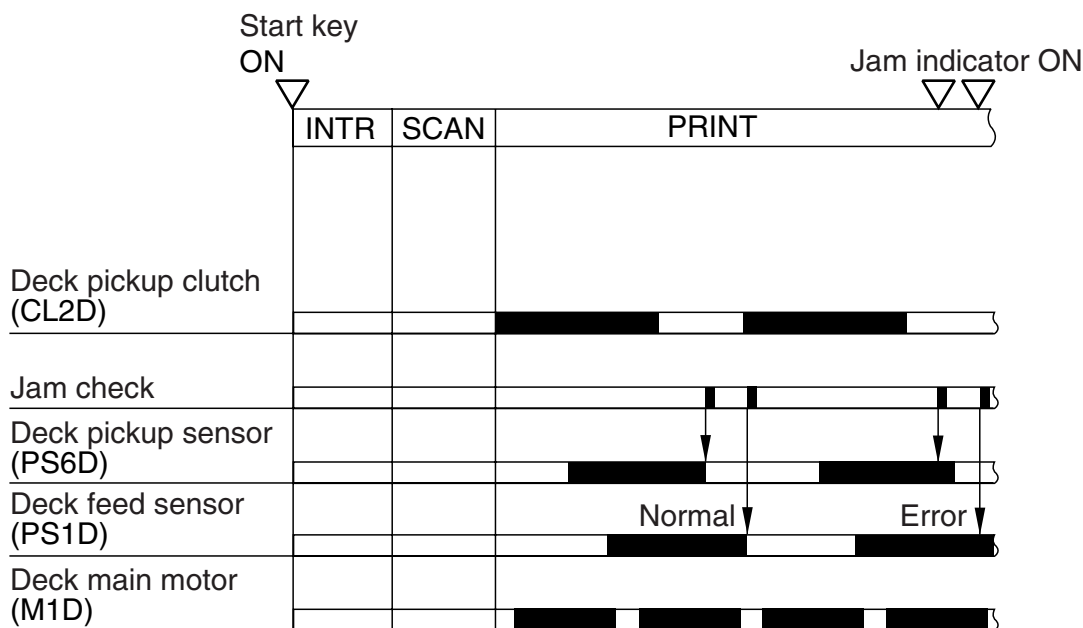

F01-201-03

3 Error Code

There is no error code that is unique to the paper deck. The use of error codes is in keeping with how they are used in its host machine.



4 Alarm Code

An alarm code will be indicated in service mode (COPIER>DISPLAY>ALARM2) if the paper deck detects any of the following:

Sensor No.	Description	Code
PS6D	The pickup signal is not detected.	040018
PS4D	The lifter up signal is not detected.	040008

5 Disassembly/Assembly

The pages that follow explain the machine's mechanical characteristics and how its components may be taken apart or put together; for the work, be sure of the following:

1.  For safety, disconnect the power plug before starting the disassembly/assembly work.
2. Unless otherwise indicated, assemble the parts by reversing the steps indicated for disassembly.
3. Identify the screws by type (length, diameter) and location.
4. Use a screw with washers when fitting the grounding wire, varistor, and the like so as to ensure electrical continuity.
5.  As a rule, do not operate the machine with any of its parts removed.

5.1 External Covers

- [1] Deck releasing grip
- [2] Front cover (upper)
- [3] Compartment open/close switch
- [4] Front cover
- [5] Right cover
- [6] Upper cover
- [7] Rear cover

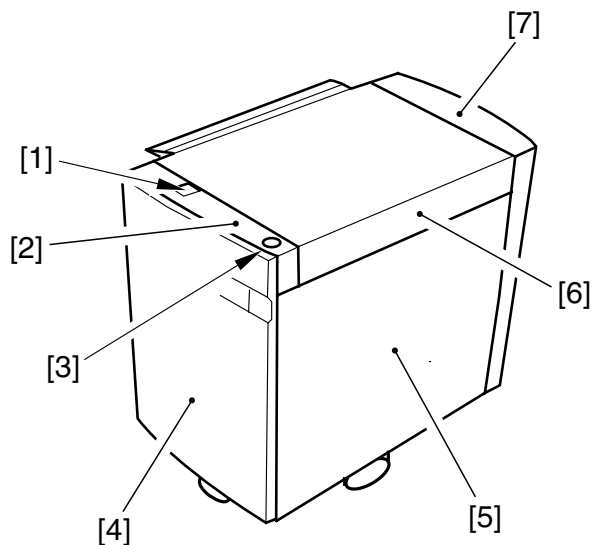

F01-501-01

5.1.1 Sliding Out the Compartment

- 1) Push the deck releasing grip [1] to detach the deck from the host machine; then, push down the latch plate [2] found at the left rear with a finger to open the compartment.

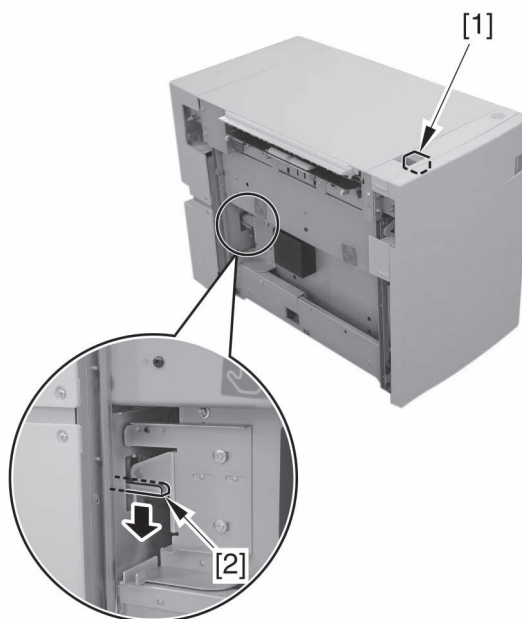

F01-501-02

5.1.2 Removing the Front Cover

- 1) Open the compartment. (See 5.1.1.)
- 2) Loosen the 4 screws [1], and detach the front cover [2] toward the front.

Do not remove these screws.

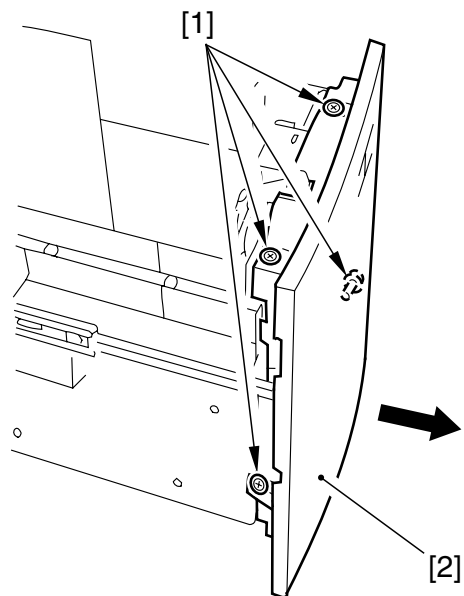

F01-501-03



-
1. When attaching the front cover, be sure that the coupling [1] used to indicate the paper level is correctly matched.
-

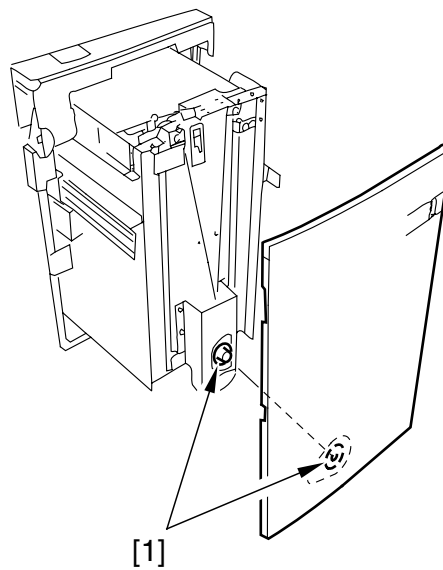

F01-501-04



2. Adjust the position of the front cover by using 4 screws on it so that gap A between the front cover [1] and the front cover top [2] is 3 ± 1 mm.
3. If you moved the paper level indicator belt or the deck lifter, you must adjust the paper level indicator.

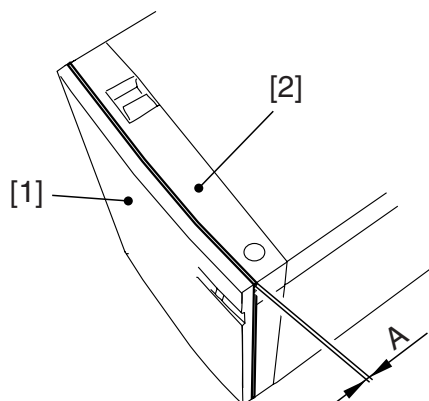

F01-501-05

Adjusting the Paper Level Indicator

- 1) Move the drive belt [2] of the paper level indicator found in the front cover [1] in the direction of the arrow [4] lightly by hand (i.e., so that the area of white increases).



Keep in mind that you can damage the drive mechanism of the paper level indicator if you operate the deck without correcting the spatial relationship between the paper level indicator and the deck lifter.

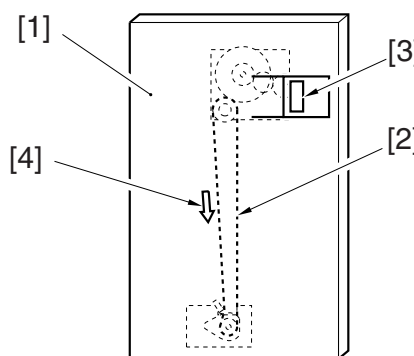

F01-501-06

5.1.3 Moving Down the Deck Lifter

- 1) Open the compartment. (See 5.1.1.)
- 2) Remove paper, if any.
- 3) Connect the power plug, and turn on the host machine.
- 4) Push the sensor flag [2] of the paper supply position sensor found in the compartment [1] with a finger to move down the deck lifter. (The deck lifter will stop where you let go of the flag.)

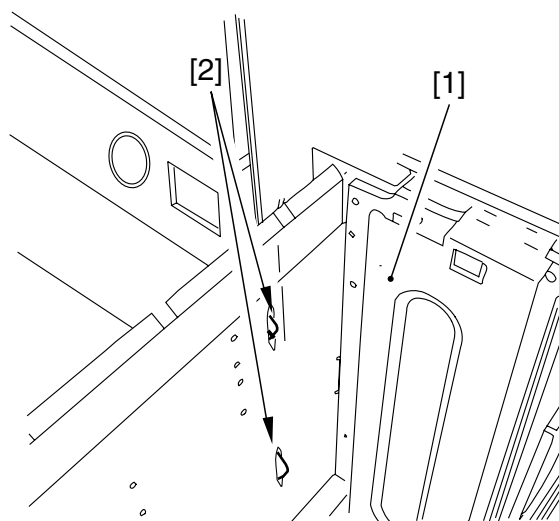

F05-501-07

- 5) Disconnect the power plug.

5.1.4 Removing the Rear Cover

- 1) Release the deck from its host machine; then, remove the 6 screws [1], and detach the rear cover [2].

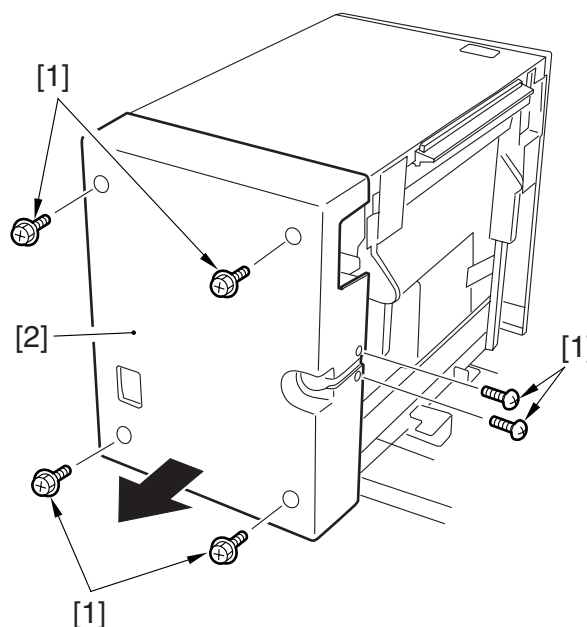

F01-501-08

5.1.5 Removing the Right Cover

- 1) Open the compartment. (See 5.1.1.)
- 2) Remove the 3 screws [1]; then, shift the right cover [2] downward, and detach it toward the front.

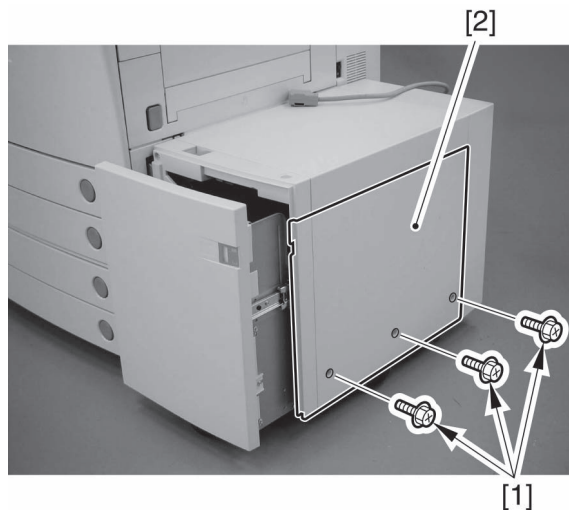

F01-501-09



To attach the right cover, fit the claw [1] of the top of the right cover in the opening [2] of the paper deck stay; then, fit the side [3] on the right behind the rear cover [4].

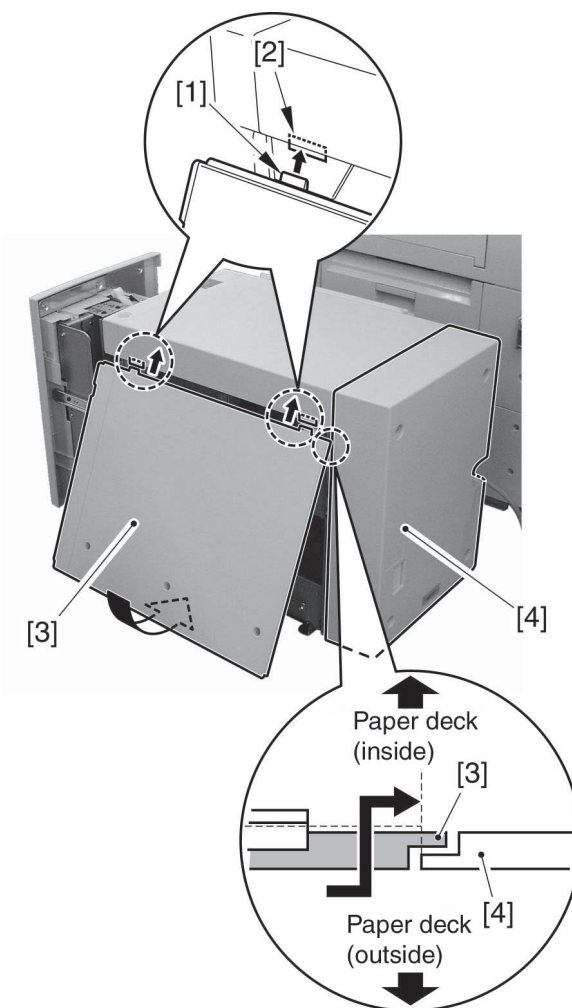

F01-501-10

5.1.6 Removing the Front Cover (upper)

- 1) Open the compartment. (See 5.1.1.)
- 2) Remove the 3 screws [1], and disconnect the connector [2]; then, detach the front cover (upper) [3].



To attach the front cover (upper), be sure that the harness to the open switch PCB is not trapped and all connectors are properly connected.

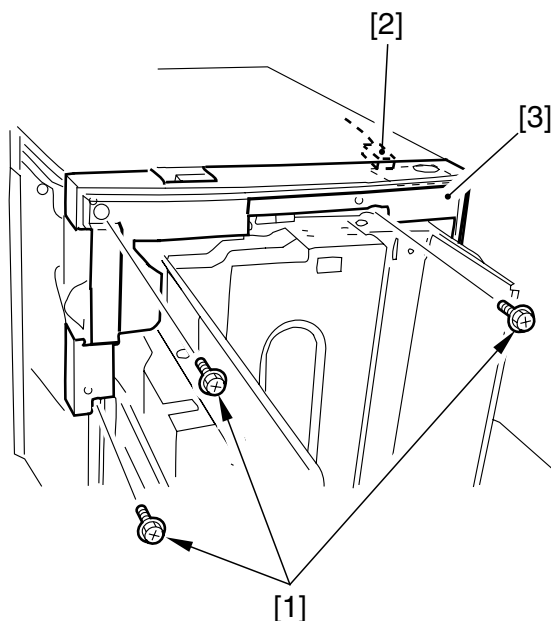

F01-501-11

5.1.7 Removing the Upper Cover

- 1) Remove the rear cover. (See 5.1.4.)
- 2) Open the compartment. (See 5.1.1.)
- 3) Remove the front cover (upper). (See 5.1.6.)
- 4) Remove the 2 screws [1], and detach the upper cover [2].

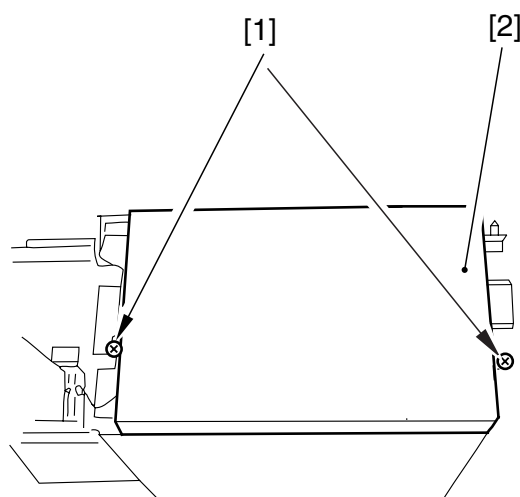

F01-501-12

5.2 Paper Deck

5.2.1 Removing the Deck from Its Host Machine

- 1) To prepare, place a stack of paper [3] (A: about 8 cm) on the floor for placement of the deck [2], thereby preventing the spacer support plate [1].

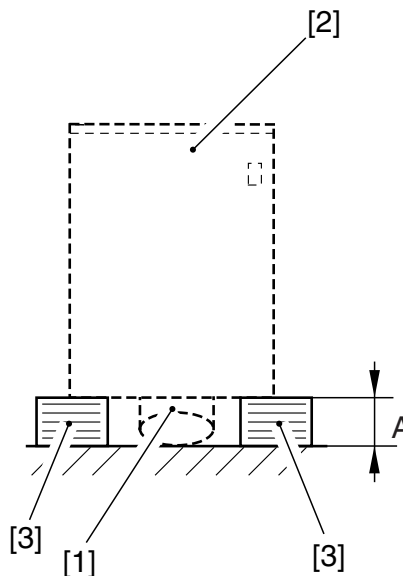

F01-502-01

- 2) Remove the right cover. (See 5.1.5.)
- 3) Remove the 2 screws [1] from the right side.

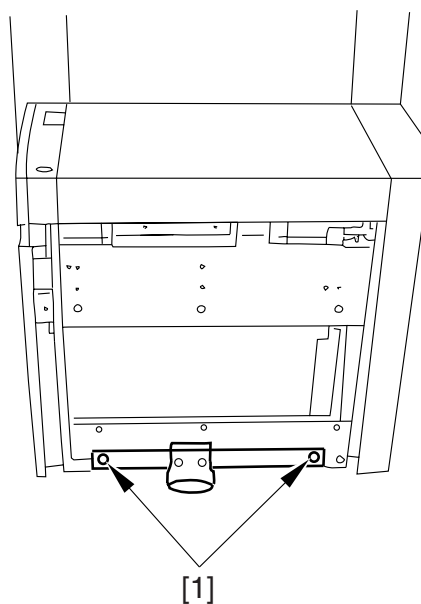

F01-502-02

- 4) Remove the 2 screws [1] from the left, and detach the deck [2] from the deck base [3].

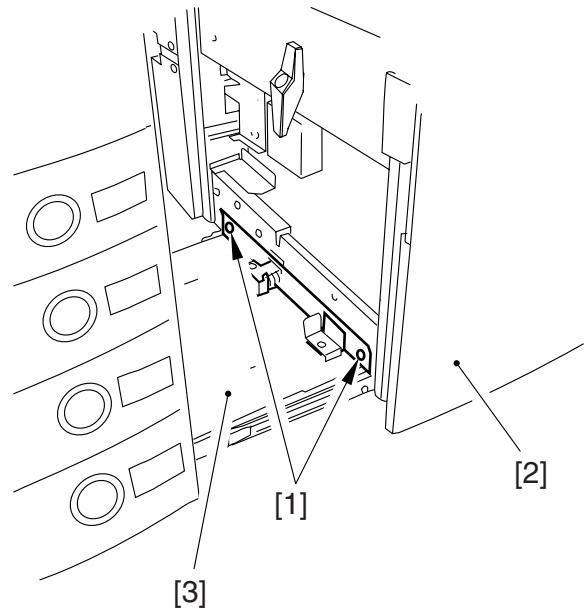

F01-502-03

- 5) Holding the deck [1] by the areas indicated in the figure, place it on the stack of paper you have prepared.

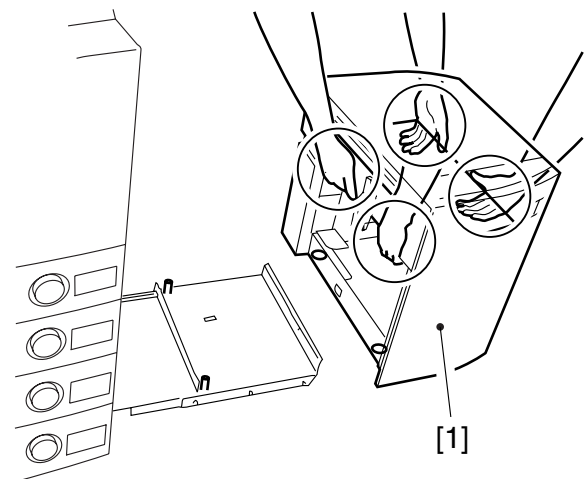

F01-502-04

5.2.2 Removing the Compartment

- 1) To prepare, place a stack of paper [3] (A: about 8 cm) on the floor for placement of the deck [2], thereby preventing the spacer support plate [1].

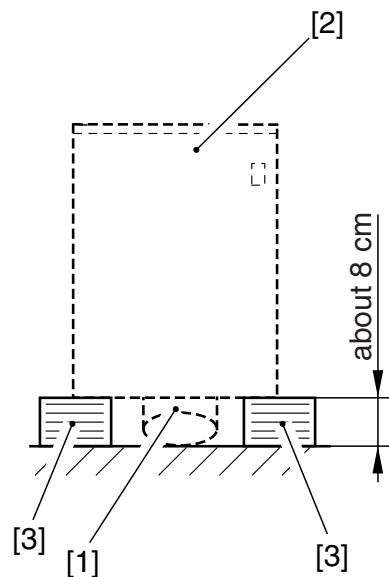

F01-502-05

- 2) Open the compartment. (See 5.1.1.)
- 3) Remove the right cover. (See 5.1.5.)
- 4) Disconnect the connector [1] and remove the screw [2] from the rear, and detach the harness unit [3].

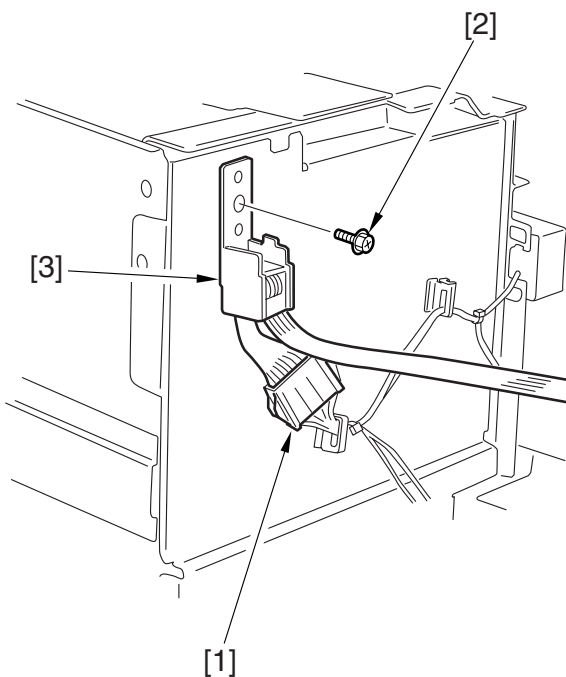

F01-502-06

- 5) Remove the screw [1] and the stopper plate [2] from the left rear of the deck; then, slide the compartment [2] farther to the front.

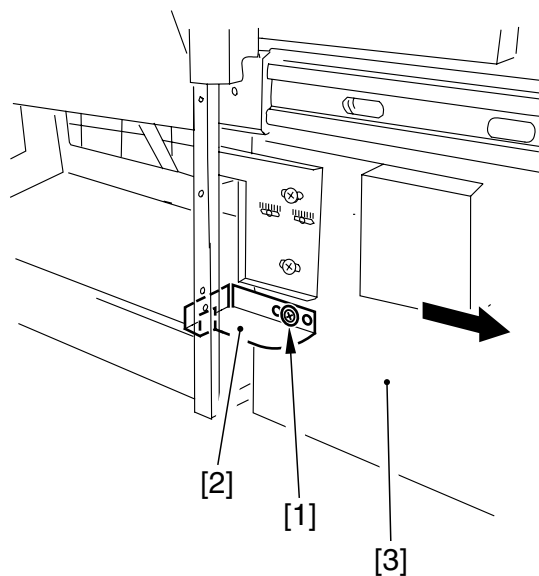

F01-502-07

- 6) Remove the 3 screws [2] each from the left and right of the compartment rail [1]; then, lift the compartment [3] about 1 cm, and detach it toward the front.
- 7) Place the compartment [3] on the stack of paper you have previously prepared.

Be sure to place it on the stack of paper to prevent deformation of the spacer support laser.

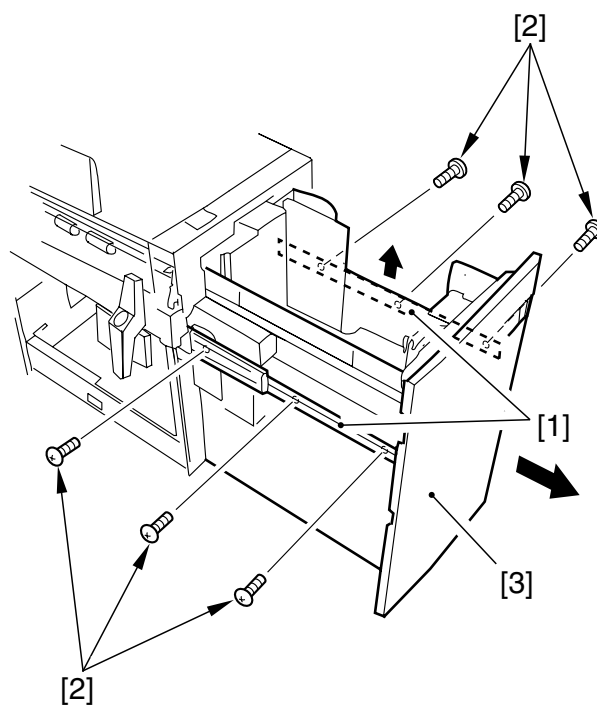

F01-502-08

5.2.3 Changing the Deck Paper Size

As needed to suit the user's needs, go through the following to change the deck paper size:

- 1) Remove the front cover. (See 5.1.2.)
- 2) If the lifter is up, move it to its lower limit. (See 5.1.3.)
- 3) Remove the screw [1], and fit the paper trailing edge guide plate [2] to suit the new paper size. (Do not perform this step if for LTR.)
- 4) Remove the screw [3] (1 each), and fit the left/right guide plate [4] to suit the new paper size.

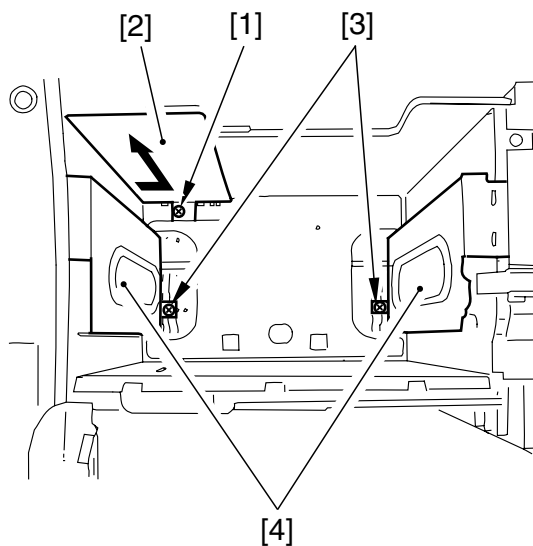

F01-502-09

5.2.4 After Changing the Deck Paper Size

Execute 'machine specifications selection' in source mode to set p the new paper size.



COPIER>OPTION>ACC>DK-P
machine specifications selection

5.2.5 Checking the Image Rear/Front Position for Pickup from the Side Paper Deck

Make a 100% copy, and check to make sure that the margin on the front of the image is 2.0 ± 1.0 mm; if not, adjust the registration. (See 5.2.6.)

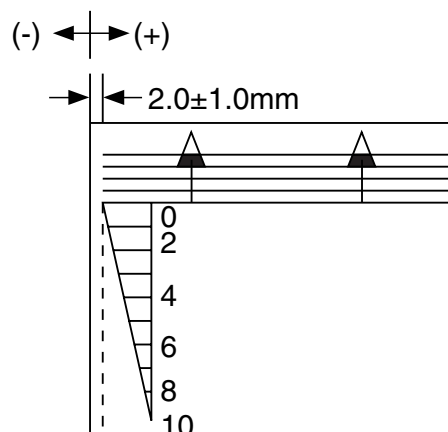

F01-502-10

5.2.6 Adjusting the Rear/Front Registration for the Side Paper Deck

- 1) Slide out the compartment. (See 5.1.1.)
- 2) Adjust the latch plate [1] of the deck open solenoid (SL2D) found at the left rear using the 2 screws [2].



At this time, use the indexes on the latch plate as a reference.

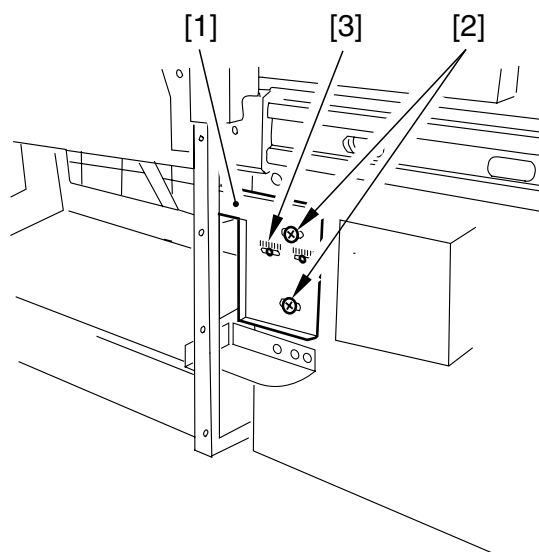

F01-502-11

- 3) Close the compartment, and check to make sure that the gap of the front cover is 3 ± 1 mm.
- 4) If not 3 ± 1 mm, adjust the front cover. (See 5.1.2)

5.2.7 Adjusting the Position of the Spacer

If the compartment cannot be opened/closed smoothly and, thus, requires adjustment of the spacer mounted to the front of the deck, go through the following:

- 1) Remove the front cover. (See 5.1.2.)
- 2) With the compartment set in the deck, turn the 4 mounting screws [4] of the spacer support plate [3] so that the distance A between the spacer [1] and the floor [2] is about 5 mm.



At this time, use the index [5] on the front side plate as a reference.

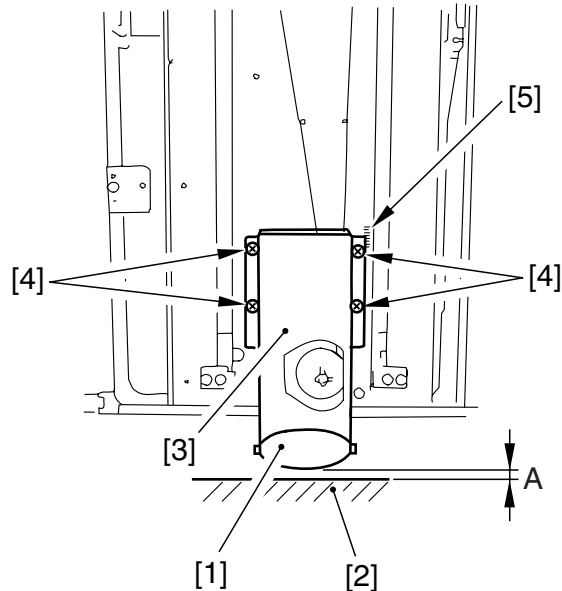

F01-502-12

5.2.8 Adjusting the Height of the Side Spacer

a. Before Starting the Work

- 1) Slide the machine out of its host machine, and then slide it back in. Check to see if the impact of the movement has displaced the host machine or if the machine has wobbled. If so, adjust the height of the side spacer; otherwise, this adjustment may be skipped.

b. Making Adjustments

- 1) Connect the machine to its host machine.
- 2) Remove all paper from the deck.
- 3) Remove the machine's right cover.
- 4) Loosen the 2 fixing screws [2] of the side spacer [1].
- 5) Bring the side spacer in contact with the floor, and tighten the fixing screw.



At this time, refer to the indexes so that the left and right screws are at the index.

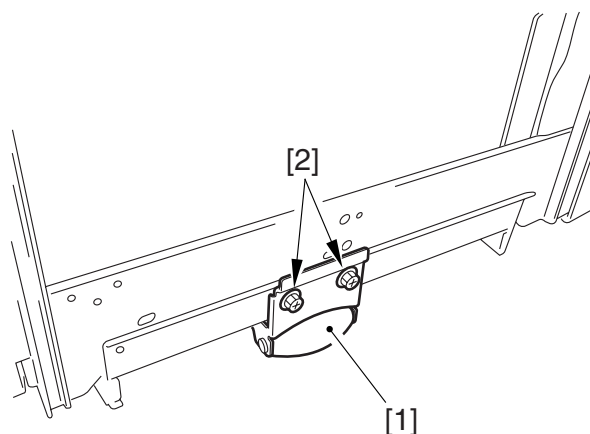

F01-502-13

- 6) Disconnect and then connect the machine from and to its host machine. If the movement is not heavy, attach the machine's right cover, put paper back in, and then end the work. If the movement is heavy, go to the next step.
- 7) Check the index of the side spacer.
- 8) Loosen the side spacer fixing screw.
- 9) By referring to the index, move the side spacer up by 1 mm; then, tighten the fixing screw.
- 10) Attach the right, and put paper in the deck.

5.3 Drive Mechanisms

5.3.1 Removing the Deck Pickup Clutch (CL2D)

- 1) Remove the deck pickup unit. (See 5.4.1.)
- 2) Disconnect the connector [1], and remove the E-ring [2]; then, remove the deck pickup latch [3].



To mount the deck pickup clutch, be sure to put the clutch to the stop [4]. Moreover, be sure to hook the harness on the U-groove [5] of the guide.

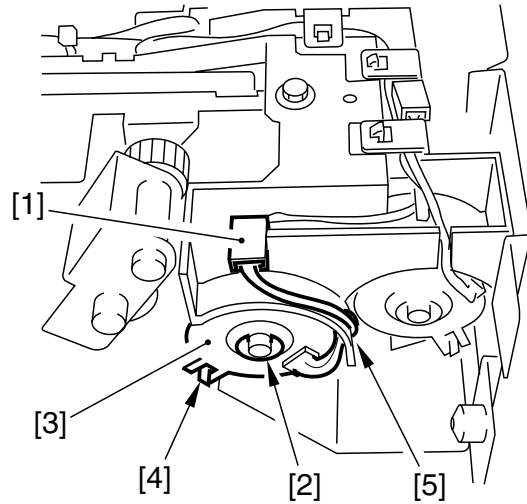

F01-503-01

5.3.2 Removing the Deck Feeding Clutch (CL1D)

- 1) Remove the deck pickup unit. (See 5.4.1.)
- 2) Remove the harness retainer [1], disconnect the connector [2], and remove the E-ring [3]; then, detach the deck feeding clutch [4].



To mount the deck feeding clutch, be sure to fit the clutch to the stop [5].

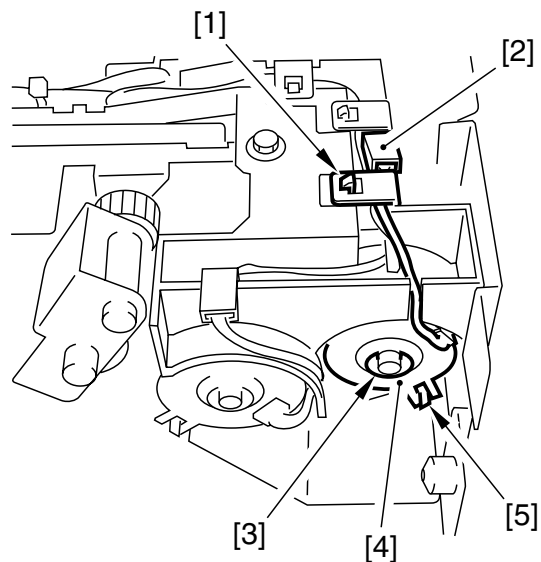

F01-503-02

5.3.3 Removing the Deck Main Motor (M1D)

- 1) Remove the rear cover. (See 5.1.4.)
- 2) Disconnect the connector [1], and the 2 screws; then, detach the deck main motor [3].



At this time, take care not to damage the gear found at the tip of the motor spindle.

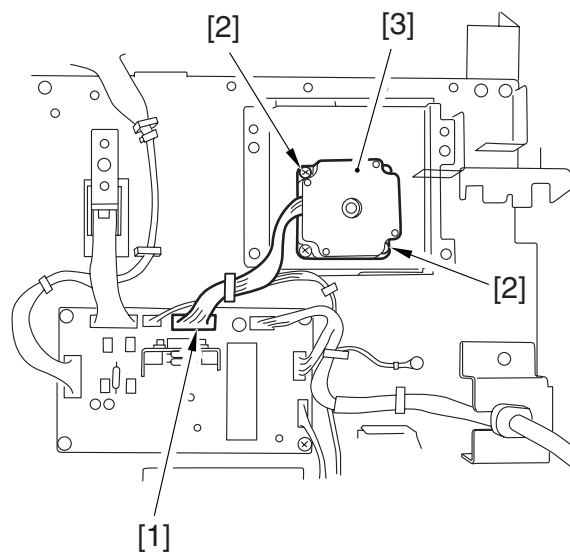

F01-503-03

5.3.4 Removing the Deck Lifter Motor (M2D)

- 1) Open the compartment. (See 5.1.1.)
- 2) If the deck lifter [1] is up, move it so that distance A from the compartment bottom plate of the deck lifter is about 7 cm. (See 5.1.3.)
- 3) Fit a hex wrench in the hole into the lifter drive shaft [2] to keep the lifter drive shaft [2] in place (preventing it from turning).

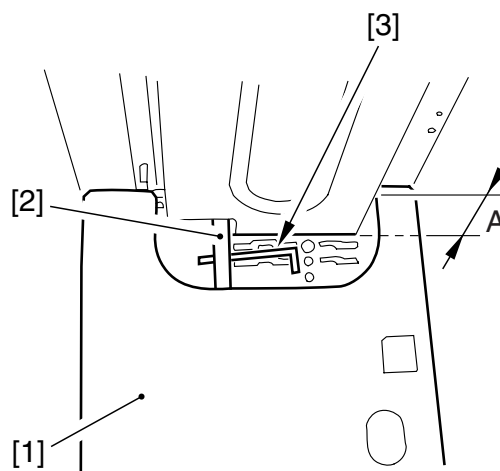

F01-503-04

- 4) Take out the compartment. (See 5.2.2.)
- 5) Disconnect the connector [1], and remove the 5 screws [2]; then, detach the deck lifter motor unit [3].

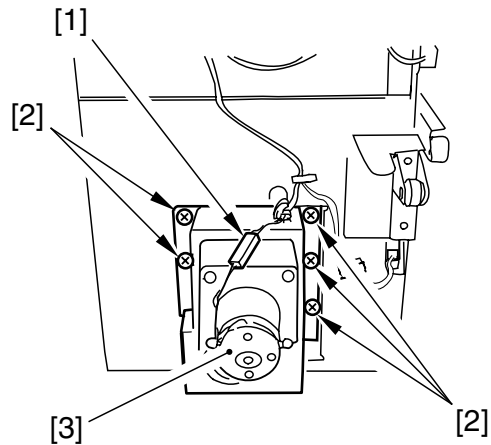

F01-503-05

5.3.5 Removing the Lifter Cable (front of deck)

- 1) Open the compartment. (See 5.1.1.)
- 2) Remove all paper, if any.
- 3) Remove the screw [2], and detach the paper trailing edge guide plate [1] from inside the compartment.

If the paper size is set to LTR, the paper trailing edge guide is not used.

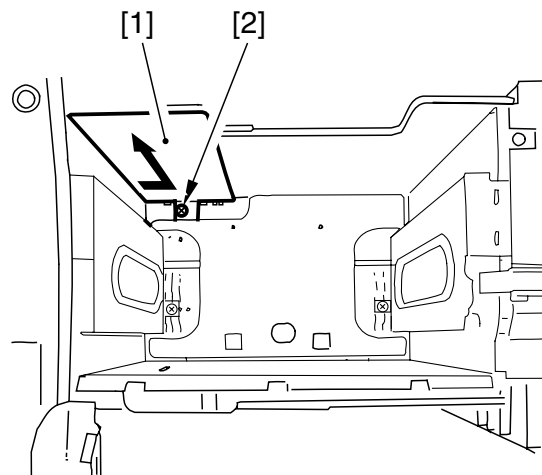

F01-503-06

- 4) So that the holes on the right and left of the compartment size plate and the holes of the right and left of the lifter match, push the flag [1] of the paper supply position sensor with a finger to move down the lifter. (See 5.1.3.)
- 5) To position the lifter, fit 2 long screwdrivers [3] as shown.

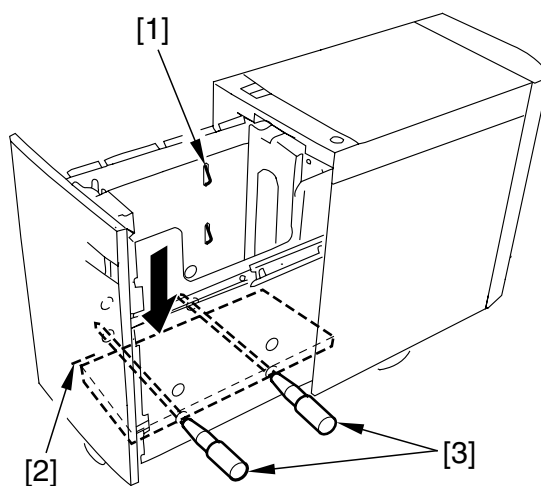

F01-503-07

- 6) Remove the front cover of the deck. (See 5.1.2.)
- 7) Remove the 4 screws [1], and detach the spacer support plate [2].

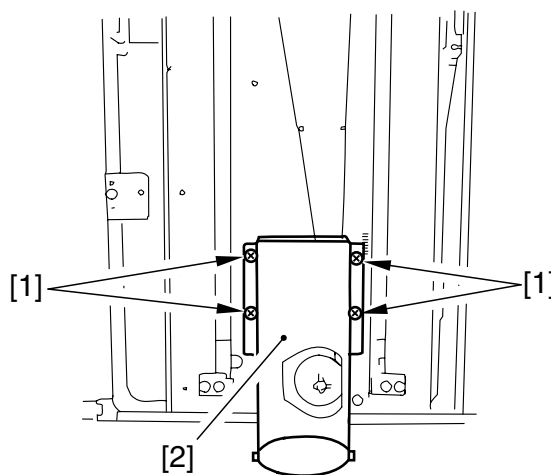

F01-503-08

- 8) Remove the coupling shaft [1] and the E-ring [2]; then, detach the pulley cover [3].
- 9) Remove the 2 screws [4] and the cable fixing plate [5] on the left side; then, detach the lifter cable [6] on the outside.
- 10) Remove the 2 screws [7] and the cable fixing plate [8] on the right side; then, detach the lifter cable [8] on the inside.
- 11) To free the lifter cable [9] of the inside from the pulley [10] on the outside, remove the 2 set screws [12], and detach the pulley [11] of the outside.

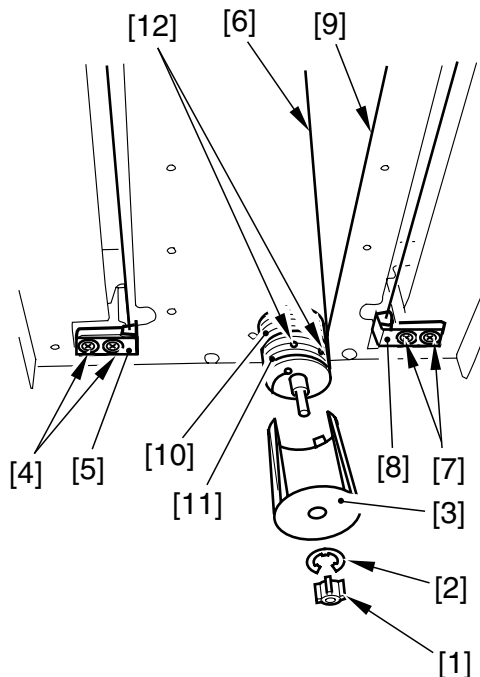

F01-503-09

5.3.6 Removing the Lifter Cable (rear of deck)

- 1) Open the compartment. (See 5.1.1.)
- 2) Remove all paper, if any.
- 3) Remove the screw [2], and detach the paper trailing edge guide plate [1] from inside the compartment.
- 4) Remove the compartment. (See 5.2.2.)
- 5) Remove the screw [1] (1 each), and detach the upper [2] and lower [3] covers.
- 6) Disconnect the 4 connectors [4].

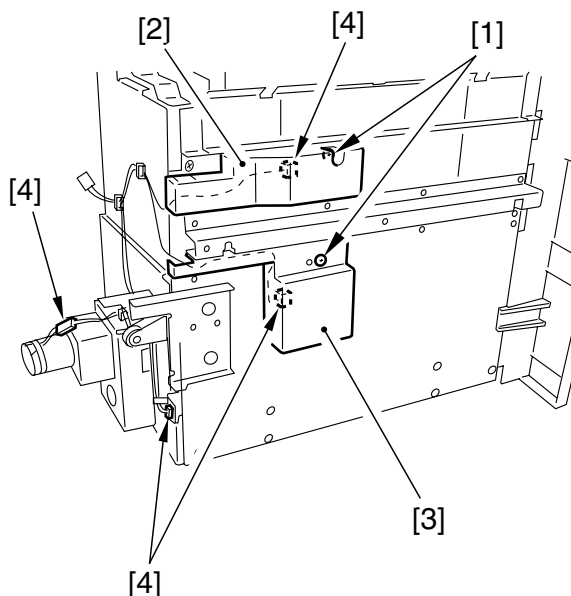

F01-503-10

- 7) Remove the screw [1], and detach the sensor plate [2].
- 8) Remove the 5 screws [3], and detach the plate [4].

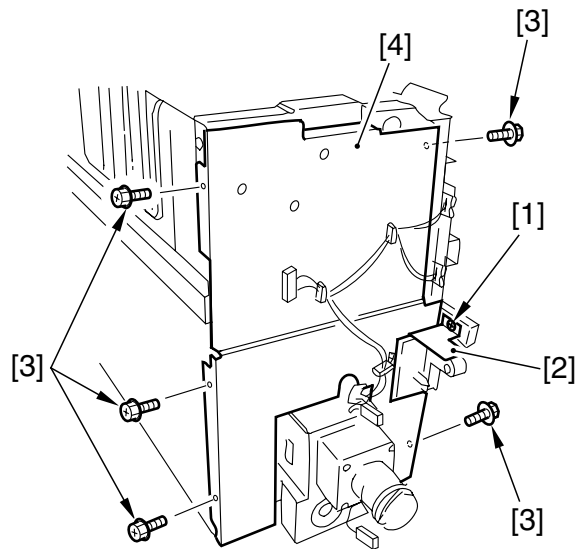

F01-503-11

- 9) Fit a hex wrench [2] in the hole of the lifter drive shaft [1] to keep it in place (from turning).



If you fail to keep the lifter drive shaft in place, the cable will become slack when you remove the lifter motor unit.

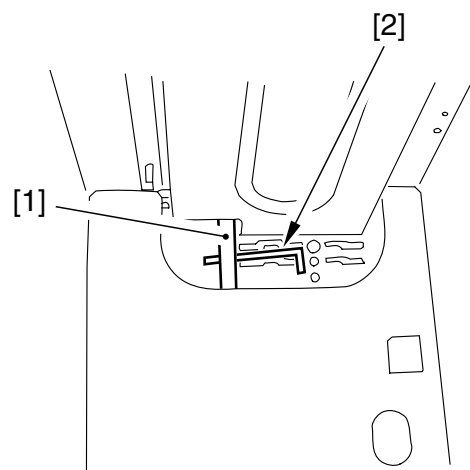

F01-503-12

- 10) Remove the 5 screws [1], and detach the lifter motor unit [2].

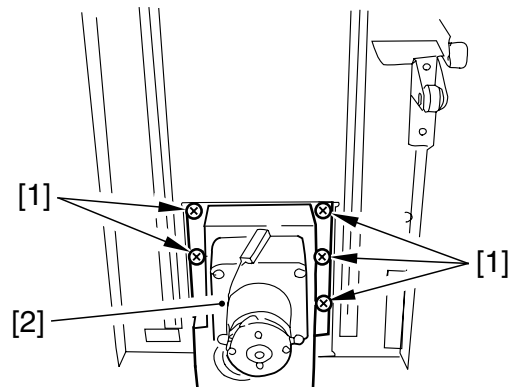

F01-503-13

5.3.7 Routing the Lifter Cable

- 1) Before starting the work, check to see that the lifter drive shaft [1] and the lifter [2] are kept in place with a hex wrench [3] and 2 long screwdrivers [4], respectively.
- 2) Secure the 4 cable fixing plates [5] with 2 screws each to the lifter.
- 3) Hook the lifter cable [7] on the 4 pulleys [7] above them.
- 4) Hook the ball of the lifter on the 2 pulleys [8] at the front/rear of the lifter shaft; then, wind it about 1.5 times along the groove of the pulley by hand.

At this time, make sure that the lifter cable is taut with the long screwdrivers (used to keep the lifter in place) being lightly pulled by the lifter cable.

- 5) In this condition, secure the 2 pulleys [5] in place to the lifter drive shaft with a set screw [9] (1 each).
- 6) After securing all pulleys you have removed in place to the lifter drive shaft, measure the distance from the base plate of the compartment to the top surface of the lifter at several points, thereby making sure that the lifter is level.

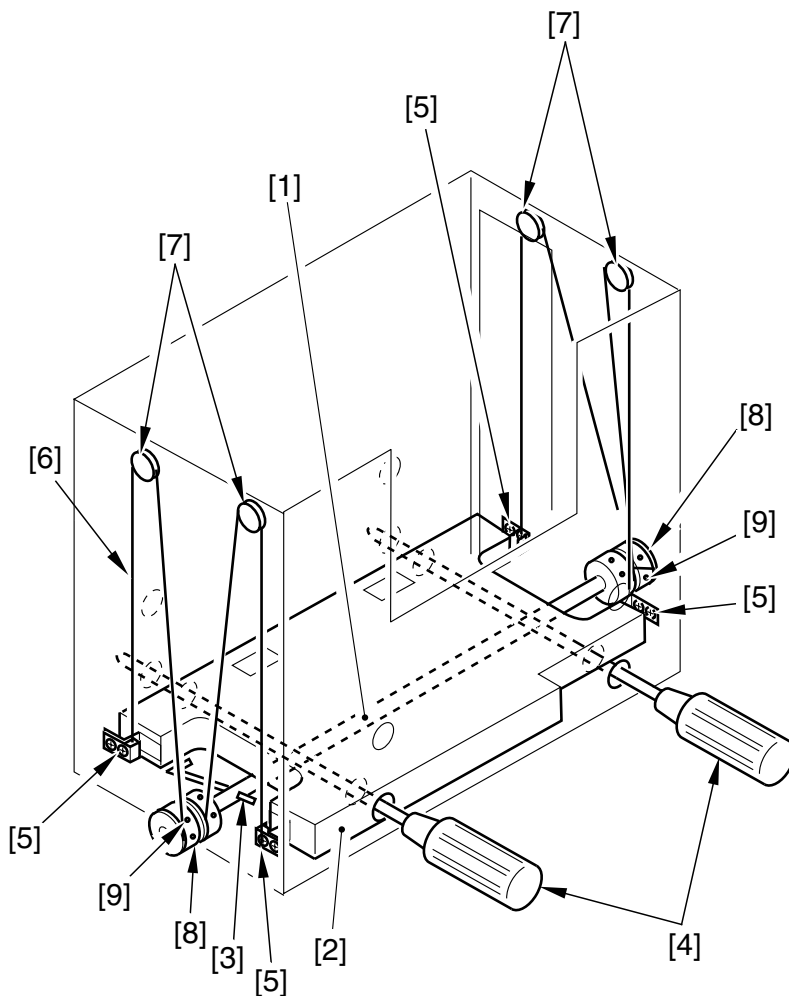

F01-503-14

5.4 Feeding System

5.4.1 Removing the Deck Pickup Unit

- 1) Remove the upper cover. (See 5.1.7.)
- 2) Remove the deck releasing grip [1].
- 3) Disconnect the 2 connectors [2], and remove the 5 screws [3]; then, detach the deck pickup unit [4].

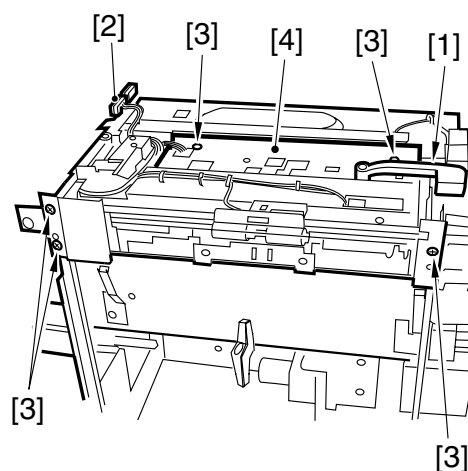

F01-504-01



To mount the deck pickup unit [1], be sure to fit the 3 screws [2] in place in advance.

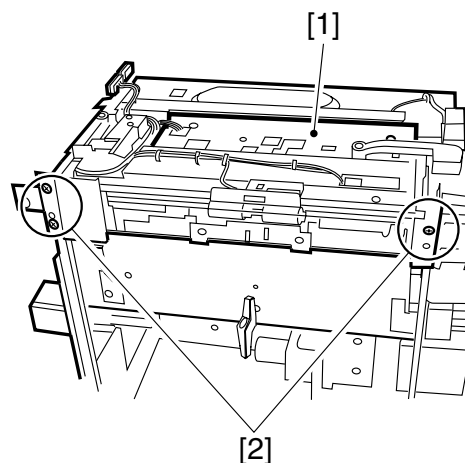

F01-504-02

5.4.2 Removing the Deck Pickup Roller

- 1) Remove the deck pickup unit. (See 5.4.1.)
- 2) Turn over the deck pickup unit; then, remove the resin ring [1] (1 each), and remove the 2 deck pickup roller [2].



The deck pickup roller has a specific orientation, requiring care.

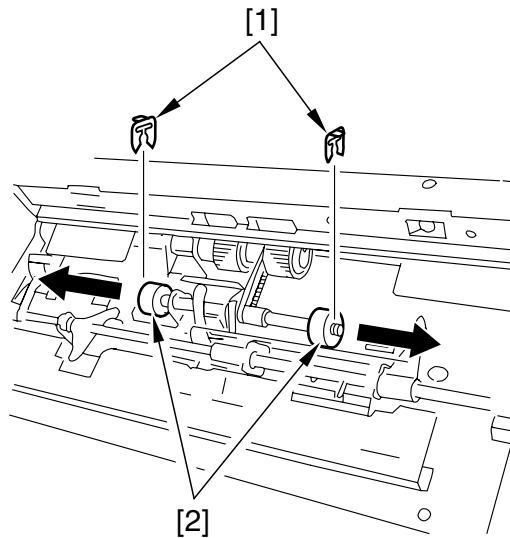

F01-504-03

5.4.3 Orientation of the Deck Pickup Roller

Front (collar [3]: silver-colored)

The roller rotates in one direction only [1]. When mounting the deck pickup roller [2] at the front of the machine, be sure that the marking [4] on the collar [3] is toward the rear of the machine.

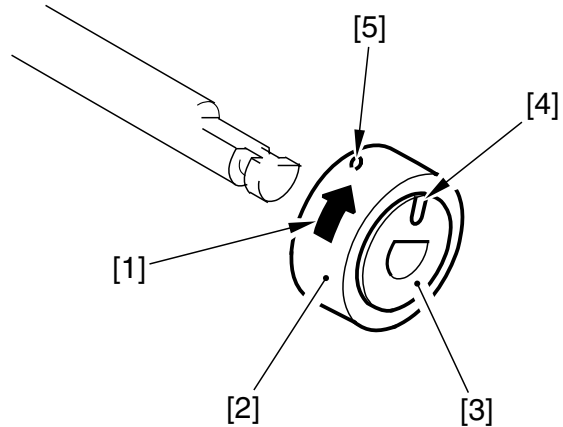

F01-504-04

Rear (collar [3]: gold-colored)

The pickup roller rotates in one direction only [1]. When mounting the deck pickup roller [2] to the rear of the machine, be sure that the marking [4] on the collar [3] and the marking [5] on the side of the roller are toward the rear of the machine.

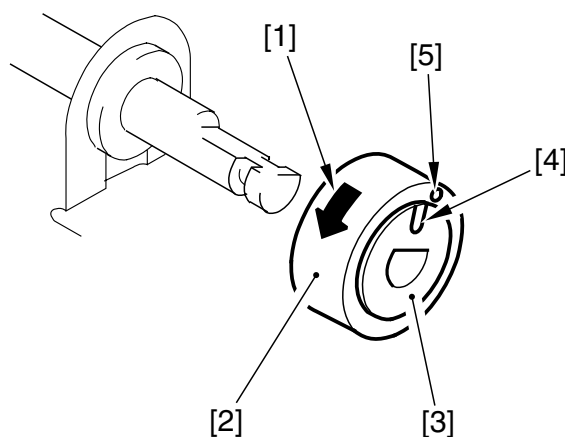

F01-504-05

5.4.4 Removing the Deck Pickup/Feeding Roller

- 1) Remove the deck pickup unit. (See 5.4.1.)
- 2) Turn over the deck pickup unit.
- 3) Remove the resin ring [1], and detach the deck pickup/feeding roller [2] and the drive belt [3] toward the front.

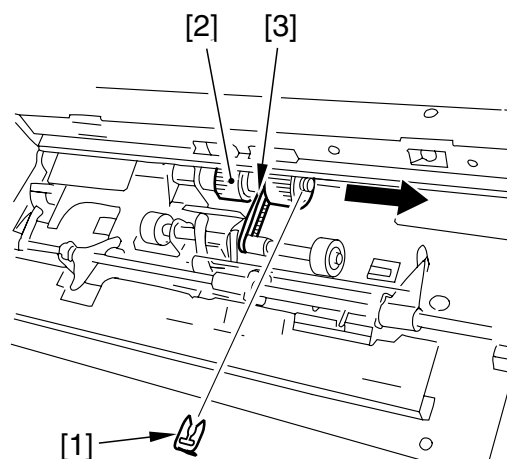

F01-504-06

5.4.5 Orientation of the Deck Pickup/Feeding Roller

When mounting the deck pickup/feeding roller [1], be sure that the belt pulley [2] is toward the front of the machine. The pickup/feeding roller rubber piece may be attached to the pickup/feeding roller shaft in any orientation.

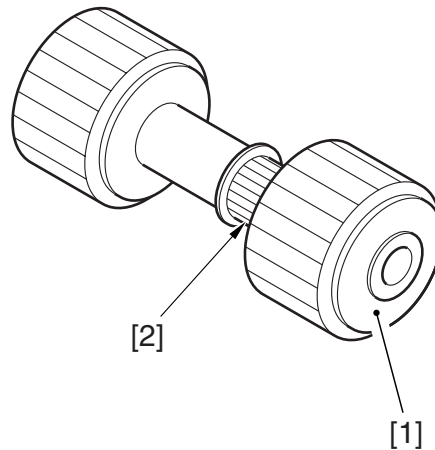

F01-504-07

5.4.6 Removing the Deck Separation Roller

- 1) Detach the deck from its host machine; then, remove the 2 screws [1], and detach the separation roller support plate [2].

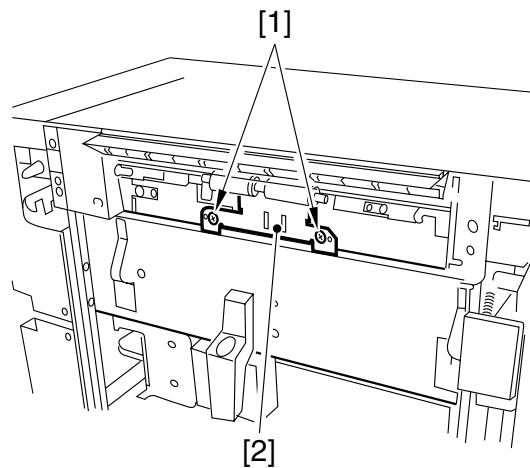

F01-504-08

- 2) Remove the joint [1], and detach the deck separation roller [2].

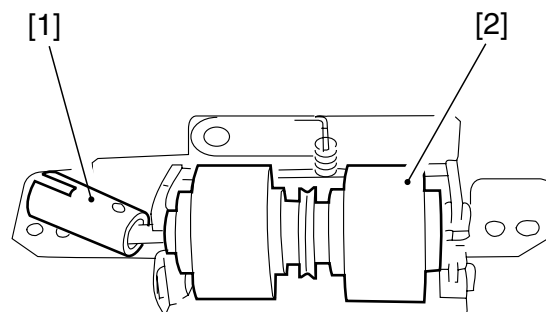

F01-504-09



The urethane sponge used for the deck separation roller is pink immediately after foaming; however, over time, it will change from pink to orange and then to yellow (more conspicuously when exposed to light). This is a characteristic of urethane sponge, and there is no difference in performance in relation to its color. (It does not come in different colors.)

5.4.7 Adjusting the Deck Separation Roller Pressure

If double feeding or pickup faults occur when the deck is used as the source of paper, change the position of the pressure spring [2] of the deck separation roller [1].

- If a pickup fault occurs, move the spring in the direction of arrow A.
- If double feeding occurs, on the other hand, move the spring in the direction of arrow B.

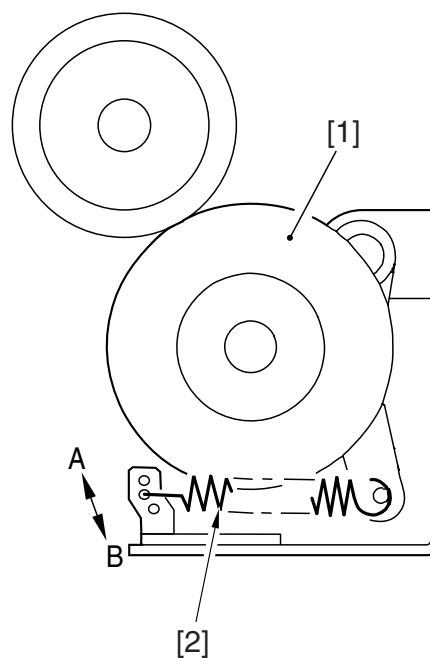

F01-504-10

5.4.8 Position of the Deck Pickup Roller Releasing Solenoid (SL1D)

Before removing the deck pickup roller releasing solenoid [1] from the support plate, take mental note of the position of the 2 fixing screws [2] with reference to the index on the support plate. Or, mark the position of the solenoid on the support with a scribe. When mounting the solenoid on its own, secure it in place to its initial position.

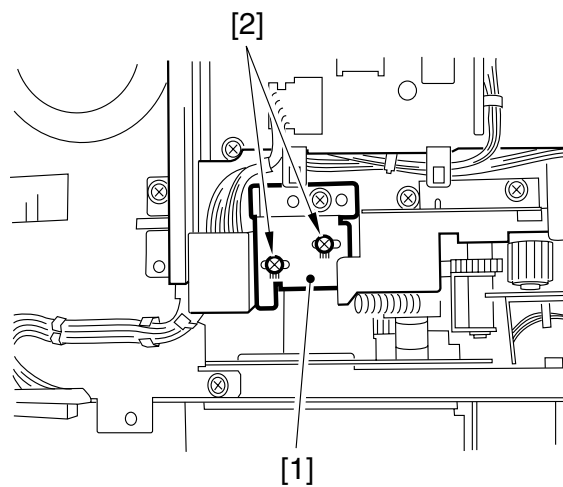

F01-504-11

5.5 Electrical Mechanisms

5.5.1 Removing the Deck Driver PCB

- 1) Remove the rear cover. (See 5.1.4.)
- 2) Disconnect the 7 connectors [1], and remove the 4 screws [2]; then, detach the deck driver PCB [3].

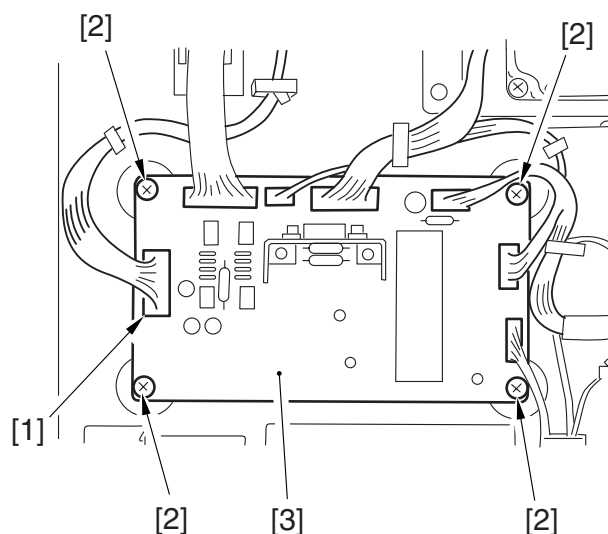

F01-505-01

5.5.2 Removing the Open Switch PCB

- 1) Remove the front cover (upper). (See 5.1.6.)
- 2) Remove the 2 screws [2] from the inside of the front cover (upper) [1]; then, detach the open switch PCB [3].

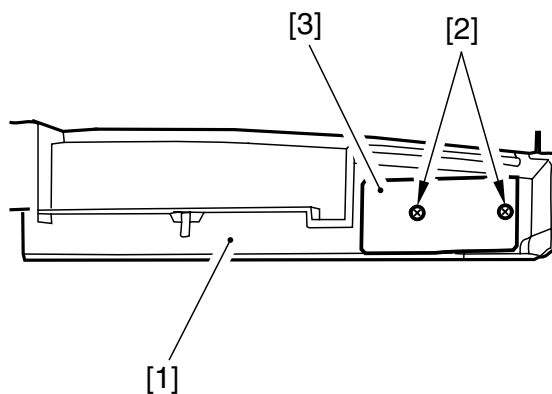

F01-505-02

CHAPTER 2

2-CASSETTE PEDESTAL

1 Cassette Pedestal-X1

1.1 Outline

Item	Specifications	Remarks
Method of paper accommodation	Front loading	
Method of pickup	Separation retard	
Number of cassettes	2 (cassette 3/4)	Cassettes 3/4 used in common with cassette 1/2 of host machine
Size setting	By user	
Type of paper	Plain paper, thick paper, transparency	64 g/m ² to 209 g/m ²
Size of paper	A3, A4, A4R, B4, B5, B5R, A5R, 12 × 18 (305 × 457 mm), 11 × 17 (279 × 432 mm), LGL, LTR, LTRR, STMTR	
Volume of paper	550 sheets (paper of 80 g/m ²)	
Environmental considerations	Yes	Cassette heater (option)
Power supply	Yes	Options power supply (built-in)
Dimensions	620 (W) × 705 (D) × 312 (H) mm	
Weight	30 kg (approx.)	
Maximum power consumption	100 W	

1.2 Construction

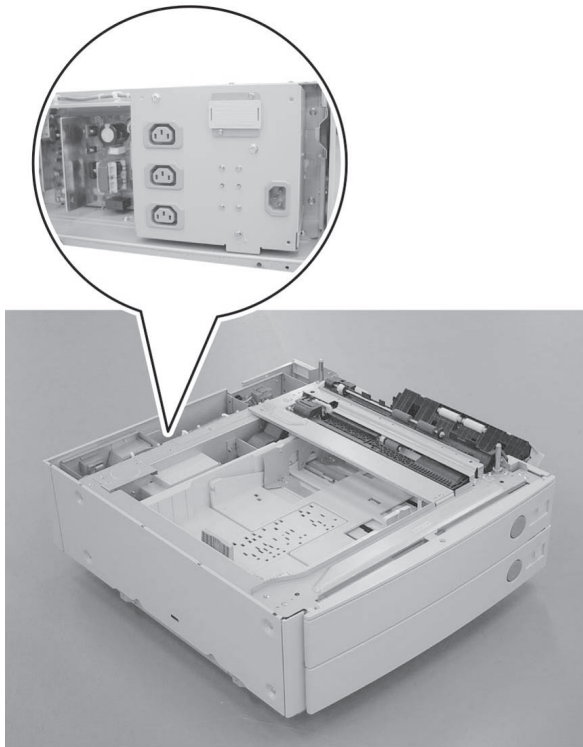

F02-102-01

1.3 Arrangement of Sensors

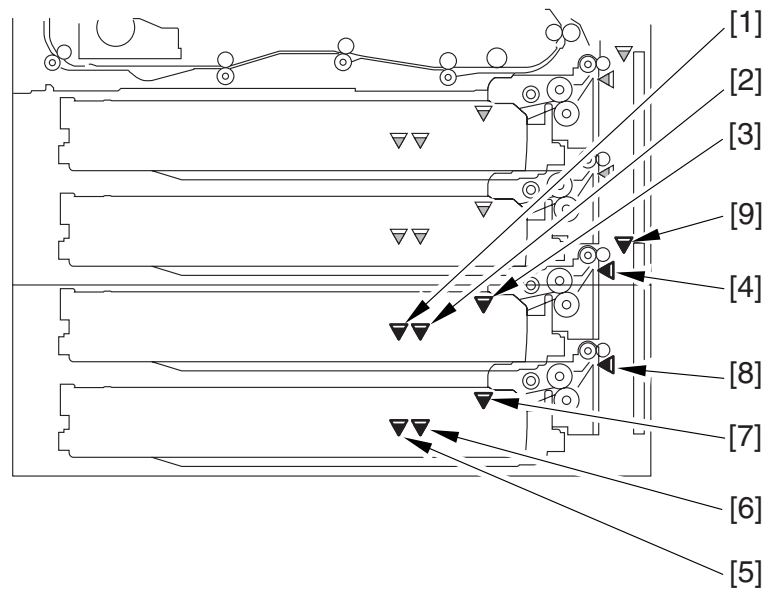

F02-103-01

- [1] Cassette 3 paper level sensor B (PS51)
- [2] Cassette 3 paper level sensor A (PS52)
- [3] Cassette 3 retry paper sensor (PS53)
- [4] Cassette 3 paper sensor (PS54)
- [5] Cassette 4 paper level sensor B (PS55)
- [6] Cassette 4 paper level sensor A (PS56)
- [7] Cassette 4 retry paper sensor (PS57)
- [8] Cassette 4 paper sensor (PS58)
- [9] Pedestal right cover open/closed sensor (PS59)

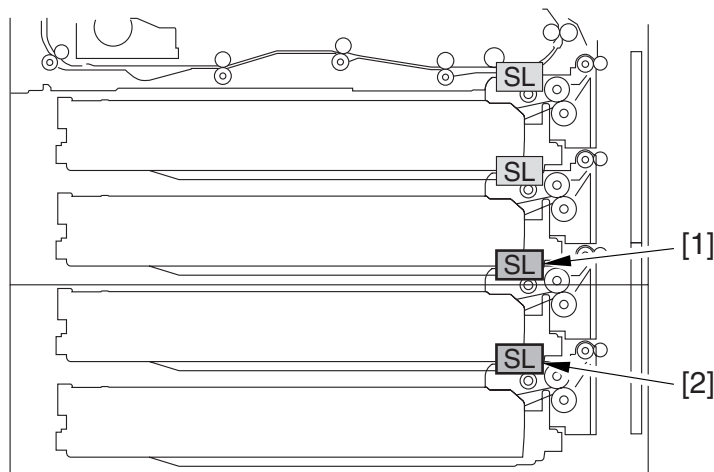

F02-103-02

[1] Cassette 3 pickup solenoid (SL51)

[2] Cassette 4 pickup solenoid (SL52)

1.4 Options Power Supply

See Printer Unit>Chapter 7 Externals and Controls>4. Power Supply.

2 Detecting Jams

2.1 Delay Jams

See Printer Unit>Chapter 5 Pickup/Feeding System>2. Detecting Jams>2.1 Delay Jams.

2.2 Stationary Jams

See Printer Unit>Chapter 5 Pickup/Feeding System>2. Detecting Jams>2.2 Delay Jams.

3 Pickup Unit/Cassette

3.1 Pickup Control System

3.2 Outline

See Printer Unit>Chapter 5 Pickup/Feeding System>3. Cassette Pickup Unit>3.1 Outline.

3.3 Sequence of Pickup Operations

See Printer Unit>Chapter 5 Pickup/Feeding System>3. Cassette Pickup Unit>3.2 Sequence of Basic Operations.

3.4 Identifying the Size of Paper

See Printer Unit>Chapter 5 Pickup/Feeding System>4. Cassette>4.1 Identifying the Size of Paper.

3.5 Identifying the Level of Paper

See Printer Unit>Chapter 5 Pickup/Feeding System>4. Cassette>4.2 Identifying the Level of Paper.

3.6 Identifying the Size of Paper

See Printer Unit>Chapter 5 Pickup/Feeding System>4. Cassette>4.1 Identifying the Size of Paper.

4 Disassembly/Assembly

4.1 External Covers

- [1] Left cover
- [2] Left front cover
- [3] Right front cover
- [4] Right rear cover
- [5] Rear cover
- [6] Pedestal right cover

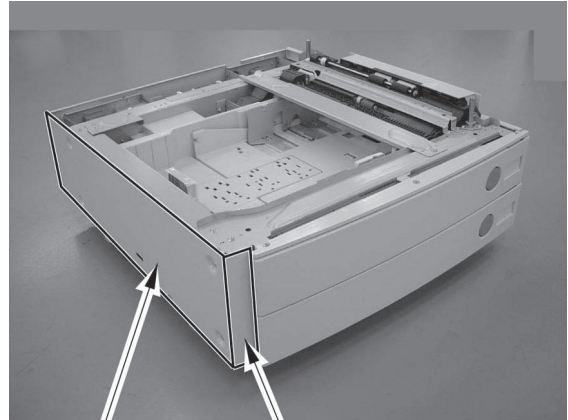

[1] [2]

F02-401-01

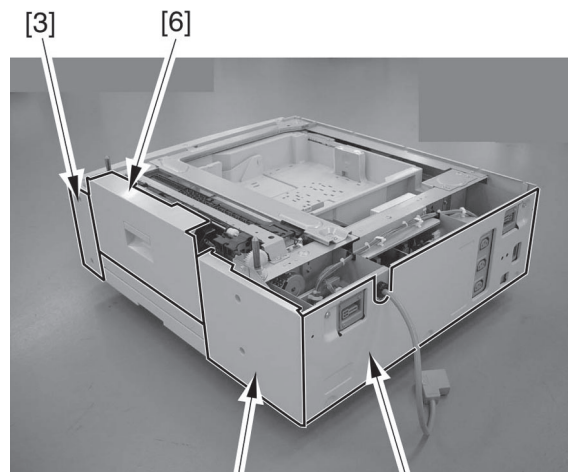

[3] [6]
[3] [5]

F02-401-02

4.2 Removing the Pedestal Right Cover Open/Closed Sensor

- 1) Slide out the cassette.
- 2) Open the pedestal right cover.
- 3) Remove the 2 screws [1], and detach the right front cover [2].

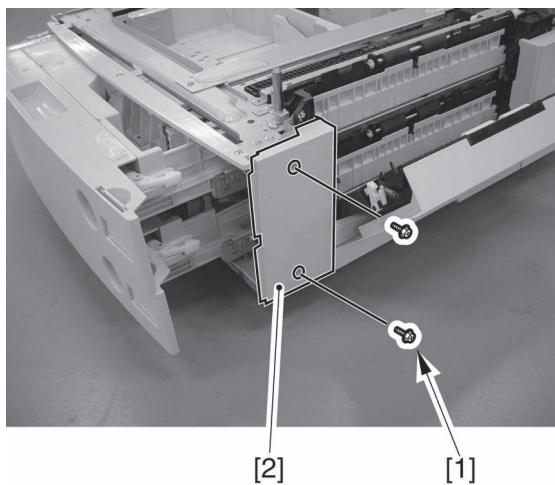

F02-402-01

- 4) Disconnect the connector [1], and remove the screw [2]; then, detach the sensor mounting plate [3].

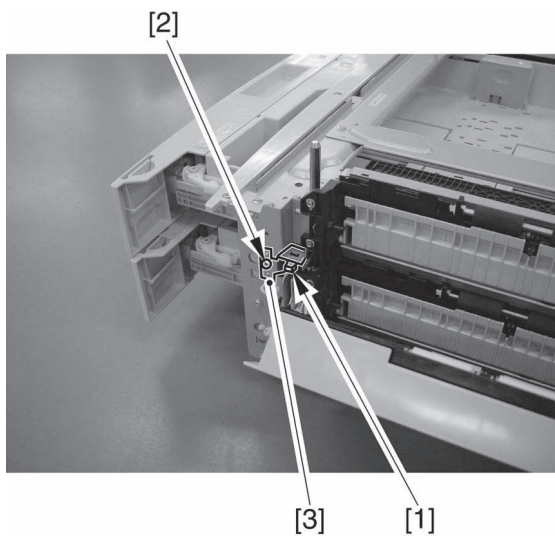

F02-402-02

- 5) Remove the spring [1], and free the claw; then, detach the sensor flag [2].

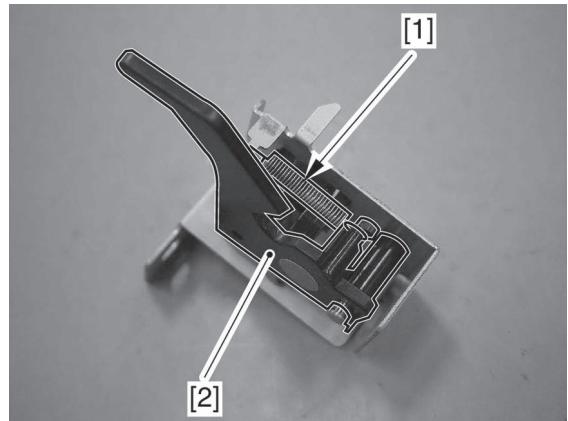

F02-402-03

- 6) Remove the pedestal right cover open/closed sensor [2] for the sensor mounting plate [1].

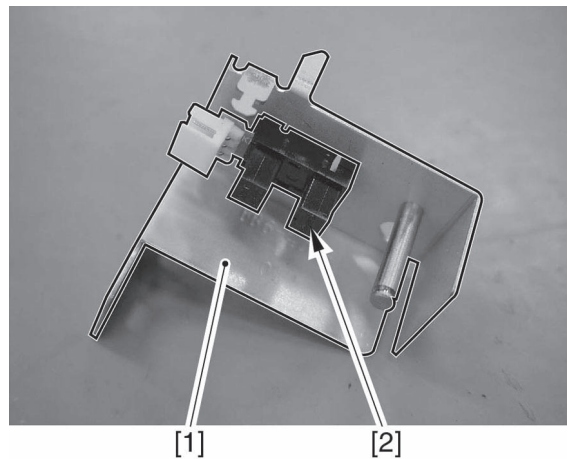

F02-402-04



To mount the right front cover, be sure that the sensor flag [1] matches the cut-off A.

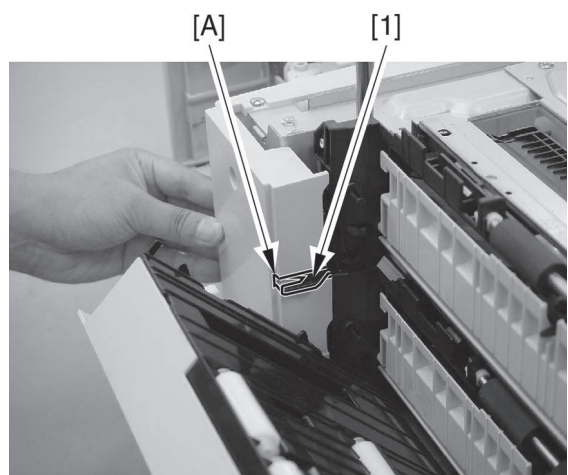

F02-402-05

4.3 Removing the Cassette Size Detection Unit

- 1) Slide out the cassette.
- 2) Remove the 4 screws [1], and detach the left cover [2].

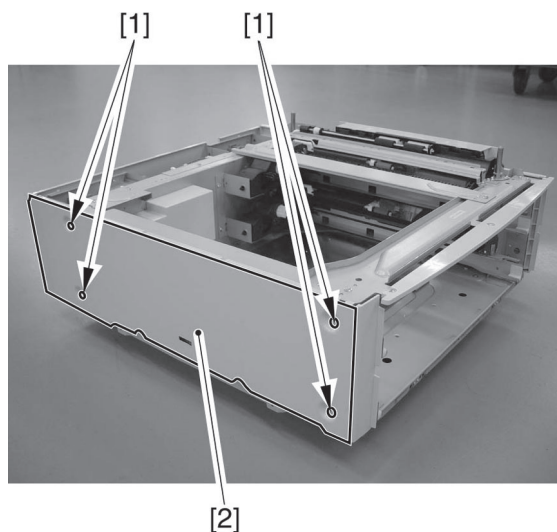

F02-403-01

- 3) Disconnect the connector [1], and push the protrusion A from the left to release the lock; then, detach the cassette size detection unit [2] from the front of the machine.

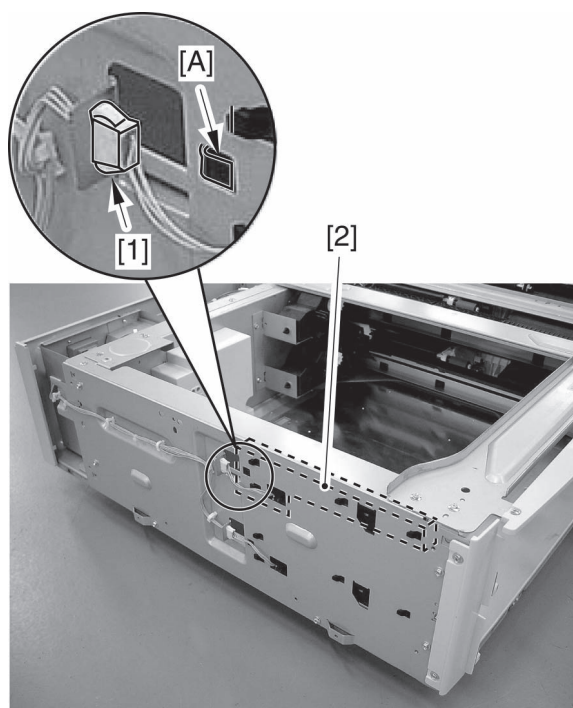

F02-403-02



Work as if to push the 4 protrusions of the cassette size detection unit into the holes in the stay on the machine side. The cassette 2 size detection unit can also be removed using the same steps used for the cassette 2 size detection unit.

4.4 Removing the Power Supply PCB

- 1) Remove the 5 screws, and detach the pedestal rear cover [2].

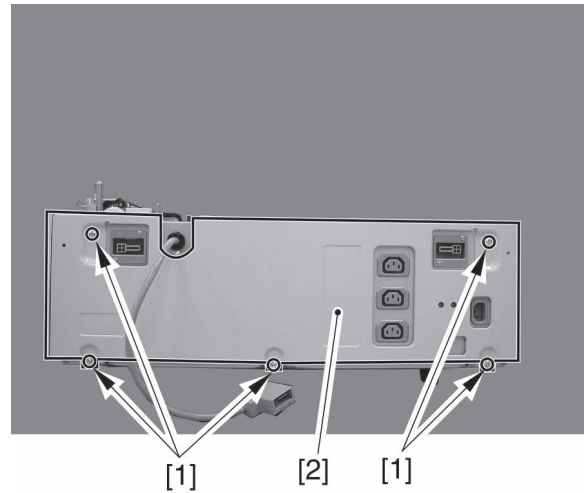

F02-404-01

- 2) Remove the 3 screws [1], disconnect the 3 connectors [2], and remove the card spacer [3]; then, detach the power supply PCB [4].

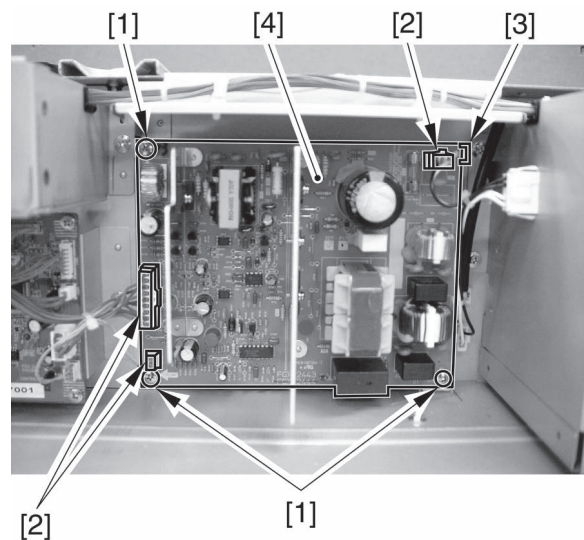

F02-404-02

4.5 Removing the Pedestal Controller PCB

- 1) Remove the pedestal rear cover.

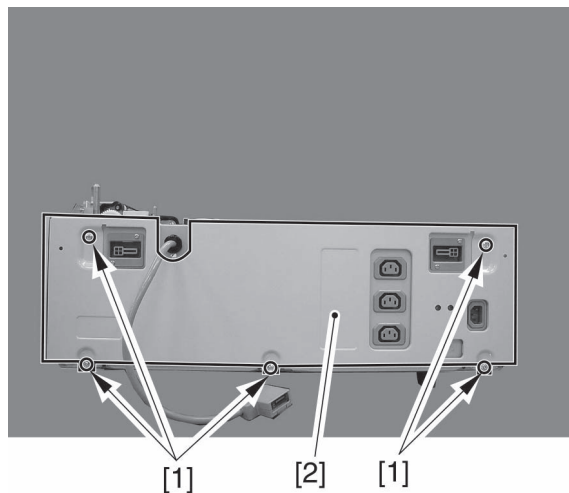

F02-405-01

- 2) Disconnect the connectors, and remove the 6 screws [1]; then, detach the pedestal controller PCB.

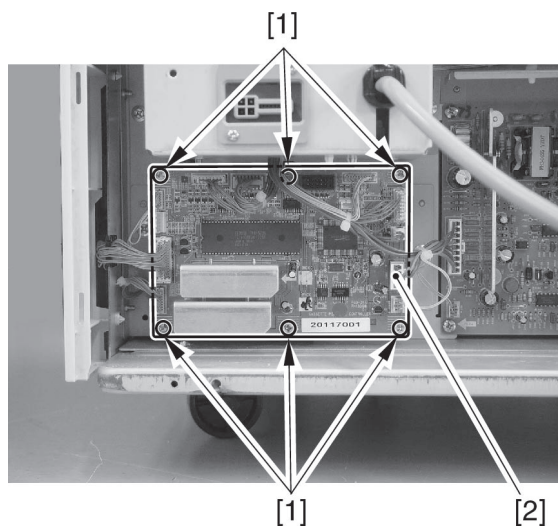

F02-405-02

4.6 Removing the Circuit Breaker



The machine uses 2 circuit breakers, and they may be removed in the same way.

- 1) Remove the pedestal rear cover.
- 2) Free the harness from the wire saddle, disconnect the 4 connectors, and remove the 4 screws [2]; then, detach the AC socket base [3].

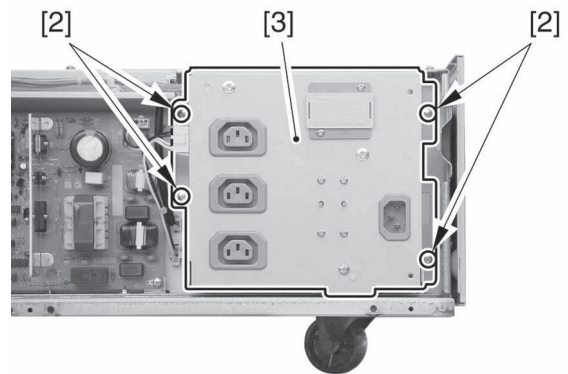
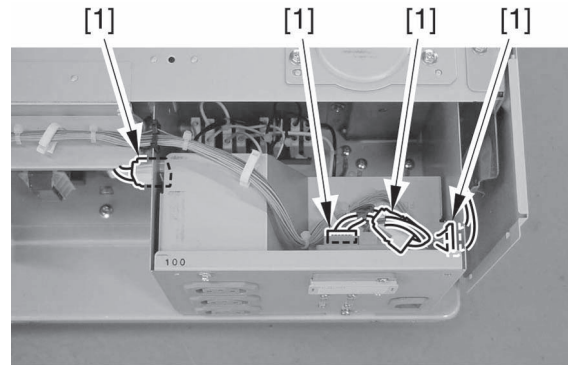

F02-406-01

- 3) Remove the 2 terminals [1], and remove the 2 screws [2]; then, detach the circuit breaker [3].

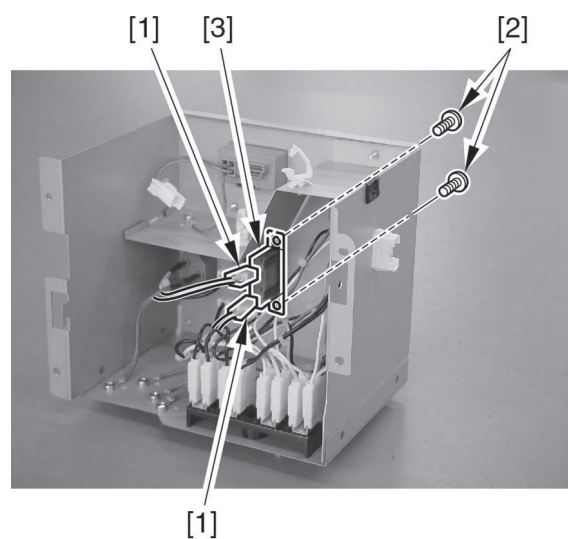

F02-406-02

4.7 Removing the Pickup Motor



The machine uses 2 pickup motors, and they may be removed in the same way.

- 1) Remove the pedestal rear cover.
- 2) Disconnect the connector of the pedestal controller PCB, and remove the 2 screws [1]; then, detach the pedestal controller PCB base [2].

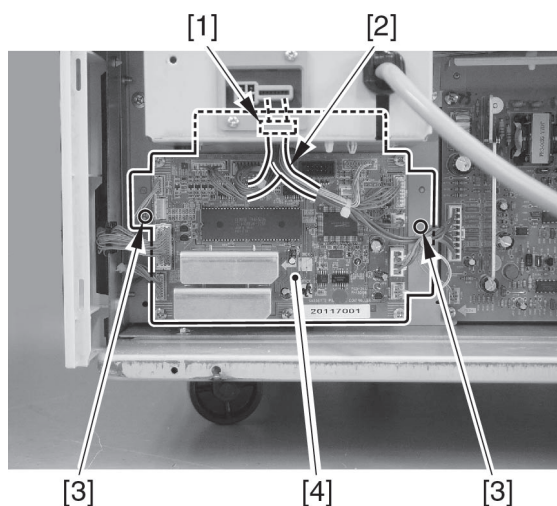

F02-407-01

- 3) Remove the 2 screws [1], and detach the lattice connector base [2].

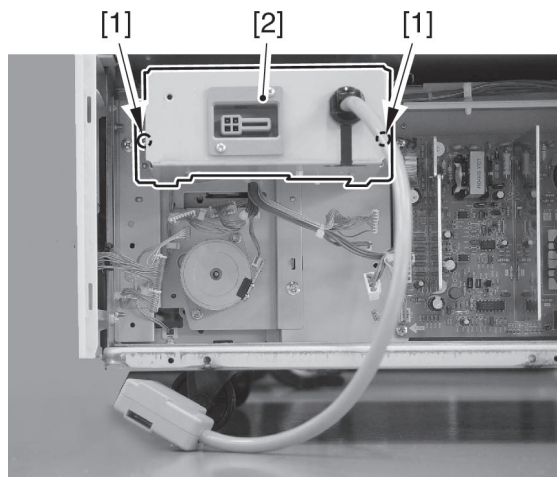

F02-407-02

- 4) Disconnect the connector [1], and remove the 2 screws [2]; then, remove the pickup motor [3].

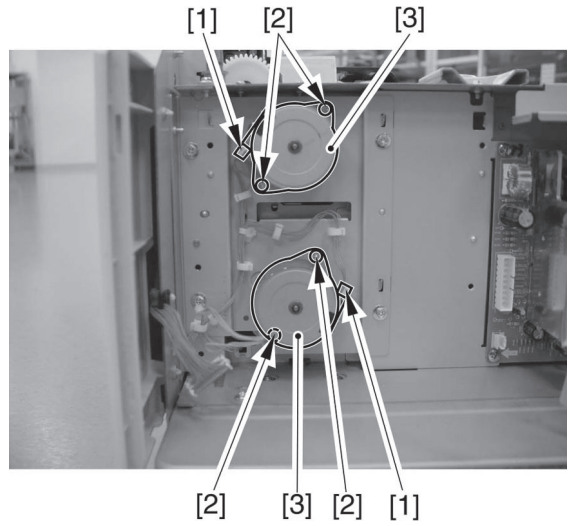

F02-407-03

4.8 Removing the Pickup Unit

- 1) Slide out the cassette.
- 2) Open the pedestal right cover, and remove the 2 screws [1]; then, detach the right front cover [2] and the right rear cover [3].

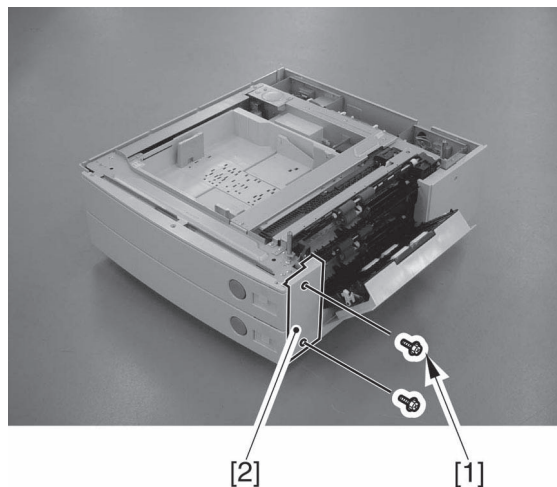

F02-408-01

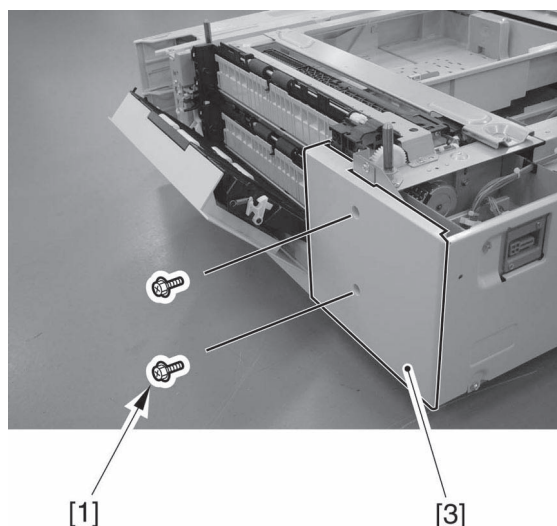

F02-408-02

- 3) Remove the screw [1], and detach the pedestal right cover [2] and the pedestal right cover [3].

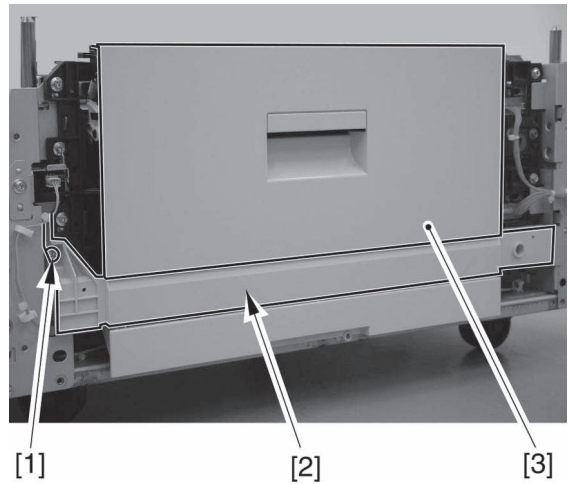

F02-408-03

- 4) Remove the screw [1], and detach the sensor mounting plate [2].

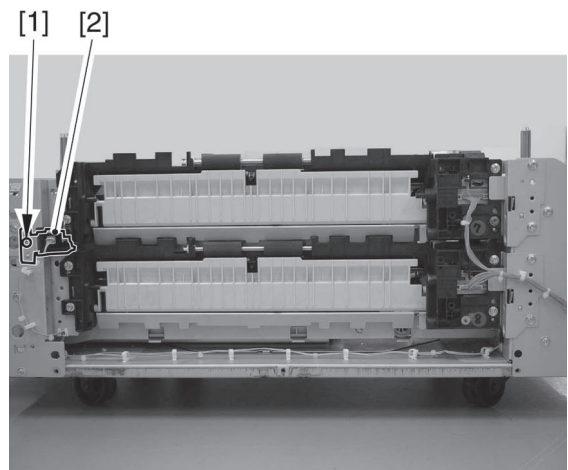

F02-408-04

- 5) Disconnect the connector [1], and remove the 4 screws [2]; then, detach the pickup unit [3].

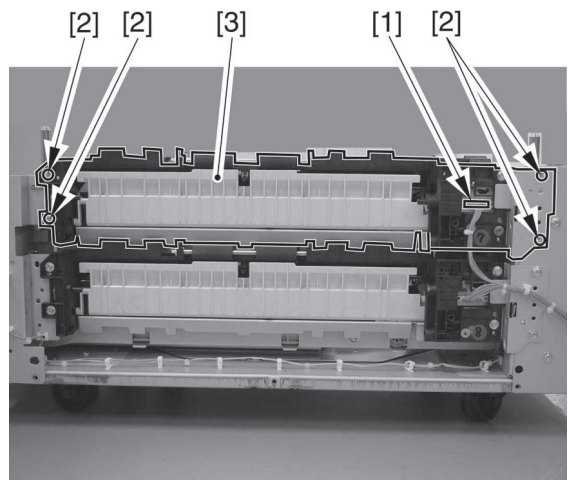

F02-408-05

CHAPTER 3

PLAIN PEDESTAL

1 Plain Pedestal-C1

1.1 Outline

Item	Specifications	Remarks
Compartment	Yes	
Power supply	Yes	Options power supply
Dimensions	620 (W) × 705 (D) × 312 (H) mm	
Weight	24 kg (approx.)	
Maximum power consumption	100 W	

T03-102-01

1.2 Construction

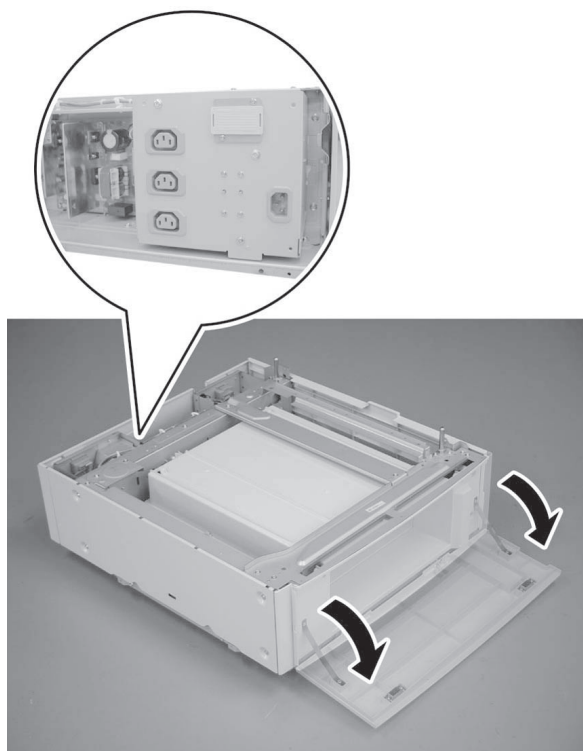

F03-102-01

1.3 Options Power Supply

See Printer Unit>Chapter 7 Externals and Controls> 4. Power Supply.

2 Disassembly/Assembly

2.1 External Cover

- [1] Left cover
- [2] Front cover
- [3] Right cover
- [4] Rear cover
- [5] Face cover

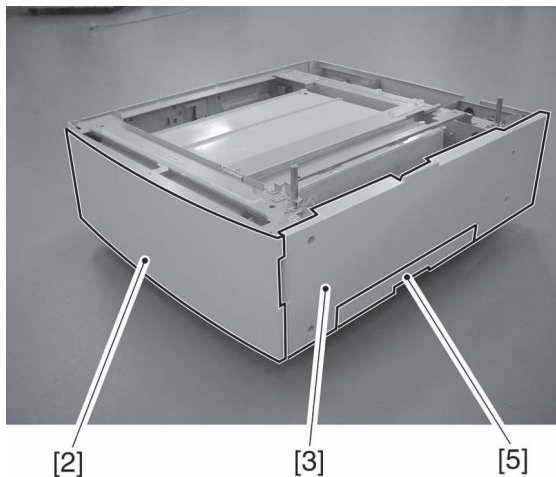

F03-201-01

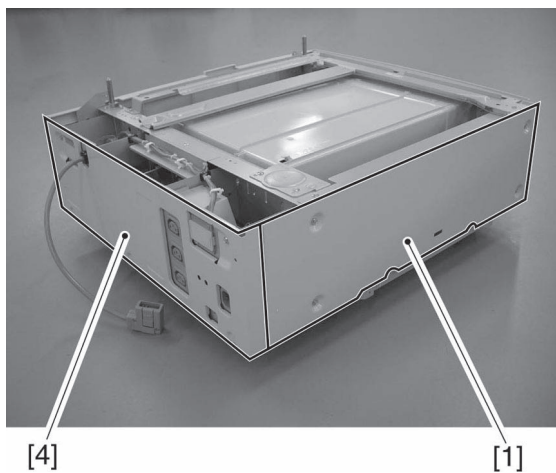

F03-201-02

2.2 Removing the Power Supply PCB

- 1) Remove the 5 screws [1], and detach the pedestal rear cover [2].

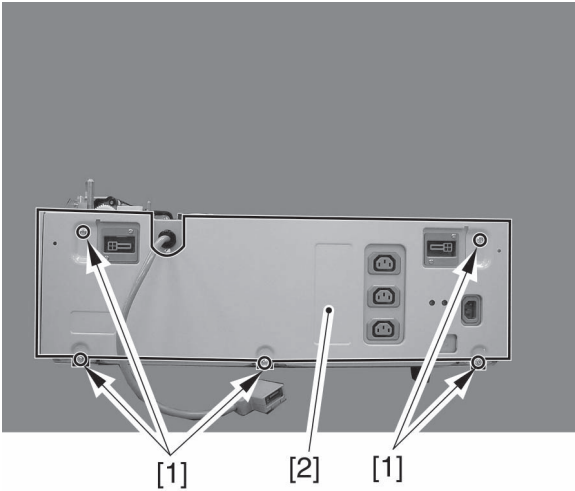

F03-202-01

- 2) Remove the 3 screws [1] and the card spacer [3]; then, detach the power supply PCB [4].

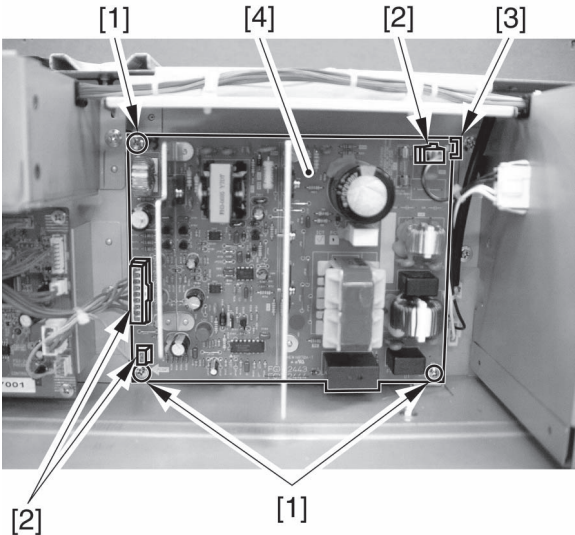

F03-202-02

2.3 Removing the Pedestal Controller PCB

- 1) Remove the pedestal rear cover.

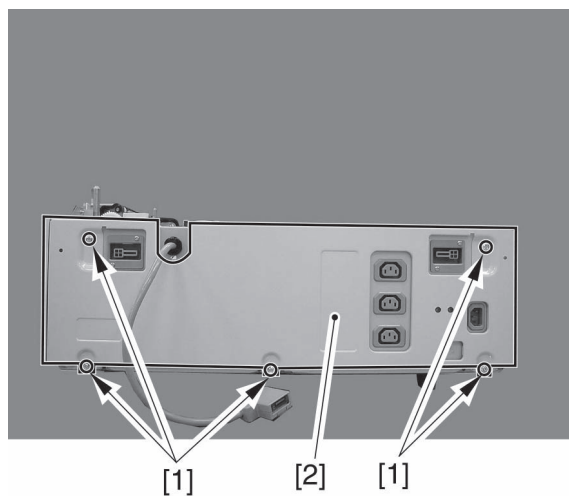

F02-203-01

- 2) Disconnect the connectors, and remove the 6 screws [1]; then, detach the pedestal controller PCB.

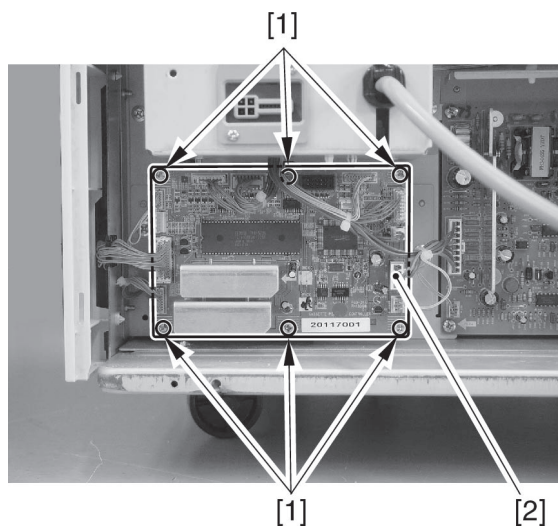

F02-203-02

2.4 Removing the Circuit Breaker

- 1) Remove the pedestal rear cover.
- 2) Free the harness from the wire saddle, disconnect the 3 connectors [1], and remove the 4 screws [2]; then, detach the AC socket base [3].

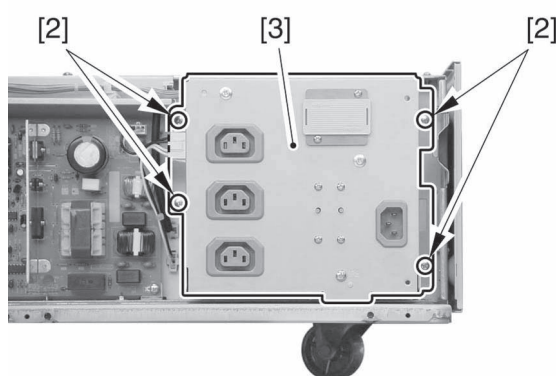
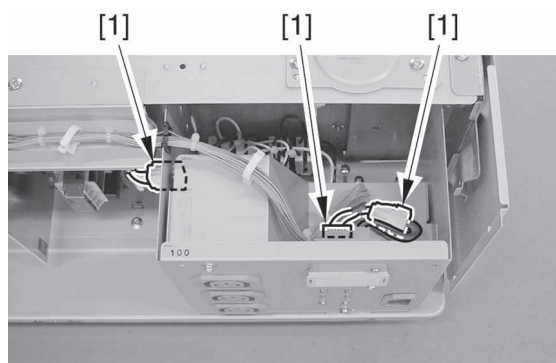

F02-204-01

- 3) Remove the 2 terminals [1] and 2 screws [2]; then, detach the circuit breaker [3].

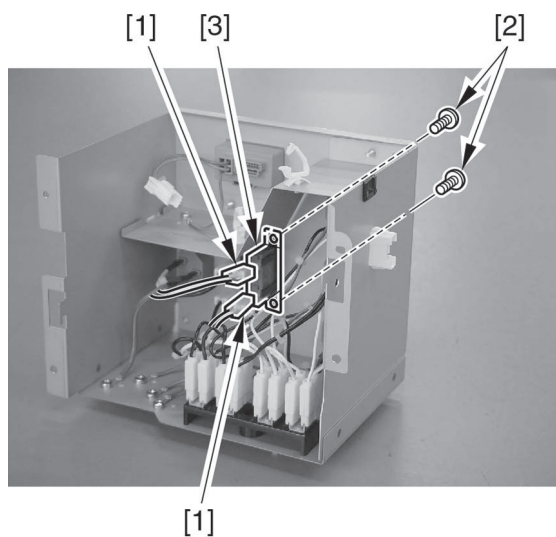

F03-204-02



The machine uses 2 circuit breakers, and they may be removed in the same way.

CHAPTER 4

CASSETTE HEATER

1 Cassette Heater Unit-24

1.1 Construction

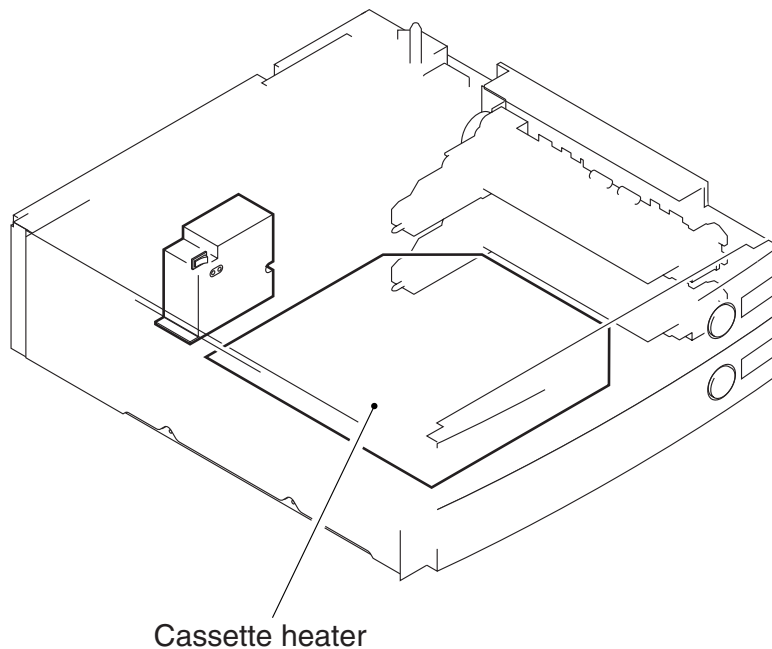

F04-101-01

1.2 Control

- The cassette heater is not supplied with power unless the cassette heater switch is turned on.

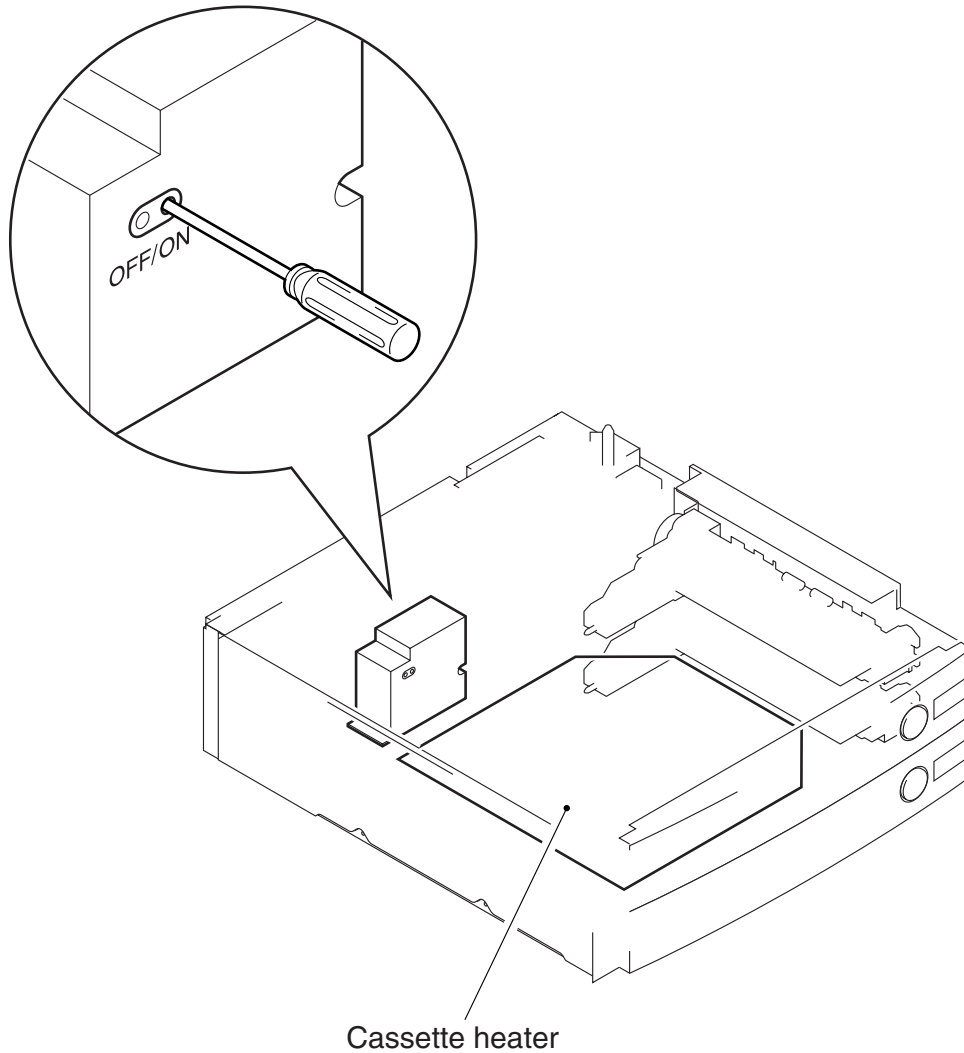

F04-102-01

Operation	Cassette 1/2 heater	Cassette 3/4 heater
Main power switch OFF	Yes	Yes
Main power switch ON	Yes	Yes
Standby, cover open/closed	Yes	Yes
Copy/print	No	No
Power save mode (-10%)	No	Yes
Power save mode (-25%)	Yes	Yes
Power save mode (-50%)	Yes	Yes
Power save mode (immediate recovery)	Yes	Yes
Low power mode	Yes	Yes
Sleep mode	Yes	Yes

Yes: heater control ON No: heater control OFF

T04-102-01

1.3 Setting the Cassette Heater Switch to ON

Be sure to turn on the cassette heater switch if paper tends to become moist.

Recommended Settings

Low-temperature environment: cassette heater switch OFF.

High-humidity environment: cassette heater switch ON.



If any of the following faults occurs, be sure that the cassette heater switch is ON:

- solid black images tend to be coarse.
- images have distortion when the machine is left alone for a long time (2 days)
- fixing/separation problem
- solid black images have traces of the pickup roller

CHAPTER 5

FAX KIT

1 Overview

In order to enable the digital fax to operate as an advanced multi-function fax, this product is equipped with a digital processing function and telephone line communication function. It has a modem that is compliant with the ITU-T recommended standard V.34 and is capable of image processing speeds of up to 33.6kbps.

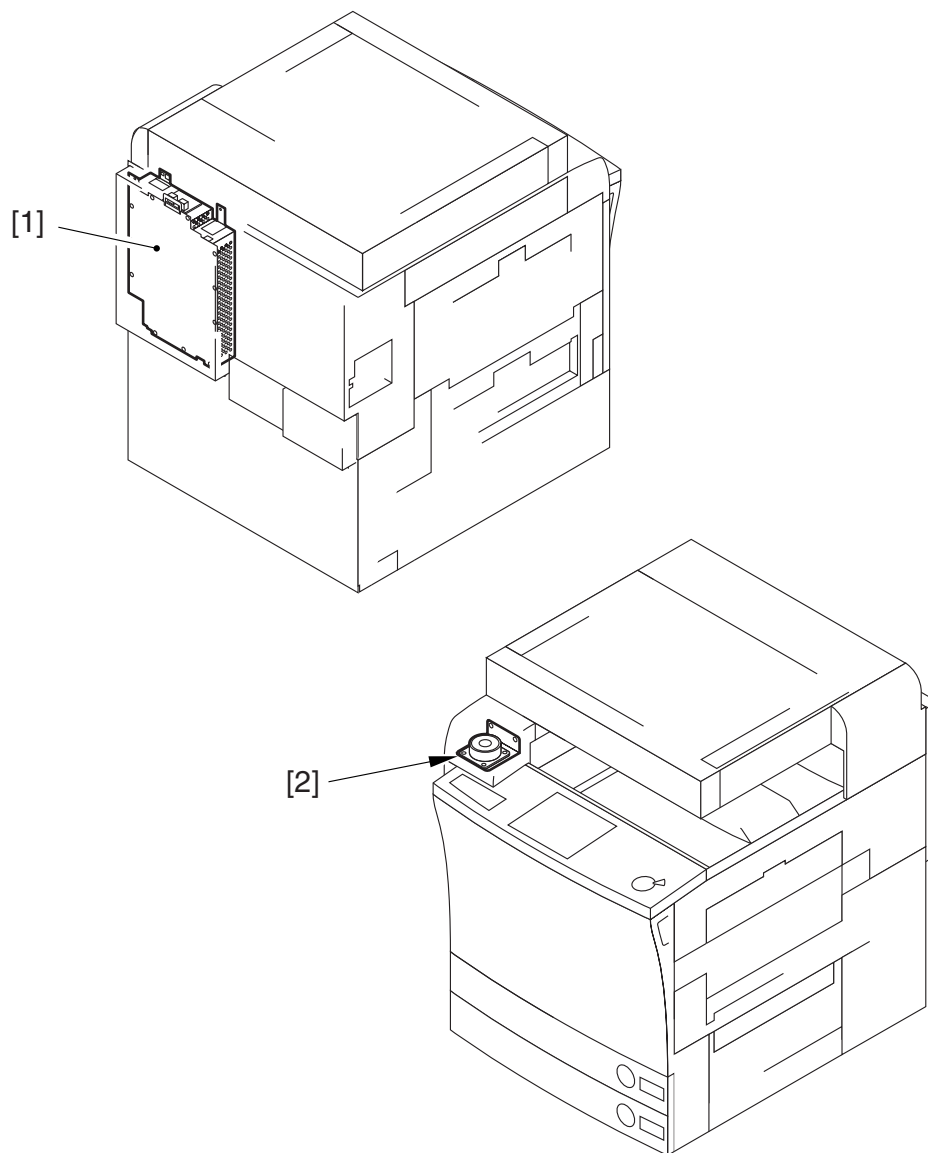

F05-100-01

- [1] Super G3 FAX Board M1
- [2] Speaker unit

This board comes in three types, designed according to voltage and area of installation, and they differ from one another for the following:

- | | 120V Area (USA) | 220V Area (EU) | 240V (AUS, Asia) |
|---|-----------------|--------------------------------|-------------------------------------|
| • NCU board | Type A | Type B | Type C |
| • Modular board | Type A (3-hole) | Type B (1-hole)
w/fuse hole | Type C (1-hole)
poly-switch type |
| • G3 FAX control board | used in common | ← | ← |
| • The modular cable has been modified to suit the standards of each country of installation | | | |

2 Specifications

Communications

G3, IFAX

Applicable lines

- Subscriber telephone line (PSTN)
- Can be connected to Class 1 or Class 2 facsimile communication terminals (16Hz and 1300Hz enabled)

Modulation system

G3 image processing signals ITU-T V.27ter (2.4Kbps, 4.8Kbps)
 ITU-T V.29 (7.2Kbps, 9.6Kbps)
 ITU-T V.17 (TC 7.2Kbps, TC9.6Kbps, 12Kbps 14.4Kbps)
 ITU-T V.34 (2.4Kbps, 4.8Kbps, 7.2Kbps, 9.6Kbps, 12Kbps,
 14.4Kbps, 16.8Kbps, 19.2Kbps, 21.6Kbps, 24Kbps, 26.4Kbps,
 28.8Kbps, 31.2Kbps, 33.6Kbps)

G3 protocol signals ITU-T V.21 No. 2 (300bps)
 ITU-T V.8, V34 (300bps, 600bps, 1200bps)

Transmission speeds

G3
 33.6Kbps, 31.2Kbps, 28.8Kbps, 26.4Kbps, 24kbps, 21.6Kbps, 19.2Kbps, 16.8Kbps,
 14.4Kbps, 12Kbps, TC9.6Kbps, TC7.2Kbps, 9.6Kbps, 7.2Kbps, 4.8Kbps, 2.4Kbps
 Equipped with automatic fall-back function.

Encoding system

G3
 JBIG, MMR, MR, MH

G3 original compression protocol

No

Modem IC

Connexant FM336

Error correction

ITU-T ECM

Scanning assembly specifications

Transmission document size

A3, A4, A4R, A5, A5R, B4, B5, B5R

LTR, LTRR, LGL, 11 × 17, STMT, STMTR

With DADF: Double-sided documents can be transmitted.

Scanning line density

G3

Standard 8 dot/mm × 3.85 lines/mm

Fine 8 dot/mm × 7.7 lines/mm

Superfine 8 dot/mm × 15.4 lines/mm

Ultrafine 16 dot/mm × 15.4 lines/mm

Halftone

T-BIC

Recording assembly specifications

Maximum reception size A3 (297 mm × 420 mm)

Scanning line density 600 × 600dpi

Memory specifications

Image memory Approx. 3,700 sheets (Canon FAX standard chart No. 1)

Memory type Hard disk (image area approx. 11.7GB)

Storage method TIFF-MMR

Other specifications

Remote telephone connection

No

FAX/TEL switching function

No

Polling function (F code)

No

Memory box function

Yes

Password reception

Yes

Forwarding function

Yes

Own telephone number notification function

Yes

User ID notification function

No

Language display switching function

Yes (Languages selectable depend on the installed language module.)

3 G3 FAX control PCB

3.1 G3 FAX control PCB element block diagram

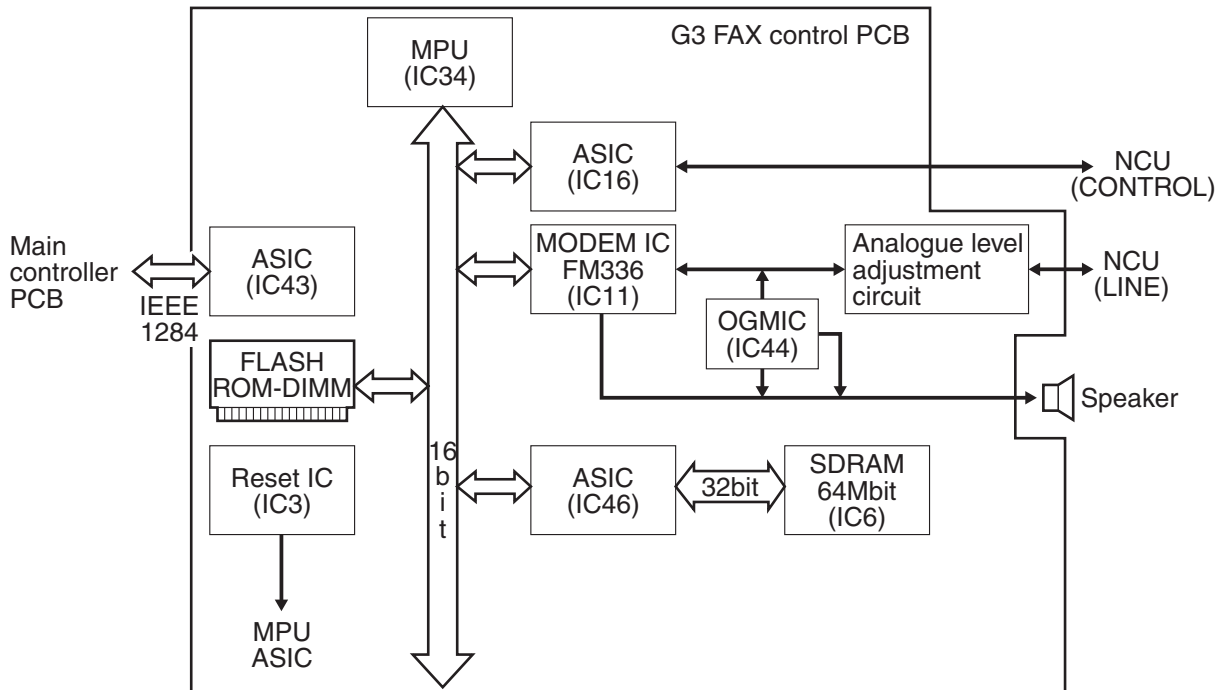

F05-301-01

3.2 G3 FAX control PCB components

MPU (IC34)

Controls communications on the line.

Equipped with a 256Kbyte internal ROM and 10Kbyte internal RAM, the IC operates at 3.3V.

ASIC (IC46)

Performs JBIG encoding and decoding and SDRAM control. The 64Mbit SDRAM is connected with a 32bit wide bus.

ASIC (IC43)

Controls IEEE 1284 bi-directional parallel communication, which is the interface with the main controller PCB, and also controls the MPU peripheral chips, off-hook detection processing and CI counter processing.

G3 FAX control DIMM slot (J11)

The 16Mbit FLASH-ROM DIMM mounted in this slot has a programme written into it that controls communication on the analogue telephone line. The DIMM can be upgraded via download with the service support tool or by physical replacement.

ASIC (IC16)

Controls ports such as OGM, NCU and the speaker, etc. ASIC (IC16) on the multi-port PCB controls the NCU port for the second line.

SDRAM (IC6)

This 64Mbit SDRAM is used for image data encoding and decoding process in transmission and reception as well as for the memory for the MPU's work area.

Reset IC (IC3)

The reset IC is used to reset the board's MPU when power is supplied or when the power supply voltage drops.

MODEM IC (IC11)

The Conexant FM336 modem modulates the transmission data from the MPU, based on ITU-T's V.17, V.21, V.27ter, V.29 and V.34, when transmitting on the line. In reception, reception data from the line are demodulated, based on ITU-T's V.17, V.21, V.27ter, V.29 and V.34.

OGMIC (IC44)

The OGMIC is used to play the outgoing message.

4 NCU PCB

4.1 NCU PCB block diagram

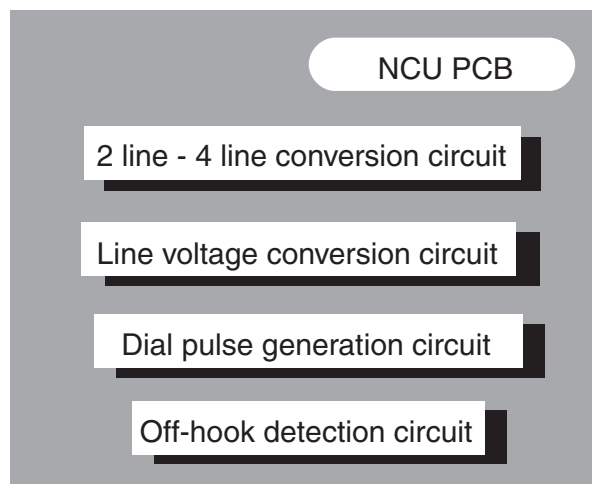

F05-401-01

4.2 NCU PCB functions

2 line - 4 line conversion circuit

Converts signals from a 2-line telephone line into 4 signal lines for transmission signals and reception signals. Also, prevents transmission signals from the modem from being rerouted to the reception circuitry.

Dial pulse generation circuit

The dial pulse generation circuit generates pulses by turning the relays in the circuit on and off in response to control signals from the G3 FAX control PCB and outputs dial signals from the fax on the dial line.

Off-hook detection circuit

This circuit detects the off-hook state by detecting the DC current that flows to the circuit when either the telephone connected to the telephone connection terminal or the option handset is off-hook.

Line voltage conversion circuit

The NCU board circuit's primary is controlled +48V DC voltage. Therefore, a condenser is used to cut the DC component so that only the audio signals are converted to model level voltage.

5 Service Mode

5.1 Overview

The service mode contains the following ten items (#1 to #10).

#1 SSSW: Service soft switches

These switches are for error management, echo countermeasures, communication problem countermeasures, etc., and registrations and settings relating to basic fax functions.

#2 MENU: Menu switch settings

Registration and settings related to functions required upon installation, such as NL equalizer, output level, etc.

#3 NUMERIC Param: Numeric parameter settings

Used to enter numeric parameters.

#4 NCU: (cannot be adjusted)

This item is automatically set according to the settings made in #5 TYPE.

#5 TYPE: Country settings

When [STANDARD] is set as displayed, #4 NC data are set to conform to Japanese domestic communication standards.

#7 PRINTER: Printer function settings

Registration and setting of basic service functions for the printer, such as conditions for reducing reception images, etc.



#8 CLEAR: Data initialization mode setting

Initialises all data to initial settings.

#9 TEST: Executes various types of tests.

#10 REPORT: Outputs reports.

5.2 Service mode operation

- 1) Press the user mode key “”.
- 2) Press numeric keys ‘2’ and ‘8’ simultaneously.
- 3) Press the user mode key “” again.

The connected options will be displayed.

(FEEDER, FAX, BOARD)

The board’s service mode can be entered by selecting FAX.

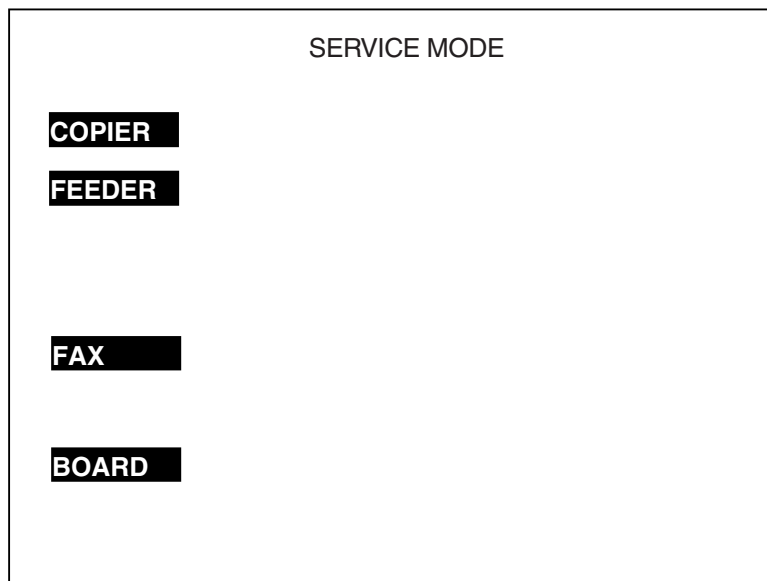

F05-502-01

COPIER: Service mode of the connected main unit

FEEDER: Service mode of the ADF (*)

FAX: Service mode of the fax (*)







BOARD: Service mode of the option board (*)

*: Only displayed when the option in question is mounted.

5.3 Meaning of keys

The display for item #1 SSSW is used here to explain the meaning of the keys. The meanings and operation of keys are common to all displays.

Sssw	Menu	Num	Ncu	Type	ISDN	Print	Clear	Test	Report
								<1/7>	<READY>
SW01	0	0	0	0	0	0	0	0	0
SW02	1	0	0	0	0	0	0	0	0
SW03	0	0	0	0	0	0	0	0	0
SW04	1	0	0	0	0	0	0	0	0
SW05	0	0	0	0	0	0	0	0	0
SW06	1	0	0	0	0	0	0	0	0
SW07	0	0	0	0	0	0	0	0	0
SW08	1	0	0	0	0	0	0	0	0

					
←	→	▽	△	↵	OK ↵
Page forward/return		Confirm entered value			

F05-503-01

- For bit switches, to change the value from 1 to 0 or from 0 to 1, press directly on the desired bit (value).
- To change a value or execute an item, press OK.
- Numeric values are entered with the numeric keys.
- To return to the previous level, use the [RESET] key.



When service mode settings have been changed, the main power supply must always be turned OFF/ON. Settings made in service mode are saved on to the main unit's hard disk. When the main power supply is ON, the settings on the main unit's hard disk become valid when loaded to the G3/G4 fax control circuit board, so when settings changes are made related to this board, the main power supply must always be turned OFF/ON.

6 Service Mode Menu List

The service mode contains the following ten items (#1 to #10).

#1 SSSW	—	SW01	Error/copy management
	—	SW02	FNet settings
	—	SW03	Echo countermeasure settings
	—	SW04	Communication problem countermeasure settings
	—	SW05	Standard function 'DIS signal' settings
	—	SW06 to SW08	Not in use
	—	SW09	Communication results display settings
	—	SW10 to SW11	Not in use
	—	SW12	Pager timer settings
	—	SW13 to SW24	Not in use
	—	SW25	Report display function settings
	—	SW26	Transmission function settings
	—	SW27	Not in use
	—	SW28	V.8/V.34 protocol settings
	—	SW29 to SW50	Not in use

#2 MENU	—	001 to 004	Not in use
	—	005	NL equalizer
	—	006	Line monitor
	—	007	Output level (ATT)
	—	008	V.34 modulation speed upper limit
	—	009	V.34 data speed upper limit
	—	010	Pseudo CI signal frequency
	—	011 to 020	Not in use

#3 NUMERIC	001	Not in use	
	002	RTN output conditions (1)	
	003	RTN output conditions (2)	
	004	RTN output conditions (3)	
	005	NCC pause time (before ID code)	
	006	NCC pause time (after ID code)	
	007	Pre-pause length upon dialling	
	008	Not in use	
	009	Comparison digits for sender's telephone number and receiver's telephone number	
	010	Line connection identification time	
	011	T.30 timer (for reception)	
	012	Not in use	
	013	T.30 EOL timer	
	014	Not in use	
	015	Hooking detection time	
	016	Time from line seizure to pseudo RBT output in FAX/TEL switching	
	017	Pseudo RBT signal pattern ON	
	018	Pseudo RBT signal pattern OFF (short)	
	019	Pseudo RBT signal pattern OFF (long)	
	020	Pseudo CI signal pattern ON	
	021	Pseudo CI signal pattern OFF (short)	
	022	Pseudo CI signal pattern OFF (long)	
	023	FAX/TEL switching CNG detection level	
	024	FAX/TEL switching pseudo RBT output level	
	025	Not in use	
	026	Not in use	
	027	V21 low speed flag preamble detection time	
028-80	Not in use		
#7 PRINTER	SSSW	SW01 to SW04	Not in use
		SW05	Reduction/cassette selection settings
		SW06	Reduction settings
		SW07 to SW20	Not in use
		NUMERIC Param.	01
		02	Not in use
		03	Not in use
		04	Leading edge margin
		05-30	Not in use

#8 CLEAR — TEL
 — USSW SW
 — SRV SW
 — NCU
 — SRV DATA
 — REPORT
 — ALL
 — COUNTER
 — ISDN

#10 CLEAR — DATA
 — DUMP

SSSW-SW01: Error/copy management

Bit	Function	1	0	Factory setting
0	Serviceman error codes	Output	Do not output	0
1	Error dump list	Output	Do not output	0
2	Not in use	—	—	
3	Not in use	—	—	
4	Not in use	—	—	
5	Not in use	—	—	
6	Not in use	—	—	
7	Not in use	—	—	

T05-700-01

[Bit 0]

Allows selection of serviceman error code output. When 'Output' is selected, the serviceman error codes are displayed on the display and in the report.

[Bit 1]

Allows selection of error dump list output. When 'Output' is selected, an error dump list is attached to the error transmission report and the reception results report upon error.

SSSW-SW02: Network connection conditions settings

Bit	Function	1	0	Factory setting
0	Not in use	—	—	
1	Not in use	—	—	
2	Not in use	—	—	
3	Not in use	—	—	
4	Not in use	—	—	
5	Not in use	—	—	
6	Not in use	—	—	
7	FNet non-ringing service	Support	Do not support	1

T05-700-02

[Bit 7]

Allows selection of whether to support the FNet (facsimile communication network) non-ringing service. If 'Support' is selected, when the FC signal (1300Hz tonal signal) is detected from the FNet, the fax is received automatically without ringing.

#1 SSSW-SW03: Echo countermeasure settings

Bit	Function	1	0	Factory setting
0	Not in use	–	–	0
1	Echo protect tone in high speed transmission	Send	Do not send	0
2	Not in use	–	–	0
3	Not in use	–	–	0
4	Transmission mode: International TX (1)	Yes	No	0
5	Transmission mode: International TX (2) or (3)	Yes	No	0
6	Transmission mode	International TX (3)	International TX (2)	0
7	Tonal signal before CED signal transmission	Send	Do not send	0

T05-700-03

[Bit 1]

Allows selection of whether to send an echo protect tone with a high speed transmission V.29 (transmission speed is 9600bps or 7200bps) modem signal.

When there are many errors, due to the line conditions, select 'Send' echo protect signal. When 'Send' is selected, an un-modulated carrier signal is sent for approximately 200ms as a synchronization signal prior to image transmission.



Error codes generated by line conditions in transmission:
 ##100, ##104, ##281, ##282, ##283, ##750, ##755, ##760, ##765

[Bit 7]

Allows selection of whether to send a 1080Hz tonal signal prior to the CED signal. If there are frequent errors arising due to an echo when receiving from overseas, select 'Send'.



Error codes caused by echo in reception:
 #005, ##101, ##106, ##107, ##114, ##200, ##201, ##790

[Bits 4, 5, 6]

Allow selection of the transmission mode: International transmission (1), International transmission (2), International transmission (3).

In the event of frequent errors due to echo when transmitting overseas, set the transmission mode by dial registration or by service soft switches.



Memo

Error codes caused by echo in transmission:

#005, ##100, ##101, ##102, ##104, ##201, ##280, ##281, ##283, ##284, ##750, ##760, ##765, ##774, ##779, ##784, ##794

Dial registration settings (user level)

Set 'International transmission (1)' when registering the address book. If the error is not cleared, try 'International transmission (2)' then 'International transmission (3)'. The transmission mode set by one touch dial registration or coded speed dial registration will have priority over the service soft switch settings.

When these switches are used to select the transmission mode, International transmission mode is set, even when using the numeric keys for transmission. For reference, the transmission mode settings are as described below.

Transmission mode	Bit							
	7	6	5	4	3	2	1	0
International transmission (1)	*	0	0	1	0	0	*	0
International transmission (2)	*	0	1	0	0	0	*	0
International transmission (3)	*	1	1	0	0	0	*	0

T05-700-04

International transmission (1): Ignores the first DIS signal when the other party is transmitting.

International transmission (2): Sends a 1850Hz tonal signal upon DIS signal transmission.

International transmission (3): Sends a 1650 tonal signal upon DIS signal transmission.

#1 SSSW-SW04: Communication trouble countermeasure settings

Bit	Function	1	0	Factory setting
0	Not in use	–	–	0
1	Not in use	–	–	0
2	Protocol signals final flag sequences	2	1	0
3	RX mode after sending CFR signal	High speed	High speed/ low speed	0
4	Length of time low speed signals are ignored after sending CFR	1500ms	700ms	0
5	Not in use	–	–	0
6	CNG in manual TX	Do not send	Send	0
7	CED in manual RX	Do not send	Send	1

T05-700-05

[Bit 2]

Allows selection of number of final flag sequences in protocol signals (transmission speed is 300bps).

When the other party cannot correctly receive the protocol signals sent by this unit, select '2'.



Error codes generated in transmission:

##100, ##280, ##281, ##750, ##753, ##754, ##755, ##758, ##759, ##760, ##763, ##764, ##765, ##768, ##769, ##770, ##773, ##775, ##778, ##780, ##783, ##785, ##788

[Bit 3]

Allows selection of reception mode after sending CFR signal.

In the event of frequent errors in reception, due to line conditions, select 'High speed' for the reception mode. At the same time, set 'ECM reception' to 'OFF' in the user mode.



Error codes caused by line conditions in reception:

##107, ##114, ##201

Before changing the setting of this bit, try changing bit 4. If errors persist, change this bit.

When 'High speed' is selected, after the CFR signal is sent, only high speed (image) signals are received.

[Bit 4]

Selects the length of time the low speed signals received after CFR signal transmission will be ignored.

If the line condition is not good and it is difficult to receive image signals, set the time to '1500ms'.

[Bit 6]

Selects whether to send CNG in manual transmission.

In the event of frequent errors where the machine does not switch to fax when a manual transmission is sent to a FAX/TEL switching programmed fax, set to 'Send'.

[Bit 7]

Selects whether to send CED in manual reception.

When the other party does not begin transmission when manual reception is initiated, set to 'Send'.

#1 SSSW-SW5: Standard function (DIS) settings

Bit	Function	1	0	Factory setting
0	Not in use	–	–	0
1	Mm/ inch conversion (Text mode)	Yes	No	0
2	Mm/ inch conversion (Text/ photo mode)	Yes	No	0
3	Bit output from DIS signal bit 33 onward	Prohibit	Allow	0
4	Length of paper declared in DIS	A4/ B4 size	Any size	0
5	Not in use	–	–	0
6	Not in use	Do not declare	Declare	0
7	Not in use	–	–	0

T05-700-06

[Bit 1]

Mm/ inch conversion in sub-scanning direction for images scanned in text mode.

[Bit 2]

When Bit 1 is 1, mm/ inch conversion is performed in the sub-scanning direction on images scanned in text/ photo mode.

[Bit 3]

Selects whether to allow output from Bit 33 onward of DIS signal.



When 'Prohibit' is selected, the superfine reception and memory box functions of other manufacturers' machines cannot be used.

[Bit 4]

Allow selection of whether the paper declared in the DIS signal is cut paper.

When receiving long length documents, in order to have the transmitting machine divide up the document, select 'A4/B4'.



Some transmitting machines cannot divide long length documents.

SSSW-SW12: Page timer settings

Bit	Function	1	0	Factory setting
0	One page time out in TX	1	0	1
1		1	0	1
2	Length of one page time out in TX	1	0	0
3	(HT transmission)	1	0	0
4	Length of one page time out in RX	1	0	0
5		1	0	0
6	Not in use			0
7	Separate page timers for TX and RX	Set	Do not set	0

T05-700-07

In this model, if transmission or reception of a single page takes longer than 32 minutes, communication will stop. To set the time-out to a longer time, refer to the following page and set as desired.

When Bit 7 is set to 'Do not set', the per page time out will be controlled by Bit 0 and Bit 1, whatever the mode.

TX/ RX time-out length

Time-out length	Bit							
	7	6	5	4	3	2	1	0
8 min	0	*	*	*	*	*	0	0
16 min	0	*	*	*	*	*	0	1
32 min	0	*	*	*	*	*	1	0
64 min	0	*	*	*	*	*	1	1

T05-700-08

TX time-out length (text mode)

Time-out length	Bit							
	7	6	5	4	3	2	1	0
8 min	1	*	*	*	*	*	0	0
16 min	1	*	*	*	*	*	0	1
32 min	1	*	*	*	*	*	1	0
64 min	1	*	*	*	*	*	1	1

T05-700-09

TX time-out length (image modes other than text mode)

Time-out length	Bit							
	7	6	5	4	3	2	1	0
8 min	1	*	*	*	0	0	*	*
16 min	1	*	*	*	0	1	*	*
32 min	1	*	*	*	1	0	*	*
64 min	1	*	*	*	1	1	*	*

T05-700-10

RX time-out length

Time-out length	Bit							
	7	6	5	4	3	2	1	0
8 min	1	*	0	0	*	*	*	*
16 min	1	*	0	1	*	*	*	*
32 min	1	*	1	0	*	*	*	*
64 min	1	*	1	1	*	*	*	*

T05-700-11

#1 SSSW-SW25: Report display function settings

Bit	Function	1	0	Factory setting
0	TX telephone number displayed in reports	Other party number	Dialled number	0
1	Not in use	—	—	0
2	Not in use	—	—	0
3	Not in use	—	—	0
4	Not in use	—	—	0
5	Not in use	—	—	0
6	Not in use	—	—	0
7	Not in use	—	—	0

T05-700-12

[Bit 0]

Selects the TX telephone number to be displayed in the report after a transmission.

Dialled number: The dialed number will be displayed in the report.

Other party number: The telephone number declared by the other party (CSO signal data) will be displayed.

#1 SSSW-SW26: Transmitting machine function settings

Bit	Function	1	0	Factory setting
0	Not in use	–	–	0
1	Not in use	–	–	0
2	Not in use	–	–	0
3	Not in use	–	–	0
4	Not in use	–	–	0
5	Not in use	–	–	1
6	Not in use	–	–	0
7	Error report output when transmission is aborted.	Do not output	Output	0

T05-700-13

[Bit 2]

Selects whether to display a prompt asking the user to confirm broadcast transmission, in order to prevent the user from making a mistake when entering addresses for batch transmission.

[Bit 7]

Selects whether to output an error report when the STOP key has been used to abort a transmission.

#1 SSSW-SW28: V.8/ V.34 protocol settings

Bit	Function	1	0	Factory setting
0	Calling side V.8 protocol	No	Yes	0
1	Called side V.8 protocol	No	Yes	0
2	Calling side V.8 rate start	No	Yes	0
3	Called side V.8 rate start	No	Yes	0
4	Fall back from V.34 receiving side	Prohibit	Permit	0
5	Fall back from V.34 transmitting side	Prohibit	Permit	0
6	Not in use	–	–	
7	Not in use	–	–	

T05-700-14

[Bit 0]

Selects whether to use V.8 protocol when dialling.

'No': Even when V.8 is received from the called side, V.8 protocol will not be used and the protocol will start from V.21.

[Bit 1]

Selects whether to use V.8 protocol when receiving.

'No': The protocol skips V.8 and starts from V.21.

[Bit 2]

Selects whether to use V.8 protocol when the ANSam signal from the called side cannot be recognised and the called side declares V.8 in the DIS signal.

'Yes': CI is returned in response to the called side's DIS signal and V.8 protocol is used.

'No': CI is not returned in response to the called side's DIS signal and V.21 protocol is used.

In manual transmission, the V.8 rate start is not used, regardless of what settings are made here.

[Bit 3]

Selects whether to declare V.8 in the DIS signal sent after the calling side cannot recognise a received ANSam signal.

'Yes': V.8 is declared in the DIS signal and the calling side performs V.8 protocol after sending CI.

'No': V.8 is not declared in the DIS signal and V.21 protocol is performed.

In manual transmission, the V.8 rate start is not used, regardless of what settings are made here.

[Bit 4]

Selects whether to prohibit fall back from the V.34 reception side.
'Prohibit': Fall back from the V.34 reception side is not performed.

[Bit 5]

Selects whether to prohibit fall back from the V.34 transmission side.
'Prohibit': Fall back from the transmission side is not performed.

8 Menu switch settings (#2 MENU)

Ssw	Menu	Num	Ncu	Type	ISDN	Print	Clear	Test	Report
					<1/3>	<READY>			
		001		xxxxx	← (yyyyy) {aaaaa to bbbbb}				
		002		xxxxx	← (yyyyy) {aaaaa to bbbbb}				
		003		xxxxx	← (yyyyy) {aaaaa to bbbbb}				
		004		xxxxx	← (yyyyy) {aaaaa to bbbbb}				
		005		xxxxx	← (yyyyy) {aaaaa to bbbbb}				
		006		xxxxx	← (yyyyy) {aaaaa to bbbbb}				
		007		xxxxx	← (yyyyy) {aaaaa to bbbbb}				
		008		xxxxx	← (yyyyy) {aaaaa to bbbbb}				
<input type="button" value="←"/> <input type="button" value="→"/> <input type="button" value="▽"/> <input type="button" value="△"/> <input type="button" value="↵"/> <input type="button" value="OK ↵"/>									

F05-800-01

No.	Function	Selectable range
005	NL equalizer	1: ON, 2: OFF
006	Telephone line monitor	From 0 to 3
007	Output level (ATT)	From 8 to 15 (e.g. 15 = -15dBm)
008	V.34 modulation speed upper limit	0: 3429, 1: 3200, 2: 3000, 3: 2800, 4: 2743, 5: 2400
009	V.34 data speed upper limit	From 0 to 13
010	Pseudo CI signal frequency	0: 50Hz, 1: 25Hz, 2: 17Hz

T05-800-01

005 NL equalizer

Selects NL equalizer ON or OFF.

In the event of frequent errors due to poor line conditions, select NL equalizer 'ON'.



Error codes generated in transmission due to poor line conditions:

##100, ##101, ##102, ##104, ##201, ##281, ##282, ##283, ##750, ##755,
##765, ##774, ##779, ##784, ##789

Error codes generated in reception due to poor line conditions:

##103, ##107, ##114, ##201, ##790, ##793

006 Telephone line monitor

Sets the telephone line monitor function.

- 0 (DIAL): Emits telephone line monitor sound from speaker from start of connection to DIS output.
- 1: Emits telephone line monitor sound from start of transmission till end of transmission.
- 2: Line 2 monitor ON (when multi-port has been added)
- 3 (OFF): Telephone line monitor sound not emitted from speaker.

007 ATT output level

Sets the output level (ATT).

In the event of frequent errors in transmission due to poor line conditions, raise the output level (close to 8).



Error codes generated in transmission due to poor line conditions:

##100, ##101, ##102, ##104, ##201, ##280, ##281, ##282, ##283, ##284,
##750, ##752, ##754, ##755, ##757, ##759, ##760, ##762, ##764, ##765,
##767, ##769, ##770, ##772, ##774, ##775, ##777, ##779, ##780, ##782,
##784, ##785, ##787, ##789

Error codes generated in reception due to poor line conditions:

##103, ##106, ##107, ##201, ##793

008 V.34 Modulation speed upper limit

Selects upper limit of modulation speed (Baud rate) in V.34 primary channel.

When 4 (2743baud) is selected, actual transmission is at 2400baud.

009 V.34 data speed upper limit

Sets the upper limit of the data speed in V.34 primary channel within the range 2.4k to 33.6kbps, at intervals of 2400bps. (0:2.4kbps to 13: 33.6kbps)

010 Pseudo CI signal frequency

Sets the pseudo CI signal frequency.

When the FAX/ TEL switching function is operating, some external telephones do not ring.

When there is no ringing tone, the pseudo CI signal frequency is changed.

9 Numeric parameter settings (#3 NUMERIC Param.)

Sssw	Menu	Num	Ncu	Type	ISDN	Print	Clear	Test	Report
						<1/10>		<READY>	
001		xxxxx			← (yyyyy) {aaaaa to bbbbb}				
002		xxxxx			← (yyyyy) {aaaaa to bbbbb}				
003		xxxxx			← (yyyyy) {aaaaa to bbbbb}				
004		xxxxx			← (yyyyy) {aaaaa to bbbbb}				
005		xxxxx			← (yyyyy) {aaaaa to bbbbb}				
006		xxxxx			← (yyyyy) {aaaaa to bbbbb}				
007		xxxxx			← (yyyyy) {aaaaa to bbbbb}				
008		xxxxx			← (yyyyy) {aaaaa to bbbbb}				
<div style="display: flex; justify-content: space-around; align-items: center;"> ← → ▽ △ ↵ OK ↵ </div>									

F05-900-01

No.	Function	Selectable range	Initial value
02	RTN output conditions (1)	1 to 99%	10
03	RTN output conditions (2)	2 to 99 times	15
04	RTN output conditions (3)	1 to 99 lines	12
05	NCC pause length (before ID code)	1 to 60 sec.	4
06	NCC pause length (after ID code)	1 to 60 sec.	4
07	Pre-pause length when dialling	0 to 9999 (\times 10ms)	0
09	No. of digits used to compare transmitter telephone number and receiver telephone number	0 to 20 digits	6
10	Line connection identification length	0 to 9999 (10ms)	5500
11	T.30 T1 timer (for RX)	0 to 9999 (10ms)	3500
13	T.30 EOL timer	500 to 3000 (10ms)	1300
15	Hooking detection length	0 to 999	120
16	Time to response in FAX/TEL switching	0 to 9	4
17	Pseudo RBT signal pattern ON length	0 to 999	100
18	Pseudo RBT signal pattern OFF length (short)	0 to 999	0
19	Pseudo RBT signal pattern OFF length (long)	0 to 999	200
20	Pseudo CI signal pattern ON length	0 to 999	100
21	Pseudo CI signal pattern OFF length (short)	0 to 999	0
22	Pseudo CI signal pattern OFF length (long)	0 to 999	200
23	CNG detection level in FAX/TEL switching	0 to 7	4
24	Pseudo RBT output level in FAX/TEL switching	10 to 20 (TYPE = STADARD)	20
27	V21 low speed flag preamble testing length	20 (*10ms)	0

T05-900-01

[No. 02, 03, 04]

Allows setting of RTN signal conditions. In the event of frequent errors in reception due to RTN signal output, raise the levels of these parameters and relax the RTN signal conditions.



Error codes generated in reception by RTN signal output:

##104, ##107, ##114, ##201

RTN signal output condition (1) is the error line proportion of the total number of lines per reception image page.

RTN signal output condition (2) is the burst error (*1) reference value (*2).

RTN signal output condition (3) is the number of errors where the burst error reference value is not met.

*1 Burst error: Transmission error continuing for several lines.

*2 Reference value: When 15 is set, 15 consecutive lines of transmission error will be considered a burst error.

When any one of these conditions is detected during image signal reception, RTN is returned after receiving the transmitter's protocol signals. By raising these parameters, the RTN signal becomes more difficult to output.

[No. 05]

Sets the length of the pause that is automatically entered between the access code and ID code when dialling via an NCC (New Common Carrier) line.

[No. 06]

Sets the length of the pause that is automatically entered between the ID code and the other party's telephone number when dialling via an NCC (New Common Carrier) line.

[No. 07]

Sets the length of time between closing the line and dialling in automatic dialling.

[No. 09]

Sets the number of TSI comparison digits (lower XX digits) used for telephone number reference.

[No.10]

Sets the length of line connection identification time. In the event of frequent transmission errors due to poor line conditions, raise this parameter.



Error codes generated by poor line conditions: ##005, ##018.

The length of the line connection identification time is from the transmission of the dial signal until the line is disconnected on the transmitting side, and from DIS signal transmission until the line is disconnected on the receiving side.

[No. 11]

Allows setting of the T1 timer in reception (length of time machine waits for a meaningful signal after sending DIS).

[No. 13:]

Extends the length of time one line can be received in order to prevent reception errors when receiving long data lines (e.g. computer fax).

[No. 15]

Allows setting of the hooking detection time.

[No. 16]

Allows setting of the time from seizing the line till pseudo RBT is sent, when the Fax/ Tel switching function is operating.

[No. 17, 18, 19]

Used to set parameters of pseudo RBT signal output when Fax/ Tel switching is operating.

[No. 20, 21, 22]

Used to set parameters of pseudo CI signal output when Fax/ Tel switching is operating.

[No. 23]

Used to set CNG detection level when Fax/ Tel switching is operating.

[No. 24]

Used to set output level of pseudo RBT signal output when Fax/ Tel switching is operating.

[No. 27]

Allows detection and judgement time to be changed when command analysis is performed due to continuous detection of V.21 low speed command preamble over a fixed length of time.

10 Type settings (#5 TYPE)

When 'STANDARD' is selected on the display, '#4 NCU' and '#6 ISDN' data are uniformly set to match Japanese communication standards.

11 Printer function settings (#7 PRINTER)

11.1 Service soft switch settings

#7 Printer-SW05 (Reduction, cassette selection settings)

Bit	Function	1	0	Factory setting
0	Prioritise LTR	Set	Do not set	0
1	Prioritise LGL	Set	Do not set	0
2	Not in use	—	—	
3	Not in use	—	—	
4	Not in use	—	—	
5	Not in use	—	—	
6	Not in use	—	—	
7	Sub-scanning direction priority printing	Set	Do not set	1

T05-1101-01

[Bit 0, 1]

Selects whether to prioritise LEGAL sized paper for printing when receiving an image that can be printed out in 100% magnification with the same split number on either A4, LETTER or LEGAL sized paper.

Bit 1	Bit 0	Prioritisation order
0	0	A4 → LTR → LGL
0	1	LTR → A4 → LGL
1	0	LGL → LTR → A4
1	1	LTR → LGL → A4

T05-1101-02

Note that, when sub-scanning printing is prioritised, the order of prioritisation will be LTR → A4 → LGL, regardless of whether Bits 1 and 0 are set to 0.

[Bit 7]

Selects whether to set sub-scanning direction priority printing.

'Set': When B4 and A4 sized paper are in the cassettes, if an A4 long length* image is received, printing will be in B4.

'Do not set': With B5 long and A4 sized paper in the cassettes, if a B4 image is received, the image is split and printed out on B5 long.

* An image whose length is shorter than B4, but cannot be reduced to print out on A4.

#7 Printer-SW06 (Reduction settings)

Bit	Function	1	0	Factory setting
0	Not in use	—	—	
1	Not in use	—	—	
2	Not in use	—	—	
3	Not in use	—	—	
4	Not in use	—	—	
5	Reduction printing from A4 to B5	Permit	Prohibit	0
6	Not in use	—	—	
7	Not in use	—	—	

T05-1101-03

[Bit 5]

Used to reduce A4 reception documents forcibly to B5.

This function does not work when reports are being output.

11.2 NUMERIC Param. (Numeric parameter settings)

Sssw	Menu	Num	Ncu	Type	ISDN	Print	Clear	Test	Report
	<NUM>					<1/4>		<READY>	
	001			XXXXX	←	(yyyyy)	{aaaaa to bbbbb}		
	002			XXXXX	←	(yyyyy)	{aaaaa to bbbbb}		
	003			XXXXX	←	(yyyyy)	{aaaaa to bbbbb}		
	004			XXXXX	←	(yyyyy)	{aaaaa to bbbbb}		
	005			XXXXX	←	(yyyyy)	{aaaaa to bbbbb}		
	006			XXXXX	←	(yyyyy)	{aaaaa to bbbbb}		
	007			XXXXX	←	(yyyyy)	{aaaaa to bbbbb}		
	008			XXXXX	←	(yyyyy)	{aaaaa to bbbbb}		

← → ▽ △ ↵ OK ↵

F05-1102-01

No.	Function	Selectable range	Initial value	Unit
01	Permissible range of image loss when printing out a long length reception image.	0 to 9999	12	1mm
04	Leading edge margin	0 to 9999	3	1mm

T05-1102-01

[No. 1]

Sets the permissible range of image loss when printing out a long length reception image. When receiving an image whose length exceeds the valid printing length, but whose trailing edge must not be lost, lower this parameter to reduce the permissible range of image loss.

[No. 4]

Sets the leading edge margin of the valid printing length.

12 Initializing settings (#8 CLEAR)

Selecting the following items allows their settings to be cleared to the initial settings. The items, parameters and values, etc., are all cleared to the factory settings.

Item	Initialized data
TEL	Telephone number registration data
USER SW	User data and contents of SSSW#1 to #3 User data memory management contents are not cleared. Image data stored in memory are not cleared.
SERVICE SW	User data and contents of SSSW#1 to #3, #7
NCU	Contents of SSSW#4
ISDN	Contents of SSSW#6
SERVICE DATA	Contents of system dump list
REPORT	Contents of activity management reports
ALL	All settings and registration data, with the exception of #5 TYPE
COUNTER	No. of printed pages, No. of scanned pages

T05-1200-01

12.1 SSSW Default Setting

The default Setting value of each country is shown below.

TYPE	USA	EUROPE	U.K	SWEDEN	SWISS	AUSTRIA
#1 SSSW						
SW01	00000000	00010000	00010000	00010000	00010000	00010000
SW02	00000000	00000000	00000000	00000000	00000000	00000000
SW03	00000000	00000000	00000000	00000000	00000000	00000000
SW04	10000000	00000000	00000000	00000000	00000000	00000000
SW05	00000000	00000000	00000000	00000000	00000000	00000000
SW06	10000000	10000000	10000000	10000000	10000000	10000000
SW07	00000000	00000000	00000000	00000000	00000000	00000000
SW08	00000000	00000000	00000000	00000000	00000000	00000000
SW09	00000000	00000000	00000000	00000000	00000000	00000000
SW10	00000000	00000000	00000000	00000000	00000000	00000000
SW11	00000000	00000000	00000000	00000000	00000000	00000000
SW12	00000011	00000011	00000011	00000011	00000011	00000011
SW13	00000000	00000000	00000000	00000000	00000000	00000000
SW14	00000000	00000000	00000000	00000000	00000000	00000000
SW15	00000000	00000000	00000000	00000000	00000000	00000000
SW16	00000000	00000000	00000000	00000000	00000000	00000000
SW17	00000000	00000000	00000000	00000000	00000000	00000000
SW18	00000000	00000000	00000000	00000000	00000000	00000000
SW19	00011000	00000000	00000000	00000000	00000000	00000000
SW20	00000000	00000000	00000000	00000000	00000000	00000000
SW21	00000000	00000000	00000000	00000000	00000000	00000000
SW22	00000000	00000000	00000000	00000000	00000000	00000000
SW23	00000000	00000000	00000000	00000000	00000000	00000000
SW24	00000000	00000000	00000000	00000000	00000000	00000000
SW25	00000000	00000000	00000000	00000000	00000000	00000000
SW26	00100000	00100000	00100000	00100000	00100000	00100000
SW27	00000000	00000000	00000000	00000000	00000000	00000000
SW28	00000000	00000000	00000000	00000000	00000000	00000000
SW29	00000000	00000000	00000000	00000000	00000000	00000000
SW30	00000000	00000000	00000000	00000000	00000000	00000000

T05-1201-01

CHAPTER 5 FAX KIT

TYPE	DENMARK	NORWAY	HOLAND	BELGIUM	AUSTRALIA	FINLAND
#1 SSSW						
SW01	00010000	00010000	00010000	00010000	00010000	00010000
SW02	00000000	00000000	00000000	00000000	00000000	00000000
SW03	00000000	00000000	00000000	00000000	00000000	00000000
SW04	00000000	00000000	00000000	00000000	00000000	00000000
SW05	00000000	00000000	00000000	00000000	00000000	00000000
SW06	10000000	10000000	10000000	10000000	10000000	10000000
SW07	00000000	00000000	00000000	00000000	00000000	00000000
SW08	00000000	00000000	00000000	00000000	00000000	00000000
SW09	00000000	00000000	00000000	00000000	00000000	00000000
SW10	00000000	00000000	00000000	00000000	00000000	00000000
SW11	00000000	00000000	00000000	00000000	00000000	00000000
SW12	00000011	00000011	00000011	00000011	00000011	00000011
SW13	00000000	00000000	00000000	00000000	00000000	00000000
SW14	00000000	00000000	00000000	00000000	00000000	00000000
SW15	00000000	00000000	00000000	00000000	00000000	00000000
SW16	00000000	00000000	00000000	00000000	00000000	00000000
SW17	00000000	00000000	00000000	00000000	00000000	00000000
SW18	00000000	00000000	00000000	00000000	00000000	00000000
SW19	00000000	00000000	00000000	00000000	00000000	00000000
SW20	00000000	00000000	00000000	00000000	00000000	00000000
SW21	00000000	00000000	00000000	00000000	00000000	00000000
SW22	00000000	00000000	00000000	00000000	00000000	00000000
SW23	00000000	00000000	00000000	00000000	00000000	00000000
SW24	00000000	00000000	00000000	00000000	00000000	00000000
SW25	00000000	00000000	00000000	00000000	00000000	00000000
SW26	00100000	00100000	00100000	00100000	00100000	00100000
SW27	00000000	00000000	00000000	00000000	00000000	00000000
SW28	00000000	00000000	00000000	00000000	00000000	00000000
SW29	00000000	00000000	00000000	00000000	00000000	00000000
SW30	00000000	00000000	00000000	00000000	00000000	00000000

T05-1201-02

TYPE	N.Z.	ITALY	SPAIN	PORTUGAL	IRELAND	HONG KONG
#1 SSSW						
SW01	00010000	00010000	00010000	00010000	00010000	00010000
SW02	00000000	00000000	00000000	00000000	00000000	00000000
SW03	00000000	00000000	00000000	00000000	00000000	00000000
SW04	00000010	00000000	00000000	00000000	00000000	00000000
SW05	00000000	00000000	00000000	00000000	00000000	00000000
SW06	10000000	10000000	10000000	10000000	10000000	10000000
SW07	00000000	00000000	00000000	00000000	00000000	00000000
SW08	00000000	00000000	00000000	00000000	00000000	00000000
SW09	00000000	00000000	00000000	00000000	00000000	00000000
SW10	00000000	00000000	00000000	00000000	00000000	00000000
SW11	00000000	00000000	00000000	00000000	00000000	00000000
SW12	00000011	00000011	00000011	00000011	00000011	00000011
SW13	00000000	00000000	00000000	00000000	00000000	00000000
SW14	00000000	00000000	00000000	00000000	00000000	00000000
SW15	00000000	00000000	00000000	00000000	00000000	00000000
SW16	00000000	00000000	00000000	00000000	00000000	00000000
SW17	00000000	00000000	00000000	00000000	00000000	00000000
SW18	00000000	00000000	00000000	00000000	00000000	00000000
SW19	00000000	00000000	00000000	00000000	00000000	00000000
SW20	00000000	00000000	00000000	00000000	00000000	00000000
SW21	00000000	00000000	00000000	00000000	00000000	00000000
SW22	00000000	00000000	00000000	00000000	00000000	00000000
SW23	00000000	00000000	00000000	00000000	00000000	00000000
SW24	00000000	00000000	00000000	00000000	00000000	00000000
SW25	00000000	00000000	00000000	00000000	00000000	00000000
SW26	00100000	00100000	00100000	00100000	00100000	00100000
SW27	00000000	00000000	00000000	00000000	00000000	00000000
SW28	00000000	00000000	00000000	00000000	00000000	00000000
SW29	00000000	00000000	00000000	00000000	00000000	00000000
SW30	00000000	00000000	00000000	00000000	00000000	00000000

T05-1201-03

CHAPTER 5 FAX KIT

TYPE	MALASIA	HUNGARY	SAF	KOREA	CHINA	GERMAN
#1 SSSW						
SW01	00010000	00010000	00010000	00010000	00010000	00010000
SW02	00000000	00000000	00000000	00000000	00000000	00000000
SW03	00000000	00000000	00000000	00000000	00000000	00000000
SW04	00000000	00000000	00000000	00000000	00000000	00000000
SW05	00000000	00000000	00000000	00000000	00000000	00000000
SW06	10000000	10000000	10000000	10000000	10000000	10000000
SW07	00000000	00000000	00000000	00000000	00000000	00000000
SW08	00000000	00000000	00000000	00000000	00000000	00000000
SW09	00000000	00000000	00000000	00000000	00000000	00000000
SW10	00000000	00000000	00000000	00000000	00000000	00000000
SW11	00000000	00000000	00000000	00000000	00000000	00000000
SW12	00000011	00000011	00000011	00000011	00000011	00000011
SW13	00000000	00000000	00000000	00000000	00000000	00000000
SW14	00000000	00000000	00000000	00000000	00000000	00000000
SW15	00000000	00000000	00000000	00000000	00000000	00000000
SW16	00000000	00000000	00000000	00000000	00000000	00000000
SW17	00000000	00000000	00000000	00000000	00000000	00000000
SW18	00000000	00000000	00000000	00000000	00000000	00000000
SW19	00000000	00000000	00000000	00000000	00000000	00000000
SW20	00000000	00000000	00000000	00000000	00000000	00000000
SW21	00000000	00000000	00000000	00000000	00000000	00000000
SW22	00000000	00000000	00000000	00000000	00000000	00000000
SW23	00000000	00000000	00000000	00000000	00000000	00000000
SW24	00000000	00000000	00000000	00000000	00000000	00000000
SW25	00000000	00000001	00000000	00000000	00000000	00000101
SW26	00100000	00100000	00100000	00100000	00100000	00100000
SW27	00000000	00000000	00000000	00000000	00000000	00000000
SW28	00000000	00000000	00000000	00000000	00000000	00000000
SW29	00000000	00000000	00000000	00000000	00000000	00000000
SW30	00000000	00000000	00000000	00000000	00000000	00000000

T05-1201-04

TYPE	FRANCE	SINGAPORE	CZECH	SLOVENIA	CANADA	RESERVE 1
#1 SSSW						
SW01	00010000	00010000	00010000	00010000	00000000	00010000
SW02	00000000	00000000	00000000	00000000	00000000	00000000
SW03	00000000	00000000	00000000	00000000	00000000	00000000
SW04	00000000	00000000	00000000	00000000	10000000	00000000
SW05	00000000	00000000	00000000	00000000	00000000	00000000
SW06	10000000	10000000	10000000	10000000	10000000	10000000
SW07	00000000	00000000	00000000	00000000	00000000	00000000
SW08	00000000	00000000	00000000	00000000	00000000	00000000
SW09	00000000	00000000	00000000	00000000	00000000	00000000
SW10	00000000	00000000	00000000	00000000	00000000	00000000
SW11	00000000	00000000	00000000	00000000	00000000	00000000
SW12	00000011	00000011	00000011	00000011	00000011	00000011
SW13	00000000	00000000	00000000	00000000	00000000	00000000
SW14	00000000	00000000	00000000	00000000	00000000	00000000
SW15	00000000	00000000	00000000	00000000	00000000	00000000
SW16	00000000	00000000	00000000	00000000	00000000	00000000
SW17	00000000	00000000	00000000	00000000	00000000	00000000
SW18	00000000	00000000	00000000	00000000	00000000	00000000
SW19	00000000	00000000	00000000	00000000	00011000	00000000
SW20	00000000	00000000	00000000	00000000	00000000	00000000
SW21	00000000	00000000	00000000	00000000	00000000	00000000
SW22	00000000	00000000	00000000	00000000	00000000	00000000
SW23	00000000	00000000	00000000	00000000	00000000	00000000
SW24	00000000	00000000	00000000	00000000	00000000	00000000
SW25	00000000	00000000	00000000	00000000	00000000	00000000
SW26	00100000	00100000	00100000	00100000	00100000	00100000
SW27	00000000	00000000	00000000	00000000	00000000	00000000
SW28	00000000	00000000	00000000	00000000	00000000	00000000
SW29	00000000	00000000	00000000	00000000	00000000	00000000
SW30	00000000	00000000	00000000	00000000	00000000	00000000

T05-1201-05

CHAPTER 5 FAX KIT

TYPE	RESERVE 2	ASIA	POLAND	EUROPE 2	TAIWAN
#1 SSSW					
SW01	00010000	00010000	00010000	00010000	00000000
SW02	00000000	00000000	00000000	00000000	00000000
SW03	00000000	00000000	00000000	00000000	00000000
SW04	00000000	00000000	00000000	00000000	10000000
SW05	00000000	00000000	00000000	00000000	00000000
SW06	10000000	10000000	10000000	10000000	10000000
SW07	00000000	00000000	00000000	00000000	00000000
SW08	00000000	00000000	00000000	00000000	00000000
SW09	00000000	00000000	00000000	00000000	00000000
SW10	00000000	00000000	00000000	00000000	00000000
SW11	00000000	00000000	00000000	00000000	00000000
SW12	00000011	00000011	00000011	00000011	00000011
SW13	00000000	00000000	00000000	00000000	00000000
SW14	00000000	00000000	00000000	00000000	00000000
SW15	00000000	00000000	00000000	00000000	00000000
SW16	00000000	00000000	00000000	00000000	00000000
SW17	00000000	00000000	00000000	00000000	00000000
SW18	00000000	00000000	00000000	00000000	00000000
SW19	00000000	00000000	00000000	00000000	00000000
SW20	00000000	00000000	00000000	00000000	00000000
SW21	00000000	00000000	00000000	00000000	00000000
SW22	00000000	00000000	00000000	00000000	00000000
SW23	00000000	00000000	00000000	00000000	00000000
SW24	00000000	00000000	00000000	00000000	00000000
SW25	00000000	00000000	00000000	00000000	00000000
SW26	00100000	00100000	00100000	00100000	00100000
SW27	00000000	00000000	00000000	00000000	00000000
SW28	00000000	00000000	00000000	00000000	00000000
SW29	00000000	00000000	00000000	00000000	00000000
SW30	00000000	00000000	00000000	00000000	00000000

T05-1201-06

TYPE	USA	EUROPE	U.K	SWEDEN	SWISS	AUSTRIA
SW31	00000000	00000000	00000000	00000000	00000000	00000000
SW32	00000000	00000000	00000000	00000000	00000000	00000000
SW33	00000000	00000000	00000000	00000000	00000000	00000000
SW34	00000000	00000000	00000000	00000000	00000000	00000000
SW35	00000000	00000000	00000000	00000000	00000000	00000000
SW36	00000000	00000000	00000000	00000000	00000000	00000000
SW37	00000000	00000000	00000000	00000000	00000000	00000000
SW38	00000000	00000000	00000000	00000000	00000000	00000000
SW39	00000000	00000000	00000000	00000000	00000000	00000000
SW40	00000000	00000000	00000000	00000000	00000000	00000000
SW41	00000000	00000000	00000000	00000000	00000000	00000000
SW42	00000000	00000000	00000000	00000000	00000000	00000000
SW43	00000000	00000000	00000000	00000000	00000000	00000000
SW44	00000000	00000000	00000000	00000000	00000000	00000000
SW45	00000000	00000000	00000000	00000000	00000000	00000000
SW46	00000000	00000000	00000000	00000000	00000000	00000000
SW47	00000000	00000000	00000000	00000000	00000000	00000000
SW48	00000000	00000000	00000000	00000000	00000000	00000000
SW49	00000000	00000000	00000000	00000000	00000000	00000000
SW50	00000000	00000000	00000000	00000000	00000000	00000000
#2 MENU						
05	OFF	OFF	OFF	OFF	OFF	OFF
06	DIAL	DIAL	DIAL	DIAL	DIAL	DIAL
07	10	10	10	10	10	10
08	3429baud	3429baud	3429baud	3429baud	3429baud	3429baud
09	33600bps	33600bps	33600bps	33600bps	33600bps	33600bps
10	25Hz	25Hz	25Hz	25Hz	25Hz	25Hz

T05-1201-07

CHAPTER 5 FAX KIT

TYPE	DENMARK	NORWAY	HOLAND	BELGIUM	AUSTRALIA	FINLAND
SW31	00000000	00000000	00000000	00000000	00000000	00000000
SW32	00000000	00000000	00000000	00000000	00000000	00000000
SW33	00000000	00000000	00000000	00000000	00000000	00000000
SW34	00000000	00000000	00000000	00000000	00000000	00000000
SW35	00000000	00000000	00000000	00000000	00000000	00000000
SW36	00000000	00000000	00000000	00000000	00000000	00000000
SW37	00000000	00000000	00000000	00000000	00000000	00000000
SW38	00000000	00000000	00000000	00000000	00000000	00000000
SW39	00000000	00000000	00000000	00000000	00000000	00000000
SW40	00000000	00000000	00000000	00000000	00000000	00000000
SW41	00000000	00000000	00000000	00000000	00000000	00000000
SW42	00000000	00000000	00000000	00000000	00000000	00000000
SW43	00000000	00000000	00000000	00000000	00000000	00000000
SW44	00000000	00000000	00000000	00000000	00000000	00000000
SW45	00000000	00000000	00000000	00000000	00000000	00000000
SW46	00000000	00000000	00000000	00000000	00000000	00000000
SW47	00000000	00000000	00000000	00000000	00000000	00000000
SW48	00000000	00000000	00000000	00000000	00000000	00000000
SW49	00000000	00000000	00000000	00000000	00000000	00000000
SW50	00000000	00000000	00000000	00000000	00000000	00000000
#2 MENU						
05	OFF	OFF	OFF	OFF	OFF	OFF
06	DIAL	DIAL	DIAL	DIAL	DIAL	DIAL
07	10	10	10	10	10	10
08	3429baud	3429baud	3429baud	3429baud	3429baud	3429baud
09	33600bps	33600bps	33600bps	33600bps	33600bps	33600bps
10	25Hz	25Hz	25Hz	25Hz	25Hz	25Hz

T05-1201-08

TYPE	N.Z.	ITALY	SPAIN	PORTUGAL	IRELAND	HONG KONG
SW31	00000000	00000000	00000000	00000000	00000000	00000000
SW32	00000000	00000000	00000000	00000000	00000000	00000000
SW33	00000000	00000000	00000000	00000000	00000000	00000000
SW34	00000000	00000000	00000000	00000000	00000000	00000000
SW35	00000000	00000000	00000000	00000000	00000000	00000000
SW36	00000000	00000000	00000000	00000000	00000000	00000000
SW37	00000000	00000000	00000000	00000000	00000000	00000000
SW38	00000000	00000000	00000000	00000000	00000000	00000000
SW39	00000000	00000000	00000000	00000000	00000000	00000000
SW40	00000000	00000000	00000000	00000000	00000000	00000000
SW41	00000000	00000000	00000000	00000000	00000000	00000000
SW42	00000000	00000000	00000000	00000000	00000000	00000000
SW43	00000000	00000000	00000000	00000000	00000000	00000000
SW44	00000000	00000000	00000000	00000000	00000000	00000000
SW45	00000000	00000000	00000000	00000000	00000000	00000000
SW46	00000000	00000000	00000000	00000000	00000000	00000000
SW47	00000000	00000000	00000000	00000000	00000000	00000000
SW48	00000000	00000000	00000000	00000000	00000000	00000000
SW49	00000000	00000000	00000000	00000000	00000000	00000000
SW50	00000000	00000000	00000000	00000000	00000000	00000000
#2 MENU						
05	OFF	OFF	OFF	OFF	OFF	OFF
06	DIAL	DIAL	DIAL	DIAL	DIAL	DIAL
07	10	10	10	10	10	10
08	3429baud	3429baud	3429baud	3429baud	3429baud	3429baud
09	33600bps	33600bps	33600bps	33600bps	33600bps	33600bps
10	25Hz	25Hz	25Hz	25Hz	25Hz	25Hz

T05-1201-09

CHAPTER 5 FAX KIT

TYPE	MALASIA	HUNGARY	SAF	KOREA	CHINA	GERMAN
SW31	00000000	00000000	00000000	00000000	00000000	00000000
SW32	00000000	00000000	00000000	00000000	00000000	00000000
SW33	00000000	00000000	00000000	00000000	00000000	00000000
SW34	00000000	00000000	00000000	00000000	00000000	00000000
SW35	00000000	00000000	00000000	00000000	00000000	00000000
SW36	00000000	00000000	00000000	00000000	00000000	00000000
SW37	00000000	00000000	00000000	00000000	00000000	00000000
SW38	00000000	00000000	00000000	00000000	00000000	00000000
SW39	00000000	00000000	00000000	00000000	00000000	00000000
SW40	00000000	00000000	00000000	00000000	00000000	00000000
SW41	00000000	00000000	00000000	00000000	00000000	00000000
SW42	00000000	00000000	00000000	00000000	00000000	00000000
SW43	00000000	00000000	00000000	00000000	00000000	00000000
SW44	00000000	00000000	00000000	00000000	00000000	00000000
SW45	00000000	00000000	00000000	00000000	00000000	00000000
SW46	00000000	00000000	00000000	00000000	00000000	00000000
SW47	00000000	00000000	00000000	00000000	00000000	00000000
SW48	00000000	00000000	00000000	00000000	00000000	00000000
SW49	00000000	00000000	00000000	00000000	00000000	00000000
SW50	00000000	00000000	00000000	00000000	00000000	00000000
#2 MENU						
05	OFF	OFF	OFF	OFF	OFF	OFF
06	DIAL	DIAL	DIAL	DIAL	DIAL	DIAL
07	10	10	10	10	13	10
08	3429baud	3429baud	3429baud	3429baud	3429baud	3429baud
09	33600bps	33600bps	33600bps	33600bps	33600bps	33600bps
10	25Hz	25Hz	25Hz	25Hz	25Hz	25Hz

T05-1201-10

TYPE	FRANCE	SINGAPORE	CZECH	SLOVENIA	CANADA	RESERVE 1
SW31	00000000	00000000	00000000	00000000	00000000	00000000
SW32	00000000	00000000	00000000	00000000	00000000	00000000
SW33	00000000	00000000	00000000	00000000	00000000	00000000
SW34	00000000	00000000	00000000	00000000	00000000	00000000
SW35	00000000	00000000	00000000	00000000	00000000	00000000
SW36	00000000	00000000	00000000	00000000	00000000	00000000
SW37	00000000	00000000	00000000	00000000	00000000	00000000
SW38	00000000	00000000	00000000	00000000	00000000	00000000
SW39	00000000	00000000	00000000	00000000	00000000	00000000
SW40	00000000	00000000	00000000	00000000	00000000	00000000
SW41	00000000	00000000	00000000	00000000	00000000	00000000
SW42	00000000	00000000	00000000	00000000	00000000	00000000
SW43	00000000	00000000	00000000	00000000	00000000	00000000
SW44	00000000	00000000	00000000	00000000	00000000	00000000
SW45	00000000	00000000	00000000	00000000	00000000	00000000
SW46	00000000	00000000	00000000	00000000	00000000	00000000
SW47	00000000	00000000	00000000	00000000	00000000	00000000
SW48	00000000	00000000	00000000	00000000	00000000	00000000
SW49	00000000	00000000	00000000	00000000	00000000	00000000
SW50	00000000	00000000	00000000	00000000	00000000	00000000
#2 MENU						
05	OFF	OFF	OFF	OFF	OFF	OFF
06	DIAL	DIAL	DIAL	DIAL	DIAL	DIAL
07	10	10	10	10	10	10
08	3429baud	3429baud	3429baud	3429baud	3429baud	3429baud
09	33600bps	33600bps	33600bps	33600bps	33600bps	33600bps
10	25Hz	25Hz	25Hz	25Hz	25Hz	25Hz

T05-1201-11

TYPE	RESERVE 2	ASIA	POLAND	EUROPE 2	TAIWAN
SW31	00000000	00000000	00000000	00000000	00000000
SW32	00000000	00000000	00000000	00000000	00000000
SW33	00000000	00000000	00000000	00000000	00000000
SW34	00000000	00000000	00000000	00000000	00000000
SW35	00000000	00000000	00000000	00000000	00000000
SW36	00000000	00000000	00000000	00000000	00000000
SW37	00000000	00000000	00000000	00000000	00000000
SW38	00000000	00000000	00000000	00000000	00000000
SW39	00000000	00000000	00000000	00000000	00000000
SW40	00000000	00000000	00000000	00000000	00000000
SW41	00000000	00000000	00000000	00000000	00000000
SW42	00000000	00000000	00000000	00000000	00000000
SW43	00000000	00000000	00000000	00000000	00000000
SW44	00000000	00000000	00000000	00000000	00000000
SW45	00000000	00000000	00000000	00000000	00000000
SW46	00000000	00000000	00000000	00000000	00000000
SW47	00000000	00000000	00000000	00000000	00000000
SW48	00000000	00000000	00000000	00000000	00000000
SW49	00000000	00000000	00000000	00000000	00000000
SW50	00000000	00000000	00000000	00000000	00000000
#2 MENU					
05	OFF	OFF	OFF	OFF	OFF
06	DIAL	DIAL	DIAL	DIAL	DIAL
07	10	10	10	10	10
08	3429baud	3429baud	3429baud	3429baud	3429baud
09	33600bps	33600bps	33600bps	33600bps	33600bps
10	25Hz	25Hz	25Hz	25Hz	25Hz

T05-1201-12

TYPE	USA	EUROPE	U.K	SWEDEN	SWISS	AUSTRIA
#3 NUMERIC						
02	10	10	10	10	10	10
03	15	15	15	15	15	15
04	12	12	12	12	12	12
05	4	4	4	0	0	0
06	4	4	1	0	0	0
07	0	0	0	0	0	0
08	0	0	0	0	0	0
09	6	6	6	6	6	6
10	5500	5500	5500	5500	5500	5500
11	3500	3500	3500	3500	3500	3500
12	0	0	0	0	0	0
13	1300	1300	1300	1300	1300	1300
14	0	0	0	0	0	0
15	120	120	120	120	120	120
16	4	2	2	2	2	2
17	100	100	40	100	100	100
18	0	0	20	0	0	0
19	200	400	200	400	400	400
20	100	100	40	100	100	100
21	0	0	20	0	0	0
22	200	400	200	400	400	400
23	4	44	44	44	44	44
24	20	10	10	10	10	10
25	60	60	60	60	60	60
26	4	4	5	5	5	5
27	0	0	0	0	0	0
28	0	0	0	0	0	0
29	0	0	0	0	0	0
30	0	20	20	20	20	20

T05-1201-13

CHAPTER 5 FAX KIT

TYPE	DENMARK	NORWAY	HOLAND	BELGIUM	AUSTRALIA	FINLAND
#3 NUMERIC						
02	10	10	10	10	10	10
03	15	15	15	15	15	15
04	12	12	12	12	12	12
05	0	0	0	0	0	0
06	0	0	0	0	0	0
07	0	0	0	0	0	0
08	0	0	0	0	0	0
09	6	6	6	6	6	6
10	5500	5500	5500	5500	5500	5500
11	3500	3500	3500	3500	3500	3500
12	0	0	0	0	0	0
13	1300	1300	1300	1300	1300	1300
14	0	0	0	0	0	0
15	120	120	120	120	120	120
16	2	2	2	2	2	2
17	75	30	100	100	100	100
18	0	30	0	0	0	0
19	250	400	400	300	400	400
20	100	30	100	100	100	100
21	0	30	0	0	0	0
22	400	400	400	300	400	400
23	44	44	44	44	44	44
24	10	10	10	10	10	12
25	60	60	60	60	60	60
26	5	5	5	5	5	5
27	0	0	0	0	0	0
28	0	0	0	0	0	0
29	0	0	0	0	0	0
30	20	20	20	20	20	20

T05-1201-14

TYPE	N.Z.	ITALY	SPAIN	PORTUGAL	IRELAND	HONG KONG
#3 NUMERIC						
02	10	10	10	10	10	10
03	15	15	15	15	15	15
04	12	12	12	12	12	12
05	0	0	15	0	0	4
06	0	0	3	0	0	1
07	0	0	0	0	0	0
08	0	0	0	0	0	0
09	6	6	6	6	6	6
10	5500	5500	5500	5500	5500	5500
11	3500	3500	3500	3500	3500	3500
12	0	0	0	0	0	0
13	1300	1300	1300	1300	1300	1300
14	0	0	0	0	0	0
15	120	120	120	120	120	120
16	2	2	2	2	2	2
17	40	30	150	40	40	40
18	20	30	0	20	20	20
19	200	400	300	200	200	200
20	40	30	150	40	40	40
21	20	30	0	20	20	20
22	200	400	300	200	200	200
23	44	44	44	44	44	44
24	10	10	10	10	10	10
25	60	60	60	60	60	60
26	5	5	5	5	3	5
27	0	0	0	0	0	0
28	0	0	0	0	0	0
29	0	0	0	0	0	0
30	20	20	20	20	10	20

T05-1201-15

CHAPTER 5 FAX KIT

TYPE	MALASIA	HUNGARY	SAF	KOREA	CHINA	GERMAN
#3 NUMERIC						
02	10	10	10	10	10	10
03	15	15	15	15	15	15
04	12	12	12	12	12	6
05	0	0	0	4	0	0
06	0	0	0	4	0	0
07	0	0	0	0	0	0
08	0	0	0	0	0	0
09	6	6	6	6	6	6
10	5500	5500	5500	5500	4500	9000
11	3500	3500	3500	3500	3500	3500
12	0	0	0	0	0	0
13	1300	1300	1300	1300	1300	1300
14	0	0	0	0	0	0
15	120	120	120	120	120	120
16	2	2	2	4	2	2
17	100	100	40	40	100	40
18	0	0	20	20	0	20
19	400	400	200	200	400	200
20	100	100	40	40	100	100
21	0	0	20	20	0	0
22	400	400	200	200	400	200
23	44	44	44	44	44	44
24	10	10	10	20	10	10
25	60	60	60	60	60	60
26	5	5	5	4	5	5
27	0	0	0	0	0	0
28	0	0	0	0	0	0
29	0	0	0	0	0	0
30	20	20	20	10	20	20

T05-1201-16

TYPE	FRANCE	SINGAPORE	CZECH	SLOVENIA	CANADA	RESERVE 1
#3 NUMERIC						
02	10	10	10	10	10	10
03	15	15	15	15	15	15
04	12	12	12	12	12	12
05	0	0	0	0	4	4
06	0	0	0	0	4	4
07	0	0	0	0	0	0
08	0	0	0	0	0	0
09	6	6	6	6	6	6
10	5500	5500	5500	5500	5500	5500
11	3800	3500	3500	3500	3500	3500
12	0	0	0	0	0	0
13	1300	1300	1300	1300	1300	1300
14	0	0	0	0	0	0
15	120	120	120	120	120	120
16	2	2	2	2	4	2
17	30	100	100	100	100	100
18	30	0	0	0	0	0
19	400	400	400	400	200	400
20	150	100	100	100	100	100
21	0	0	0	0	0	0
22	300	400	400	400	200	400
23	44	44	44	44	4	44
24	10	10	10	10	20	10
25	60	60	60	60	60	60
26	5	5	5	5	4	4
27	0	0	0	0	0	0
28	0	0	0	0	0	0
29	0	0	0	0	0	0
30	20	20	20	20	0	20

T05-1201-17

CHAPTER 5 FAX KIT

TYPE	RESERVE 2	ASIA	POLAND	EUROPE 2	TAIWAN
#3 NUMERIC					
02	10	10	10	10	10
03	15	15	15	15	15
04	12	12	12	12	12
05	4	4	4	4	4
06	4	4	4	4	4
07	0	0	0	0	0
08	0	0	0	0	0
09	6	6	6	6	6
10	5500	5500	5500	5500	5500
11	3500	3500	3500	3500	3500
12	0	0	0	0	0
13	1300	1300	1300	1300	1300
14	0	0	0	0	0
15	120	120	120	120	120
16	2	2	2	2	4
17	100	100	100	100	100
18	0	0	0	0	0
19	400	400	400	400	200
20	100	100	100	100	100
21	0	0	0	0	0
22	400	400	400	400	200
23	44	44	44	44	4
24	10	10	10	10	20
25	60	60	60	60	60
26	4	4	4	4	4
27	0	0	0	0	0
28	0	0	0	0	0
29	0	0	0	0	0
30	20	20	20	20	0

T05-1201-18

13 Test mode (#9 TEST)

Sssw	Menu	Num	Ncu	Type	ISDN	Print	Clear	Test	Report
------	------	-----	-----	------	------	-------	-------	-------------	--------

<READY>

MODEM

FACULTY



F05-1300-01

Operating method

- Press on the desired item. Once the item has been highlighted, press OK to display the window.

When each fax board is mounted, the valid and invalid test modes are displayed.

○: use ×: do not use ÷: not indicated

Main item	Sub item	When Super G3 FAX Board is mounted
MODEM	RELAY-1	○
	RELAY-2	×
	FREQ	○
	G3TX	○
	DTMFTX	○
	TONERX	×
	V34G3TX	○
FACULTY	G34800TX	○
	SPEAKER	×
	LINE DETECT1	×
	LINE DETECT2	×
	LINE DETECT3	×
	VOICETX	○

T05-1300-01



Items marked '×' in the table are not supported and therefore do not work. If an attempt is made to use these items, some of them will not be able to return to the test mode window. In that case, turn the main unit power OFF/ON to return to normal.

13.1 MODEM test

13.1.1 Relay test (RELAY-1)

Tests the ON/OFF of the relays on the NCU board.

Ssw	Menu	Num	Ncu	Type	ISDN	Print	Clear	Test	Report
<MODEM>	<RELAY-1>				<1/1>			<READY>	
CML			OFF						
P			OFF						
S			OFF						
H			OFF						
D			OFF						
R			OFF						







F05-1301-01

Operating method

- 1) Select the relay to be tested from the window display and use the up/ down keys to toggle between ON and OFF. Note that some of the displayed relays are not mounted on the NCU.

13.1.2 Frequency test (FREQ)

Choose one item only from the list displayed below. This will close the direct current circuit and the selected frequency will be sent using the modem's tone output function. At the same time, the output signal from the speaker is monitored. To stop the operation, press the  key and the test mode will stop.

Sssw	Menu	Num	Ncu	Type	ISDN	Print	Clear	Test	Report
<MODEM>	<FREQ>	<1/1>	<READY>						
RBT									
462Hz									
1100Hz									
1300Hz									
1500Hz									
1650Hz									
1850Hz									
2100Hz									
									







F05-1301-02



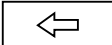





The above items do not support RBT.

13.1.3 G3 Fax signal output test (G3TX)

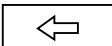
Choose one item only from the list displayed below. This will close the direct current circuit and the selected signal will be sent using the modem's G3 signal output function. At the same time, the output signal from the speaker is monitored. To stop the operation, press the  key and the test mode will stop.

Sssw	Menu	Num	Ncu	Type	ISDN	Print	Clear	Test	Report
	<MODEM>		<G3TX>			<1/2>			<READY>
	300bps 2400bps 4800bps 7200bps 9600bps TC7200 TC9600 12000bps								
     									

F05-1301-03

Sssw	Menu	Num	Ncu	Type	ISDN	Print	Clear	Test	Report
	<MODEM>		<G3TX>			<2/2>			<READY>
	14400bps 300-ALLO 300-ALL1 300-1:1 300-1:4 300-4:1								
     									

F05-1301-04







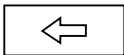

The above items do not support from '300 -ALLO' to '300 -4:1'.

13.1.4 DTMF output test

Choose one item only from the list displayed below. This will close the direct current circuit and the selected DTMF will be sent using the modem's DTMF output function. At the same time, the output signal from the speaker is monitored. To stop the operation, press the  key and the test mode will stop.

Sssw	Menu	Num	Ncu	Type	ISDN	Print	Clear	Test	Report
<MODEM>	<DTMF>	<1/1>	<READY>						
LONG		0 1 2 3 4 5 6 7 8 9 * #							
SHORT		0 1 2 3 4 5 6 7 8 9 * #							

F05-1301-05

Operating method





- 1) Select the item to be tested from the window display and press the numeric key corresponding to the DTMF signal to be tested.

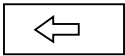
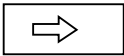

The above items do not support 'SHORT'.

13.1.5 V.34 G3 signal output test (V34G3Tx)

Select the transmission speed to be tested and the modulation speed (Baud rate). The V.34 G3 transmission signal will be sent to the telephone line connection terminal and to the speaker. To stop the operation, press the  key and the test mode will stop.

Sssw	Menu	Num	Ncu	Type	ISDN	Print	Clear	Test	Report
	<MODEM>			<V34G3TX>		<1/1>		<READY>	
	SPEED			33600bps					
	3429baud								
	3200baud								
	3000baud								
	2800baud								
	2743baud								
	2400baud								
									
								OK 	

F05-1301-06

Operating method

- 1) Select 'SPEED' and then use the UP/DOWN keys to select the speed.
- 2) Select the Baud rate to be tested.

13.2 Function tests

13.2.1 4800bps signal output test

The direct current circuit is closed and the 4800bps signal is sent using the modem's 4800bps signal transmission function.

At the same time, the transmission signal output from the speaker is monitored.

To stop the operation, press the  key and the test mode will stop.

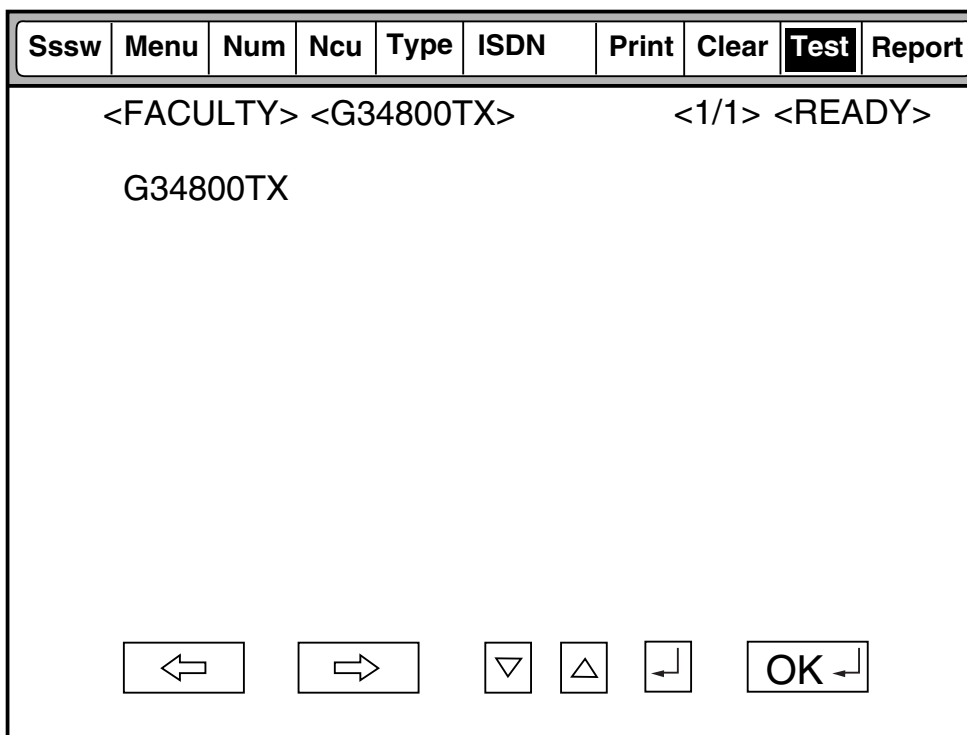

F05-1302-01

13.2.2 OGM test

The OGM built into the voice IC is played.

Sssw	Menu	Num	Ncu	Type	ISDN	Print	Clear	Test	Report
<FACULTY>		<VOICETX>		<1/1>		<READY>			
VOICE1									
VOICE2									
									

F05-1302-02

Operating method

1) Select the message to be tested.

VOICE1

“The telephone is ringing. If you are sending a fax, please wait a few moments.”

VOICE2

“No-one is available to take your call. If you are sending a fax, please wait a few moments.”

14 Service reports

14.1 System data lists

These lists show the current service soft switch and service parameter settings.

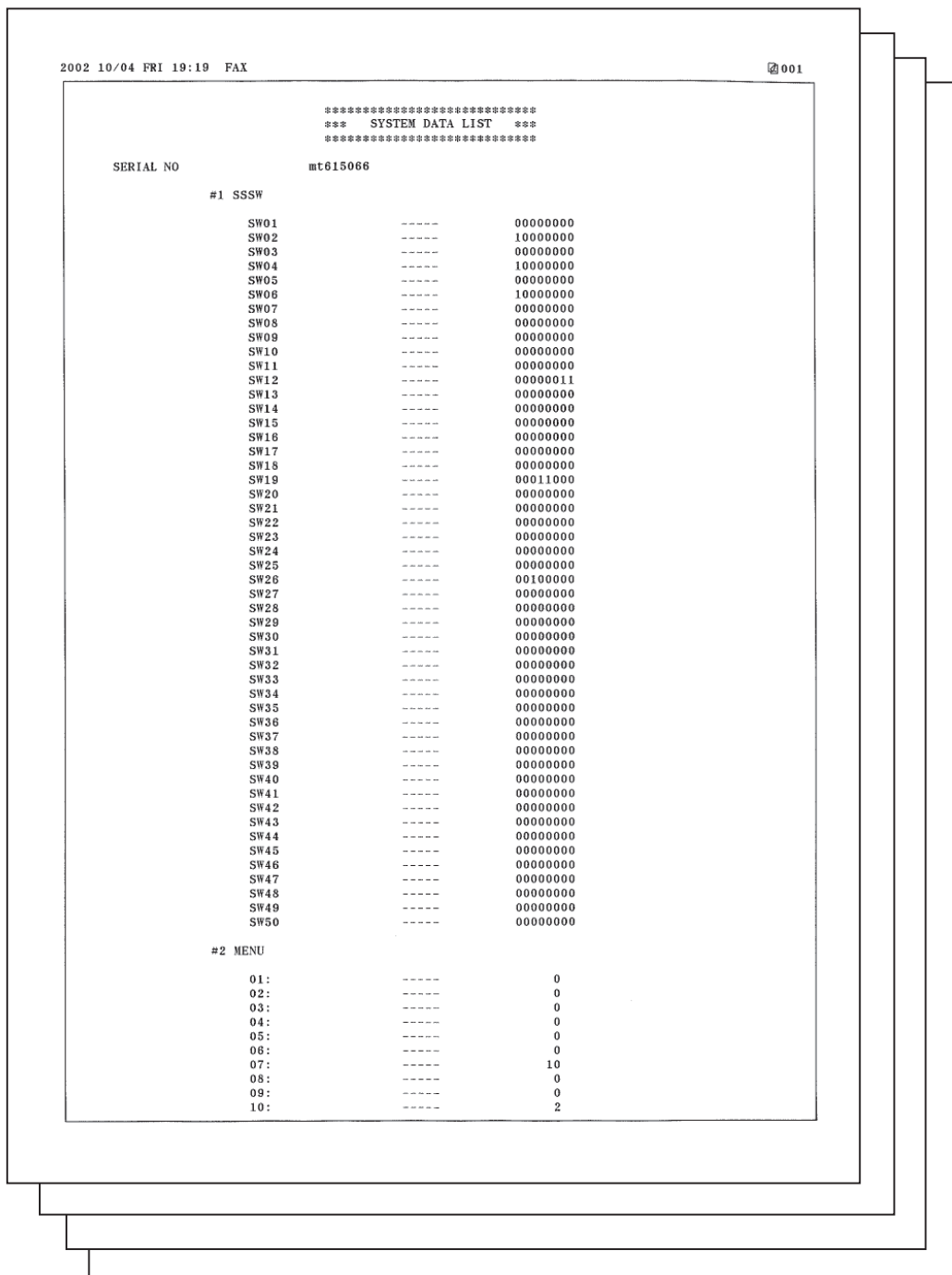

F05-1401-01

- *1: RX: Total reception pages, TX: Total transmission pages
- *2: Tx/ Rx histories for each document size
- *3: Tx/ Rx histories for each modem speed (standard/ fine/ superfine/ ultrafine)
- *4: Tx/ Rx pages for each mode
- *5: Tx/ Rx pages for each encoding system
- *6: Tx/ Rx count for each mode
- *7: Occurrence count for each error code

Example

##280	1	7	3	0	0
	##280 error	##281 error	##282 error		
	count	count	count		

Error information for the three most recent activities is shown.

```

2001 05/17 木 12:48 FAX 003

*1 —— #1 LATEST ##755

*2 ———— START TIME 05/11 9:51
*3 ———— OTHER PARTY 32125
*4 ———— MAKER CODE 10001000
*5 ———— MACHINE CODE 01101110 00000000
          RCV V.8 FRAME E0 81 85 D4 90 7E 00 00
          SYMBOL RATE 3429 baud
          DATA RATE 26400 bps [V.34]
          TX LVL REDUCTION 0
          ERR ABCODE 92
          ERR SECTXB 8a
          ERR SECRXB 80

*6 ———— Rx : (bit 1) 00000100 01110111 01010001 00100011 00000001 10101011 11000001 (bit 56)
          (bit 57) 00000001 00000001 00000100 00000000 00000000 (bit 96)
*7 ———— Tx : (bit 1) 00000000 01000000 00011111 00100001 00000001 00000001 00000001 (bit 56)
          (bit 57) 00000001 00000001 00000100 00000000 00000000 (bit 96)

*8 ———— Rx : NSF CSI DIS CFR PPR
          Tx : NSS DCS PIX-264 PPS-MPS PIX-264 PPS-MPS PPS-MPS PPS-MPS DCN

          Rx :
          Tx :

#2 ##674

          START TIME 05/14 15:16
          OTHER PARTY 32125
          MAKER CODE 00000000
          DATA RATE
          Rx : (bit 1) 00000000 00000000 00000000 00000000 00000000 00000000 00000000 (bit 56)
          (bit 57) 00000000 00000000 00000000 00000000 00000000 (bit 96)
          Tx : (bit 1) 00000000 00000000 00000000 00000000 00000000 00000000 00000000 (bit 56)
          (bit 57) 00000000 00000000 00000000 00000000 00000000 (bit 96)

          Rx :
          Tx :

#3 OLDEST ##673

          START TIME 05/14 19:39
          OTHER PARTY
          MAKER CODE 00000000
          DATA RATE
          Rx : (bit 1) 00000000 00000000 00000000 00000000 00000000 00000000 00000000 (bit 56)
          (bit 57) 00000000 00000000 00000000 00000000 00000000 (bit 96)
          Tx : (bit 1) 00000000 00000000 00000000 00000000 00000000 00000000 00000000 (bit 56)
          (bit 57) 00000000 00000000 00000000 00000000 00000000 (bit 96)

          Rx :
          Tx : DCN
    
```

F05-1402-02

- *1: Service error codes
- *2: START TIME: Date and time (displayed in 24 hour notation)
- *3: OTHER PARTY: Telephone number declared by other party
- *4: MAKER CODE: Manufacturer's code
- *5: MACHINE CODE: Machine specific code
- *6: Bits 1 to 96 for received DIS, DCS or DTC
- *7: Bits 1 to 96 for received DIS, DCS or DTC
- *8: RX = Received protocol signals
TX = Transmitted protocol signals

14.3 TX error report

This report has the service error codes and error dump list attached to the transmission error report.

05/22/2001 TUE 09:18 FAX

001

```

*****
***  ERROR TX REPORT  ***
*****

TX FUNCTION WAS NOT COMPLETED

JOB NO.           0132
DESTINATION ADDRESS 32126
PSWD/SUBADDRESS
DESTINATION ID
ST. TIME          05/22 09:17
USAGE T           00'51
PGS.              1
RESULT            NG      ##765
    
```

```

START TIME        05/22 9:17
OTHER PARTY       32126
MAKER CODE        10001000
MACHINE CODE      10101010 00000000
RCV V.8 FRAME     E0 81 85 D4 90 7E 00 00
SYMBOL RATE       3429 baud
DATA RATE         24000 bps [V.34]
TX LVL REDUCTION  0
ERR ABCODE        92
ERR SECTXB        8a
ERR SECRXB        80
    
```

```

Rx : (bit 1)  00000100 01110011 01010101 00100011 00000001 10101011 11000001 (bit 56)
      (bit 57) 00000001 00000001 00000100 00000000 00000000 00000000 (bit 96)
Tx : (bit 1)  00000000 01000000 00011111 00100001 00000001 00000001 00000001 (bit 56)
      (bit 57) 00000001 00000001 00000100 00000000 00000000 (bit 96)
    
```

Rx :	NSF CSI DIS	CFR	PPR	PPR
Tx :	NSS DCS	PIX-240 PPS-EOP PPS-EOP	PIX-240 PPS-EOP PPS-EOP	
Rx :				
Tx :	PIX-240 PPS-EOP PPS-EOP PPS-EOP DCN			

F05-1403-01

15 Service error codes output

When this board is mounted and service data #1 SSSW SW01 Bit 0 is set to '1', if a communication finishes in error, the service error code will be attached to the activity management report, the reception results report and the transmission error report. Also, when an error occurs, the error code can be checked by the following procedure.

System status → Stop → Fax → Detailed information → Status

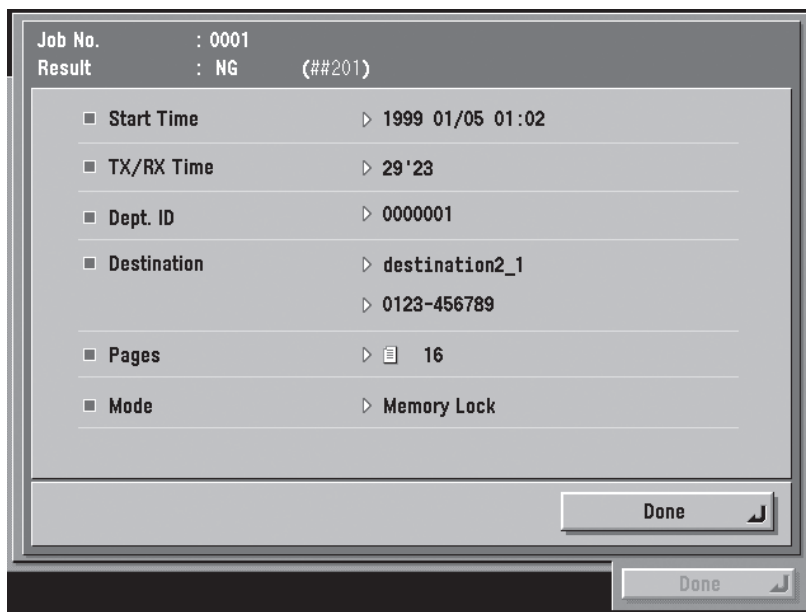

The screenshot displays a service error code output screen with the following information:

Job No.	: 0001
Result	: NG (##201)
Start Time	▷ 1999 01/05 01:02
TX/RX Time	▷ 29'23
Dept. ID	▷ 0000001
Destination	▷ destination2_1 ▷ 0123-456789
Pages	▷ 16
Mode	▷ Memory Lock

Buttons: Done (bottom right)

F05-1500-01

16 Error codes

The main error codes displayed by this board are listed in 1.2.3.

The causes and countermeasures of other error codes are given in the separate volume 'G3/ G4 Facsimile Error Codes Service Handbook (Revision 2)', material number : HY8-22A6-020.

The countermeasures for this board for service error codes are given below.

- **Raise transmission level**

Set service data #2 MENU parameter No. 7 to -8 (dBm).

- **Lower transmission level**

Set service data #2 MENU parameter No. 7 to -15 (dBm).

- **Echo countermeasures**

Change the settings of the following bits of service data #1 SSSW SW03.

Bit 4 → 1: First DIS from the other party is ignored.

→ 0: First DIS from the other party is not ignored.

Bit 5 → 1: When the other party sends DIS, a tonal signal (1850 or 1650Hz) is sent.

→ 0: When the other party sends DIS, a tonal signal (1850 or 1650Hz) is not sent.

Bit 6 → 1: When Bit 5 is 1, the transmitted tonal signal is 1850Hz.

→ 0: When Bit 5 is 1, the transmitted tonal signal is 1650Hz.

Bit 7 → 1: Before transmitting CED, a tonal signal is sent.

→ 0: Before transmitting CED, a tonal signal is not sent.

- **EPT (Echo Protect Tone)**

Change the settings of service data #1 SSSW SW03 Bit 1.

Bit 1 → 1: Send EPT.

→ 0: Do not send EPT.

- **NL equalizer adjustment**

Set parameter No.05 of service data #2 MENU to 'ON'.

- **Lower transmission start speed**
Lower the transmission start speed with the sequence System management settings → Activity management settings → Transmission start speed in the user mode.

- **Relax TCF judgement criteria**
This board does not support this countermeasure.

- **Relax RTN transmission conditions**
Change service data #3 NUMERIC Param. parameters No. 2 to No. 4.
No. 2 Error rate for all lines: close to 99%
No. 3 Line count for burst status: close to 99 lines
No. 4 Error count for fewer than burst error lines: close to 99 lines

- **Extend length of no-sound period after receiving CFR.**
Change service data #1 SSSW SW04 Bit 4 to 1.
Bit 4 → 1: After sending CFR, ignore low speed signals for 1500ms.
→ 0: After sending CFR, ignore low speed signals for 700ms.

17 Error code list

- User error codes

No.	Tx / Rx	Meaning
#001	[Tx]	Document jam
#003	[Tx / Rx]	One page copy/ Tx/ Rx time over
#005	[Tx / Rx]	Initial identification (T0/ T1) time over
#008	[Rx]	Incorrect polling transmission password
#009	[Rx]	Paper jam/ no paper
#012	[Tx]	No paper in other party machine
#018	[Tx / Rx]	Automatic dialling error
#022	[Tx]	Cannot dial
#037	[Rx]	Image memory over in reception
#080	[Tx]	Other party machine does not have F code reception function/ function is not set
#081	[Tx]	Other party machine does not have password reception function/ function is not set
#099	[Tx / Rx]	Stop key pressed during transmission
#102	[Tx / Rx]	Incorrect F code/ password
#995	[Tx / Rx]	Memory transmission reservation cancelled

• Service error codes (G3)

No.	Tx / Rx	Meaning
##001	[Tx]	Protocol signal retry count exceeded in transmission.
##101	[Tx / Rx]	Modem speed does not match that of other party.
##102	[Tx]	Cannot fall back in transmission.
##103	[Rx]	EOL cannot be detected for 5 seconds during reception (15 sec. in the case of CBT).
##104	[Tx]	RTN or PIN received in transmission
##106	[Rx]	Cannot receive protocol signals after waiting 6 seconds in reception.
##107	[Rx]	Transmitting side cannot fall back in reception.
##109	[Tx]	Signals other than DIS, DTC, FTT or CRP are received after sending DCS in transmission, and the protocol signal retry count has been exceeded.
##111	[Tx / Rx]	Memory error
##114	[Rx]	RTN sent in reception/
##200	[Rx]	Carrier not detected for 5 seconds during image reception.
##201	[Tx / Rx]	DCN received in other than normal binary protocol.
##204	[Tx]	DTC received without any transmission data.
##220	[Tx / Rx]	System error (main programme locked up).
##223	[Tx / Rx]	Line disconnected while communicating.
##224	[Tx / Rx]	Abnormality in protocol signals during G3 communication.
##226	[Tx / Rx]	Stack pointer out of RAM area.
##229	[Rx]	Printing assembly locked for one minute.
##232	[Tx]	Encoding error
##237	[Rx]	Decoding error
##238	[Rx]	Print control unit fault
##261	[Tx / Rx]	System error between modem and SCNT.
##280	[Tx]	Protocol signal retry count exceeded in transmission.
##281	[Tx]	Protocol signal retry count exceeded in transmission.
##282	[Tx]	Protocol signal retry count exceeded in transmission.
##283	[Tx]	Protocol signal retry count exceeded in transmission.
##284	[Tx]	TCF received after sending DCN in transmission.
##285	[Tx]	EOP received after sending DCN in transmission.
##286	[Tx]	EOM received after sending DCN in transmission.
##287	[Tx]	MPS received after sending DCN in transmission.
##288	[Tx]	Signals other than PIN, PIP, MCF, RTP, RTN are received after sending EOP.
##289	[Tx]	Signals other than PIN, PIP, MCF, RTP, RTN are received after sending EOP.
##290	[Tx]	Signals other than PIN, PIP, MCF, RTP, RTN are received after sending EOP.

No.	Tx / Rx	Meaning
##670	[Tx]	At V.8 rate start time, V.8 capabilities are detected in the DIS from the receiver and CI is sent, but the protocol does not proceed beyond this and the line is released after T1 timeout.
##671	[Rx]	Upon V.8 calling, after detecting the calling side's CM signal, the protocol does not proceed beyond Phase 2 and the line is released after T1 timeout.
##672	[Tx]	Upon V.34 transmission, the protocol does not proceed from Phase 2 to Phase 3 and the line is released after T1 timeout.
##673	[Rx]	Upon V.34 reception, the protocol does not proceed from Phase 2 to Phase 3 and the line is released after T1 timeout.
##674	[Tx]	Upon V.34 transmission, the protocol does not advance from Phase 3 and Phase 4 to the control channel and beyond and the line is released after T1 timeout.
##675	[Rx]	Upon V.34 reception, the protocol does not advance from Phase 3 and Phase 4 to the control channel and beyond and the line is released after T1 timeout.
##750	[Tx]	In ECM transmission, after emitting PPS-NULL, protocol signal retry is exceeded.
##752	[Tx]	In ECM transmission, after emitting PPS-NULL, DCN is received.
##753	[Tx]	In ECM transmission, after emitting PPS-NULL, protocol signal retry is exceeded or T5 timer (60 seconds) times out.
##754	[Tx]	In ECM transmission, after emitting PPS-NULL, protocol signal retry is exceeded
##755	[Tx]	In ECM transmission, after emitting PPS-MPS, no meaningful signals are received and the protocol signal retry is exceeded
##757	[Tx]	In ECM transmission, after emitting PPS- MPS, DCN is received.
##758	[Tx]	In ECM transmission, after emitting PPS- MPS, protocol signal retry is exceeded or T5 timer (60 seconds) times out.
##759	[Tx]	In ECM transmission, after emitting PPS- MPS, protocol signal retry is exceeded
##760	[Tx]	In ECM transmission, after emitting PPS-EOM, no meaningful signals are received and the protocol signal retry is exceeded
##762	[Tx]	In ECM transmission, after emitting PPS- EOM, DCN is received.
##763	[Tx]	In ECM transmission, after emitting PPS- MPS, protocol signal retry is exceeded or T5 timer (60 seconds) times out.
##764	[Tx]	In ECM transmission, after emitting PPS- EOM, protocol signal retry is exceeded.
##765	[Tx]	In ECM transmission, after emitting PPS- EOP, no meaningful signals are received and the protocol signal retry is exceeded.
##767	[Tx]	In ECM transmission, after emitting PPS- EOP, DCN is received.

No.	Tx / Rx	Meaning
##768	[Tx]	In ECM transmission, after emitting PPS-EOP, protocol signal retry is exceeded or T5 timer (60 seconds) times out.
##769	[Tx]	In ECM transmission, after emitting PPS-EOP, protocol signal retry is exceeded.
##770	[Tx]	In ECM transmission, after emitting EOR-NULL, no meaningful signals are received and the protocol signal retry is exceeded.
##772	[Tx]	In ECM transmission, after emitting EOR-NULL, DCN is received.
##773	[Tx]	In ECM transmission, after emitting EOR-NULL, protocol signal retry is exceeded or T5 timer (60 seconds) times out.
##774	[Tx]	In ECM transmission, after emitting EOR-NULL, ERR is received.
##775	[Tx]	In ECM transmission, after emitting EOR-MPS, no meaningful signals are received and the protocol signal retry is exceeded.
##777	[Tx]	In ECM transmission, after emitting EOR-MPS, DCN is received.
##778	[Tx]	In ECM transmission, after emitting EOR-MPS, protocol signal retry is exceeded or T5 timer (60 seconds) times out.
##779	[Tx]	In ECM transmission, after emitting EOR-MPS, ERR is received.
##780	[Tx]	In ECM transmission, after emitting EOR-EOM, no meaningful signals are received and the protocol signal retry is exceeded.
##782	[Tx]	In ECM transmission, after emitting EOR-EOM, DCN is received.
##783	[Tx]	In ECM transmission, after emitting EOR-EOM, protocol signal retry is exceeded or T5 timer (60 seconds) times out.
##784	[Tx]	In ECM transmission, after emitting EOR-EOM, ERR is received.
##785	[Tx]	In ECM transmission, after emitting EOR-EOP, no meaningful signals are received and the protocol signal retry is exceeded.
##787	[Tx]	In ECM transmission, after emitting EOR-EOP, DCN is received.
##788	[Tx]	In ECM transmission, after emitting EOR-EOP, protocol signal retry is exceeded or T5 timer (60 seconds) times out.
##789	[Tx]	In ECM transmission, after emitting EOR-EOP, ERR is received.
##790	[Rx]	In ECM reception, after receiving EOR-Q, ERR is sent.
##791	[Tx / Rx]	In ECM mode protocol, non-meaningful signals are received.
##792	[Rx]	In ECM reception, PPS-NULL cannot be detected between partial pages.
##793	[Rx]	In ECM reception, when receiving high speed signals, a valid frame cannot be received and the timer times out.
##794	[Tx]	In ECM reception, an all-0 PPR signal is received.
##795	[Tx / Rx]	A fault occurs in decoding processing in transmission.
##796	[Tx / Rx]	A fault occurs in decoding processing after ECM reception.

CHAPTER 6

UFR PRINTER AND SCANNER KIT-A1

1 Product Outline

This kit comprises the following components.

- UFR board
- UFR software CD ROM unit
- Colour N/W ScanGear CR ROM unit
- System CD ROM

2 Specifications and Functions

This kit uses the host's UFR driver and creates a UFR Display List (intermediate language file), transfers it to the UFR board and then performs rendering and output.

Its main features are that the time to printing is faster and the output results are very close to the window display.

The main specifications and features of the kit are as shown below.

2.1 Specifications

- Data processing resolution: 600dpi
- Full colour mode/ monochrome mode available
- Valid printing area
Main scanning direction: 2.5mm Sub scanning direction: 2.5mm
- Supported OS
Windows2000 Professional/ Server/ Advanced Server
WindowsXP Home Edition/ Professional
Windows98/ 98SE/ Me
- Paper sizes
Standard paper sizes

Paper	Unit	Paper size (width × height) Upper: [mm] Lower: [dot]	Valid printing area (width × height) Upper: [mm] Lower: [dot]	Valid printing area (Area [mm ²])	Margin			
					Upper: [mm]	Lower: [dots]	(Left)	(Upper)
A3		297.0×420.0	292.0×415.0	121,180	2.5	2.5	2.5	2.5
	600DPI	7,014×9,920	6,894×9,800		60	60	60	60
A4		210.0×297.0	205.0×292.0	59,860	2.5	2.5	2.5	2.5
	600DPI	4,960×7,014	4,840×6,894		60	60	60	60
A5		148.0×210.0	143.0×205.0	29,315	2.5	2.5	2.5	2.5
	600DPI	3,496×4,960	3,376×4,840		60	60	60	60
B4 (JIS)		257.0×364.0	252.0×359.0	90,468	2.5	2.5	2.5	2.5
	600DPI	6,070×8,598	5,950×8,478		60	60	60	60
B5 (JIS)		182.0×257.0	177.0×252.0	42,484	2.5	2.5	2.5	2.5
	600DPI	4,298×6,070	4,178×5,950		60	60	60	60

T06-201-01

Paper	Unit	Paper size	Valid printing	Valid printing	Margin			
		(width × height) Upper: [mm] Lower: [dot]	area (width × height) Upper: [mm] Lower: [dot]	area (Area [mm ²])	(Left)	(Upper)	(Right)	(Lower)
Executive		184.2×266.7	179.2×261.7	44,718	2.5	2.5	2.5	2.5
	600DPI	4,350×6,300	4,230×6,180		60	60	60	60
Legal		215.9×355.6	210.9×350.6	71,159.04	2.5	2.5	2.5	2.5
	600DPI	5,100×8,400	4,980×8,280		60	60	60	60
Letter		215.9×279.4	210.9×274.4	55,469.46	2.5	2.5	2.5	2.5
	600DPI	5,100×6,600	4,980×6,480		60	60	60	60
SRA3		320.0×450.0	315.0×445.0	140,175	7.5	7.5	2.5	2.5
	600DPI	7,558×10,628	7,438×10,508		180	180	60	60
12 × 18		304.8×457.2	299.8×452.2	135,569	2.5	2.5	2.5	2.5
	600DPI	7,200×10,800	7,080×10,680		60	60	60	60
Monarch		98.4×190.5	93.4×185.5	17,325	2.5	2.5	2.5	2.5
	600DPI	4,500×2,324	4,380×2,204		60	60	60	60
B5 ISO		176.0×250.0	171.0×245.0	41,895	2.5	2.5	2.5	2.5
	600DPI	4,156×5,904	4,036×5,784		60	60	60	60
Postcard (JP)		100.0×148.0	90.0×138.5	12,465	2.5	2.5	2.5	2.5
	600DPI	2,362×3,496	2,240×3,376		60	60	60	60
Reply-paid postcard horizontal (JP)		148.0×200.0	143.0×195.0	27,885	2.5	2.5	2.5	2.5
	600DPI	3,496×4,724	3,376×4,604		60	60	60	60
4 sided postcard (JP)		200.0×296.0	195.0×291.0	56,745	2.5	2.5	2.5	2.5
	600DPI	4,724×6,992	4,604×6,872		60	60	60	60
Long envelope size 3 (JP)		120.0×235.0	115.0×230.0	26,450	10	10	10	10
	600DPI	2,834×5,551	2,714×5,431		240	240	240	240
Long envelope size 2 (JP)		240.0×332	235.0×327.0	76,845	10	10	10	10
	600DPI	5,668×7,842	5,548×7,722		240	240	240	240

T06-201-02

• Non-standard paper

User-defined paper size

(Figures in parentheses are area [mm²] –rounded to first decimal place)

Minimum (1/10[mm])	Maximum (1/10[mm])
1,000 × 1,480 (14,800)	3,060 × 4,570 (139,842)

Height and width 1/10[mm] (Japanese)

Height must always be equal to or greater than width.

- In dot conversion, roundness errors sometimes occur.
 - The device font cannot be used.
 - Because of the image driver, the device font is not used.
 - GDI raster fonts cannot be used.
 - 1 byte fonts: Courier, MS Sans Serif, MS Serif, etc.
 - 2 byte fonts: FixedSys, System, Small Fonts, Terminal, etc.
 - GDI vector fonts can be used.
 - 1 byte fonts: Modern, Roman, Script, etc.
 - True Type fonts can be used.
 - 1 byte fonts: Arial, Courier New, Symbol, Times New Roman, etc.
 - 2 byte fonts: MS Mincho, MS Gothic, etc.
 - WIFE fonts can be used.
 - 1 byte fonts: \$JS Mincho, \$JS Gothic, etc.
 - 2 byte fonts: JS Mincho, JS Gothic, etc.

2.2 New functions

2.2.1 Image data flow

The image data flow is as described below.

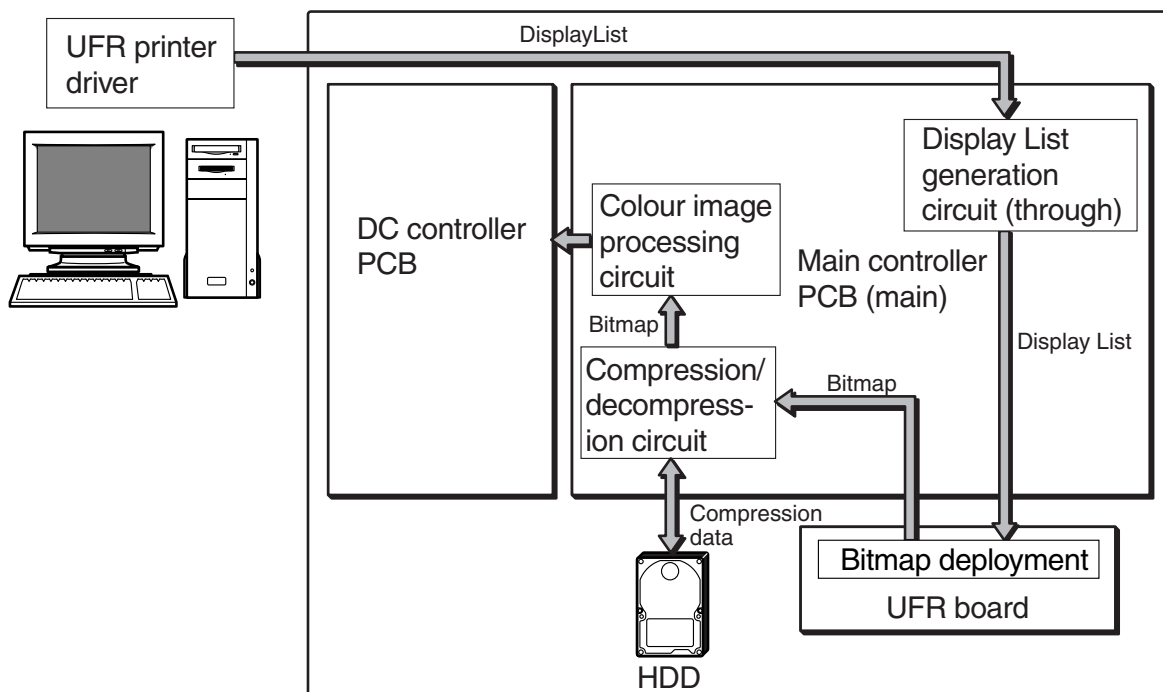

F06-202-01

2.2.2 Printing purpose

The image is processed and printed according to the printing purpose. (Text, Photo, DTP, Graphics, CAD)

2.2.3 Toner saving

Set whether to save toner by reducing the amount of toner used.

2.2.4 Super smooth

Allows setting of whether to use Super Smoothing Technology.

2.2.5 Gradation settings

Allows setting of whether to use gradation smoothing. When gradation smoothing is set, colour gradation is printed very smoothly.

3 Cautions when performing field service/ Reference items

When performing service on this kit in the field, note the following cautions and reference items.

3.1 Cautions when installing

- Make sure that the main unit network settings are completed.
- Make sure that the 'Extension' button is displayed on the main unit control panel.
- Make sure that the printer driver and ScanGear have been installed on the PC.
- When using Netware, the system needs to be changed. For details, refer to the installation procedures.
- After installation, perform 'Automatic gradation correction' from the main unit user mode.

3.2 Other cautions

- The Japanese postcard size, reply-paid postcard size and 4 sided postcard size are not defined paper sizes in Windows. Therefore, depending on the application software, you may not be able to select the appropriate paper size.
With regard to paper size and margin size, depending on calculation errors in the system, application software and driver, or due to the paper feed accuracy of the printer, paper shrinkage or stretching caused by heat and or humidity, the actual sizes may be greater or smaller than the specified or desired size.
- Supported fonts can be used by adding to the Windows fonts.

CHAPTER 7

RESOLUTION SWITCHING BOARD-A1

1 Product Outline

The product configuration of this kit is as shown below.

- Resolution switching board A1

2 Specifications and Functions

This kit is an optional board that adds the following functions.

- G3 Fax function (Used in conjunction with Super G3 FAX board M1)
- Transmission function (Used in conjunction with Color Universal send kit-A1P/A1U)

The main functions of the kit are as follows.

- Huffman encoding and decoding
- JBIG encoding and decoding
- Binary resolution conversion function (using bicubic method)

3 Cautions when performing field service/Reference items

When performing service on this kit in the field, note the following cautions and reference items.

3.1 Cautions when installing

None.

3.2 Other cautions

None.

CHAPTER 8

COLOR UNIVERSAL SEND KIT-A1P/A1U

1 Product configuration

The product composition of the kit is as follows.

- USB dongle (Color Universal Send kit A1U only)
- Parallel dongle (Color Universal Send kit A1P only)
- Setup tool (CD ROM)
- Serial number label

2 Specifications and functions

The main specifications and functions of the kit are as shown below.

2.1 Specifications

Resolution (selected from control panel)

100 × 100, 150 × 150, 200 × 100, 200 × 200, 200 × 400, 300 × 300, 360 × 360,
400 × 400, 600 × 600

Transmission functions

E-mail

I-FAX (Simple, Full) (colour transmission and reception not supported)

FTP

Canon FTP

SMB

NCP

Supported OS

Windows 95 (OSR2.5)/ 98/ ME

Windows NT 4.0 Workstation/ Server +SP6a

Windows 2000 Professional/ Server + SP1

Mac OS 8.5 + 8.5 update + 8.5.1 update

Netware 3.20

Netware 4.1, 4.11

Netware 5+ SPia

Sun Solaris (SPARC) 2.6

Supported applications

E-mail

Sendmail 8.93

Exchange Server 5.5 + Sp1

Domino R4.6

FTP IIS 4.0 and later

2.2 Functions

2.2.1 Monochrome transmission (E-mail, file transfer) data flow

Image data flow along the data paths shown below during E-mail and file transfer transmissions and then go via the Ethernet board to the network. The compression system used during transmission is MMR.

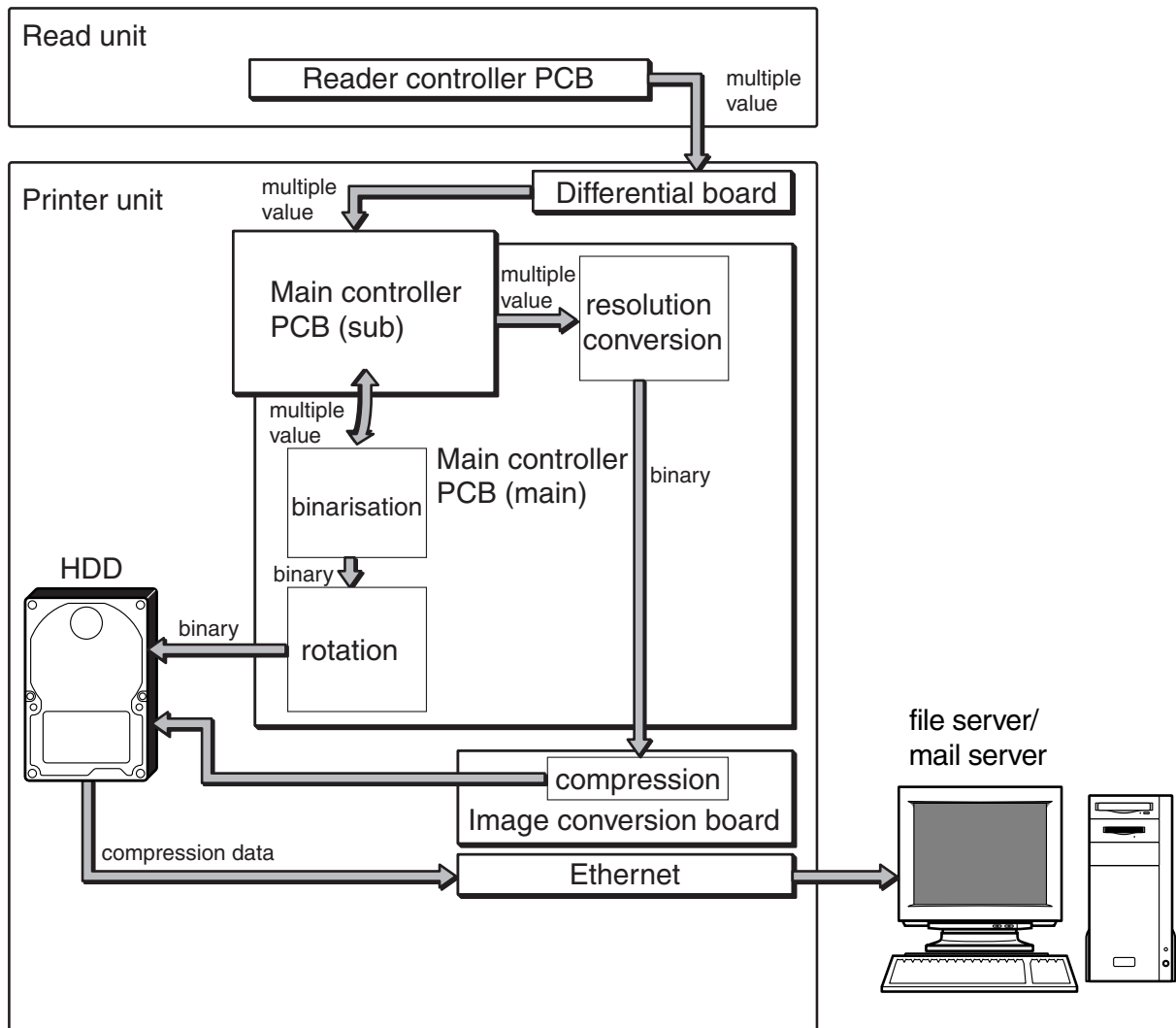

F08-202-01

2.2.2 Colour transmission (E-mail, file transfer) data flow

Image data flow along the data paths shown below during E-mail and file transfer transmissions and then go via the Ethernet board to the network. The compression system used during transmission is JPEG.

Colour transmission uses multiple value data conversion, so the image conversion board is not used.

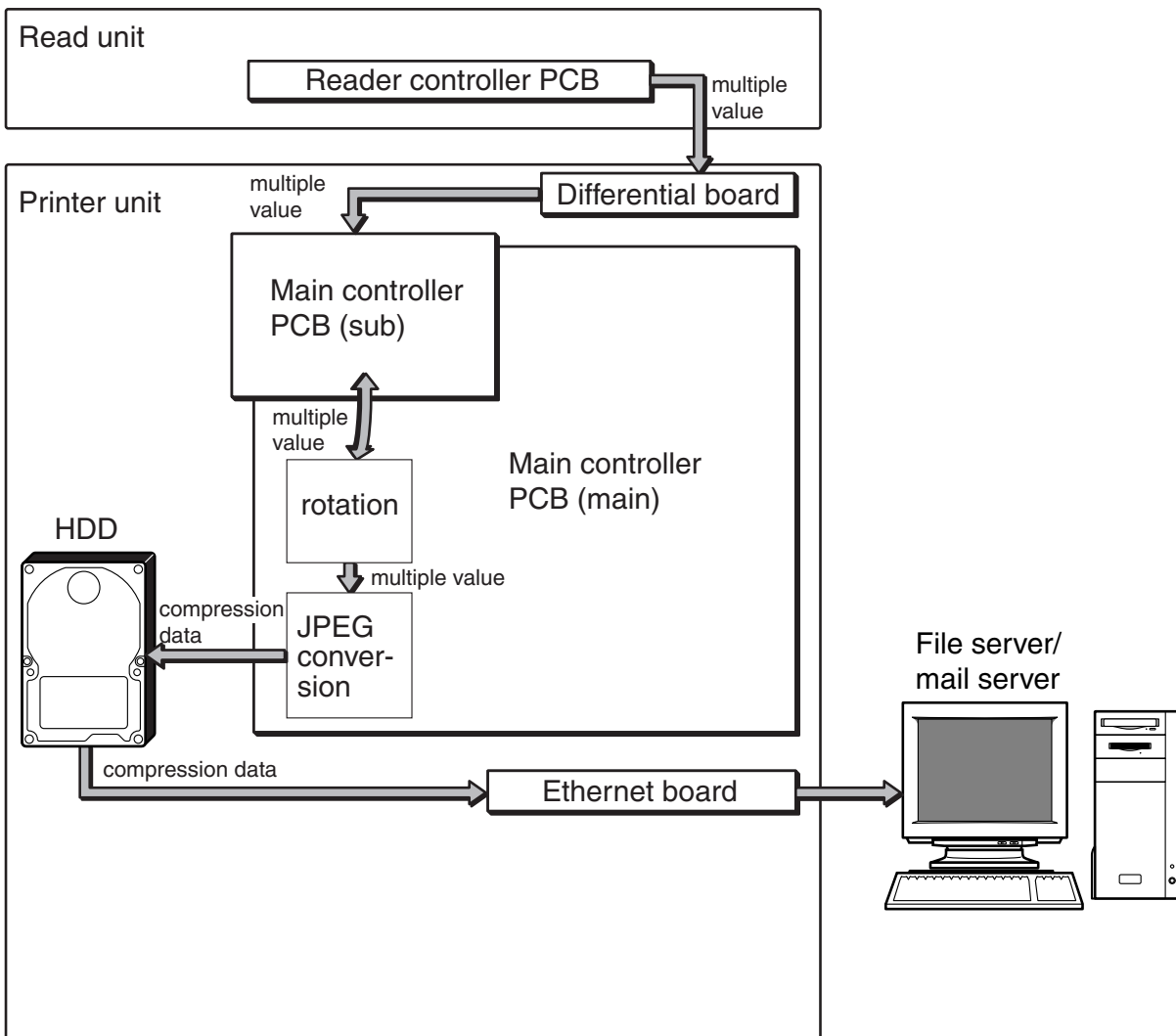

F08-202-02

2.2.3 I-FAX transmission data flow

In I-FAX transmission, the image data follow the path described below and flow to the network via the Ethernet board. The compression method used in transmission will be MH, MR or MMR, according to the selection made by the user from the control panel.

For storage transmission, the image flow is as follows.

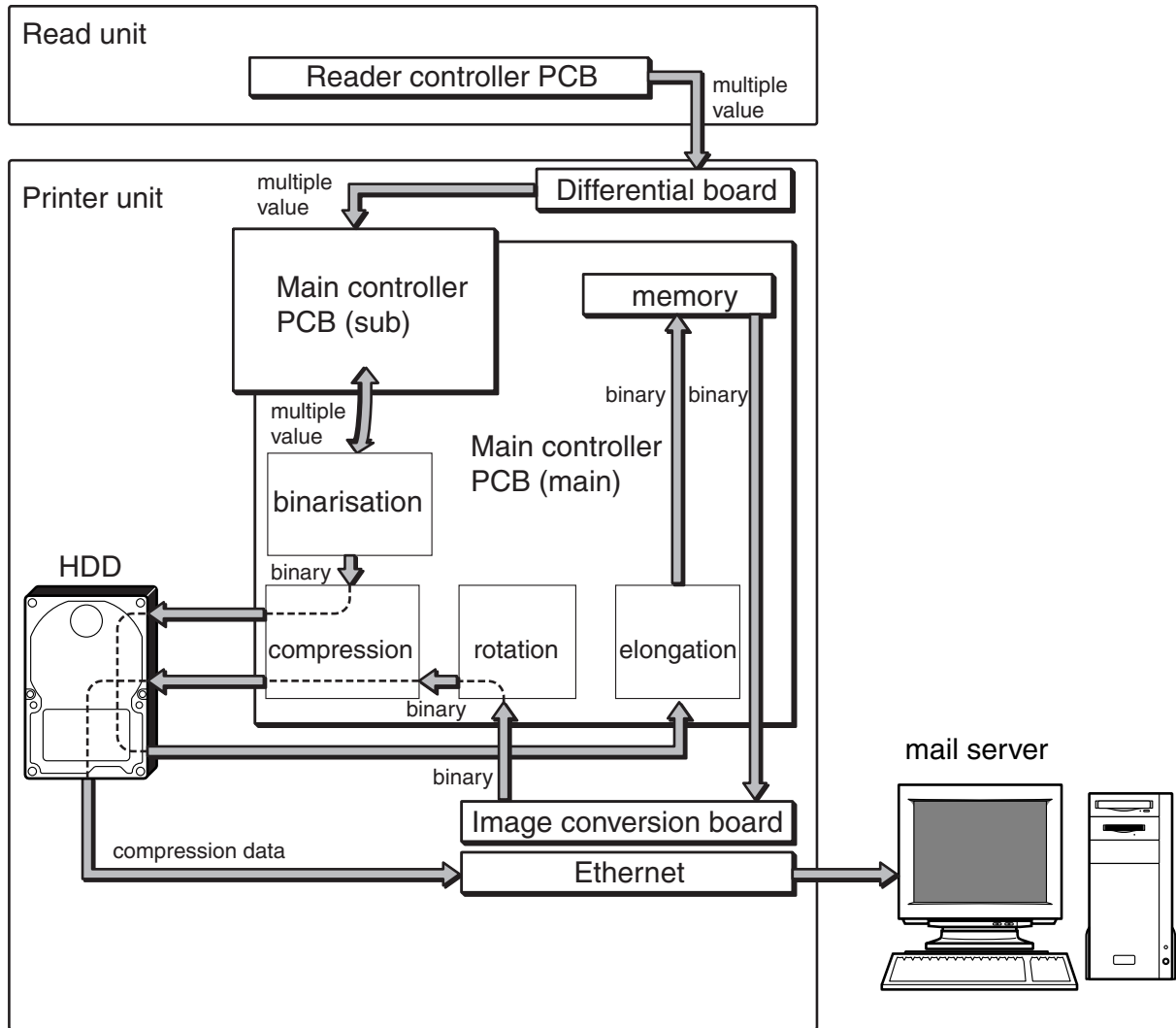

F08-202-03

For direct transmission, the data flow is as follows.

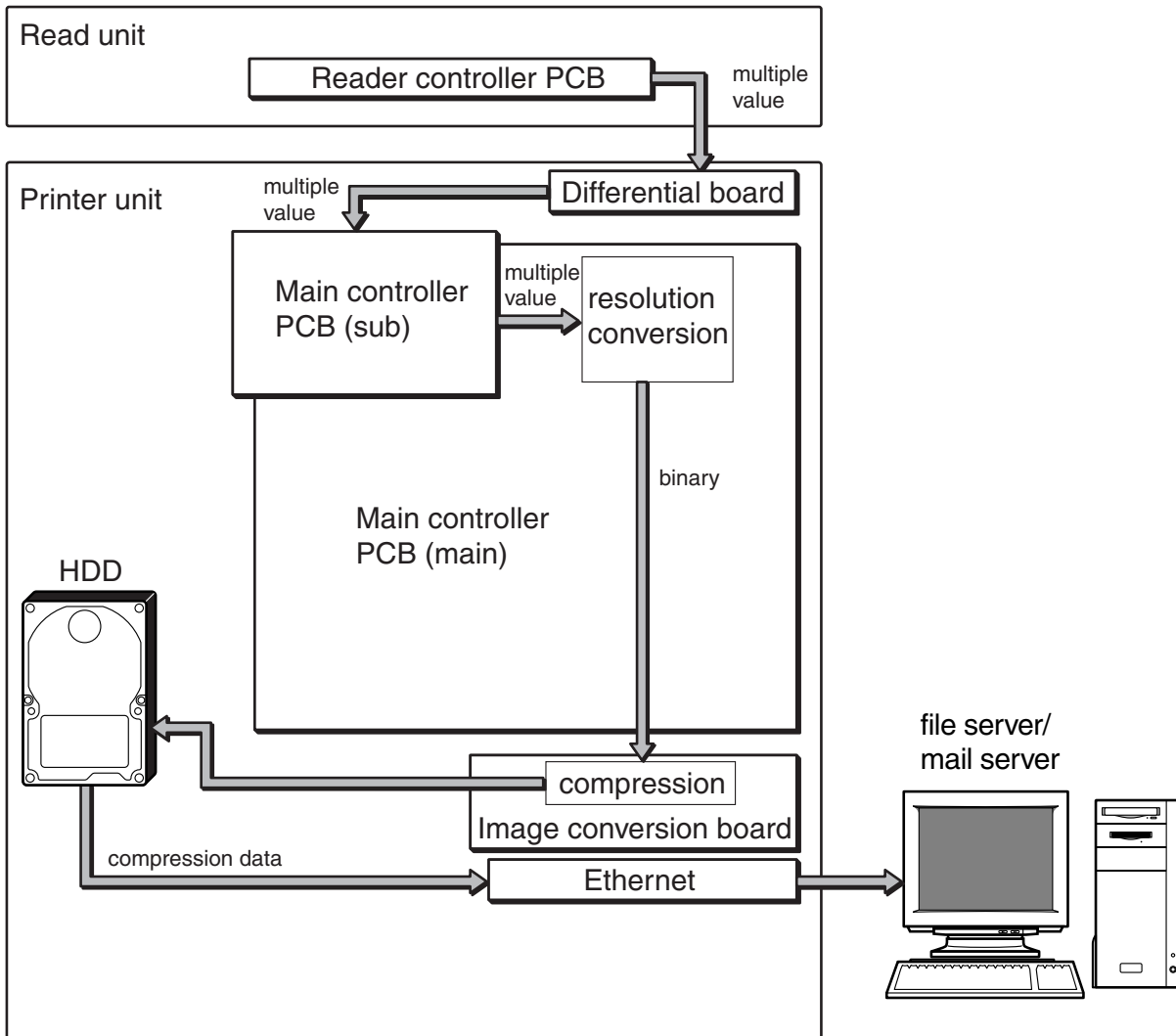

F08-202-04

3 Cautions when performing field service/Reference items

When performing service on this kit in the field, note the following cautions and reference items.

3.1 Cautions when installing

- Make sure that the resolution conversion board is installed.
- Image memory (SDRAM) is 768MB.
- When using Netware, the system must be changed. (iRC3200N does not need a system change.) For details, refer to the UFR installation procedures. (100V only)

3.2 Other cautions

In order to save the user's network settings and address settings, etc., if memory clear (MMI CLEA) or similar needs to be performed for service reasons, remember to print out the user data list (network) and address list from the user mode first. Also, before printing out the user's address lists, explain the reason to the user and obtain permission first.

CHAPTER 9

USB INTERFACE BOARD-A1

1 Product configuration

The product configuration of the kit is as follows.

- USB interface board A1

2 Specifications and functions

This kit is an optional board that adds the function of connecting the printer and the PC via local USB.

The main specifications are as follows.

2.1 Specifications

- USB Full Speed (equivalent to USB 1.1)
- Supported image data are as follows.
 - With UFR printer and scanner kit A1: GDI-UFR data only
 - GDI-UFR standard model: GDI-UFR data only
 - With PDL extension kit (LIPS) A1: GDI-UFR/ LIPS data
 - With Super G3FAX board M1: Bitmap data

3 Cautions when performing field service/Reference items

When performing service on this kit in the field, note the following cautions and reference items.

3.1 Cautions when installing

This kit is to be used together with the extension kit indicated in P10-2N. Note that it cannot be used on its own.

3.2 Other cautions

None.

CHAPTER 10

COLOR NETWORK MULTI-PDL PRINTER KIT-A1

1 Product Composition

This Kit consists of the following:

- UFR board
- PDL boot ROM
- User software CD-ROM
- Color Network ScanGear CD-ROM unit

2 Specifications and Functions

The major specifications and functions of this Kit are as follows:

2.1 Specifications

- Equipped with PCL 5C.
- Compatible with PostScript 3 (136 fonts; unknown fonts converted to Courier).
- Provides a data processing resolution of 600 dpi.
- Offers full-color mode/monochrome mode.
- Effective Print Area
2.5 mm in main scanning direction; 2.5 mm in sub scanning direction
- Supported Operating Systems
 - Windows 2000 Professional/Server/Advanced Server
 - Windows XP Home Edition/Professional
 - Windows 98/98SE/ME
 - Macintosh OS 7.x or alter

- Supported Paper Sizes
 - Default Sizes

Paper size	Unit	Dimensions	Effective print	Effective print area (area in mm ²)	Margin			
		(width × height) upper cell: in mm lower holder: in dots	area (width × height) upper cell: in mm lower cell: in dots		upper cell: in mm	lower cell: in dots	(left)	(upper)
A3		297.0 × 420.0	292.0 × 415.0	121,180	2.5	2.5	2.5	2.5
	600 DPI	7,014 × 9,920	6,894 × 9,800		60	60	60	60
A4		210.0 × 297.0	205.0 × 292.0	59,860	2.5	2.5	2.5	2.5
	600 DPI	4,960 × 7,014	4,840 × 6,894		60	60	60	60
A5		148.0 × 210.0	143.0 × 205.0	29,315	2.5	2.5	2.5	2.5
	600 DPI	3,496 × 4,960	3,376 × 4,840		60	60	60	60
B4 (JIS)		257.0 × 364.0	252.0 × 359.0	90,468	2.5	2.5	2.5	2.5
	600 DPI	6,070 × 8,598	5,950 × 8,478		60	60	60	60
B5 (JIS)		182.0 × 257.0	177.0 × 252.0	42,484	2.5	2.5	2.5	2.5
	600 DPI	4,298 × 6,070	4,178 × 5,950		60	60	60	60
Executive		184.2 × 266.7	179.2 × 261.7	44,718	2.5	2.5	2.5	2.5
	600 DPI	4,350 × 6,300	4,230 × 6,180		60	60	60	60
Legal		215.9 × 355.6	210.9 × 350.6	71,159.04	2.5	2.5	2.5	2.5
	600 DPI	5,100 × 8,400	4,980 × 8,280		60	60	60	60
Letter		215.9 × 279.4	210.9 × 274.4	55,469.46	2.5	2.5	2.5	2.5
	600 DPI	5,100 × 6,600	4,980 × 6,480		60	60	60	60
STATEMENT (US/UK/FIGS)		139.7 × 215.9	134.7 × 210.9	28,408	2.5	2.5	2.5	2.5
	600DPI	3,300 × 5,100	3,180 × 4,980		60	60	60	60
SRA3		320.0 × 450.0	306.0 × 445.0	140,175	7.5	7.5	2.5	2.5
	600DPI	7,558 × 10,628	7,438 × 10,508		180	180	60	60
12×18		304.8 × 457.2	299.8 × 452.2	135,569	2.5	2.5	2.5	2.5
	600DPI	7,200 × 10,800	7,080 × 10,680		60	60	60	60
C5 ISO (US/UK/FIGS)		162.0 × 229.0	89.7 × 199.8	17,922	2.5	2.5	2.5	2.5
	600DPI	3,826 × 5,408	2,120 × 4,720		60	60	60	60
COM 10 (US/UK/FIGS)		104.8 × 241.3	99.8 × 236.3	23,582	2.5	2.5	2.5	2.5
	600DPI	2,474 × 5,700	2,354 × 5,580		60	60	60	60
Monarch		98.4 × 190.5	93.4 × 185.5	17,325	2.5	2.5	2.5	2.5
	600DPI	4,500 × 2,324	4,380 × 2,204		60	60	60	60
B5 ISO		176.0 × 250.0	171.0 × 245.0	41,895	2.5	2.5	2.5	2.5
	600DPI	4,156 × 5,904	4,036 × 5,784		60	60	60	60

T10-201-01

– Non-Default Sizes

User-defined paper dimensions (area within parentheses in mm ² ; rounded to closest whole number)	
Minimum (1/10 [mm])	Maximum 1/10 [mm]
1,000 × 1,480 (14,800)	3,060 × 4,570 (139,842)

- The height and width will be in units of 1/10 mm (Japanese/UK English) or inches (US English).
 - The height must always be larger than or equal to the width (i.e., height ≥ width).
 - An inaccuracy can occur when rounding for dot conversion.
- **Area-Specific Paper Sizes**
In addition to default paper sizes (A4/LTR) and user-defined paper sizes, the printer driver supports area-specific paper sizes (e.g., Officio), and it handles these area-specific paper sizes as user-defined paper sizes, requiring the user to register them in advance of use. To do so, see the instructions on registering user-defined paper sizes for individual operating systems.
When an area-specific paper size is manually set up under [Form to Tray Assignment] of the driver UI, or if the size obtained by running dynamic configuration happens to be an area-specific paper size, the driver operates in the corresponding mode. After performing all associated internal operations, the driver runs a check of area-specific paper sizes stored as user defined paper sizes, and handles any matching paper as a default paper size (special paper ID) instead of as a user-defined paper size.
Moreover, the driver permits registration of multiple area-specific paper sizes, treating them as a separate paper group. The driver UI handles them using specifications designed for LTR paper, permitting the use of finisher functions, which were previously offered for user-defined paper sizes (except the use of the middle binding function). Although it will permit all settings, the printer unit may ignore some of the settings. (The printer driver will simply ignore them, not issuing conflicts.)

Paper		Dimensions	
		Feed direction	Width
Government Letter	G_LTR	203.0	267.0
Government LetterR	G_LGL	330.0	203.0
Foolscap	FLSP	330.0	216.0
Oficio	OFI	317.0	216.0
Folio	FOLIO	330.0	210.0
Ecuadorian Oficio	E_OFI	320.0	220.0
Argentine Oficio	A_OFI	340.0	220.0
Australian Foolscap	A_FLSP	337.0	206.0
Argentine Letter	A_LTR	220.0	280.0
Bolivian Oficio	B_OFI	355.0	216.0
Mexican Oficio	M_OFI	341.0	216.0

T10-201-02

2.2 New Functions

2.2.1 Flow of Image Data

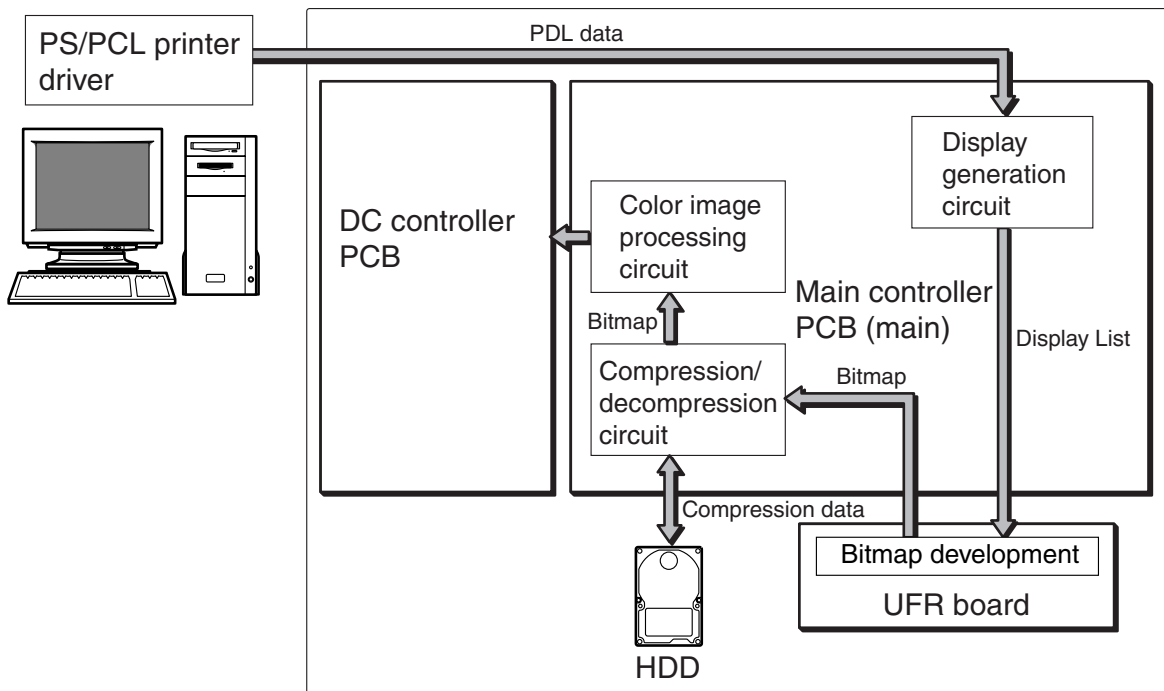

F10-202-01

<PCL>

- Gray Compensation

If R=G=B, determines whether or not to print objects in K monochrome (including text, graphics, images).

If gray compensation has been selected for an object (i.e., by enabling gray compensation), the object will be printed in K monochrome if R=G=B. If gray compensation has not been selected (i.e., by disabling gray compensation), the object will be printed in CMYK even when R=G=B.

- Halftone

Halftone may be selected for any object of text, graphics, or image.

- Save Toner

The amount of toner to be used may be reduced to save on its consumption.

- Super Smooth

The use of the Super Smooth Technology may be enabled or disabled. Use it for smoother reproduction of characters or lines drawn at angles.

- Gradation
Gradation smoothing may be enabled or disabled.
- Toner Density
For CMYK, the density of toner may be specified individually.

<PS>

New Functions

- Color Mode
A page may be printed in color or monochrome.

Monochrome

Use it to print a page in monochrome. If the PDL input is color data, it will be converted to gray data as part of PDL processing, turning out a monochrome page. The charging will be for a monochrome print.

Full Color

Use it to print a page in full color. However, gray data will print as a monochrome print. Moreover, color data will print as a monochrome page if it consists of objects for which gray compensation has been selected and if it is R=G=B. Otherwise, printing will be of a color page even if all its objects are monochrome. The charging will be for a color print.

Auto Switchover

If all objects of a page are gray data, internal identification will turn on monochrome operations ([print mode]); otherwise, full color operations will be turned on.

- RGB Source Profile
This setting allows you to define the characteristics RGB profile (color data represented using the RGB (Red, Green, and Blue) color model) used when printing color images or graphics in a document. This ensures that the machine uses the most appropriate color conversion when printing color documents using the CMYK color model.
- Rendering Style
- CMYK Simulation Profile
This setting allows you to change the simulation target for the current job. When the machine processes the job, the simulation target selected in CMYK Simulation Profile is applied before the job is printed using the CMYK (Cyan, Magenta, Yellow, and Key (black)) color model.

- **Matching Method**
This setting allows you to select a default color rendering dictionary (CRD) to be used when printing RGB images and text. A CRD is used by the color management system to ensure the best possible translation when the machine converts data between color models. This machine includes several CRDs that provide different color rendering styles.
- **Pure Black Text/Graphics**
- **Black Overprint**
When printing black text in combination with a color background or graphics, the text can be printed in one of two ways: either as part of the color background, or not. This setting allows you to choose a specific way to print black text for such a job.
- **Output Profile**
This setting allows you to define the Output Profile. It is applied to all data in the print job, so make sure the selected profile is right for your job.
- **Brightness**
This setting adjusts the brightness of the overall image.
- **Half Tone**
This setting enables you to apply the following patterns to Text, Graphics, and Image data.
Halftoning is used to print each process color at a different intensity, allowing millions of different colors to be reproduced using only the four process colors. Depending on the required intensity of a given color, toner is placed on paper in dots of different sizes. The grid of dots used for each toner color is called a screen. Halftone screens are aligned to unique angles designed to eliminate interference patterns called moire (a shimmering, wavy effect) that can arise with halftoning.
- **Save Toner**
The amount of toner to be used may be reduced to save on its consumption.
- **Super Smooth**
The use of the Super Smooth Technology may be enabled or disabled. Use it for smoother reproduction of characters or lines drawn at angles.
- **Gradation**
Gradation smoothing may be enabled or disabled.

2.3 Points to Note About Servicing in the Field (supplementary information)

Keep the following in mind when servicing the Kit in the field:

- Be sure that the machine's network settings have properly been made.
- Be sure that the Extension button is indicated on the machine's control panel.
- Be sure that ScanGear (printer driver) has been installed on the PC.
- If the model is equipped with a reader unit, be sure to execute 'auto gradation correction' using the machine's user mode.
- In the case of the printer model, perform calibration using the CC-100. (As a rule, it is done by the user.)
- At times, the paper sizes and margin sizes may be larger or smaller than the selected or required sizes, owing to inaccuracies in computations performed by the system, application, or driver or because of any differences in accuracy of feed, temperature, or humidity as noted by the printer engine.

CHAPTER 11

iR SECURITY KIT-A1P/A1U

1 Product Composition

This Kit consists of the following:

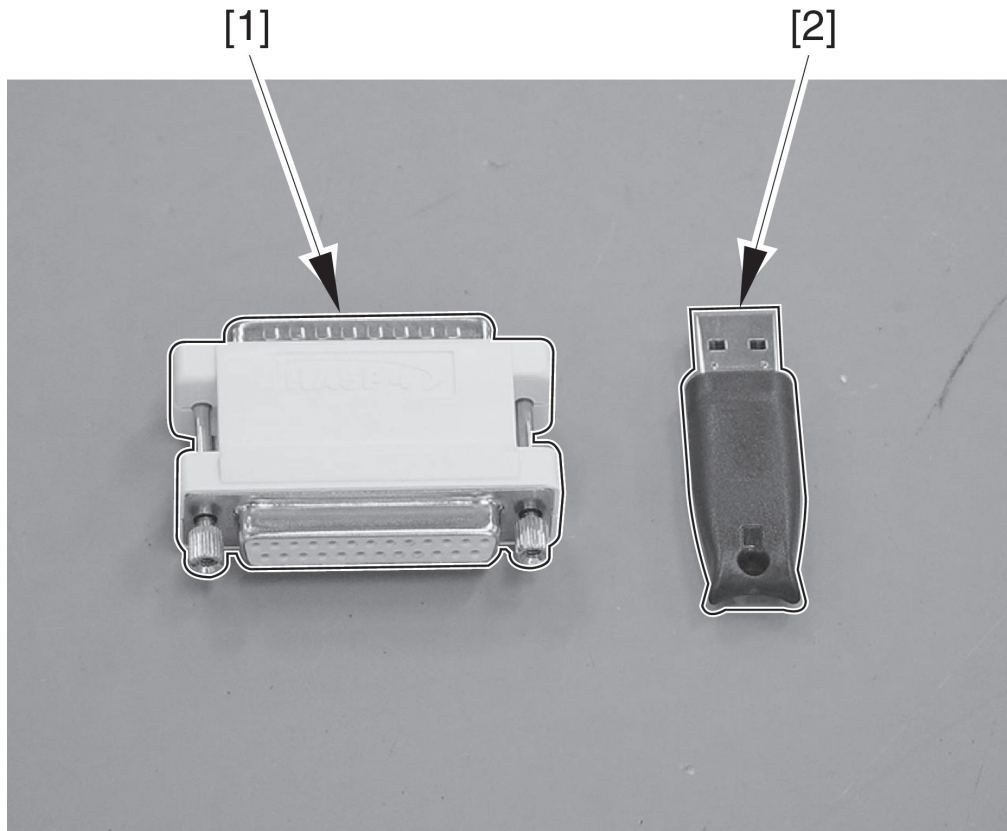

F11-100-01

- Protect key device (parallel; for A1P) [1] 1 pc.
- Protect key device (USB; for AU) [2] 1 pc.
- iR Series security system setup tool CD-ROM 1 pc.
- User's Guide 1 pc.
- Serial No. label 1 pc.

2 Specifications and Functions

2.1 Outline

By connecting the printer unit to a PC over a network or a parallel cable and making use of the Kit's protect key device and iR Series security system setup tool, you can draw upon the printer unit's security functions (optional).

For details of installation, see the Installation Procedure.

2.2 Specifications

- Supported Operating Systems
Windows 95/98/NT/2000/XP
(for USB, Windows 95 and NT are not supported)

2.3 Security Functions

Using the Kit, if you enable the security functions, the following 2 items (as selected) will be added to the system settings of user mode:

- turning on/off the function of completely initializing the hard disk
- turning on/off the function of indicating the job history

To indicate these functions in user mode, you will need to set them up in service mode (in the case of the following, in level 2 service mode: iR C3200/C3200S/C3200N, S3200, CLC3200, imageRUNER C3200).

For functions and how to indicate these items, see the following:

• Turning On/Off the Function to Completely Initialize the Hard Disk

<Function>

Turn it on or off depending on whether you want to write random data (i.e., 0s) over file data on the hard disk so as to fully reset the data on the hard disk at such times as logically removing files (when control information data is removed).

<Item in Service Mode>

COPIER>Option>USER>HDCR-DSP

<Scope and Operation>

0: do not indicate in user mode/do not delete data (default)

1: indicate in user mode/write '0' data once

2: indicate in user mode/write random data once

3: indicate in user mode/write random data 3 times

Change the setting to any from 1 through 3.



A higher setting will increase the security of data on the hard disk by so much.

- Turing On/Off the Function to Indicate the Job History

<Function>

Use it to specify whether or not to indicate the history of making copies/prints or sending/receiving faxes.

<Item in Service Mode>

COPIER>Option>USER>LGSW-DSP

<Scope and Operation>

0: do not indicate in user mode (default)

1: indicate in user mode

Change the setting from '0' to '1'.

3 Points to Note About Servicing in the Field (reference)

Keep the following in mind when servicing the Kit in the field:

3.1 Installation

To prevent damaging the protect key device by static charges, be sure to observe the following:

- Before starting the installation work, put on an anti-static wrist strap. If there is no grounding facility, connect the grounding wire of the strap to the frame of the machine to which you are installing the Kit.
- Unless you are using it, keep the protect key device in a conducting bag. Take it out of the bag only immediately before use.
- When handling the protect key device, avoid touching its connector terminal.

3.2 Other Points to Note

- Storing the Protect Key Device/CD-ROM After Use

You will need the protect key device and iR series security system setup tool CD-ROM if the security functions turn invalid, as when service mode has been used wrongly. Advise the user to store them properly so that they will be on hand when needed.

In particular, keep in mind that the protect key device may be used only for the printer unit it has once been used for. Advise the user to keep it in a conducting bag and store it in a safe place. If it is lost or damaged by static charges, the security functions cannot be set up for a second time.

Troubleshooting

SERVICE MANUAL

Contents

CHAPTER 1 MAINTENANCE AND INSPECTION

1 Maintenance and Inspection	1-1	1.2.3 Printer Unit	1-3
1.1 Periodically Replaced Parts	1-1	1.2.4 Side Paper Deck-P1	1-5
1.1.1 Reader Unit/Color Image Reader-C1	1-1	1.2.5 2-Cassette Pedestal-X1	1-6
1.1.2 Printer Unit	1-1	1.2.6 Plain Pedestal-C1	1-6
1.1.3 Side Paper Deck-P1	1-1	1.3 Scheduled Servicing Basic Procedure	1-7
1.1.4 2-Cassette Pedestal-X1	1-1	1.4 Scheduled Servicing	1-8
1.1.5 Plain Pedestal-C1	1-1	1.4.1 Reader Unit/Color Image Reader-C1	1-8
1.2 Durables and Consumables	1-2	1.4.2 Printer Unit	1-9
1.2.1 Find Out When to Replace	1-2	1.5 Points to Note About Scheduled Servicing	1-10
1.2.2 Reader Unit/Color Image Reader-C1	1-2		

CHAPTER 2 STANDARDS AND ADJUSTMENTS

1 Image Adjustments	2-1	3 Laser Exposure System	2-12
1.1 Standards for Image Position	2-1	3.1 After Replacing the Laser Unit	2-12
1.2 Checking the Image Position	2-2	4 Image Formation System	2-13
1.3 Adjusting the Left/Right Margin	2-3	4.1 After Replacing the Drum Unit	2-13
1.3.1 Cassette	2-3	4.2 After Replacing the Transfer Unit	2-13
1.3.2 Manual Feed Tray	2-7	4.3 After Replacing the Pattern Reading Unit	2-13
1.3.3 Side Paper Deck	2-7	5 Fixing System	2-14
1.3.4 Duplex Unit	2-8	5.1 After Disassembling the Fixing Unit	2-14
1.4 Adjusting the Image Leading Edge Margin	2-9	6 Electrical Parts	2-15
1.5 Adjusting the Left/Right Non- Image Width	2-9	6.1 When Replacing the Reader Controller PCB	2-15
1.6 Adjusting the Leading Edge Non-Image Width	2-10	6.2 When Replacing the DC Controller PCB	2-16
2 Optical System	2-11	6.3 When Replacing the Main Controller PCB	2-16
2.1 After Replacing the Scanning Lamp	2-11	6.4 When Replacing the SRAM PCB	2-16
2.2 After Replacing the Copyboard Glass	2-11		
2.3 After Replacing the CCD Unit	2-11		

6.5	When Replacing the HDD	2-16	7.4	When Replacing the Fixing/ Feeder Unit Open/Closed Sensor	2-17
6.6	When Replacing the Power Supply PCB	2-16	8	Side Paper Deck	2-18
7	Pickup/Feeding	2-17	8.1	Adjusting the Paper Level Indicator	2-18
7.1	Adjusting the Horizontal Registration When Replacing the Pickup Cassette	2-17	8.2	Adjusting the Roll Support Plate	2-18
7.2	Attaching the Plastic Film for the Face-Down Delivery Guide Unit	2-17	8.3	Mounting the Deck Pickup Roller	2-18
7.3	Adjusting the Horizontal Registration When Replacing the Duplex Unit	2-17	8.4	Adjusting the Deck Separation Roller Pressure	2-18
			8.5	Adjusting the Height of the Side Clip	2-18
			8.6	Routing the Lifter Cable	2-18

CHAPTER 3 CORRECTING FAULTY IMAGES

1	Making Initial Checks	3-1	3.1	The output is completely blank.	3-17
1.1	Site Environment	3-1	3.2	The output is completely black.	3-17
1.2	Checking the Paper	3-1	3.3	The output is too light.	3-17
1.3	Checking the Placement of Paper	3-1	3.4	The output is too dark/has fogging.	3-19
1.4	Checking the Durables	3-1	3.5	The output is uneven in density/ color.	3-20
1.5	Checking the Periodically Replaced Parts	3-1	3.6	The output is blurry, smeared, or fuzzy.	3-23
1.6	Checking the Units and Functional Blocks	3-2	3.7	The output has transfer faults/lines.	3-24
1.7	Others	3-4	3.8	The output is soiled/has lines.	3-27
2	Test Print	3-5	3.9	The output has a residual image/ghost.	3-29
2.1	Test Print TYPE	3-5	3.10	The output has color displacement.	3-30
2.2	Selecting a Test Print TYPE	3-5	3.11	The output has poor color reproduction.	3-31
2.3	16 Gradations (TYPE=4)	3-6	3.12	The output has smears/traces. (rub-off)	3-31
2.4	Full Halftone (TYPE=5)	3-7	4	Feed Faults	3-32
2.5	Grid (TYPE=6)	3-8	4.1	Multiple Feed	3-32
2.6	MCYBk Horizontal Stripe (TYPE=10)	3-9			
2.7	64 Gradations (TYPE=12)	3-10			
2.8	Full Color 16 Gradations (TYPE=14)	3-11			
3	Image Fault Case Studies	3-13			
A.	Image Fault Case Samples	3-13			
B.	Image Fault Case Samples	3-15			

4.2	Skew Movement	3-32	7.3.1	Reader Unit	3-41
4.3	Bend/Tear	3-32	7.3.2	Printer Unit	3-41
4.4	Wrinkle	3-32	7.4	Sensors	3-42
4.5	Wave/Curl	3-33	7.4.1	Reader Unit	3-42
5	Operating Faults	3-34	7.4.2	Printer Unit	3-42
5.1	The machine fails to go ON.	3-34	7.5	Switches	3-45
5.2	Control Panel-Related	3-34	7.5.1	Reader Unit	3-45
5.3	Malfunction/Wrong Detection	3-34	7.5.2	Printer Unit	3-45
5.4	Abnormal Noise	3-34	7.6	Lamps, Heaters, and Others	3-46
6	Jams	3-35	7.6.1	Reader Unit	3-46
6.1	Pickup Unit	3-35	7.6.2	Printer Unit	3-46
6.2	Registration Unit	3-36	7.7	PCBs	3-48
6.3	Fixing Feeder Unit	3-36	7.7.1	Reader Unit	3-48
6.4	Delivery Vertical Path Unit	3-37	7.7.2	Printer Unit	3-48
6.5	Duplex Unit	3-37	7.8	2-Cassette Pedestal-X1	3-51
7	Arrangement and Functions of Electrical Parts	3-38	7.9	Plain Pedestal-C1	3-53
7.1	Clutches and Solenoid	3-38	8	Variable Resistors (VR), Light- Emitting Diodes (LED), and Check Pins by PCB	3-54
7.1.1	Reader Unit	3-38	8.1	Main Controller PCB (main) ...	3-55
7.1.2	Printer Unit	3-38	8.2	Main Controller PCB (sub)	3-56
7.2	Motor	3-39	8.3	Reader Controller PCB	3-57
7.2.1	Reader Unit	3-39	8.4	Inverter PCB	3-58
7.2.2	Printer Unit	3-39	8.5	Differential PCB	3-58
7.3	Fans	3-41			

CHAPTER 4 SELF DIAGNOSIS

1	Error Code	4-1	5	Error Code Related to the Finisher-M1	4-18
2	Error Code Related to the Reader Unit	4-2	6	Error Code Related to the Options Board	4-20
3	Error Code Related to the Printer Unit	4-3	7	Error Code Related to the DADF-K1	4-21
4	Error Code Related to the Finisher- N1/Saddle Finisher-N2	4-11	8	Error Code Related to the Cassette Pedestal	4-22
4.1	Finisher Unit	4-11			
4.2	Saddle Unit	4-14			

CHAPTER 5 SERVICE MODE

1 Overview	5-1	5.1 COPIER	5-53
1.1 Service mode screen configuration	5-1	5.2 FEEDER	5-65
1.2 Entering or selecting service modes	5-3	6 ADJUST (adjustment mode): Level 2	5-69
1.3 Exiting service modes	5-4	7 FUNCTION (operation/inspection mode): Level 1	5-72
1.4 Service mode backup	5-5	7.1 COPIER	5-72
1.5 Basic operation	5-6	7.2 FEEDER	5-87
1.5.1 Initial screen	5-6	8 FUNCTION (operation/inspection mode): Level 2	5-88
1.5.2 Main/intermediate item screen	5-6	9 OPTION (mechanical specifications setting mode): Level 1	5-89
1.5.3 Sub-item screen	5-7	9.1 COPIER	5-89
2 DISPLAY (status display mode): Level 1	5-8	9.2 SORTER	5-107
2.1 COPIER	5-8	9.3 BOARD	5-107
2.2 FEEDER	5-25	10 OPTION (mechanical specifications setting mode): Level 2	5-108
3 DISPLAY (status display mode): Level 2	5-26	11 TEST (test print mode)	5-116
4 I/O (display mode)	5-28	12 COUNTER (counter mode)	5-121
5 ADJUST (adjustment mode): Level 1	5-53		

CHAPTER 6 UPGRADING

1 Outline of Upgrading Work	6-1	3 Downloading Firmware	6-29
1.1 Outline	6-1	3.1 Downloading the System Software	6-29
1.1.1 Composition of Firmware	6-1	3.1.1 Outline	6-29
1.1.2 Outline of the Service Support Tool	6-3	3.1.2 Downloading Procedure	6-31
1.1.3 Network Interface of the Machine with the SST in Use	6-6	3.2 Downloading the Language/ RUI Files	6-37
1.2 Preparing for the Work	6-10	3.2.1 Outline	6-37
1.2.1 Registering the Firmware	6-10	3.2.2 Downloading Procedure	6-39
1.2.2 Making Connections	6-14	3.3 Downloading Boot ROM Files	6-44
2 Formatting the HDD	6-20	3.3.1 Outline	6-44
2.1 Formatting All Partitions	6-20	3.3.2 Downloading Procedure	6-45
2.2 Formatting Selected Partitions	6-21	3.4 Downloading DC Controller/ Reader Controller Files	6-51
2.3 Formatting the Partitions	6-23	3.4.1 Outline	6-51
		3.4.2 Downloading Procedure	6-52

3.5 Downloading the G3Fax Files	6-59	4 Uploading/Downloading Backup Data	6-66
3.5.1 Outline	6-59	4.1 Outline	6-66
3.5.2 Downloading Procedure	6-60	4.2 Uploading Procedure	6-68
		4.3 Downloading Procedure	6-73

APPENDIX

1 General Timing Chart	A-1	E. Pattern Reader Circuit Diagram	A-25
1.1 Sequence of Operations (DADF, reader unit)	A-1	F. Laser Exposure System/Development System Circuit Diagram	A-26
1.2 Sequence of Operations (printer unit)	A-2	G. Pickup System Circuit Diagram	A-27
2 Signal Names and Notations	A-3	H. High-Voltage Circuit Diagram	A-28
2.1 Signal Names	A-3	I. Fixing System Circuit Diagram	A-29
3 General Circuit Diagram	A-19	J. Feeder System Circuit Diagram	A-30
3.1 Names of Electrical Parts	A-19	4 Special Tools	A-31
A. Reader Unit Circuit Diagram	A-21	5 Solvents and Oils	A-33
B. Accessories Circuit Diagram	A-22		
C. Power Supply Circuit Diagram	A-23		
D. Main Controller Circuit Diagram	A-24		

CHAPTER 1

MAINTENANCE AND INSPECTION

1 Maintenance and Inspection

1.1 Periodically Replaced Parts

Some parts of the machine must be periodically replaced to ensure a specific level of product performance (i.e., they may not show wear but can significantly affect the machine performance once they fail). If possible, schedule any periodical replacement so that it coincides with scheduled servicing.



The guide to periodical replacement is subject to change according to the site of installation and habits of use.

1.1.1 Reader Unit/Color Image Reader-C1

The reader unit/Color Image Reader-C1 does not have parts that require periodical replacement.

1.1.2 Printer Unit

The printer unit does not have parts that require periodical replacement.

1.1.3 Side Paper Deck-P1

The Side Paper Deck-P1 does not have parts that require periodical replacement.

1.1.4 2-Cassette Pedestal-X1

The 2-Cassette Pedestal-X1 does not have parts that require periodical replacement.

1.1.5 Plain Pedestal-C1

The Plain Pedestal-C1 does not have parts that require periodical replacement.

1.2 Durables and Consumables

Some parts of the machine may require replacement once or more over the life of the product because of deterioration or damage. Replace them as needed by referring to the guide.

1.2.1 Find Out When to Replace

Use the following service mode to find out when it is best to replace a specific durable part.

- Copier
COPIER>COUNTER>DRBL-1
- Option
COPIER>COUNTER>DRBL-2

1.2.2 Reader Unit/Color Image Reader-C1

The reader unit/Color Image Reader-C1 does not have parts that are designated as “durables.”

1.2.3 Printer Unit

As of October 2002

No.	Parts name	Parts No.	Q'ty	Life (copies)	Remarks
[1]	Waste toner container	FG6-8992	1	60,000	
[2]	Secondary transfer external roller (100V)	FG6-9691	1	300,000	actual copies made
[2]	Secondary transfer external roller (120/230V)	FG6-8997	1	300,000	actual copies made
[3]	Transfer cleaning unit	FG6-8989	1	100,000	
[4]	Fixing roller	FB6-3641	1	100,000	actual copies made
[5]	Pressure roller	FB6-3653	1	100,000	actual copies made
[6]	Transfer belt	FB6-2930	1	300,000	actual copies made
[7]	Drive roller	FB6-2931	1	300,000	actual copies made
[8]	Primary transfer roller	RB2-6870	4	300,000	
[9]	Secondary transfer internal roller	FB6-2934	1	300,000	actual copies made
[10]	Feed roller (for each cassette holder)	FB6-3407	2	250,000	actual copies made
[11]	Separation roller (for each cassette holder)	FB6-3407	2	250,000	actual copies made
[12]	Separation roller (manual feeder)	FB1-8581	1	120,000	actual copies made
[13]	Separation roller (manual feeder)	FB5-0873	1	120,000	actual copies made
[14]	Fixing upper frame unit	FG6-9645	1	100,000	
[15]	Fixing unit (100V)	FG6-9066	1	200,000	
[15]	Fixing unit (120V)	FG6-9069	1	200,000	
[15]	Fixing unit (230V)	FG6-9070	1	200,000	
[16]	Pressure roller bearing	XG9-0478	2	100,000	actual copies made

T01-102-01

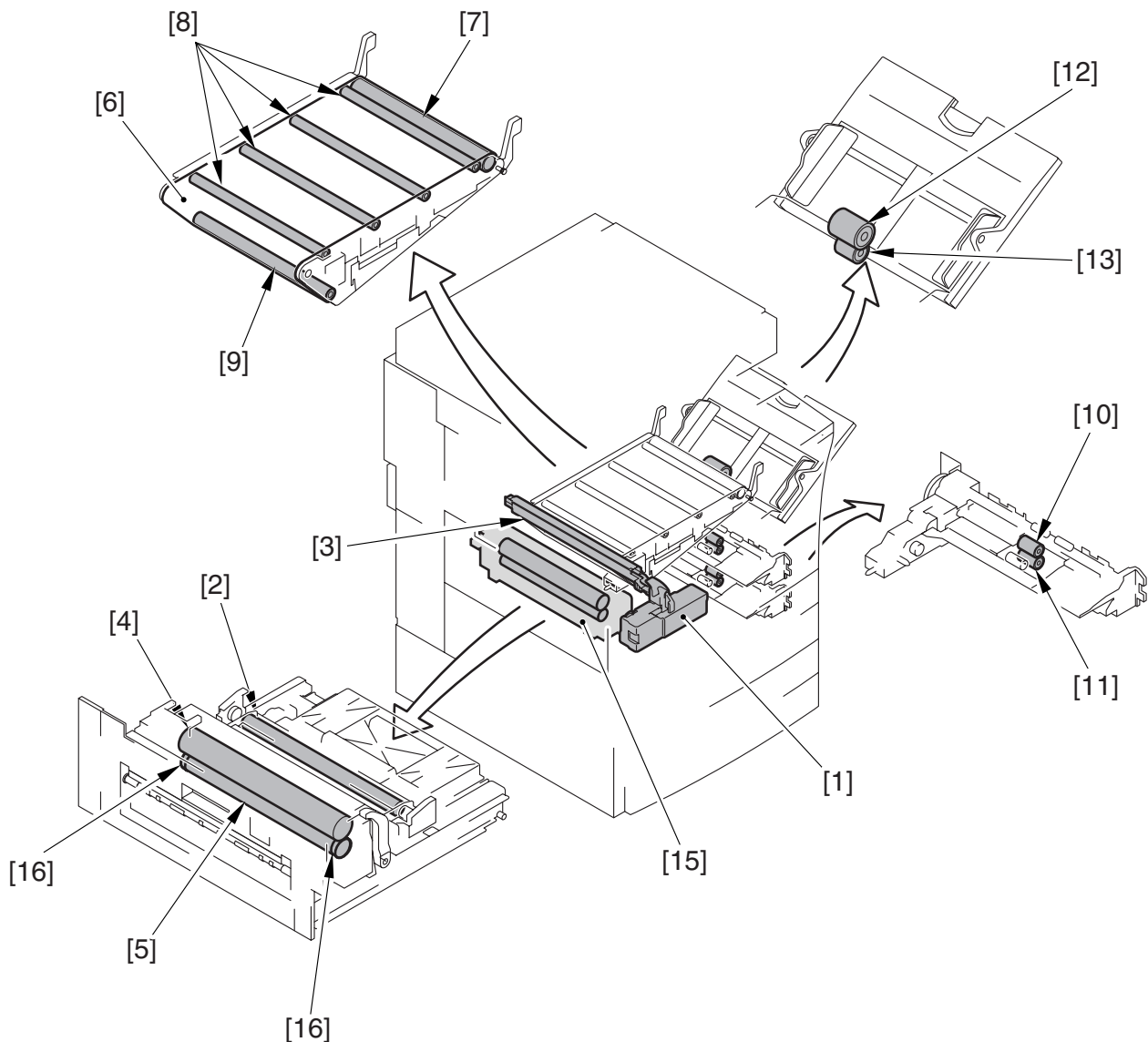

F01-102-01

1.2.4 Side Paper Deck-P1

As of October 2002

No.	Parts name	Parts No.	Q'ty	Life (copies)	Remarks
[1]	Pickup roller (front)	FF5-7829	1	250,000	actual copies made
[2]	Pickup roller (rear)	FF5-7830	1	250,000	actual copies made
[3]	Feed roller	FF5-7541	1	250,000	actual copies made
[4]	Separation roller	FB2-7777	1	250,000	actual copies made

T01-102-02

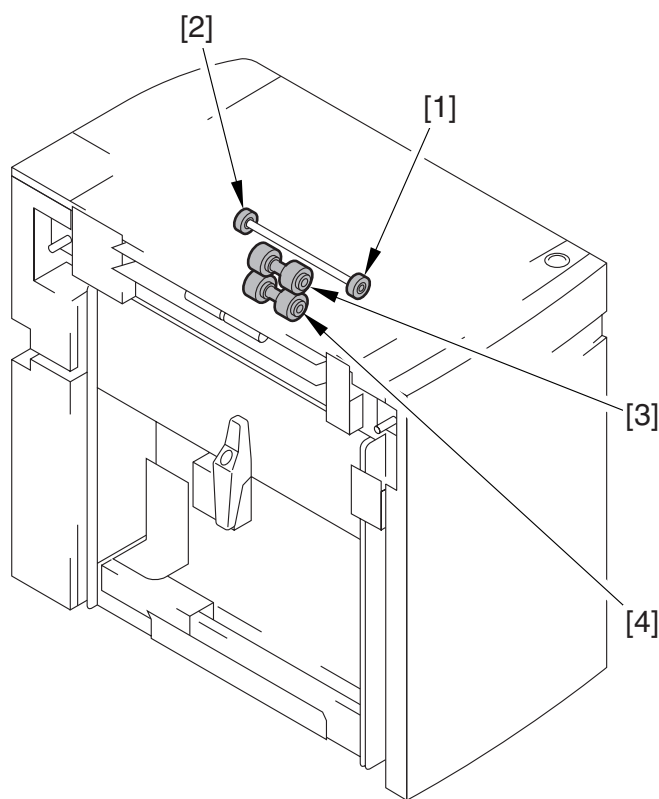

F01-102-02

1.2.5 2-Cassette Pedestal-X1

As of October 2002

No.	Parts name	Parts No.	Q'ty	Life (copies)	Remarks
[1]	Feed roller	FB6-3407	2	250,000	actual copies made
[2]	Separation roller	FB6-3407	2	250,000	actual copies made

T01-102-03

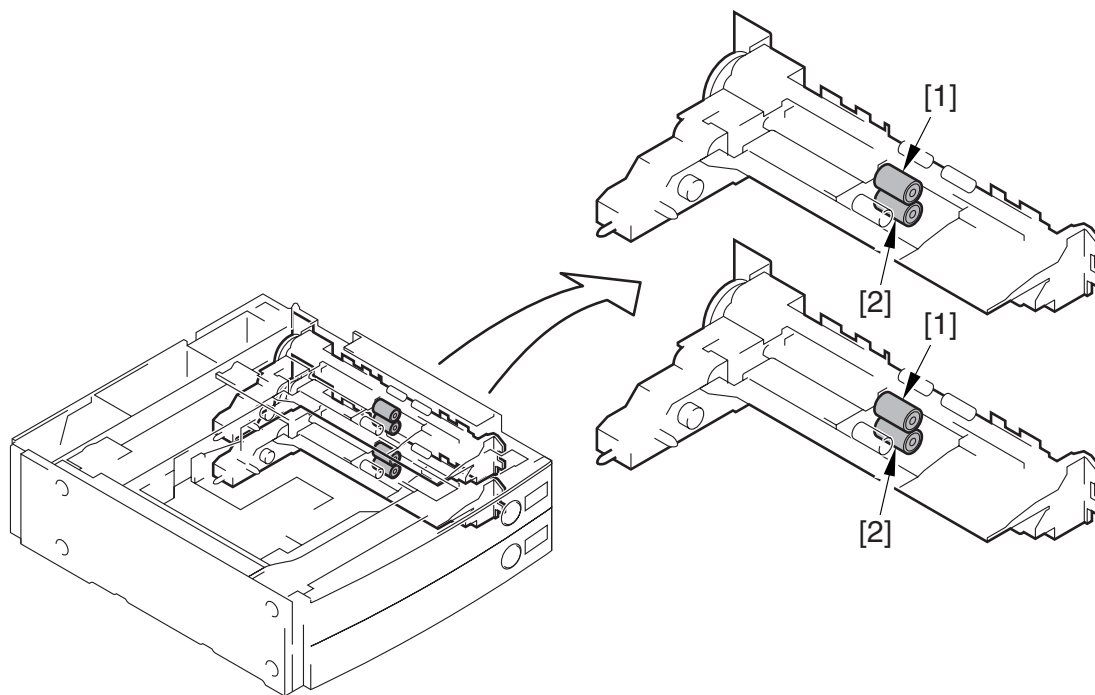

F01-102-03

1.2.6 Plain Pedestal-C1

The Plain Pedestal-C1 does not have parts that are designated as “durables.”

1.3 Scheduled Servicing Basic Procedure



-
1. As a rule, provide scheduled servicing every 40,000 prints.
 2. Before paying a scheduled visit, check the Service Record, and take any parts likely to need replacement.
 3. If the machine's power plug remains connected to a wall outlet for a long time in a site where there is much dust, moisture, or oil smoke, it can collect these elements and trigger insulation failure or fires. Be sure to disconnect the power plug periodically and clean the plug and the area around it with a dry cloth.
-

As of October 2002

Steps

1. Report to the person in charge. Check the general condition.
2. Record the counter reading. Check the faulty prints.
3. Make test prints.
 - (1) check the image density against standards;
 - (2) check for soiling in the white background;
 - (3) check the clarity of characters;
 - (4) check the margin;
 - (5) check the fixing; check for poor registration and soiling on the back.

Standards on margin (single-sided) leading edge: 2.5mm \pm 1.5mm,
trailing edge: 2.5mm \pm 1.5mm, left: 2.0mm \pm 1.5mm
4. Optical Assembly

Use a blower brush; if dirt cannot be removed, use alcohol:

 - (1) No. 1, 2, 3 mirror; (2) dust-proofing glass; (3) original reflecting plate;
 - (4) standard white plate.
5. Optical Path
 - (1) Scanner Cable

Check the cable for tension; as needed, make adjustments.
 - (2) Cable Rail

Clean the slides, and lubricate with silicone oil (FY9-6011).
6. Waste Toner Collecting Container

If the waste toner collecting container is more than half full, dispose of the toner in a plastic bag; or, replace the toner collecting container itself.



-
1. Be sure to observe all rules and regulations of the governing community when disposing of waste toner.
 2. Do not dispose of waste toner into fire. (It may explode, causing a significant hazard.)
-

7. Clean the copyboard glass and the reader glass.
8. Make test copies.
9. Make sample copies.

10. Check the operation of the leakage breaker.

With the power switch at 'ON', press the test switch of the leakage breaker to see that the breaker operates normally (i.e., the lever goes 'OFF' to shut off the power).

If the breaker fails to operate normally, replace it, and make a check once again.

Resetting:

After making a check, shift the power switch to 'OFF', lever to 'ON', and then the power switch to 'ON'.

11. Put the sample copies into order, and clean up the area around the machine.

12. Record the most recent counter reading.

13. Fill out the Service Record, and report to the person in charge.

Be sure to indicate the results of the check you have made on the leakage breaker.

1.4 Scheduled Servicing



Do not use solvents or oils that are not indicated herein.

1.4.1 Reader Unit/Color Image Reader-C1

Δ: clean ●: replace ×: lubricate □: adjust ⊙: inspect

Unit name	Location	Cleaning	Remarks
Optical assembly	Scanner cable	⊙	if dirt is appreciable
Optical path	Scanner rail	×	if dirt is appreciable
	Copyboard glass	Δ	if dirt is appreciable
	No. 1 through No. 3 mirrors	Δ	if dirt is appreciable
	Original reflecting plate	Δ	if dirt is appreciable
	Original size sensor	Δ	if dirt is appreciable
	Lens	Δ	if dirt is appreciable

T01-104-01

1.4.2 Printer Unit

△: clean ●: replace ×: lubricate □: adjust ⊙: inspect

Unit name	Location	Maintenance intervals			Remarks
		every 40,000	150,000	Other	
Delivery unit	Internal delivery roller			△	if dirt is appreciable
	External delivery roller			△	if dirt is appreciable
Duplex feed unit	Duplex roller 1			△	if dirt is appreciable
	Duplex roller 2			△	if dirt is appreciable
	Duplex roller 3			△	if dirt is appreciable
	Duplex roller 4			△	if dirt is appreciable
Delivery vertical path unit	Reversing roller	△			
	Face-down delivery roller 1	△			
	Face-down delivery roller 2	△			
Fixing unit	Fixing inlet guide			△	if dirt is appreciable
	Fixing inlet roll			△	if dirt is appreciable
	Delivery upper guide			△	if dirt is appreciable
	Delivery lower guide			△	if dirt is appreciable
Manual feed registration unit	Pre-registration roller			△	if dirt is appreciable
	Registration upper roller			△	if dirt is appreciable
	Registration lower roller			△	if dirt is appreciable
	Pickup vertical path roller			△	if dirt is appreciable
Intermediate transfer unit	Drive roller		△		or, when replacing the intermediate transfer belt
	Tension roller		△		or, when replacing the intermediate transfer belt
	Secondary transfer internal roller		△		or, when replacing the intermediate transfer belt
	Internal transfer belt (inside)		△		or, when replacing the intermediate transfer belt
Secondary transfer unit	Secondary transfer rear guide			△	if dirt is appreciable

T01-104-02

The above values are estimates only and are subject to change based on future data.

1.5 Points to Note About Scheduled Servicing

Unless otherwise specifically mentioned, use lint-free paper and alcohol for cleaning.



-
- If you used solvent for cleaning, be sure that the solvent has completely dried before mounting the part back to the machine.
 - Unless specifically mentioned, do not use a wet (moist) cloth for cleaning.
 - See to it that scheduled servicing and replacement are conducted as indicated.
-

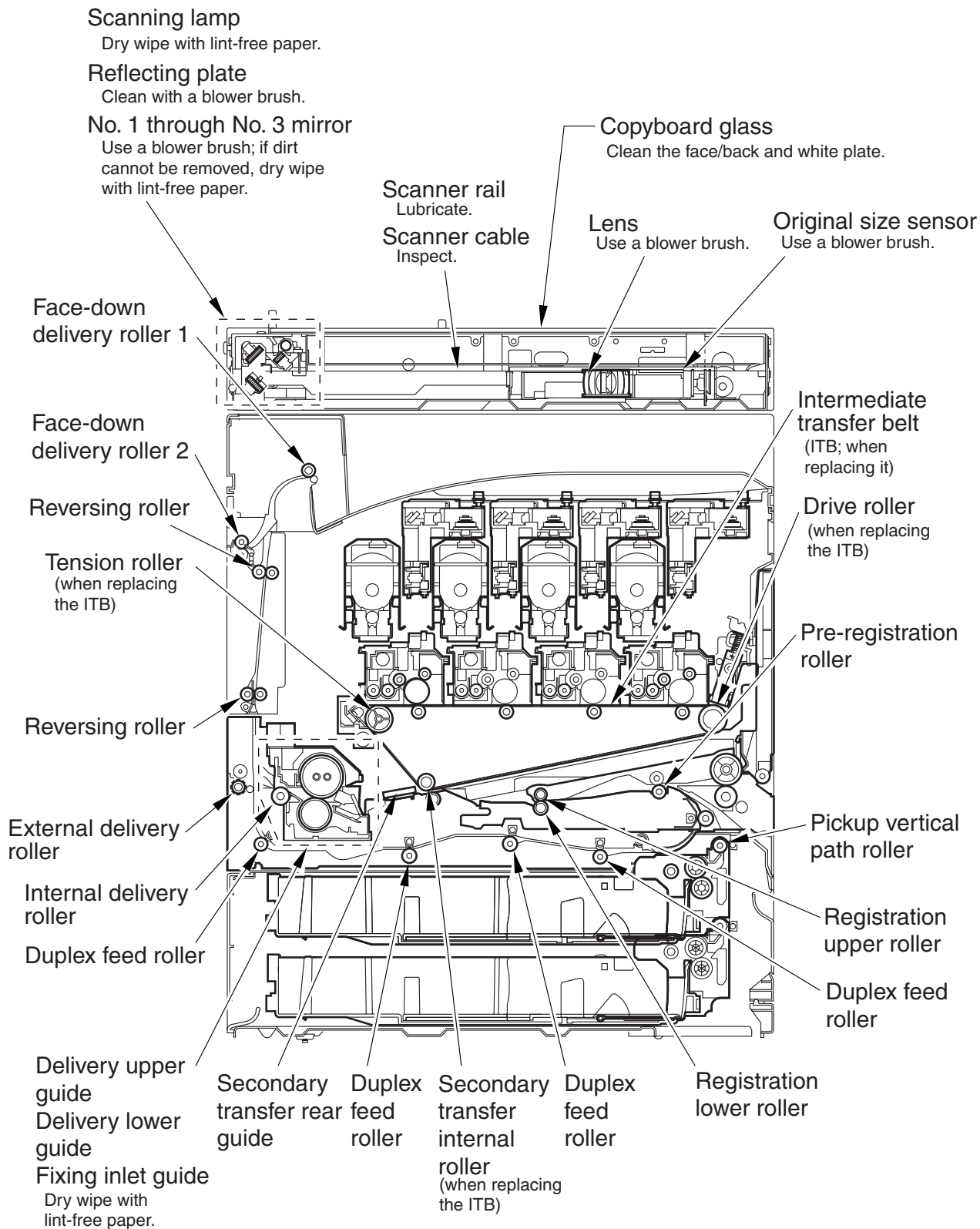

Note: Unless otherwise indicated and for guides coming into contact with paper, use lint-free paper and alcohol.

F01-105-01

CHAPTER 2

STANDARDS AND ADJUSTMENTS

1 Image Adjustments

1.1 Standards for Image Position

The standards for the image margin/non-image width of prints made at 100% are as follows:

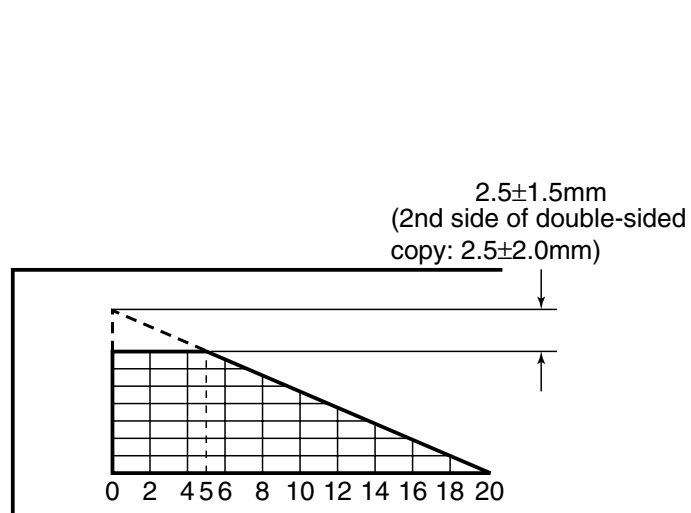

F02-101-01
Leading Edge Non-Image Width

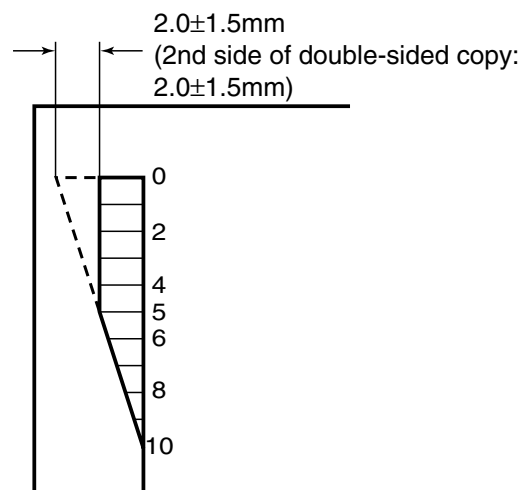

F02-101-02
Left/Right Non-Image Width

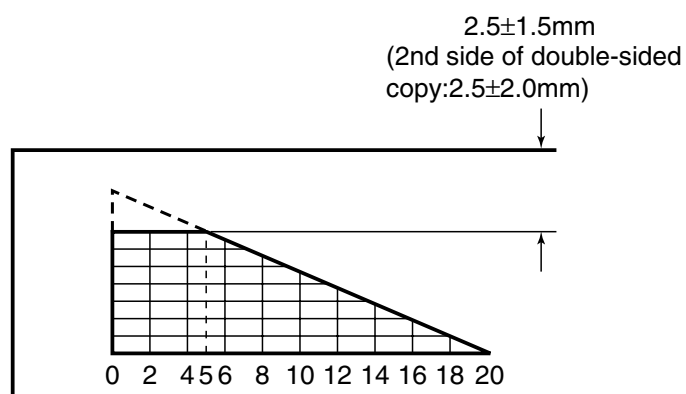

F02-101-03
Leading Edge Image Margin

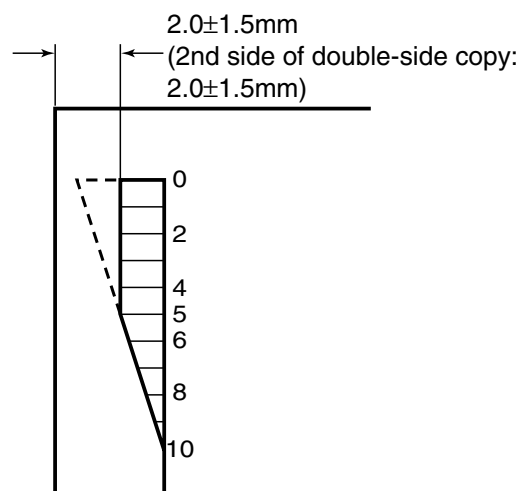

F02-101-04
Left/Right Image Margin

1.2 Checking the Image Position

Make 10 prints each using the following as the source of paper, and check to see that the image margin and non-image width are as indicated:

1. individual cassettes
2. manual feed tray
3. side paper deck
4. duplex unit

If not, perform the following:

1. left/right image margin adjustment (horizontal registration adjustment)
2. leading edge image margin adjustment (registration adjustment)
3. left-right non-image width adjustment (CCD read start cell position adjustment)
4. leading edge non-image width adjustment (scanner image leading edge position adjustment)

1.3 Adjusting the Left/Right Margin

1.3.1 Cassette

- 1) Slide out the cassette 1/2, and open the pickup vertical path cover. (In the case of the 2-cassette pedestal, slide out the cassette 3/4.)
- 2) Remove the 2 screws [1], and detach the right front cover [2]. (Do the same for the 2-cassette pedestal.)

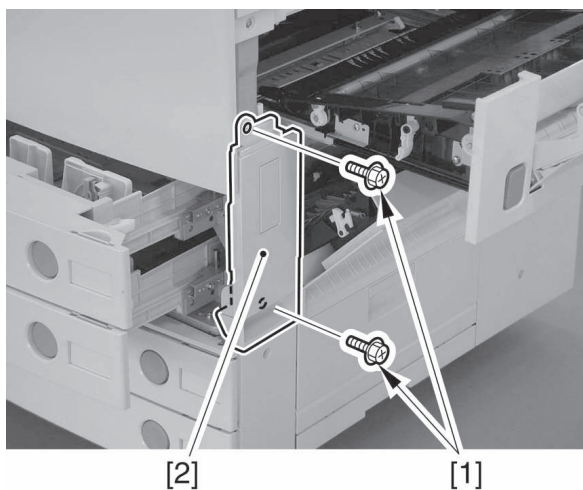

F02-103-01

- Adjusting on the Cassette 1 Side

Insert a screwdriver through the hole in the right front stay, and use the screw [1] to adjust the position of the adjusting plate [2]. (Do the same for the cassette 3/4.)

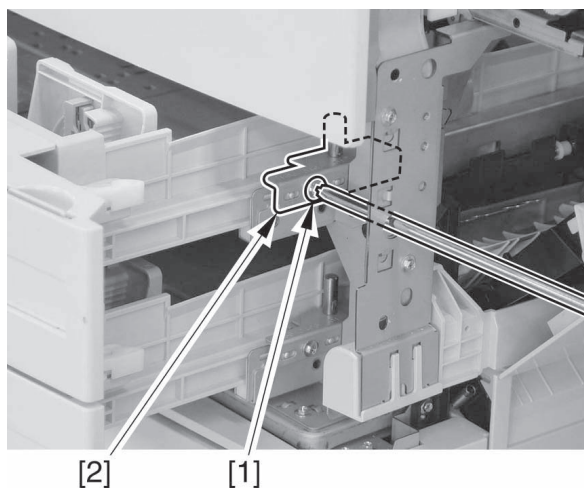

F02-103-02

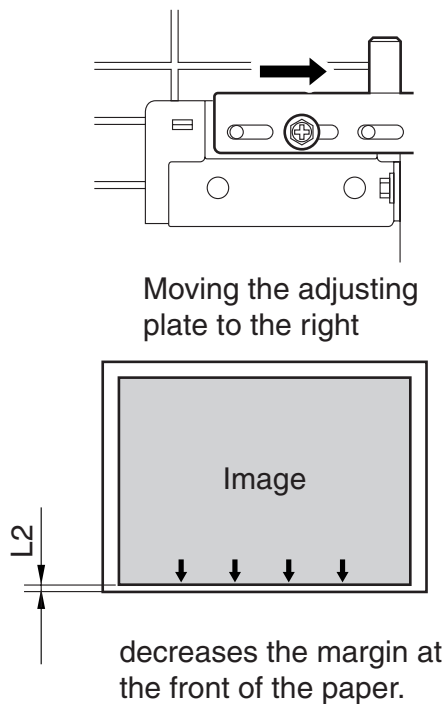

F02-103-03

- Adjusting on the Cassette 2 Side
- 3) Detach the grip [1] found at the right front.

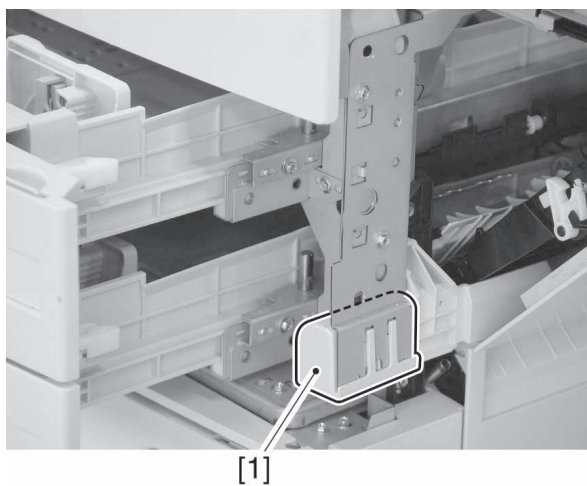

F02-103-04

- 4) Insert a screwdriver through the hole in the right front stay, and loosen the screw [1] to adjust the position of the adjusting plate [2].

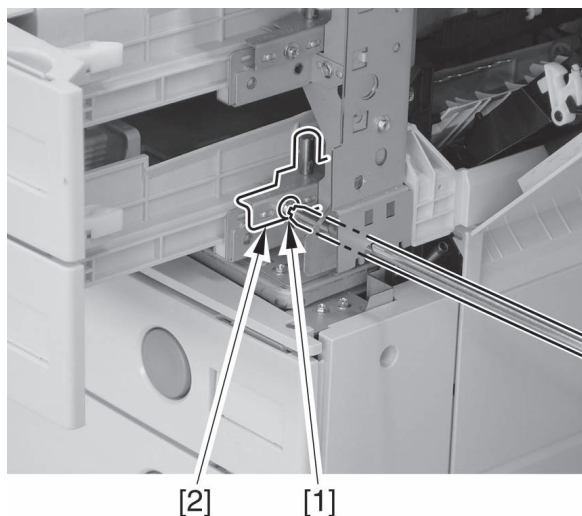

F02-103-05

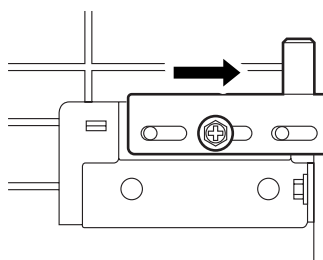

Moving the adjusting plate to the right

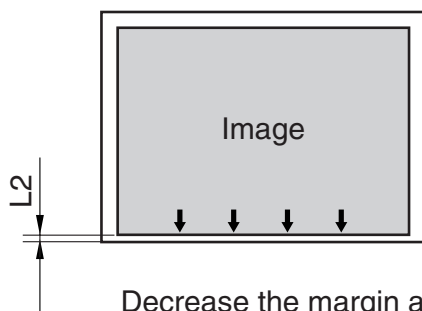

Decrease the margin at the front of the paper.

F02-103-06

- For output from each cassette, check to make sure that the margin (L1) along the leading edge is 2.5 ± 1.5 mm; if not, make the following adjustments:
 - 1) Make the following selections in service mode: COPIER>ADJUST>FEED-ADJ>REGIST.
 - 2) Change the setting to make adjustments.
(A change of '1' will cause a shift of 0.1 mm, and a higher value will move the image toward the leading edge.)

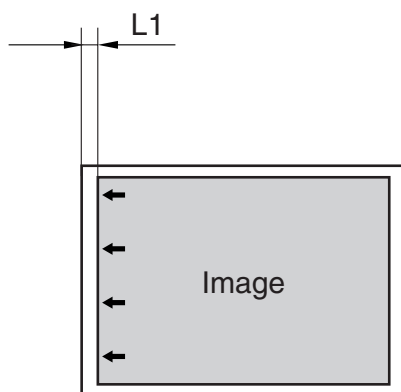

Increasing the value of FEED-ADJ will move the image toward the leading edge of the paper.

F02-103-07

- Adjusting the Image Area (non-image width)
 - 1) Make the following selections in service mode: COPIER>ADJUST>BLANK>BLANK-T/L/B/R.
 - 2) Change the setting to make adjustments.
(An increase by '24' increases the non-image width by about 1 mm, with the range of settings being between 0 and 1000.)

1.3.2 Manual Feed Tray

Loosen the 2 screws [1], and move the position of the slide guide [2] to make adjustments.

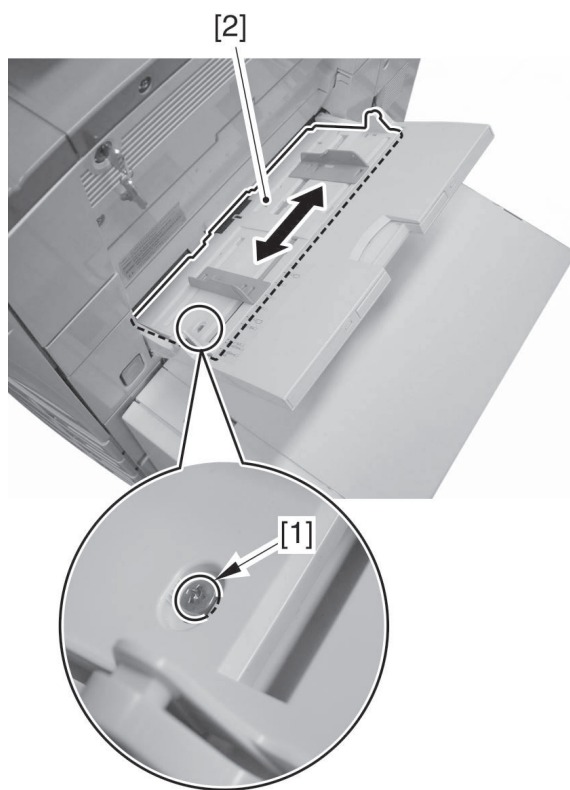

F02-103-08

1.3.3 Side Paper Deck

- 1) Slide out the compartment, and adjust the position of the latch plate [1] of the compartment opening solenoid (SL102) using the 2 screws. (When doing so, refer to the index [3] on the latch plate.)

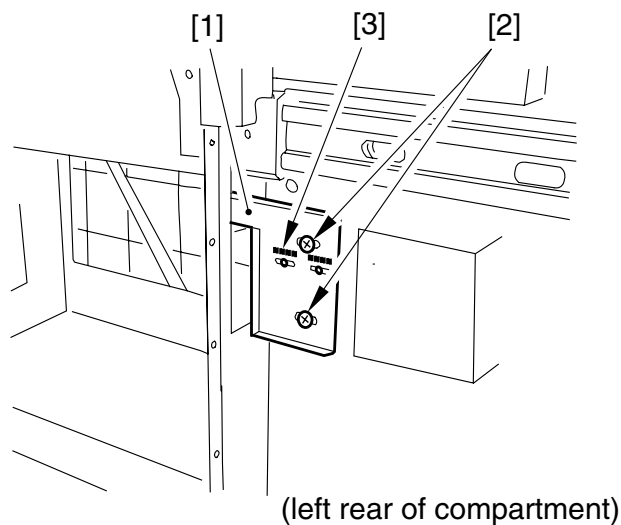

F02-103-09

1.3.4 Duplex Unit

Loosen the adjusting screw [1] to make adjustments. (A single graduation in the index will cause a change of approximately 1 mm.)

- To move the paper to the rear, move it to the left.
- To move the paper to the front, move it to the right.

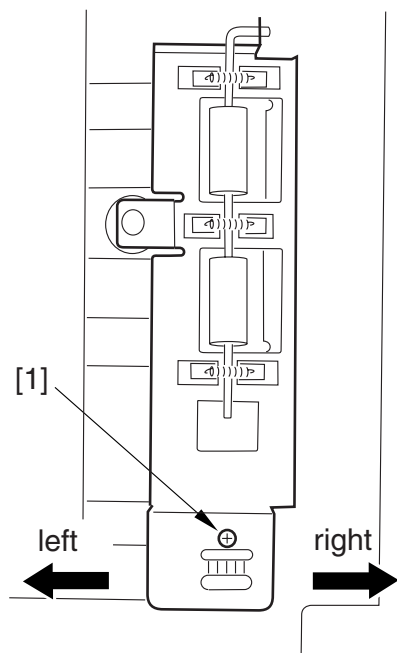

F02-103-10

1.4 Adjusting the Image Leading Edge Margin

- 1) Make the following selections in service mode, and see that the image margin is as indicated: COPIER>ADJUST>FEED-ADJ>REGIST.

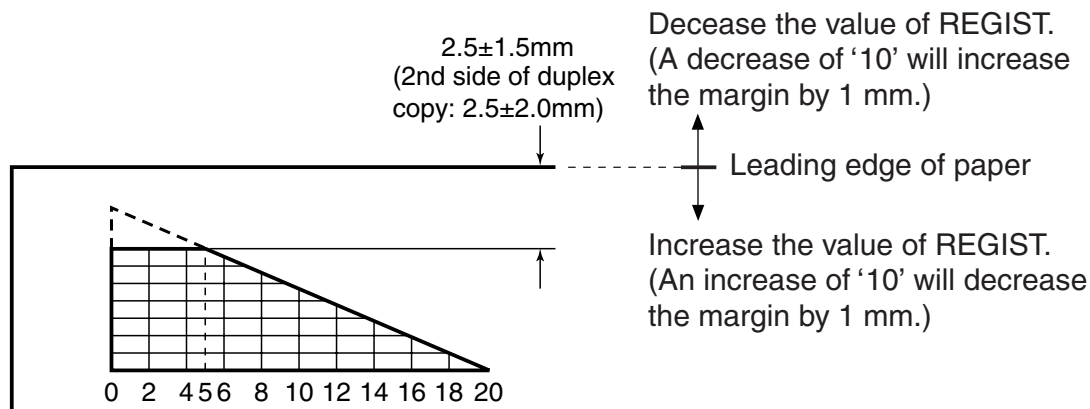

F02-104-01

1.5 Adjusting the Left/Right Non-Image Width

- 1) Make the following selections in service mode, and see that the non-image width is as indicated: COPIER>ADJUST>ADJ-XY>ADJ-Y.

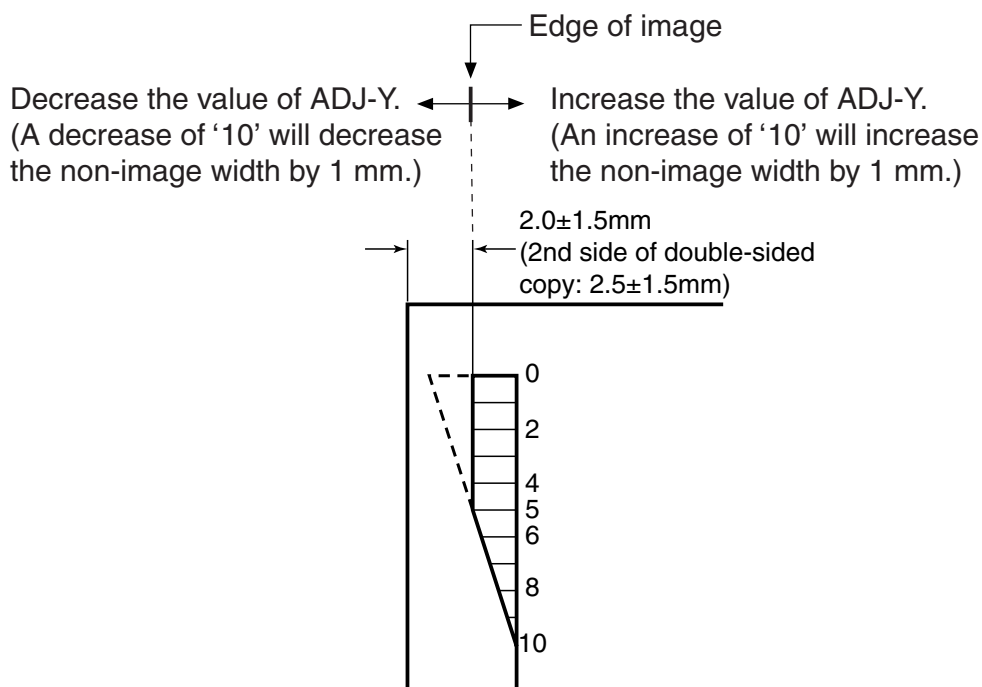

F02-105-01

1.6 Adjusting the Leading Edge Non-Image Width

- 1) Make the following selections in service mode, and see that the non-image width is as indicated: COPIER>ADJUST>ADJ-XY>ADJ-X.

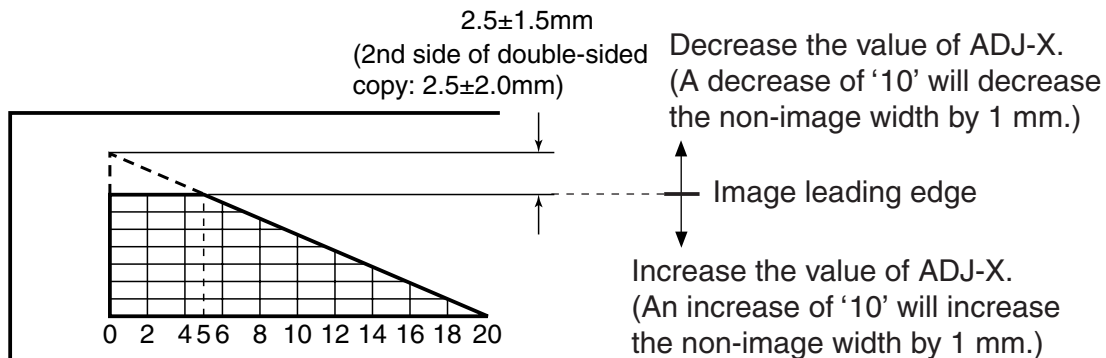

F02-106-01

2 Optical System

2.1 After Replacing the Scanning Lamp

There is no particular work to perform after replacing the scanning lamp.

2.2 After Replacing the Copyboard Glass

See the applicable descriptions under 3 ‘Disassembly and Assembly’ in Chapter 1 ‘Original Exposure System’ of Reader Volume.



COPIER>ADJUST>CCD>W-PLT-X/Y/Z

Use it to enter data for the standard white plate.

2.3 After Replacing the CCD Unit

See the applicable descriptions under 3 ‘Disassembly and Assembly’ in Chapter 1 ‘Original Exposure System’ of Reader Volume.



COPIER>ADJUST>CCD>CCDU-RG/GB

Use it to enter the image position correction value (dependent on the CCD unit).

3 Laser Exposure System

3.1 After Replacing the Laser Unit

See the applicable descriptions under 3 ‘Disassembly and Assembly’ in Chapter 3 ‘Laser Exposure System’ of Printer Volume.



COPIER>FUNCTION>LASER>L-ADJ-0

Use it to execute automatic adjustment of laser intensity.

4 Image Formation System

4.1 After Replacing the Drum Unit

There is no particular work to perform after replacing the drum unit.

4.2 After Replacing the Transfer Unit

There is no particular work to perform after replacing the transfer unit (intermediate transfer unit, secondary transfer unit).

4.3 After Replacing the Pattern Reading Unit

There is no particular work to perform after replacing the pattern reading unit.

5 Fixing System

5.1 After Disassembling the Fixing Unit

See the applicable descriptions under 4 ‘Disassembly and Assembly’ in Chapter 6 ‘Fixing System’ of Printer Volume.



COPIER>FUNCTION>FIXING>NIP-CHK

Use it to generate output for fixing nip width auto measurement.

6 Electrical Parts

6.1 When Replacing the Reader Controller PCB

See the applicable descriptions under 3 ‘Disassembly and Assembly’ in Chapter 1 ‘Original Exposure System’ of Reader Volume.



COPIER>ADJUST>ADJ-XY>ADJ-X

Use it to adjust the scanner leading edge position.

COPIER>ADJUST>ADJ-XY>ADJ-Y

Use it to adjust the CCD read start cell position.

COPIER>ADJUST>ADJ-XY>ADJ-S

Use it to enter an adjustment value for the scanner shading measurement point.

COPIER>ADJUST>CCD>W-PLT-X

Use it to enter white level data for the standard white plate.

COPIER>ADJUST>CCD>W-PLT-Y

Use it to enter white level data for the standard white plate.

COPIER>ADJUST>CCD>W-PLT-Z

Use it to enter white level data for the standard white plate.

COPIER>ADJUST>CCD>CLF-R-RG

Use it to enter a color displacement correction value for sub scanning direction.

COPIER>ADJUST>CCD>CLF-R-GB

Use it to enter a color displacement correction value for sub scanning direction.

COPIER>ADJUST>CCD>CL-R-RG

Use it to enter a color displacement correction value for sub scanning direction.

COPIER>ADJUST>CCD>CL-R-GB

Use it to enter a color displacement correction value for sub scanning direction.

COPIER>ADJUST>CCD>BW-R-RG

Use it to enter a color displacement correction value for sub scanning direction.

COPIER>ADJUST>CCD>BW-R-GB

Use it to enter a color displacement correction value for sub scanning direction.

COPIER>ADJUST>CCD>CCDU-RG

Use it to enter a color displacement correction value for sub scanning direction.

COPIER>ADJUST>CCD>CCDU-GB

Use it to enter a color displacement correction value for sub scanning direction.

COPIER>ADJUST>CCD>FCCDU-RG

Use it to enter a color displacement correction value for sub scanning direction.

COPIER>ADJUST>CCD>FCCDU-GB

Use it to enter a color displacement correction value for sub scanning direction.

6.2 When Replacing the DC Controller PCB

See the applicable descriptions under 5 ‘Disassembly and Assembly’ in Chapter 7 ‘Externals and Controls’ of Printer Volume.

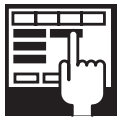

COPIER>ADJUST>LASER>PVE-OFST

Use it to enter an adjustment value for the laser beam position.

COPIER>ADJUST>FEED-ADJ>REGIST

Use it to adjust the timing at which the registration roller clutch goes ON.

COPIER>ADJUST>FEED-ADJ>ADJ-REFE

Use it to adjust the horizontal registration for re-pickup.

COPIER>ADJUST>CST-ADJ>MF-A4R

Use it to adjust the paper width basic value for the manual feed tray.

COPIER>ADJUST>CST-ADJ>MF-A6R

Use it to adjust the paper width basic value for the manual feed tray.

COPIER>ADJUST>CST-ADJ>MF-A4

Use it to adjust the paper width basic value for the manual feed tray.

6.3 When Replacing the Main Controller PCB

See the applicable descriptions under 4 ‘Disassembly and Assembly’ in Chapter 3 ‘Main Controller’ of System Volume.

6.4 When Replacing the SRAM PCB

See the applicable descriptions under 4. ‘Disassembly and Assembly’ in Chapter 3 ‘Main Controller’ of System Volume.

6.5 When Replacing the HDD

See the applicable descriptions under 4. ‘Disassembly and Assembly’ in Chapter 3 ‘Main Controller’ of System Volume.

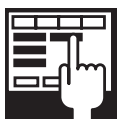

COPIER>FUNCTION>INSTALL>CARD

Use it to indicate that a card reader has been installed.

6.6 When Replacing the Power Supply PCB

There is no particular work to perform after replacing the power supply PCB.

7 Pickup/Feeding

7.1 Adjusting the Horizontal Registration When Replacing the Pickup Cassette

See the applicable descriptions under 8 ‘Disassembly and Assembly’ in Chapter 5 ‘Pickup/Feeding System’ of Printer Volume.



COPIER>ADJUST>FEED-ADJ>ADJ-REFE

Use it to adjust the horizontal registration for re-pickup operation.

7.2 Attaching the Plastic Film for the Face-Down Delivery Guide Unit

See the applicable descriptions under 8 ‘Disassembly and Assembly’ in Chapter 5 ‘Pickup/Feeding System’ of Printer Volume.

7.3 Adjusting the Horizontal Registration When Replacing the Duplex Unit

See the applicable descriptions under 8 ‘Disassembly and Assembly’ in Chapter 5 ‘Pickup/Feeding System’ of Printer Volume.

7.4 When Replacing the Fixing/Feeder Unit Open/Closed Sensor

See the applicable descriptions under 8 ‘Disassembly and Assembly’ in Chapter 5 ‘Pickup/Feeding System’ of Printer Volume.

8 Side Paper Deck

8.1 Adjusting the Paper Level Indicator

If you have moved the drive belt for the paper level indicator or the deck lifter, see the applicable descriptions in the following: Accessories Volume>Chapter 1 Side Paper Deck-P1>5.1.2 Removing the Front Cover.

8.2 Adjusting the Roll Support Plate

If the compartment cannot be opened/closed or cannot be attached to or detached from its host machine, see the applicable descriptions in the following: Accessories Volume>Chapter 1 Side Paper Deck-P1>5.2.7 Adjusting the Roll Position.

8.3 Mounting the Deck Pickup Roller

When mounting the deck pickup roller, see the applicable descriptions in the following: Accessories Volume>Chapter 1 Side Paper Deck-P1>5.4.3 Orientation of the Deck Pickup Roller.

8.4 Adjusting the Deck Separation Roller Pressure

If multiple feeding occurs at time of pickup or pickup failure occurs even after replacing the pickup roller, see the applicable descriptions in the following: Accessories Volume>Chapter 1 Side Paper Deck-P1>5.4.7 Adjusting the Deck Separation Roller Pressure.

8.5 Adjusting the Height of the Side Clip

If the machine is not stable after being connected to its host machine or if it cannot be attached to or detached from its host machine smoothly, see the applicable descriptions in the following: Accessories Volume>Chapter 1 Side Paper Deck-P1>5.2.8 Adjusting the Height of the Side Clip.

8.6 Routing the Lifter Cable

If the lifter cable has become slack or the holding plate fails to remain level, see the applicable descriptions in the following: Accessories Volume>Chapter 1 Side Paper Deck-P1>5.3.7 Routing the Lifter Cable.

CHAPTER 3

CORRECTING FAULTY IMAGES

1 Making Initial Checks

1.1 Site Environment

Be sure of the following:

- a. The voltage of the power supply is as rated ($\pm 10\%$). The power plug remains connected throughout day and night.
- b. The site is not a high temperature/humidity environment (near a water faucet, water boiler, humidifier), and it is not in a cold place. The machine is not near a source of fire or dust.
- c. The site is not subject to ammonium gas.
- d. The site is not exposed to direct rays of the sun. (Otherwise, provide curtains.)
- e. The site is well ventilated, and the floor keeps the machine level.
- f. The machine's power plug remains connected to the power outlet.

1.2 Checking the Paper

- a. The paper is of a recommended type.
- b. The paper is not moist. Try paper fresh out of package.

1.3 Checking the Placement of Paper

- a. Check the cassette and the manual feed tray to see if the paper is not in excess of a specific level.
- b. If a transparency is used, check to make sure that it is placed in the correct orientation in the manual feed tray.

1.4 Checking the Durables

Check the table of durables to see if any has reached the end of its life.

1.5 Checking the Periodically Replaced Parts

Check the scheduled servicing table and the periodically replaced parts table, and replace any part that has reached the time of replacement.

1.6 Checking the Units and Functional Blocks

[Reader Unit]

- Check the optical system (mirror, white plate, copyboard glass, reflecting plate) for damage and foreign matter.
- Check the mirror base to see that it moves smoothly and its rail is free of dirt.
- Check the scanning lamp to see it is free of flickering.
- Check the scanner cable to see that it is correctly routed.
- Check the scanner to see that it is free of condensation.

[Process System]

- Check to see that the toner container contains toner.
- Check to see that the drum unit is properly fitted.
- Check the photosensitive drum to see that it is free of damage and dirt.
- Check the window of the SALT sensor to see if it is free of dirt.

[Transfer System]

- Check the secondary transfer unit to see that it is free of foreign matter.
- Check the ITB/secondary transfer external roller for wear, scratches, dirt, and deformation.
- Check the blade of the ITB cleaning unit for tear, peeling, deformation, and stray toner.

[Fixing System]

- Check the fixing roller/pressure roller for wear, tear, and deformation.
- Check the fixing heater (main/sub) to see that it operates when power is turned on.
- Check the fixing thermistor to see that it is free of an open circuit.
- Check the thermal switch to see that there is electrical continuity.

[Paper Feeding System]

- Check to see if there is residual paper or other foreign matter.
- Check to see if there is a buildup of paper lint on the pickup, feeding, and separation rollers. Check the rollers for wear, tear, dirt, and deformation.
- Check the pre-registration roller, registration roller (upper/lower), and paper path roller for wear, tear, and dirt, and deformation.
- Check the feeding guide for wear, tear, dirt, and deformation.
- Check the paper for a bent leading edge, curling, waving, and absorption of moisture.
- Check the paper and/or transparency to see if it is a recommended type. If not, try a recommended type to see if the symptom in question still occurs.

[Mechanical System]

- Check to see if the load of the drive system is excessive.
- Check the gears for wear and tear (chipping).

[Cassettes]

- Check to see if the cassettes are properly fitted. Check to see if the paper size is correctly set. Try replacing with a normal cassette to see if the symptom in question still occurs.
- Check to see that the holding plate of the cassette moves smoothly and that it is free of deformation.
- Check to see that the side guide plate and the rear guide plate of the cassette are fitted correctly.
- Check to see if the switch of the cassette heater is turned on (if the machine is equipped with a cassette heater).

[Service Mode]

- Check to see if the various CCD adjustment values are as indicated on the service label. (COPIER>ADJUST>CCD>all items)
- Check to see if the machine executes registration adjustment. (COPIER>ADJUST>FEED-ADJ>REGIST/ADJ-REFE)
- Check to see if the machine correctly detects the internal temperature/humidity. (COPIER>DISPLAY>ANALOG>TEMP/ABS-HUM)
- Check to see if the image read position is correctly adjusted. (COPIER>ADJUST>ADJ-XY>ADJ-X/ADJ-Y/ADJ-Z)
- Check to see if the paper reference value data is correct. (COPIER>FUNCTION>CST-ADJ)
- Check to see that the value of ADJUST/OPTION is as indicated on the service label.
- Check to see if 'error clear' has been initialized. (COPIER>FUNCTION>CLEAR>ERR)

[General]

- Is the power plug properly connected?
- Is the rated AC voltage present at the power outlet?
- Are the sensors, clutches, motors, and solenoids operating normally? Are the connectors free of poor contact?
(Be sure to check the routes of power and signals by referring to the general circuit diagram.)
- Has the leakage breaker or the circuit breaker gone ON?
- Is there biting of a wire or a loose screw?
- Are all external covers attached properly?

- Are the main power switch and the control panel power switch ON?
- Are the power cable and the signal cable to all accessories routed correctly?
- Does the cover switch operate normally?
- Is the fuse on each PCB blown?
- Is the user aware of the correct use of the machine?

1.7 Others

If a machine is brought from a cold to warm place, condensation can occur inside it, leading to various problems:

- a. condensation on the BD sensor can cause problems associated with E110.
- b. condensation on the LDE lens can cause image in sub scanning direction to be too light.
- c. condensation on the mirror of the reader unit or on the copyboard glass can cause images to be too light.
- d. condensation on the pickup or feeder guide can cause paper feeding faults.

If any of the foregoing (a through c) occurs, use the following service mode to correct it (Chapter 5 ‘Service Mode’ of ‘Troubleshooting’):

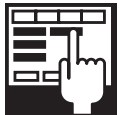

COPIER>FUNCTION>INSTALL>DRY-RT

Use it to eliminate condensation at time of installation work.

If d has occurred, dry wipe the pickup and feeder units.

Moreover, the toner container and the drum unit can also develop condensation if it is brought in from a cold to warm place (unpacked). To prevent condensation, advise the user to leave them alone for 1 to 2 hours before unpacking them at the site.

As necessary after installation, use the following service mode (Chapter 5 ‘Service Mode’ of ‘Troubleshooting’):

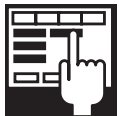

COPIER>OPTION>BODY>SLPOFF01 to SLPOFF12

Use it to disable sleep mode.

2 Test Print

The machine offers 6 types of test prints (TYPE), enabling identification of a fault in images with reference to test prints.

If a fault appearing on a normal print does not show on a test print, the cause may be assumed to be on the PDL input side or the reader unit side.

2.1 Test Print TYPE

TYPE NO.	Description
0	normal copy/print
1 to 3	– (for R&D)
4	16 gradations
5	full halftone
6	grid
7 to 9	– (for R&D)
10	MCYBk horizontal stripe (sub scanning direction)
11	– (for R&D)
12	64 gradations
13	– (for R&D)
14	full color 16 gradations
15 to 100	– (for R&D)

2.2 Selecting a Test Print TYPE

- 1) Set the print count and paper size.
- 2) Make the following selections in service mode: COPIER>TEST>FG.
- 3) Make the following selections: COPIER>TEST>PG>TYPE.
- 4) Using the keypad, enter the desired TYPE No., and press the OK key.
- 5) Using 'COLOR-Y/M/C/K', select the desired color (output at '1').
- 6) Using 'DENS-Y/M/C/K', set the desired density. (valid only for TYPE=5)
- 7) Press the Start key.

2.3 16 Gradations (TYPE=4)

Use this test print to check gradation, fogging, white lines, or uneven density at the front/rear.

a. Gradation

If the reproduction of 16 gradations is not as expected, suspect a fault in the drum unit or the laser exposure system.

b. Fogging

If fogging is limited to the white area of the following illustration, suspect a fault in the drum unit or the laser exposure unit.

c. Vertical White Lines/Black Lines

If a white line is found in the image, suspect a fault in the developing system.

d. Uneven Density at the Front/Rear

If uneven density is found at the front/rear, suspect a fault in the drum unit, laser exposure system, or transfer unit.



F03-203-01

2.4 Full Halftone (TYPE=5)

Use this test print to check transfer failure, black lines, white lines, or irregular intervals.



1. You can select a specific color to develop in user mode using 'COLOR-Y/M/C/K' in service mode (COPIER>TEST>PG).
2. If you want to change the density of the test print, use the following in service mode: TEST>PG>DENS-Y/M/C/K.

a. Transfer Failure

If transfer failure occurs, suspect a fault in the transfer (intermediate/secondary) unit.

b. Uneven Density in Horizontal Direction

If uneven density occurs in horizontal direction, suspect a fault in the photosensitive drum drive unit, drum ITB motor, or drum unit.

c. Uneven Density in Vertical Direction

If uneven density occurs in horizontal direction, suspect dirt on the LDE lens, a fault in the drum unit, or deterioration of the intermediate transfer belt.

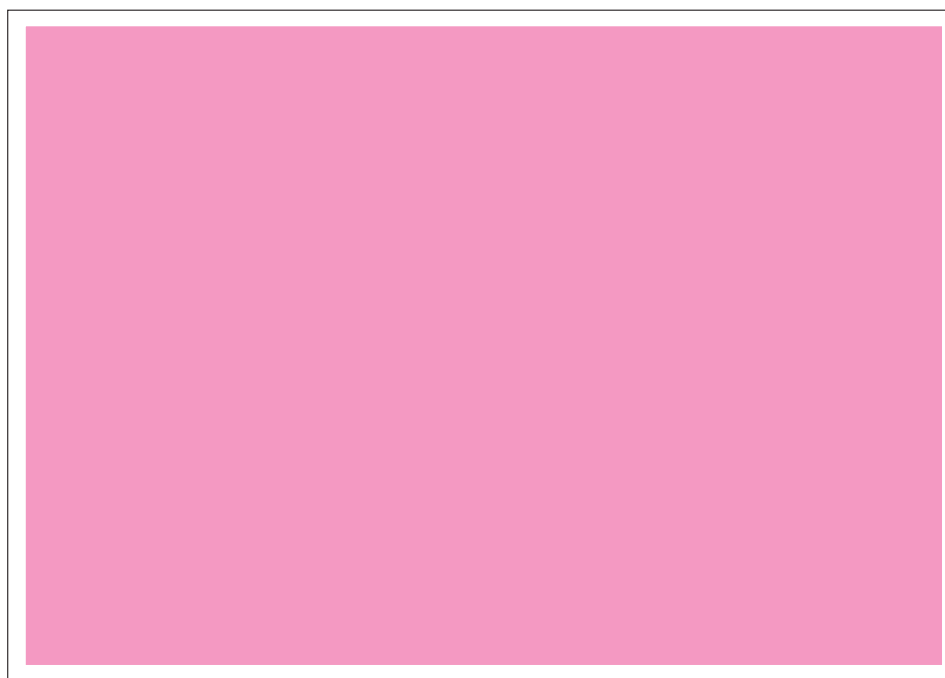

COLOR-M=1, COLOR-Y/C/K=0

F03-204-01

2.5 Grid (TYPE=6)

Use this test print to check color displacement, right angle, or straight line.

a. Color Displacement

If color displacement occurs, suspect a fault in any of the laser exposure system, transfer (intermediate/secondary) unit, or photosensitive drum drive unit.

b. Right Angle, Straight Line

If right angles or straight lines are faulty, suspect a fault in the laser exposure system, registration (upper/lower) roller, or secondary external roller (i.e., the shape of the rollers).

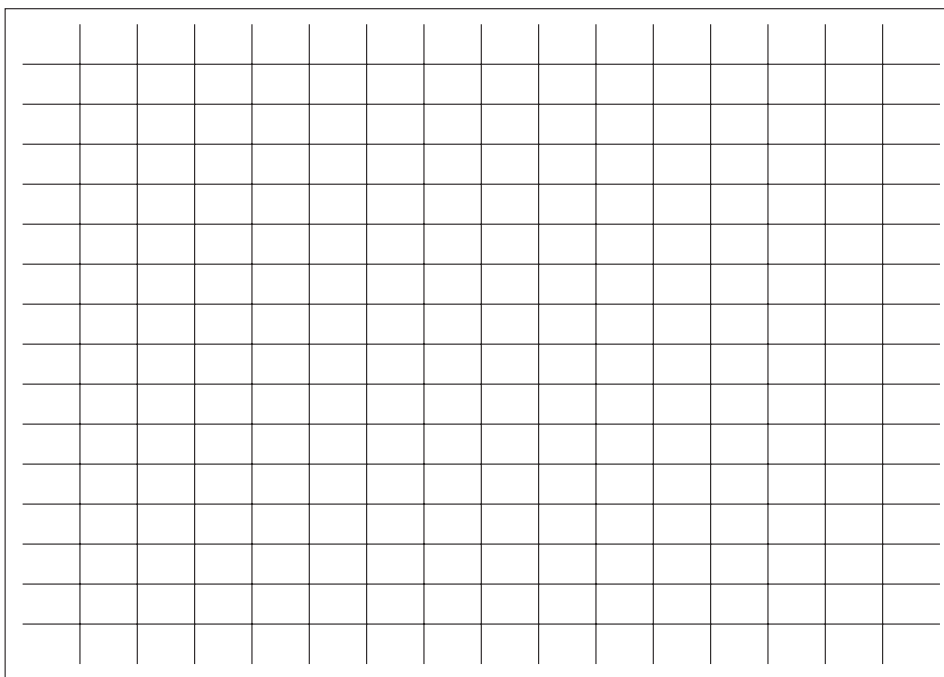

F03-205-01

2.6 MCYBk Horizontal Stripe (TYPE=10)

Use this test print to check the density of dark areas of individual colors, balance among colors, and white lines in relation to development.

a. Solid Density of Colors and Balance Among Colors

- The density must not be appreciably low (light).
- If the density of a specific color is too low, suspect a fault in the developer, primary transfer roller, laser exposure system, or high-voltage system used for that color.

b. White/Black Lines

If a white/black line occurs for a specific color, suspect a fault in the drum unit used for that color or dirt in the laser optical path.

c. Uneven Density at the Front/Rear

If uneven density occurs for a specific color, suspect a fault in the drum unit, laser exposure system, or transfer (intermediate/secondary) unit.

If uneven density occurs for all colors, suspect deterioration of the intermediate transfer unit.

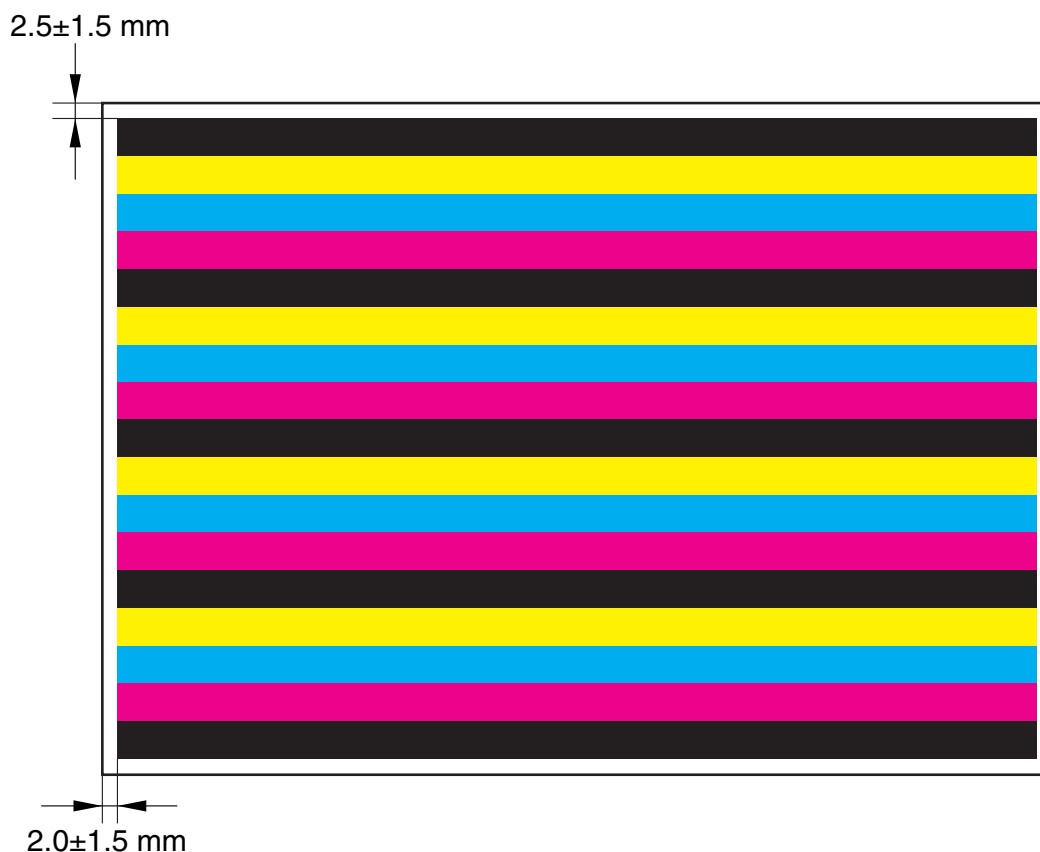

F03-206-01

2.7 64 Gradations (TYPE=12)

Use this test print to check the reproduction of gradation for all colors (YMCBk) at once.



F03-207-01

2.8 Full Color 16 Gradations (TYPE=14)

Use this test print to check gray balance, the reproduction of gradation for individual colors (YMCKBk), or fogging.

a. Gray Balance

Check to see if each color is reproduced at an even level of density in the gray scale area.

b. Gradation

Check the reproduction of gradation of individual colors (YMCKBk) and for the difference, if any, in density.

c. Fogging

If fogging occurs in the white area, suspect a fault in the developing system or the photosensitive drum, or improper adjustment of the laser exposure system.

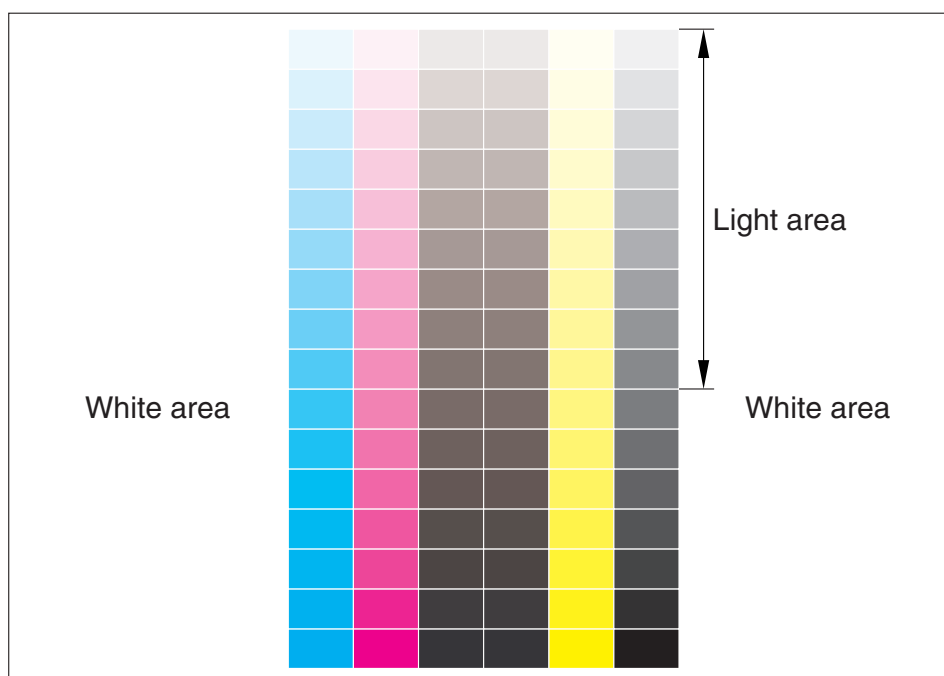

F03-208-01

3 Image Fault Case Studies

A. Image Fault Case Samples (Note: The following is a collection of faulty images that can occur on A4 or larger paper; they have been artificially created, and may slightly differ from actual faulty copies.)

1. Light Image in Middle

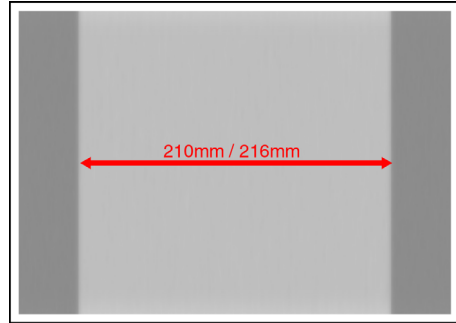

2. Toner Collection Along Image End

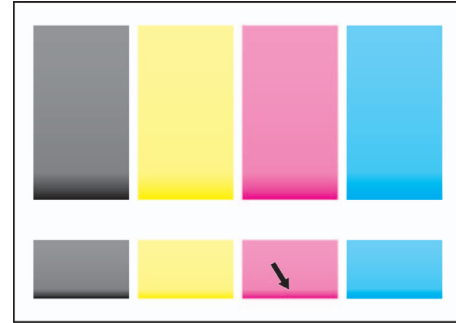

3. Uneven Density at 44-mm Intervals

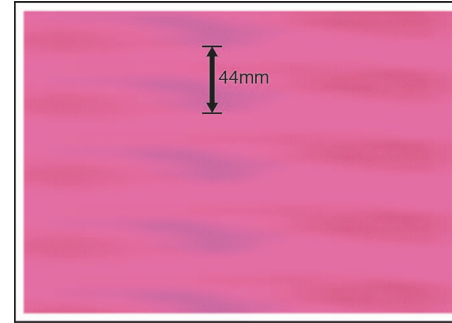

4. Uneven Density at Angle at 12-mm Intervals

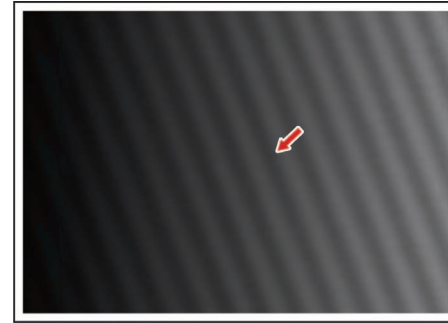

5. Uneven Density in vertical direction

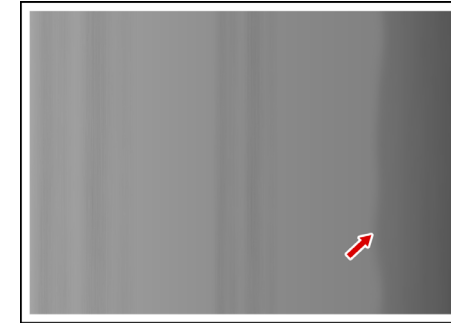

6. Mottled Image



7. Flow image on Side

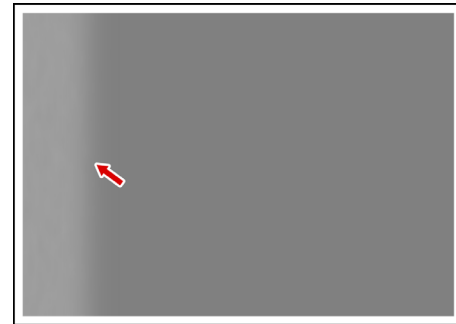

8. Toner Stray

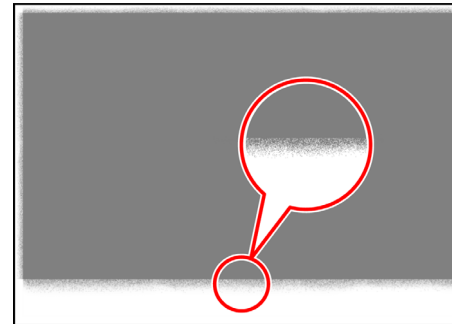

9. 47-mm Horizontal Line

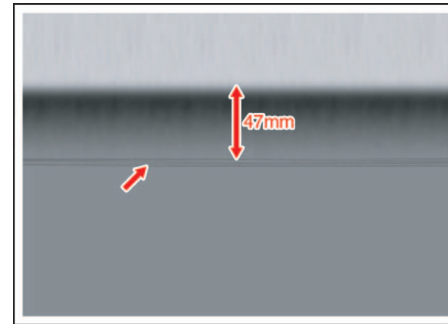

10. 100-mm Horizontal Line

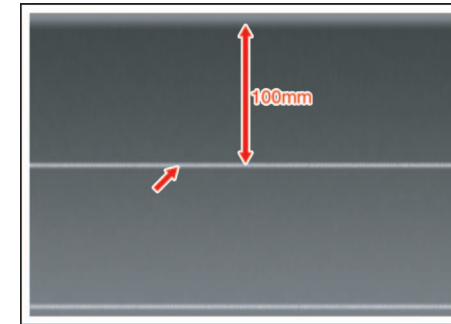

11. White Spot Along Trailing Edge



12. Vertical Lines (Charging Roller)

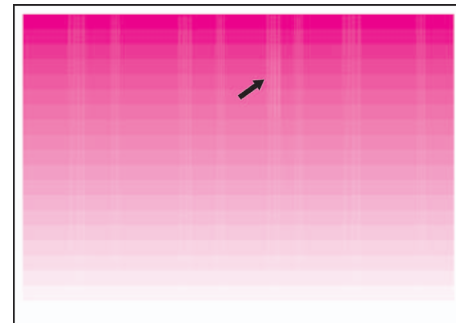

13. Trace of Delivery Clip

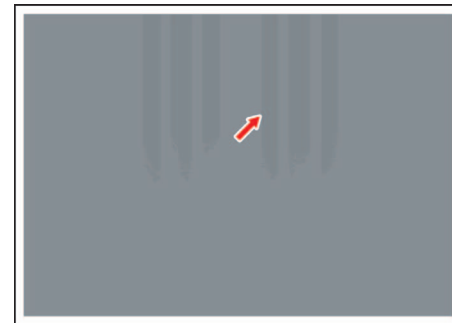

14. Trace of Pickup Roller Along Leading Edge

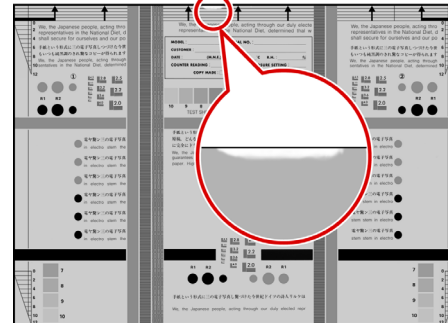

15. Trace of Pickup Roller



B. Image Fault Case Samples (Note: The following is a collection of faulty images that can occur on A3 or larger paper; they have been artificially created, and may slightly differ from actual faulty copies.)

1. White Spot on Edge

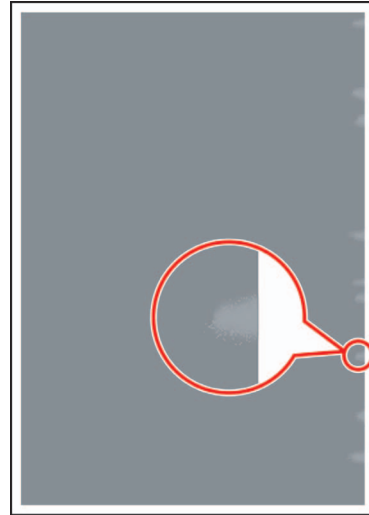

2. 20 to 30-mm White Spot

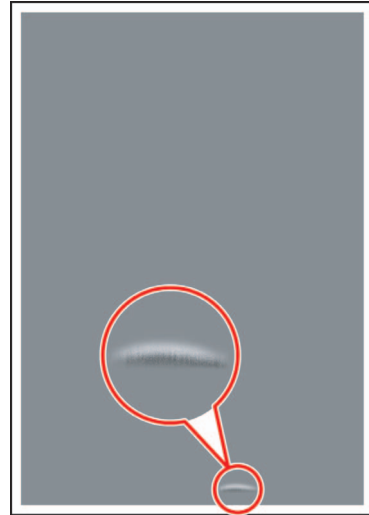

3. White Spots Leading Edge

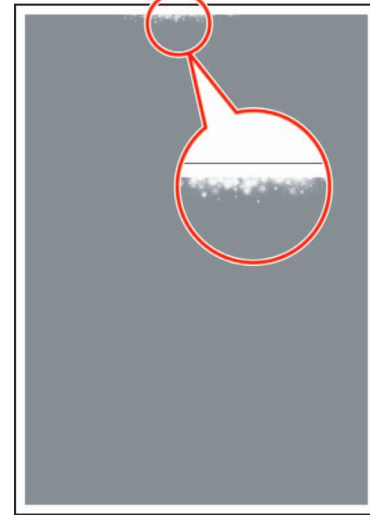

4. Fine White Spot Near 30 mm of Trailing Edge

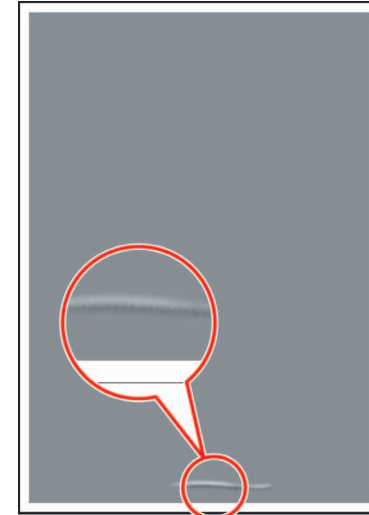

5. Line Along Trailing Edge

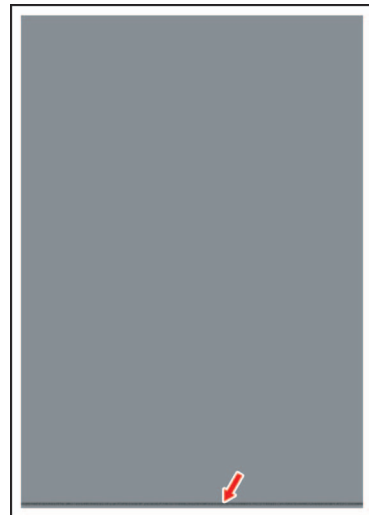

6. Poor Parallel Reproduction Along Trailing Edge



7. Rub off Along Trailing Edge

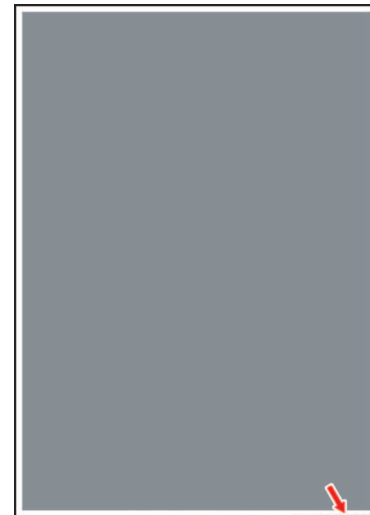

3 Image Fault Case Studies



If you need to use service mode to correct a fault, be sure always to refer to the appropriate instructions on the pages that follow:

3.1 The output is completely blank.

Troubleshooting Volume>Chapter 3 Troubleshooting Image/Operation Faults>1.6 Checking the Units and Functional Blocks

3.2 The output is completely black.

Troubleshooting Volume>Chapter 3 Troubleshooting Image/Operation Faults>1.6 Checking the Units and Functional Blocks

3.3 The output is too light.

Title	Cause	Correction	Remarks
<ul style="list-style-type: none"> When an image with a high color ratio is generated continuously, the density at the rear tends to become too low (light). It tends to occur simultaneously with uneven density in diagonal direction at intervals of 12 mm. 	<p>The amount of toner supplied cannot keep up with the amount of toner being consumed.</p>	<p>Set '1' or '2' to the following in service mode: COPIER>OPTION>BODY>SLV-UP.</p>	<ul style="list-style-type: none"> adverse effect of setting it to '1': the life of the drum unit will decrease. adverse effect of setting it to '2': the life of the drum unit will decrease, and the print productivity will also decrease.

Title	Cause	Correction	Remarks
<ul style="list-style-type: none"> When an image with a high color ratio is generated continuously, the density at the rear tends to become too low (light) and, thereafter, the overall density tends to decrease. 	<p>The amount of toner supplied cannot keep up with the amount of toner being consumed.</p>	<p>Set '1' or '2' to the following in service mode: COPIER>OPTION>BODY>SLV-UP.</p>	<ul style="list-style-type: none"> adverse effect of setting it to '1': the life of the drum unit will decrease. adverse effect of setting it to '2': the life of the drum unit will decrease, and the print productivity will also decrease.
<ul style="list-style-type: none"> In a high humidity environment, the density tends to fluctuate (increase) immediately after replacement of the drum unit. 	<p>The developer is exposed to the moisture of the environment and, as a result, the charge on the toner decreases to increase the density.</p>	<p>Execute the following in user mode: adjust/clean>auto gradation adjustment>full correction.</p>	
<ul style="list-style-type: none"> After passing images of a high color ratio continuously, the density fluctuates appreciably. 	<p>The balance in toner inside the developing assembly fails; when the image stabilization mechanism goes ON in this condition, the machine tends to base its contrast potential on the existing condition. When the balance between the toner and the carrier inside the developing assembly returns, the density fluctuates in relation to the selected contrast potential.</p>	<p>Execute the following in user mode: adjust/clean>auto gradation correction>full correction.</p>	
<ul style="list-style-type: none"> In a high humidity environment, the middle of a halftone image tends to become low in density after passage of a transparency. 	<p>The coating agent on the surface of the transparency sticks to the ITB, making transfer of toner from the ITB to paper difficult.</p>	<p>Execute the following in user mode: adjust/clean>internal cleaning.</p>	<p>See the Image Fault Sample A-1.</p>

3.4 The output is too dark/has fogging.

Title	Cause	Correction	Remarks
<ul style="list-style-type: none"> In a low humidity environment, reverse fogging tends to occur when the drum unit has been in use for a long time. 	<p>The toner has deteriorated, thus not being able to take on adequate negative charge.</p>	<p>Replace the drum unit of the color in question.</p>	<p>As a temporary measure, turn off and then on the main power switch so that the formation of a sample image (for image stabilization control) will remove the faulty toner from the drum.</p>
<ul style="list-style-type: none"> In a high humidity environment, fogging occurs in Y areas if the machine has been left alone for a long time (e.g., 2 days). 	<p>The toner (MCBk) charged to a positive potential and existing on the photosensitive drum is drawn to the Y toner charged to a negative potential and existing on the ITB.</p>	<p>Generate about 10 prints of solid images of the color in question using A3 paper.</p>	
<ul style="list-style-type: none"> Toner collection occurs along image end when the machine is left alone for a long time (e.g., 1 week). 	<p>When the machine is left alone for a long time, the level of charge on the toner tends to decrease.</p>	<p>Generate about 10 prints of solid images of the color in question using A3 paper.</p>	<p>See the Image Fault Sample 2.</p>

3.5 The output is uneven in density/color.

Title	Cause	Correction	Remarks
<ul style="list-style-type: none"> Uneven density occurs at 44 mm intervals when the drum unit has been in use for a long time. 	<p>Toner sticks to the charging roller, and soils it.</p>	<p>Replace the drum unit of the color in question. (Identify the drum unit by generating test pattern TYPE=5 (halftone).)</p>	<p>See the Image Fault Sample A-3.</p>
<ul style="list-style-type: none"> Uneven density at an angle and at 12 mm intervals; tending to occur simultaneously with low density at the rear or over the entire image when an original of a high color ratio is printed continuously. 	<p>The amount of toner being supplied cannot keep up with the amount of toner being consumed.</p>	<p>Set '1' or '2' to the following in service mode: COPIER>OPTION>BODY>SLV-UP.</p>	<p>See the Image Fault Sample A-4.</p> <ul style="list-style-type: none"> adverse effect of setting it to '1': the life of the drum unit will decrease. adverse effect of setting it to '2': the life of the drum unit will decrease, and the print productivity will also decrease.
<ul style="list-style-type: none"> Uneven density in vertical direction occurs when images with a high color ratio are generated in large volumes. 	<p>Filming (white soiling) occurs on the surface of the photosensitive drum, affecting exposure.</p>	<p>Be sure to refer to the instructions indicated on how to clean the photosensitive drum (dry wiping the photosensitive drum of the color in question).</p>	<p>See the Image Fault Sample A-5.</p>
<ul style="list-style-type: none"> Uneven density occurs at 0.8 mm intervals, tending to be noticeable in halftone images. 	<p>The rotation of the photosensitive drum drive gear is uneven.</p>	<p>Set '2' to the following in service mode: COPIER>OPTION>BODY>TMC-SLCT.</p>	<p></p>
<ul style="list-style-type: none"> Uneven gloss (about 155 mm) occurs along the leading edge of the 1st print when an image with a high color ratio is printed on thick paper (209 g or more and coated paper). 	<p>There is an appreciable difference in temperature between the 1st rotation of the fixing roller and its 2nd and subsequent rotations (with a peripheral length of 155 mm).</p>	<p>–</p>	<p>If prints are made continuously, the fault does not occur on the 2nd and subsequent prints.</p>

Title	Cause	Correction	Remarks
<ul style="list-style-type: none"> Mottled image occurs when large numbers of prints are made daily and, in addition, the drum unit has been in use for a long time. 	<p>The toner in the developing assembly is caking into lumps.</p>	<p>Execute the following in user mode: adjust/clean>internal cleaning.</p>	<p>See the Image Fault Sample A-6. Execute the mode every 4000 prints as a guide.</p>
<ul style="list-style-type: none"> Uneven image occurs in halftone images. (rough texture) 	<p>The level of secondary transfer current is too high, thus decreasing the transfer efficiency because of re-transfer.</p>	<p>Execute the following in user mode: adjust/clean>internal cleaning. With care, make use of the following in service mode: COPIER>ADJUST>HV-TR>2TR-TGT/2TR-SHR/TR-ENV/TR-PPR/TR-CLR/TR-DUP.</p>	<ul style="list-style-type: none"> adverse effect of changing the setting: the toner can move astray, increasing spots.
<ul style="list-style-type: none"> The hues are not appropriate or the density is not even when images with a low color ratio have been generated continuously. 	<p>The toner inside the developing assembly has remained unconsumed without being stirred for a long time, thus increasing the charge of the toner and, ultimately, causing re-transfer or mixing of colors.</p>	<p>Set '1' to the following in service mode: COPIER>OPTION>BODY>DEVL-PTH.</p>	<ul style="list-style-type: none"> adverse effect of setting it to '1': the life of the toner container will decrease.
<ul style="list-style-type: none"> In a high humidity environment, uneven density occurs in Bk solid images. (rough texture) 	<p>The level of secondary transfer current is too high, thus decreasing the transfer efficiency because of re-transfer.</p>	<p>Execute the following in user mode: adjust/clean>auto gradation correction>full correction. Or, add a cassette heater.</p>	

Cleaning the Photosensitive Drum

1) Open the front cover, and shift down the intermediate transfer unit releasing lever.

2)



Do not rotate or shake the drum unit as shown.

Place 2 to 3 sheets of paper on the floor; then, open the drum unit cover, take out the drum unit, and place it on the paper. (F03-305-01)

3) Rotate the drum unit in the direction of the arrow so that the drum is at the top. (F03-305-02)

4)



When cleaning the photosensitive drum unit, take care not to peel the sheet [1] or damage it. (F03-305-03)

While taking care not to damage the photosensitive drum [1], wipe the surface about 5 times with lint-free paper. (F03-305-04)

5)



When rotating the photosensitive drum [1], be sure to do so in the direction of the arrow. Otherwise, the orientation of the auxiliary brush will change, preventing correct development.

Hook your fingers on both ends of the photosensitive drum, and rotate it; repeat step 4) to clean the face of the drum. (F03-305-05)

6) Rotate it in the direction opposite the direction indicated in step 3) so that the drum unit is at the bottom. (F03-305-06)

7) Fit the drum unit in the machine, and generate a test pattern (half-tone).



F03-305-01



Place the drum unit so that the arrow on the top is on the right side, and rotate it toward the rear.

F03-305-02

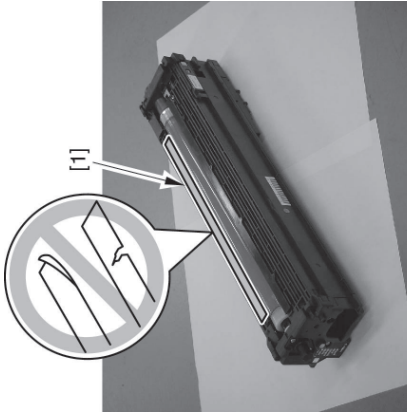

Be sure that the sheet is farther to the rear than the photosensitive drum.

F03-305-03

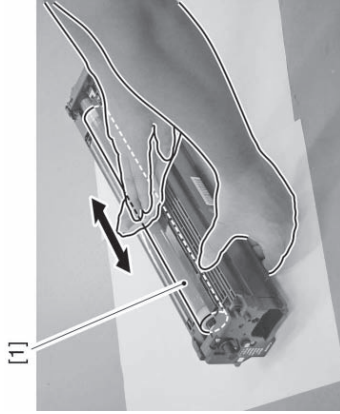

F03-305-04

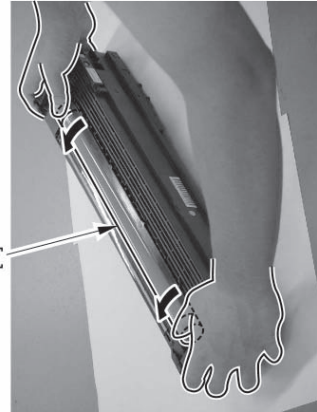

F03-305-05



F03-305-06

3.6 The output is blurry, smeared, or fuzzy.

Title	Cause	Correction	Remarks
<ul style="list-style-type: none"> If the machine has been left alone in a high humidity environment for a long time (e.g., 2 days), flow image can occur along the edges of the sheet. 	<p>The chemical elements on the surface of the photosensitive drum absorb moisture from the atmosphere, thus decreasing the resistance on the surface of the drum.</p>	<p>Add a cassette heater (to keep the inside of the machine warm). Execute the following in user mode: <code>adjust/clean>internal cleaning.</code></p>	<p>See the Image Fault Sample A-7. The symptom may disappear when several prints have been made on A3 paper.</p>
<ul style="list-style-type: none"> Toner stray tends to occur around an image with a high color ratio in a low humidity environment. 	<p>The level of the secondary transfer current is too low, thus failing to transfer the toner from the ITB.</p>	<p>With care, use the following in service mode: <code>COPIER>ADJUST>HV-TR>2TR-TGT/2TR-SHR/TR-ENV/TR-PPR/TR-CLR/TR-DUP.</code></p>	<p>See the Image Fault Sample A-8. <ul style="list-style-type: none"> adverse effect of changing the setting: it can worsen white spots, transfer faults, or fogging (rough texture). </p>

3.7 The output has transfer faults/lines.

Title	Cause	Correction	Remarks
<ul style="list-style-type: none"> An abrupt change occurs in the amount of toner deposited over the entire length of the drum axis when full color image is made. It is a 47-mm horizontal line. 	<p>An abrupt change (increase) has occurred in the amount of toner on the photosensitive drum, causing uneven rotation of the drum and, ultimately, a discrepancy in exposure.</p>	<p>Set '2' to the following in service mode: COPIER>OPTION>BODY>TMC-</p>	<p>See the Image Fault Sample A-9.</p>
<ul style="list-style-type: none"> An abrupt change occurs in the amount of toner deposited over the entire length of the drum axis when monochrome image is made. It is a 47-mm horizontal line. 	<p>An abrupt change (increase) has occurred in the amount of toner on the photosensitive drum, causing uneven rotation of the drum and, ultimately, a discrepancy in exposure.</p>	<p>Set '1' to the following in service mode: COPIER>OPTION>BODY>BK-</p>	<p>See the Image Fault Sample A-9.</p>
<ul style="list-style-type: none"> A 47-mm horizontal line occurs in the leading edge of paper. 	<p>A yellow pattern made in blank (for progress in image) has occurred uneven rotation of the drum and ultimately, causing a discrepancy in exposure.</p>	<p>Set '2' to the following in service mode: COPIER>OPTION>BODY>TMC-</p>	
<ul style="list-style-type: none"> An abrupt change occurs in the amount of toner deposited over the entire length of the drum axis. It is a 100-mm horizontal line. 	<p>An abrupt change (increase) has occurred in the amount of toner on the intermediate transfer belt, causing uneven rotation of the belt and, ultimately a discrepancy in primary transfer.</p>	<p>Set '2' for the following in service mode: COPIER>OPTION>BODY>Y-PTN.</p>	<p>See the Image Fault Sample A-10.</p> <ul style="list-style-type: none"> adverse effect of setting it to '2': the white area and the image on the paper tend to show a yellowish hue.

Title	Cause	Correction	Remarks
<ul style="list-style-type: none"> • In a high humidity environment, a white spot occurs along the trailing edge of a halftone image on the 2nd side of a double-sided print made after generating a single-sided print and turning on the power (e.g., for the first time in the morning). 	<p>The fixing heat causes the moisture in the paper to evaporate, causing condensation on the delivery guide; if it moves to the leading edge of the 1st side of a double-sided print, a transfer fault will occur along the trailing edge of the 2nd side.</p>	<p>Allow about 10 min between making a single-sided print and making a double-sided print so as to prevent condensation on the delivery guide (thus the symptom).</p>	<p>See the Image Fault Sample A-11.</p>
<ul style="list-style-type: none"> • In a high humidity environment, a white spot occurs along the edge of the paper in a halftone image on the 2nd side of a double-sided print. 	<p>The paper is moist, and tends to become wavy after fixing on its 1st side; as a result, the wavy area prevents proper transfer on the 2nd side and, ultimately, causes a white spot.</p>	<p>Add a cassette heater, or recommend replacement of paper.</p>	<p>See the Image Fault Sample B-1.</p>
<ul style="list-style-type: none"> • A white spot occurs in a print made after power-on (e.g., for the first time in the morning) in a low humidity environment. 	<p>The resistance of the secondary transfer external roller is too low, causing the voltage lower limit limiter to go ON (the level of the secondary transfer current is too high).</p>	<p>With care, make use of the following in service mode: COPIER>ADJUST>HV-TR>2TR-TGT/2TR-SHR/TR-ENV/TR-PPR/TR-CLR/TR-DUP.</p>	<ul style="list-style-type: none"> • adverse effect of changing the setting: toner can move astray, worsening white spots.
<ul style="list-style-type: none"> • A 20 to 30 mm white spot occurs along the trailing edge of prints made on A3 paper. 	<p>The paper arches between the secondary transfer external roller and the fixing roller, and discharge occurs when the trailing edge of the paper leaves the intermediate transfer belt, leaving traces.</p>	<p>Set '1' for the following in service mode: COPIER>OPTION>BODY>FX-SPD.</p>	<p>See the Image Fault Sample B-2.</p> <ul style="list-style-type: none"> • adverse effect of changing the setting: parallel lines may fail to be parallel along the trailing edge.
<ul style="list-style-type: none"> • White spots occur along the trailing edge when dry paper is used (e.g., fresh out of package). 	<p>When the trailing edge of paper moves past the nip area of the secondary transfer external roller, the current flowing to the trailing edge of the paper is limited.</p>	<p>Adjust the setting of the following in service mode: COPIER>ADJUST>BLANK>BLANK-B.</p>	<p>The symptom may be corrected when the trailing edge margin is increased by about 4 mm.</p>

Title	Cause	Correction	Remarks
<ul style="list-style-type: none"> White spots (like small flower) occurs along the leading edge, where the resistance tends to be high in a low humidity environment. 	<ul style="list-style-type: none"> A transfer fault occurs during secondary transfer (i.e., the level of the secondary transfer current is too high). 	<p>With care, make use of the following in service mode:</p> <p>COPIER>ADJUST>HV-TR>2TR-TGT/2TR-SHR/TR-ENV/TR-PPR/TR-CLR/TR-DUP.</p>	<p>See the Image Fault Sample B-3.</p> <ul style="list-style-type: none"> adverse effect of changing the setting: toner may move astray, worsening the occurrence of white spots.
<ul style="list-style-type: none"> A fine, white line occurs around 30 mm of the trailing edge when prints are made on A3 paper. 	<ul style="list-style-type: none"> The temperature at the ends of the fixing roller increases, increasing the pressure on the edges of the roller and, ultimately, causing the trailing edge of paper to snap up. 	<p>Fit a spur (FG6-9649) to the ITB locking shaft.</p>	<p>See the Image Fault Sample B-4.</p>
<ul style="list-style-type: none"> White spots occur in images (mottled). 	<ul style="list-style-type: none"> Paper lint sticks to paper from the pre-registration roller, causing a transfer fault during secondary transfer. 	<p>Clean the clips (2 pc. above the pre-registration roller).</p>	

• **Mounting the Spur (FG6-9649)**

- 1) Slide out the fixing feed unit, and remove the 2 stoppers.
- 2) Mount the spur unit (1) [2] using 2 binding screws (M4×6) [1]. (2 locations at front and rear; F03-307-01)
- 3) Put back the fixing feeder unit.

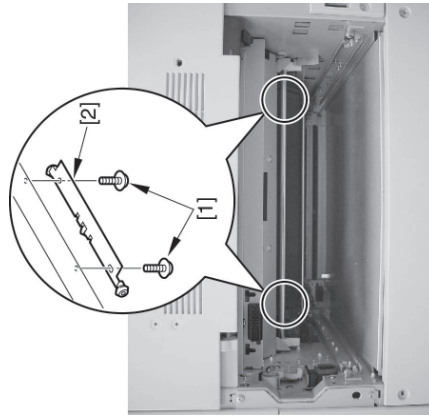

F03-307-01

3.8 The output is soiled/has lines.

Title	Cause	Correction	Remarks
<ul style="list-style-type: none"> Vertical lines (charging roller) occur when the drum unit has been in use for a long time. 	<p>Toner sticks to the charging roller, thus soiling it.</p>	<p>Replace the drum unit of the color in question. (Generate a 16-gradation test pattern (TYPE=4) to identify the color.</p>	<p>See the Image Fault Sample A-12.</p>
<ul style="list-style-type: none"> Vertical lines occur. 	<p>The white plate/mirror of the reader unit is soiled. The copyboard glass is soiled with foreign matter.</p>	<p>Clean the white plate/mirror with lint-free paper moistened with alcohol.</p>	
<ul style="list-style-type: none"> The back of a print made after power-on (e.g., for the first time in the morning) is soiled after making a double-sided print of a halftone image in Bk as the last job of the previous day. 	<p>The surface temperature of the fixing roller has grown too high causing toner to move from paper to the fixing roller; the toner then moves to the surface of the pressure roller, soiling the back of the 1st print made for the first time when the power is turned on the next time.</p>	<p>–</p>	<p>The symptom is limited to 120 mm along the leading edge of the 1st print (on the back; 120 mm being the peripheral length of the pressure roller).</p>
<ul style="list-style-type: none"> Lines occur along the trailing edge when paper of A3 or more is passed. 	<p>Paper arches between the secondary transfer external roller and fixing roller, and discharge occurs when its trailing edge leaves the intermediate transfer belt.</p>	<p>Mount a spur (FG6-9648) to the ITB locking shaft according to the instructions given.</p>	<p>See the Image Fault Sample B-5.</p>
<ul style="list-style-type: none"> A single line occurs in the drum axial direction when a solid image is generated. 	<p>The tube of the fixing roller was inadvertently given a crease during production.</p>	<p>Replace both fixing roller and pressure roller; or, replace the fixing unit.</p>	
<ul style="list-style-type: none"> A black spot occurs (64 mm). 	<p>Foreign matter (non-conductive) exists on the secondary transfer internal roller.</p>	<p>Clean the secondary transfer internal roller.</p>	

• Mounting the Spur (FG6-9648)

- 1) Open the front cover, and shift the intermediate transfer lever to release the unit.
- 2) Slide out the manual feed unit, and take out the right middle cover. (1 screws)
- 3) Release the pattern reader unit (by shifting down the escape lever), and slide out the intermediate transfer unit until the stopper is engaged.



Be sure to slide out the ITB unit; otherwise, you can damage the ITB.

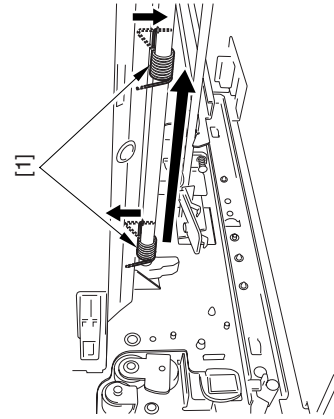

F03-308-01

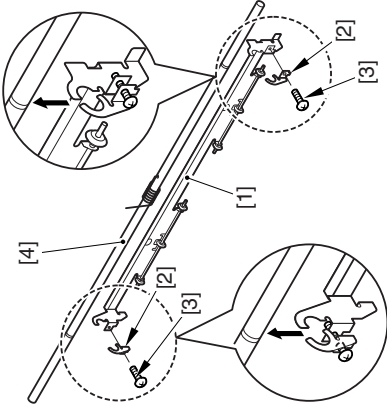

F03-308-02

- 4) Slide out the fixing feeder unit, and remove the 2 stoppers to detach.
- 5) Move the spring [1] found at the rear of the ITB locking shaft from the end of the shaft to the middle; then, secure it in place. (F03-308-01)
- 6) Temporarily fix the mounting plate (front/rear) [2] to the spur unit [1] using a binding screw (M4x8) [3]; then, mount it to the ITB locking shaft [4] as shown. (F03-308-02)
- 7) With your finger, pull the area of tension [1] at the middle of the ITB locking shaft to the front, and hook it on the cut-off [2] in the spur unit. (F03-308-03)
- 8) Fully tighten the screw [2] on the mounting plate at the front and rear. (F03-308-04)
- 9) Put the parts back to their initial positions in the order indicated: steps 4), 3), 2), and 1).

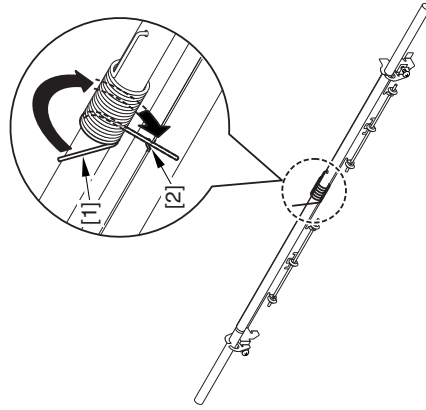

F03-308-03

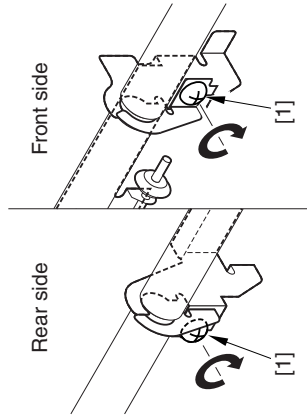

F03-308-04

3.9 The output has a residual image/ghost.

Title	Cause	Correction	Remarks
<ul style="list-style-type: none"> A drum positive ghost occurs in a halftone image after generation of a sensitive drum. solid image. 	<p>A residual charge exists on the photo-sensitive drum.</p>	<p>Set '2' for the following in service mode: COPIER>OPTION>BODY>TMC-SLCT.</p>	
<ul style="list-style-type: none"> A drum reverse ghost occurs in a solid image after generation of a halftone image or an image of white against a black background following the generation of a solid image. 	<p>A residual charge exists on the photo-sensitive drum.</p>	<p>Set '1' or '2' to the following in service mode: COPIER>OPTION>BODY>NEGA-GST.</p>	
<ul style="list-style-type: none"> A slipping ghost occurs after generation of fine lines with a high color ratio. 	<p>Toner remains on the photosensitive drum (from collection of toner to the developing assembly).</p>	<p>Execute the following in user mode: adjust/clean>auto gradation correction>full correction.</p>	

3.10 The output has color displacement.

Title	Cause	Correction	Remarks
<ul style="list-style-type: none"> Color displacement occurs (several mm) in sub scanning direction. 	<p>Toner has stuck to the ITB drive roller, causing the ITB to slip against the ITB drive roller.</p>	<p>Clean the ITB drive roller, tension roller, and secondary transfer internal roller.</p>	<p>See the Image Fault Sample B-6.</p>
<ul style="list-style-type: none"> Parallel lines are not fully parallel along the trailing edge of the 2nd side of an A3 print. 	<p>The relative speed of the fixing roller in relation to the secondary transfer external roller increases to increase the time.</p>	<p>Set '1' for the following in service mode: COPIER>OPTION>BODY>FX-SPD.</p>	<ul style="list-style-type: none"> adverse effect of changing the setting: 20- to 30-mm white spots can occur; image smudges or white spots can worsen along the trailing edge. To correct, mount the spur (FG6-9657).

• **Mounting the Spur (FG6-9657)**

- Slide out the fixing feeder unit, and remove the 2 stoppers to detach.
- Using 2 binding screws (M4x6) [1], mount the spur unit (2) [2]. (2 locations, front and rear; F03-310-01)
- Put the fixing feeder unit back into its initial position.

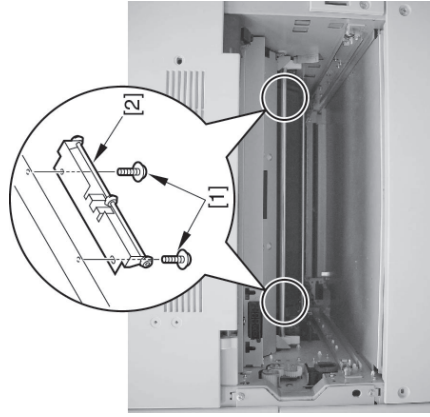

F03-310-01

3.11 The output has poor color reproduction.

Troubleshooting Volume>Chapter 3 Troubleshooting Image/Operation Faults>1.6 Checking the Units and Functional Block

3.12 The output has smears/traces. (rub-off)

Title	Cause	Correction	Remarks
<ul style="list-style-type: none"> Traces of the delivery roller appear when an image with a high color ratio is printed on thick paper (particularly, coated paper). 	<p>The wax used in the paper is cooled by the roller and caused to cake.</p>	-	<p>See the Image Fault Sample A-13. A correction of the fault is expected to start in February 2003 on a running-change basis.</p>
<ul style="list-style-type: none"> Traces of the pickup roller occur along the leading edge of a transparency when the source of the transparency is the cassette. 	<p>When a stack of transparencies is used, the leading edge of the bottom transparency is subjected to friction at time of pickup, thus causing it to develop a scratch.</p>	<p>Fan out the stack before placing it to correct the fault. Recommend the use of manual feeding.</p>	<p>See the Image Fault Sample A-14.</p>
<ul style="list-style-type: none"> Traces of the pickup roller occur in Bk solid images printed on moist paper. 	<p>The moisture content of the area coming into contact with the pickup roller is low, showing a resistance higher than the areas with a higher moisture content.</p>	<p>Add a cassette heater and/or internal sheet.</p>	<p>See the Image Fault Sample A-15.</p>
<ul style="list-style-type: none"> A rub-off occurs along the trailing edge of A3 paper. 	<p>The temperature at the ends of the fixing roller increases to increase the pressure on the edges, thus causing the trailing edge of paper to suffer friction again the ITB when it leaves the secondary transfer external roller.</p>	<p>Mount a spur (FG6-9648) to the ITB locking shaft as indicated.</p>	<p>See the image Fault Sample B-7.</p>

4 Feed Faults

4.1 Multiple Feed

- Troubleshooting Volume>Chapter 3 Troubleshooting Image/Operation Faults>1.6 Checking Units and Functional Blocks

Title	Cause	Correction	Remarks
• Multiple transparencies are moved at the same time.	The transparencies are attracted to each other by the work of static charge.	Fan out the transparencies.	
• Multiple sheets of gloss paper, tracing paper, or some thick paper are moved at the same time.	The bonding between sheets is too strong, causing the separation mechanism to fail.	Recommend the use of the manual feed tray, feeding the sheets individually.	Types of media in question: gloss paper (coated), tracing paper, and thick paper.

4.2 Skew Movement

- Troubleshooting Volume>Chapter 3 Troubleshooting Image/Operation Faults>1.6 Checking Units and Functional Blocks

4.3 Bend/Tear

- Troubleshooting Volume>Chapter 3 Troubleshooting Image/Operation Faults>1.6 Checking Units and Functional Blocks

4.4 Wrinkle

- Troubleshooting Volume>Chapter 3 Troubleshooting Image/Operation Faults>1.6 Checking Units and Functional Blocks

Title	Cause	Correction	Remarks
• Paper tends to wrinkle when there are only few sheets remaining in the cassette at time of pickup in a high humidity environment.	The paper is likely to be moist, thus tending to become wavy.	Add a cassette internal sheet.	

4.5 Wave/Curl

- Troubleshooting Volume>Chapter 3 Troubleshooting Image/Operation Faults>1.6 Checking the Units and Functional Blocks

Title	Cause	Correction	Remarks
<ul style="list-style-type: none"> • The medium tends to wave or curl if stacking is poor, as when the medium is of high rigidity and used in a high humidity environment. 	The medium absorbs moisture, and tends to curl appreciably downward.	Set '1' for the following in service mode: COPIER>OPTION>BODY>DEVL- FAN	

5 Operating Faults

5.1 The machine fails to go ON.

- Troubleshooting Volume>Chapter 3 Troubleshooting Image/Operation Faults>1.6 Checking the Units and Functional Blocks

5.2 Control Panel-Related

- Troubleshooting Volume>Chapter 3 Troubleshooting Image/Operation Faults>1.6 Checking the Units and Functional Blocks

5.3 Malfunction/Wrong Detection

- Troubleshooting Volume>Chapter 3 Troubleshooting Image/Operation Faults>1.6 Checking the Units and Functional Blocks

5.4 Abnormal Noise

- Troubleshooting Volume>Chapter 3 Troubleshooting Image/Operation Faults>1.6 Checking the Units and Functional Blocks

6 Jams



To check a specific part, use the following service mode to turn it on: COPIER>FUNCTION>PART-CHK. In the case of malfunction, be sure that its connection to the DC controller PCB is correct.

6.1 Pickup Unit

- Troubleshooting Volume>Chapter 3 Troubleshooting Image/Operation Faults>1.6 Checking the Units and Functional Blocks

	Parts to check	Remarks
Cassette pickup jam	Cassette 1 pickup motor (M6)	
	Cassette 2 pickup motor (M7)	
	Cassette 1 pickup solenoid (SL3)	
	Cassette 2 pickup solenoid (SL4)	
Manual feed pickup jam	Pre-registration motor (M9)	
	Manual feed pickup solenoid (SL1)	
	Fault in torque mechanism of manual feed separation roller	
	Dirt/deformation of separation sheet in manual feed tray	

6.2 Registration Unit

- Troubleshooting Volume>Chapter 3 Troubleshooting Image/Operation Faults>1.6 Checking the Units and Functional Blocks

	Parts to check	Remarks
Registration unit jam	Registration motor (M8) Pre-registration motor (M9) Registration sensor (PS26)	For the registration sensor, be sure to use the following setting mode to check its operation: COPIER>I/O>DC-CON>P007.
	Check to see if the clip of the pre-registration roller moves smoothly.	

6.3 Fixing Feeder Unit

- Troubleshooting Volume>Chapter 3 Troubleshooting Image/Operation Faults>1.6 Checking the Units and Functional Blocks

Title	Cause	Correction	Remarks
• The leading edge of paper tends to resist separation in a high humidity environment and when the image has a high color ratio.	The rigidity of paper is too low so that it tends to wrap around the fixing roller, preventing it from separating from the roller at time of delivery.	Add a cassette heater.	
	Fixing inlet jam	Fixing motor (M24)	Remarks
	Fixing delivery jam	Delivery path switching solenoid 2 (SL5)	

6.4 Delivery Vertical Path Unit

- Troubleshooting Volume>Chapter 3 Troubleshooting Image/Operation Faults>1.6 Checking the Units and Functional Blocks

Parts to check	Remarks
Delivery vertical path jam	
Delivery vertical path motor (M10)	
Face-down delivery motor (M11)	

6.5 Duplex Unit

- Troubleshooting Volume>Chapter 3 Troubleshooting Image/Operation Faults>1.6 Checking the Units and Functional Blocks

Parts to check	Remarks
Duplex unit jam	
Duplex registration sensor (PS21)	For the sensor, be sure to use
Duplet pickup sensor (PS24)	the following service mode to
Duplex registration clutch (CL1)	check its operation:
Duplex pickup clutch (CL2)	COPIER>I/O>DC-CON>
Duplex feed motor (M26)	P007.

7 Arrangement and Functions of Electrical Parts

7.1 Clutches and Solenoid

7.1.1 Reader Unit

The reader unit has no clutch or solenoid.

7.1.2 Printer Unit

Item	Notation	Name	Description
Clutch	CL1	duplex registration clutch	matches the position of images on double-sided prints.
	CL2	duplex pickup clutch	controls the timing of pickup for double-sided printing.
Solenoid	SL1	manual feed pickup solenoid	controls the timing of pickup for the manual feed block.
	SL2	delivery path switching solenoid 1	switches over positions of the delivery tray.
	SL3	cassette 1 pickup solenoid	controls the timing of pickup from the cassette 1.
	SL4	cassette 2 pickup solenoid	controls the timing of pickup from the cassette 2.
	SL5	delivery path switching solenoid 2	switches over the paths in the delivery/feeder unit.

T03-701-01

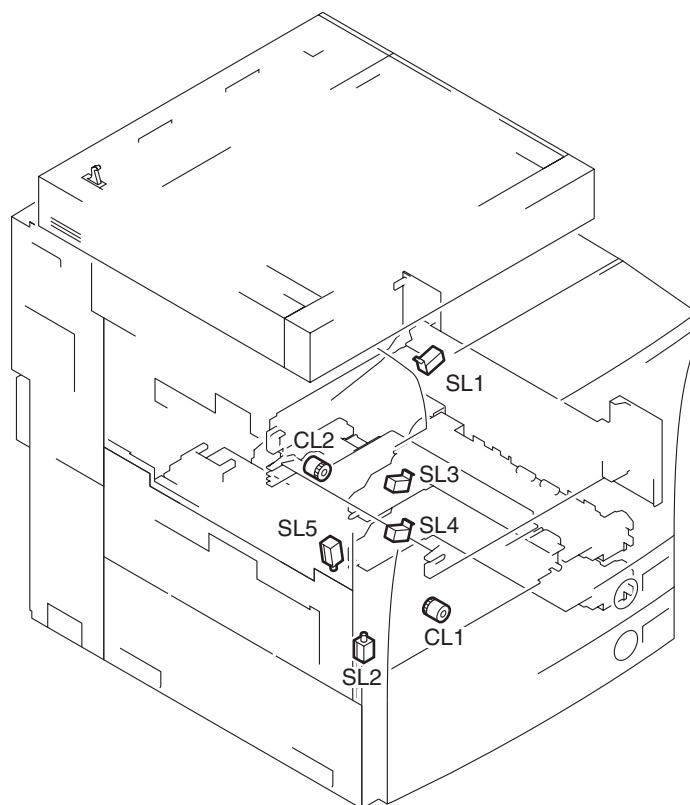

F03-701-01

7.2 Motor

7.2.1 Reader Unit

Item	Notation	Name	Description
Motor	M1	scanner motor	drives the scanner system.

T03-702-01

7.2.2 Printer Unit

Item	Notation	Name	Description
Motor	M1	drum ITB motor	drives the drum/intermediate transfer unit.
	M2	laser scanner motor (Y)	drives the laser scanner (Y).
	M3	laser scanner motor (M)	drives the laser scanner (M).
	M4	laser scanner motor (C)	drives the laser scanner (C).
	M5	laser scanner motor (Bk)	drives the laser scanner (Bk).
	M6	cassette 1 pickup motor	drives the pickup unit 1.
	M7	cassette 2 pickup motor	drives the pickup unit 2.
	M8	registration motor	drives the registration roller.
	M9	pre-registration motor	drives the pre-registration roller.
	M10	delivery vertical path motor	drives the delivery vertical path roller 2.
	M11	face-down delivery motor	drives the delivery vertical path roller 1.
	M12	developing motor (Y)	drives the developing unit (Y).
	M13	developing motor (M)	drives the developing unit (M).
	M14	developing motor (C)	drives the developing unit (C).
	M15	developing motor (Bk)	drives the developing unit (Bk).
	M16	image slope correction motor (Y)	corrects image slope (Y).
	M17	image slope correction motor (M)	corrects image slope (M).
	M18	image slope correction motor (C)	corrects image slope (C).
	M19	image slope control motor (Bk)	corrects image slope (Bk).
	M20	toner container motor (Y)	stirs toner inside the toner container (Y).
	M21	toner container motor (M)	stirs toner inside the toner container (M).
	M22	toner container motor (C)	stirs toner inside the toner container (C).
	M23	toner container motor (Bk)	stirs toner inside the toner container (Bk).
	M24	fixing motor	drives the fixing unit.
	M25	horizontal registration motor	matches the horizontal registration position for paper.
	M26	duplex feeder motor	moves paper to the duplex unit.

T03-702-02

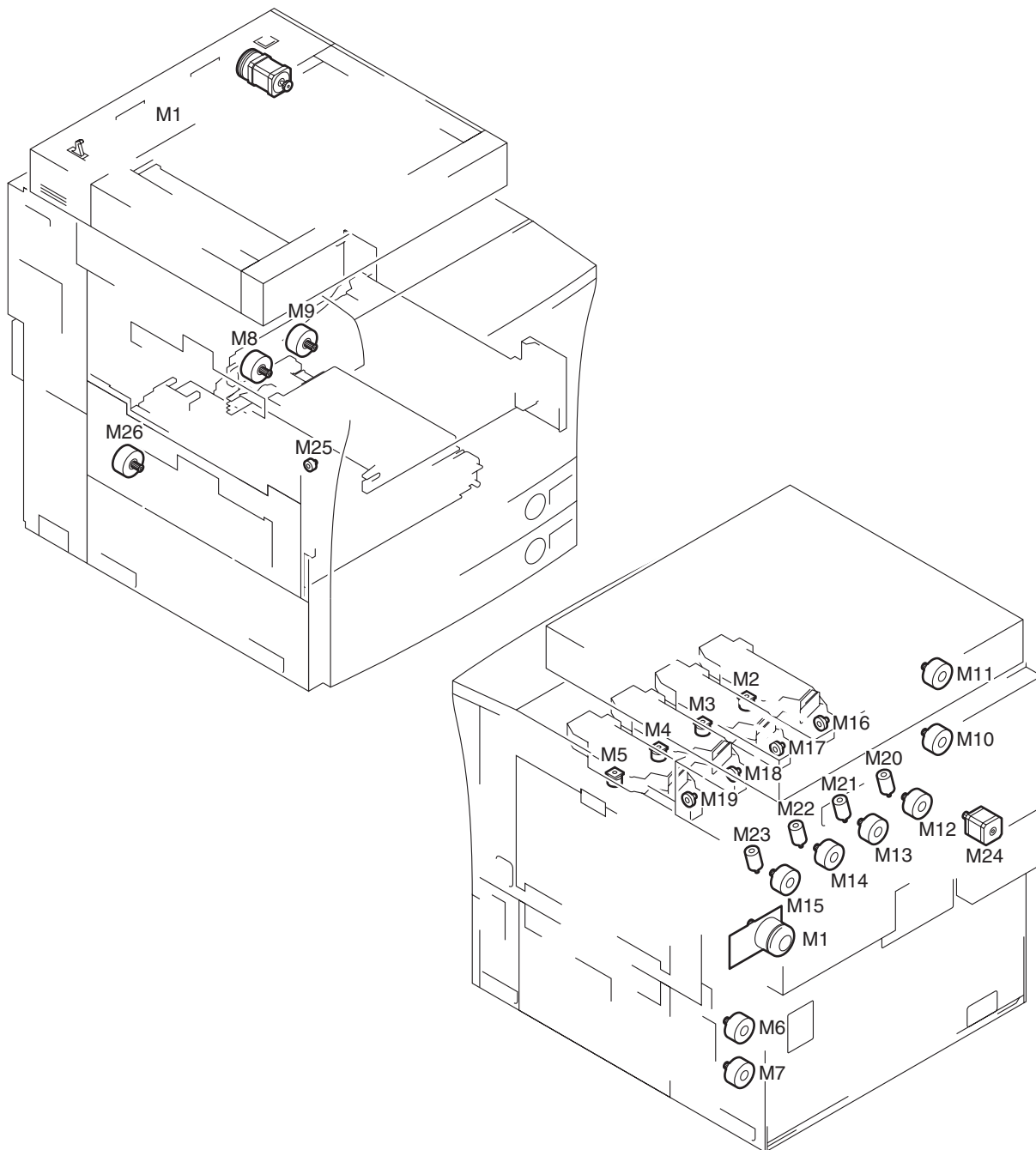

F03-702-01

7.3 Fans

7.3.1 Reader Unit

The reader unit does not have fans.

7.3.2 Printer Unit

Item	Notation Name	Description	
Fan	FM1	power supply cooling fan	cools the power supply unit.
	FM2	fixing heat discharge fan	discharges heat from the fixing unit.
	FM3	machine heat discharge fan	discharges heat from inside the machine.
	FM4	cleaner fan	limits overheating inside the machine.
	FM5	delivery cooling fan	cools paper for delivery.
	FM6	manual feed cooling fan	cools paper for manual feeding.
	FM7	controller fan	cools the inside of the controller box.
	FM8	delivery vertical path cooling fan	cools paper at vertical path for delivery.

T03-703-01

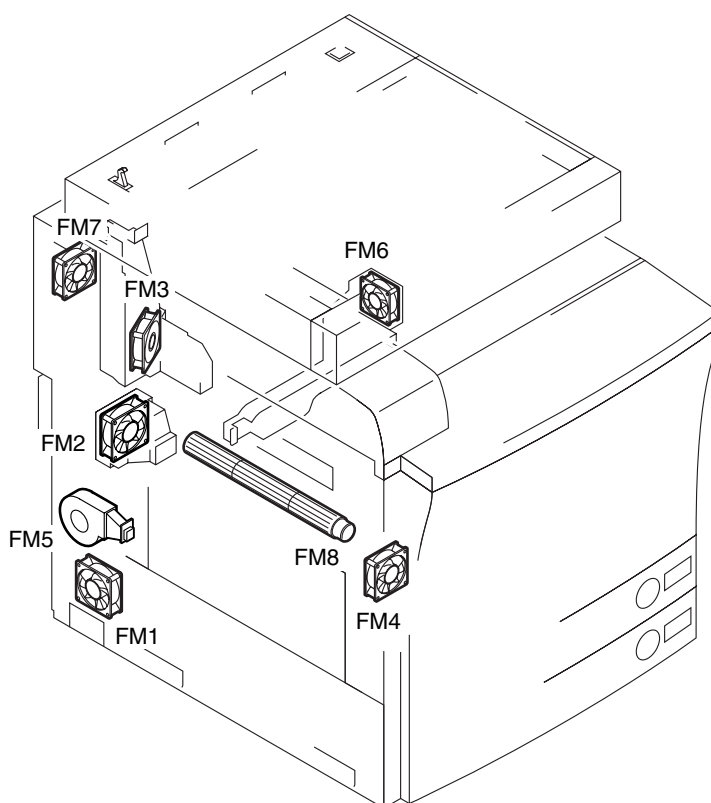

F03-703-01

7.4 Sensors

7.4.1 Reader Unit

Item	Notation	Name	Description
Sensor	CF1	original size sensor	detects original size.
	CF2	original size sensor	detects original size.
	SR1	copyboard cover sensor	detects the state (open/closed) of the copyboard cover.
	SR2	home position sensor	detects the home position of the scanner.

T03-704-01

7.4.2 Printer Unit

Item	Notation	Name	Description
Sensor	PS1	toner feedscrew rotation sensor (Y)	detects the rotation of the feedscrew inside the toner container (Y).
	PS2	toner feedscrew rotation sensor (M)	detects the rotation of the feedscrew inside the toner container (M).
	PS3	toner feedscrew rotation sensor (C)	detects the rotation of the feedscrew inside the toner container (C).
	PS4	toner feedscrew rotation sensor (Bk)	detects the rotation of the feedscrew inside the toner container (Bk).
	PS5	fixing feeder unit open/closed sensor	detects the state (open/closed) of the fixing feeder unit.
	PS6	face-down delivery sensor 2	detects the passage of paper in the face-down delivery assembly.
	PS7	cassette 1 paper sensor	detects the presence/absence of paper inside the cassette 1.
	PS8	center delivery tray full sensors	detects the state (full of paper) inside the face-down delivery assembly.
	PS9	manual feed last paper sensor	detects paper in the manual feed unit.
	PS10	manual feed paper sensor	detects paper in the manual feed unit.
	PS11	pickup vertical path cover open/closed sensor	detects the state (open/closed) of the pickup vertical path cover.
	PS12	face-down delivery sensor 1	detects face-down delivery.
	PS13	delivery vertical path cover open/closed sensor	detects the state (open/closed) of the delivery vertical path cover.
	PS14	cassette 1 paper level sensor (A)	detects the level of paper inside the cassette 1 (A)
	PS15	cassette 1 paper level sensor (B)	detects the level of paper inside the cassette 1 (B)
	PS16	cassette 1 retry paper sensor	detects paper retry operation for the cassette 1
	PS17	cassette 2 retry paper sensor	detects paper retry operation for the cassette 2

T03-704-02

Item	Notation	Name	Description
Sensor	PS18	cassette 2 paper level sensor (B)	detects the level of paper inside the cassette 2 (B)
	PS19	cassette 2 paper sensor	detects the presence/absence of paper inside the cassette 2.
	PS20	cassette 2 paper level sensor (A)	detects the level of paper inside the cassette 2 (B)
	PS21	duplex registration sensor	detects double-sided registration.
	PS22	duplex horizontal registration sensor	detects the position of paper in sub scanning direction.
	PS23	front cover open/closed sensor	detects the state (open/closed) of the front cover.
	PS24	duplex pickup sensor	detects pickup from the duplex unit.
	PS25	fixing delivery sensor	detects delivery in the fixing unit.
	PS26	registration sensor	detects paper before registration.
	PS27	fixing inlet sensor	detects movement of paper to the fixing unit.
	PS28	manual feed unit open/closed sensor	detects the state (open/closed) of the manual feed unit.
	VR1	slide resistor	detects the width of paper for manual feed.
	OHP1	transparency sensor (front)	detects a transparency.
	OHP2	transparency sensor (rear)	detects a transparency.
	EV1	environment sensor	environment sensor
	TH1	fixing main thermistor	detect the temperature in the middle of the fixing roller.
	TH2	fixing sub thermistor	detects the temperature at the ends of the fixing roller.
	TP1	fixing thermal switch	detects the temperature at the ends of the fixing roller.
	TPS1	SALT sensor	stabilizes development characteristics (SALT).
	TS1	ATR sensor (Y)	executes automatic toner density correction (ATR; Y)
	TS2	ATR sensor (M)	executes automatic toner density correction (ATR; M)
	TS3	ATR sensor (C)	executes automatic toner density correction (ATR; C)
	TS4	ATR sensor (Bk)	executes automatic toner density correction (ATR; Bk)

T03-704-03

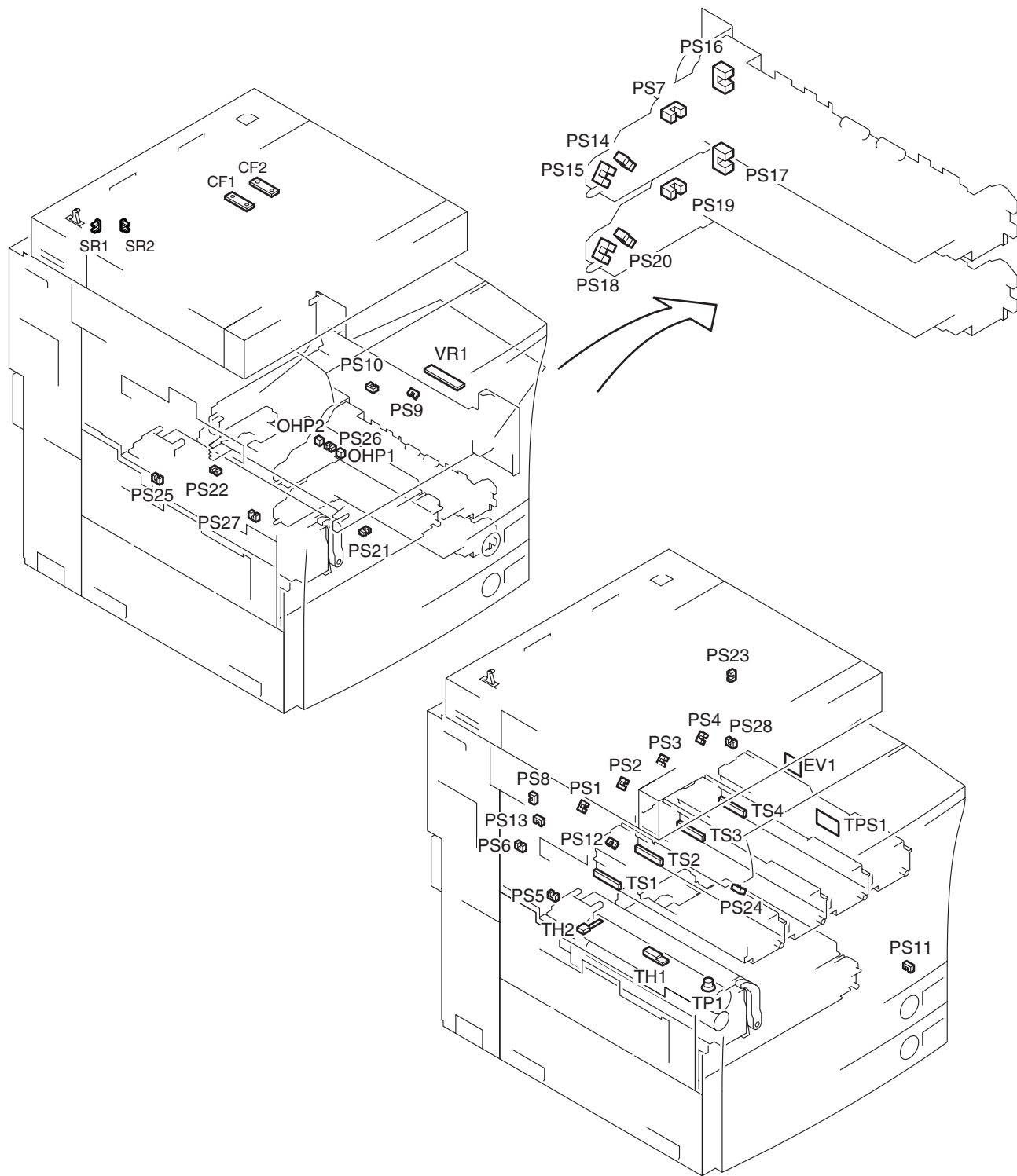

F03-704-01

7.5 Switches

7.5.1 Reader Unit

The reader unit does not have switches.

7.5.2 Printer Unit

Item	Notation	Name	Description
Switch	SW1	main power switch	turns on/off the main power.
	SW2	cassette 1 size detecting switch	detects the size of paper inside the cassette 1.
	SW3	cassette 2 size detecting switch	detects the size of paper inside the cassette 2.
	MSW1	front cover open/closed detection switch 1	detects the state (open/closed) of the front cover.
	MSW2	front cover open/closed detection switch 2	detects the state (open/closed) of the front cover.
	MSW3	manual feed unit open/closed detection switch 1	detects the state (open/closed) of the manual feed unit.
	MSW4	manual feed unit open/closed detection switch 2	detects the state (open/closed) of the manual feed unit.
	MSW5	fixing feeding unit open/closed detection switch 1	detects the state (open/closed) of the fixing feeder unit.
	MSW6	fixing feeding unit open/closed detection switch 2	detects the state (open/closed) of the fixing feeder unit.

T03-705-01

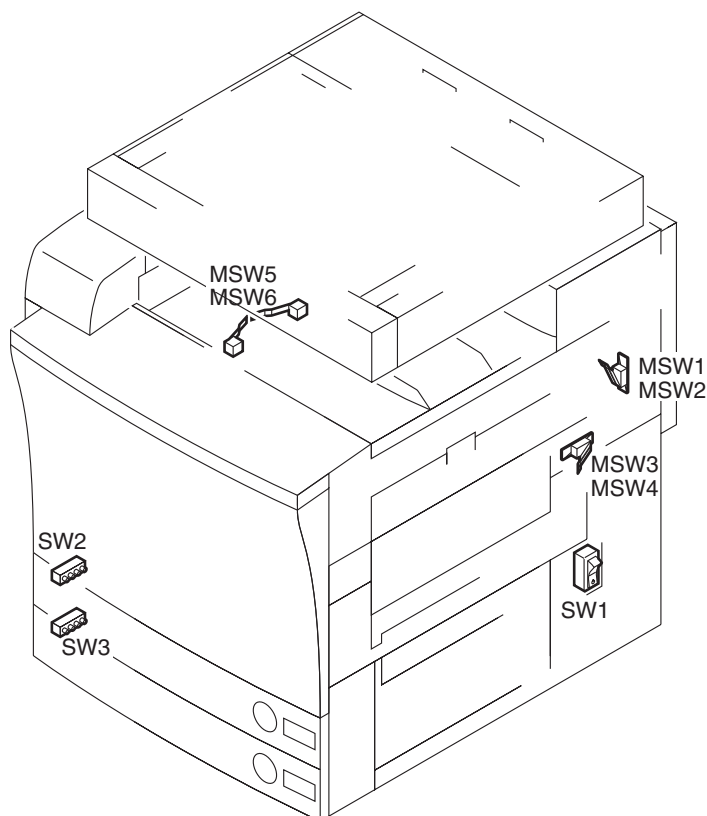

F03-705-01

7.6 Lamps, Heaters, and Others

7.6.1 Reader Unit

Item	Notation	Name	Description
Lamp	LA1	scanning lamp	illuminates an original.
Heater	H1	anti-condensation heater	prevents condensation on a mirror.
	H2	anti-condensation heater	prevents condensation on a lens.

T03-706-01

7.6.2 Printer Unit

Item	Notation	Name	Description
Heater	H1	fixing main heater	main heater (controls the temperature of the fixing roller)
	H2	fixing sub heater	sub heater (controls the temperature of the fixing roller)
	H3	fixing heat retaining heater	heat retaining heater (keeps the pressure roller heated)
	H4	cassette heater	prevents absorption of moisture by paper inside the cassette.
Breaker	ELCB1	leakage breaker	leakage breaker
Power cord	PLG1	power cord	power cord
Speaker	SP1	speaker	speaker

T03-706-02

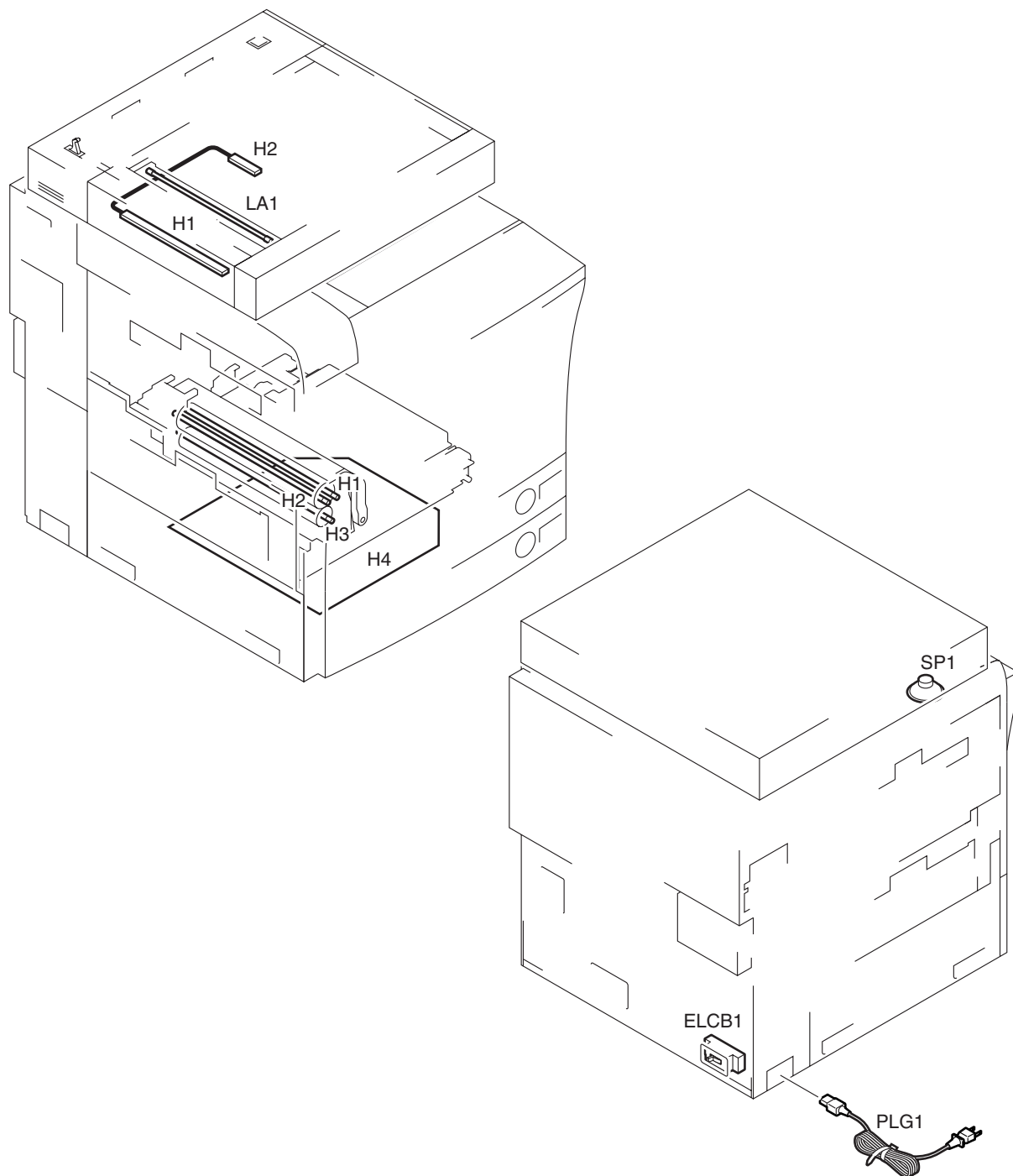

F03-706-01

7.7 PCBs

7.7.1 Reader Unit

Ref.	Name	Description
[1]	reader controller PCB	controls the reader unit/ADF.
[2]	interface PCB	communicates image information read by the reader unit to the printer unit.
[3]	inverter PCB	controls the scanning lamp.
[4]	CCD/AP PCB	drives the CCD/processes analog images.
[5]	fuse PCB	controls mirrors/lens heater.

T03-707-01

7.7.2 Printer Unit

Ref.	Name	Description
[6]	DC controller PCB	controls the printer unit/options.
[7]	laser driver PCB (Y)	controls the drive of the laser unit (Y).
[8]	laser driver PCB (M)	controls the drive of the laser unit (M).
[9]	laser driver PCB (C)	controls the drive of the laser unit (C).
[10]	laser driver PCB (Bk)	controls the drive of the laser unit (Bk).
[11]	BD detection PCB (Y)	detects the laser beam (Y).
[12]	BD detection PCB (M)	detects the laser beam (M)
[13]	BD detection PCB (C)	detects the laser beam (C).
[14]	BD detection PCB (Bk)	detects the laser beam (Bk).
[15]	waste toner detection PCB (light-emitting)	detects the level of toner inside the waste toner container.
[16]	waste toner detection PCB (light-receiving)	detects the level of toner inside the waste toner container.
[17]	auto registration sensors F (light-emitting) detection PCB	reads the image position correction pattern.
[18]	auto registration sensor F (light-receiving) detection PCB	reads the image position correction pattern.
[19]	auto registration sensors R (light-emitting) detection PCB	reads the image position correction pattern.
[20]	auto registration sensor R (light receiving) detection PCB	reads the image position correction pattern.
[21]	duplex driver PCB	controls the sensors and motors inside the duplex unit.
[22]	microswitch PCB	detects the state (open/closed) of the manual feed unit/front cover.
[23]	DC power supply PCB (1)	supplies DC power.
[24]	DC power supply PCB (2)	supplies DC power.

T03-707-02

Ref.	Name	Description
[25]	fuse PCB	distributes voltage supplied by the DC power unit; communicates with the controller unit/ DC controller PCB.
[26]	heater control PCB	controls the main heater.
[27]	HV1 PCB	controls charging/development.
[28]	HV2 PCB	controls primary transfer.
[29]	HV1-SUB PCB	detects charging AC current; controls development AC output; distributes signals; facilitates upstream operations; facilitates downstream operations.
[30]	HV2-SUB PCB	controls power input.
[31]	HV3 PCB	controls secondary transfer.
[32]	HV4 PCB	facilitates upstream operations. (transmission to HV1)
[33]	relay PCB 1	reads information from memory inside the drum unit.
[34]	cassette heater PCB	controls the cassette heater.
[35]	power distribution PCB	relays power to PCBs.
[36]	ECO-ID PCB	facilitates image processing.
[37]	control key PCB	control key
[38]	main controller PCB (main)	processes output image sent to the printer unit.
[39]	main controller PCB (sub)	processes conversion input image data from the reader unit.
[40]	differential PCB	converts signals from the reader unit.
[41]	control panel CPU PCB	controls the control panel.
[42]	control panel KEY PCB	controls the input information from the keypad.
[43]	control panel inverter PCB	turns on/off the LCD backlight.

T03-707-03

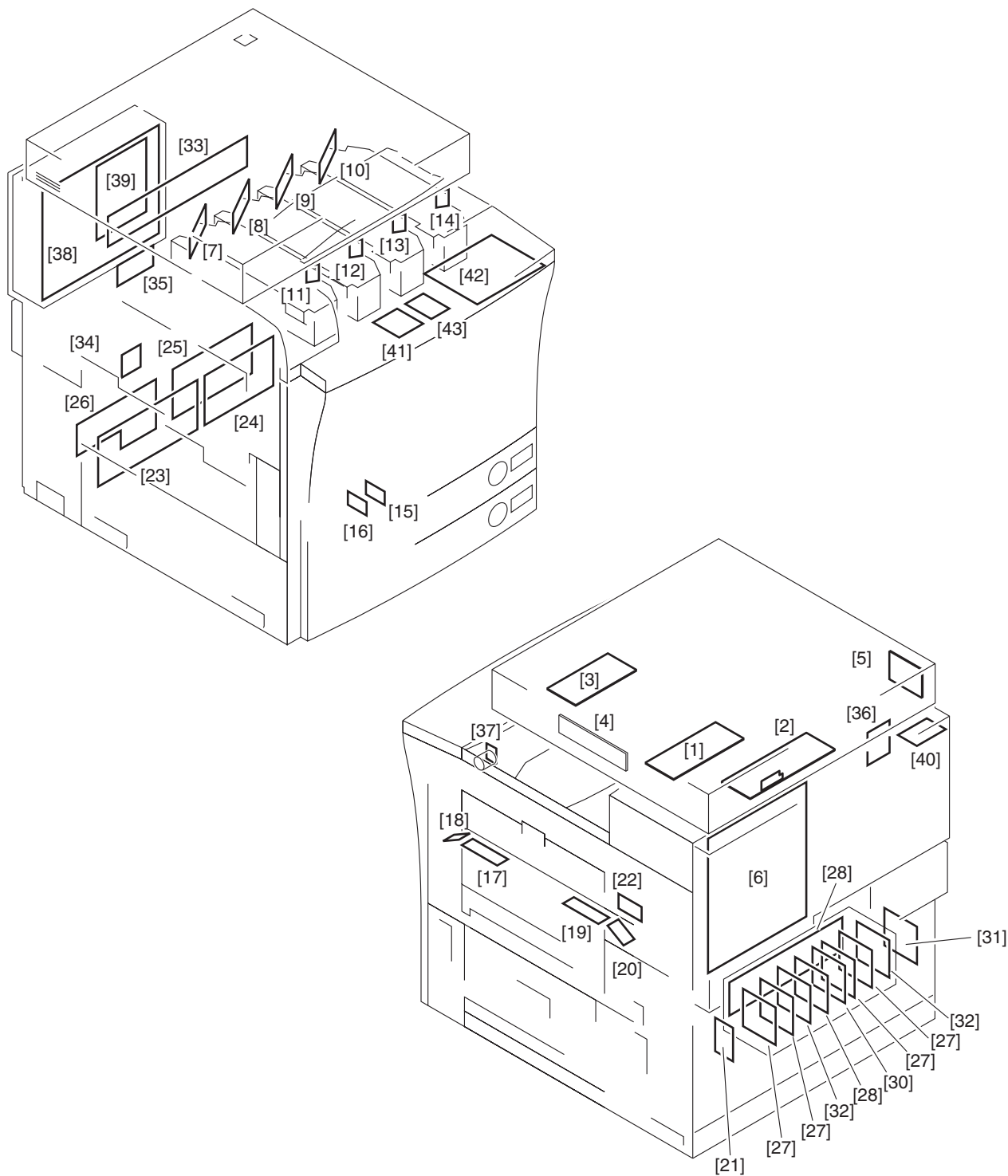

F03-707-01

7.8 2-Cassette Pedestal-X1

Item	Notation	Name	Description
Motor	M51	cassette 3 pickup motor	drives the pickup unit 3.
	M52	cassette 4 pickup motor	drives the pickup unit 4.
Sensor	PS51	cassette 3 paper level sensor (A)	detects the level of paper inside the cassette 3 (A).
	PS52	cassette 3 paper level sensor (B)	detects the level of paper inside the cassette 3 (B).
	PS53	cassette 3 retry paper sensor	detects pickup retry operation for the cassette 3.
	PS54	cassette 3 paper sensor	detects the presence/absence of paper inside the cassette 3.
	PS55	cassette 4 paper level sensor (A)	detects the level of paper inside the cassette 4 (A).
	PS56	cassette 4 paper level sensor (B)	detects the level of paper inside the cassette 4 (B).
	PS57	cassette 4 retry paper sensor	detects pickup retry operation for the cassette 4.
	PS58	cassette 4 paper sensor	detects the presence/absence of paper inside the cassette 4.
	PS59	right cover open/closed sensor	detects the state (open/closed) of the right cover.
Solenoid	SL51	cassette 3 pickup solenoid	controls the timing of pickup from the cassette 3.
	SL52	cassette 4 pickup solenoid	controls the timing of pickup from the cassette 4.
Switch	SW51	cassette 3 size detecting switch	detects the size of paper inside the cassette 3.
	SW52	cassette 4 size detecting switch	detects the size of paper inside the cassette 4.
	SW53	cassette heater switch	turns on/off the cassette heater.
Heater	H51	cassette heater	prevents absorption of moisture by paper inside the cassette.
PCB	[1]	pedestal controller PCB	controls the cassette pedestal.
	[2]	power supply PCB	supplies power.
	[3]	cassette heater PCB	controls the cassette heater.

T03-708-02

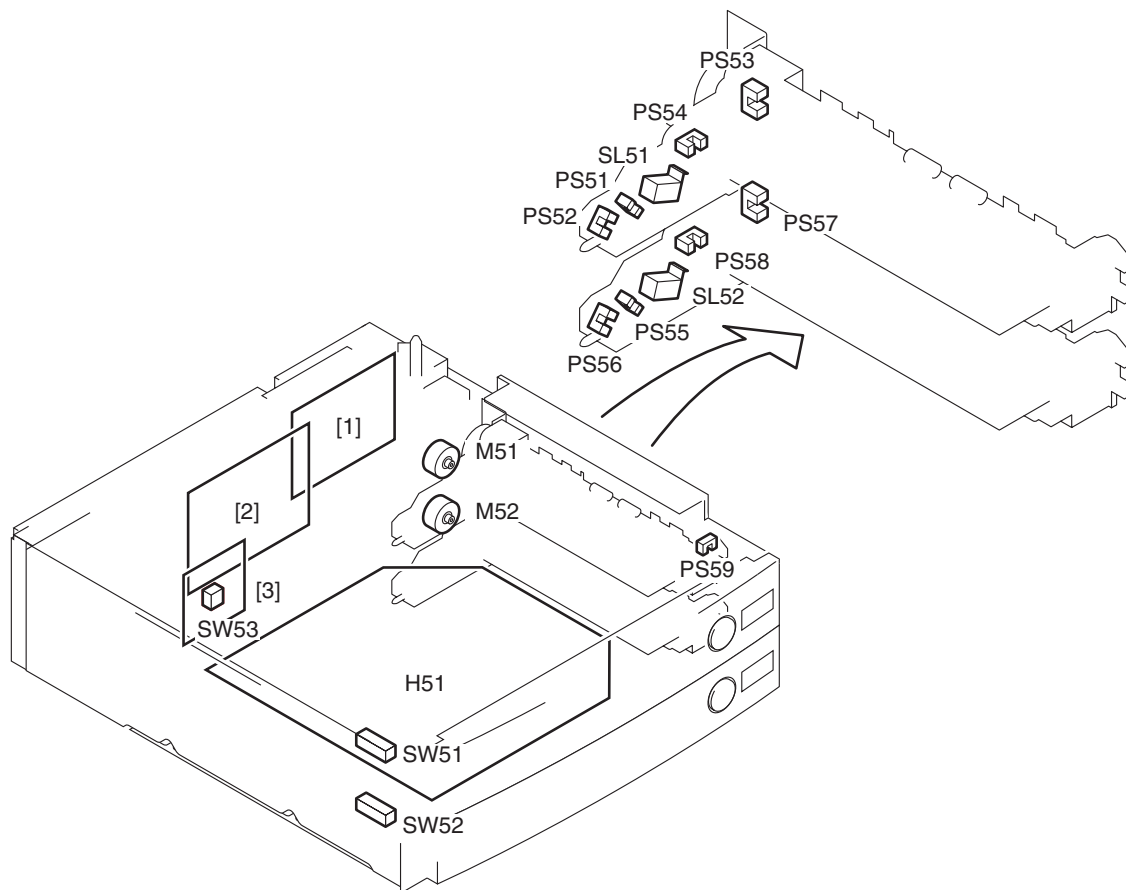

F03-708-01

7.9 Plain Pedestal-C1

Name	Ref.	Description
PCB	[1] pedestal controller PCB	controls the pedestal.
	[2] power supply PCB	supplies power.

T03-709-01

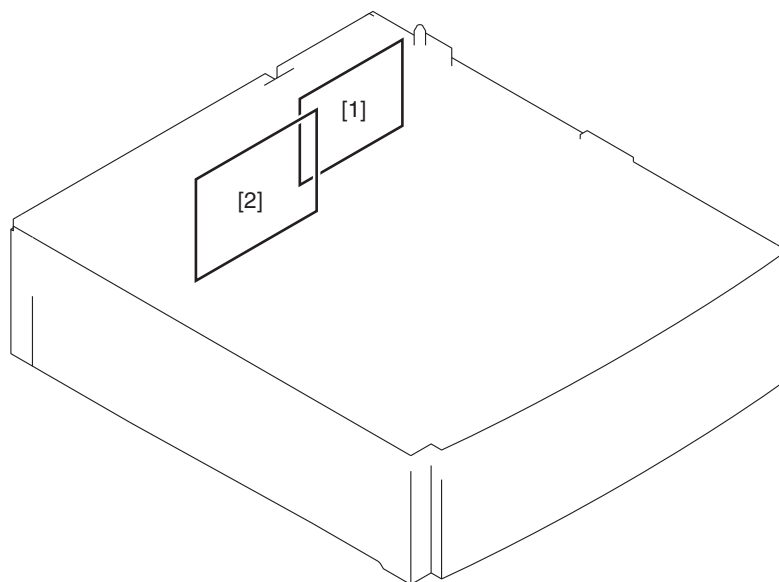

F03-709-01

8 Variable Resistors (VR), Light-Emitting Diodes (LED), and Check Pins by PCB

Of the resistors (VR), light-emitting diodes (LED), and check pins used in the machine, those needed in servicing the machine in the field are discussed:



Those VRs and check pins that are not found in the lists are designed exclusively for use at the factory, requiring special tools and measuring instruments. Do not touch them in the field.



Some LEDs permit flow of current when OFF; this is a normal condition, and must be kept in mind.



-
- ⦿..... VRs that may be used in the field.
 - ⊘..... VRs that must not be used in the field.
-

8.1 Main Controller PCB (main)

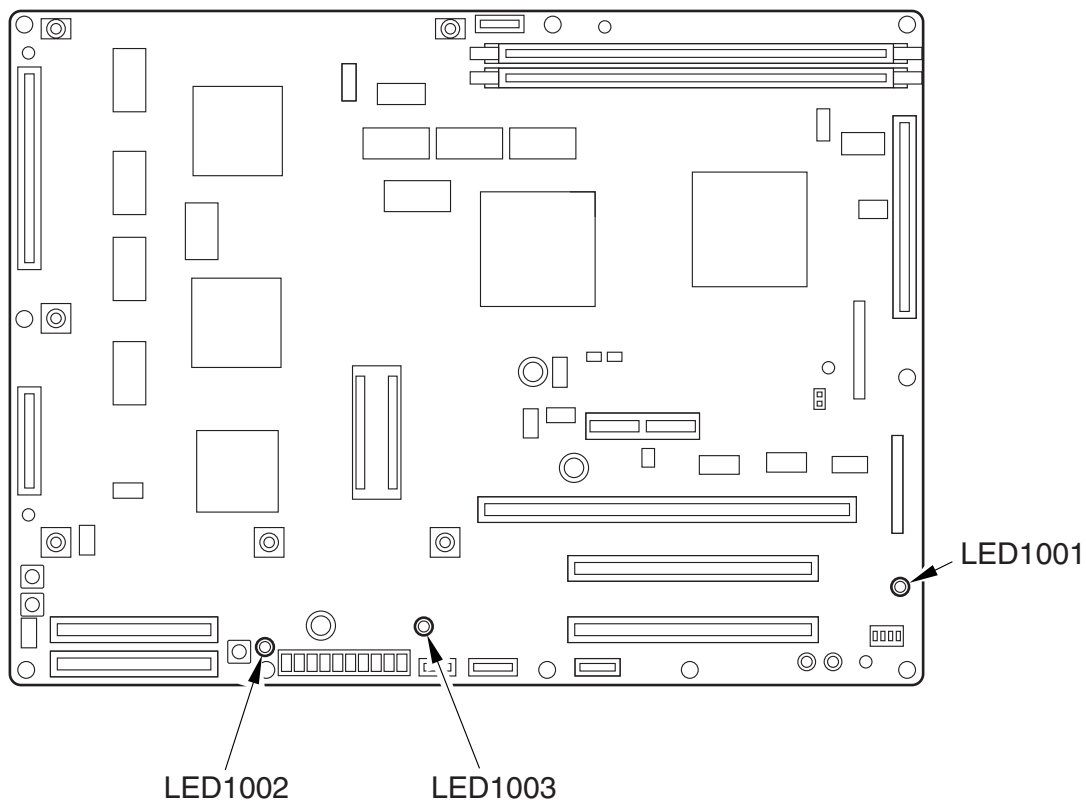

F03-801-01

Notation	Description
LED1001	in operation
LED1002	+3.3V (non-all night) being supplied
LED1003	+3.3V (all-night) being supplied

8.2 Main Controller PCB (sub)

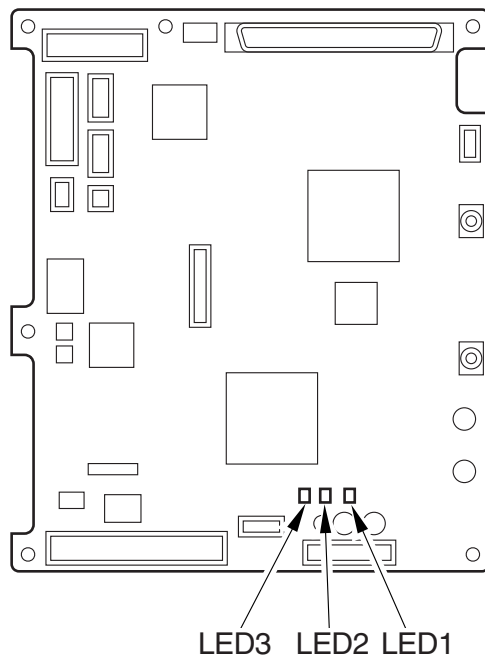

F03-802-01

Notation	Description
LED1	+3.3V (all-nigh) being supplied
LED2	+3.3V (non-all night) being supplied
LED3	+5V (non-all night) being supplied

8.3 Reader Controller PCB

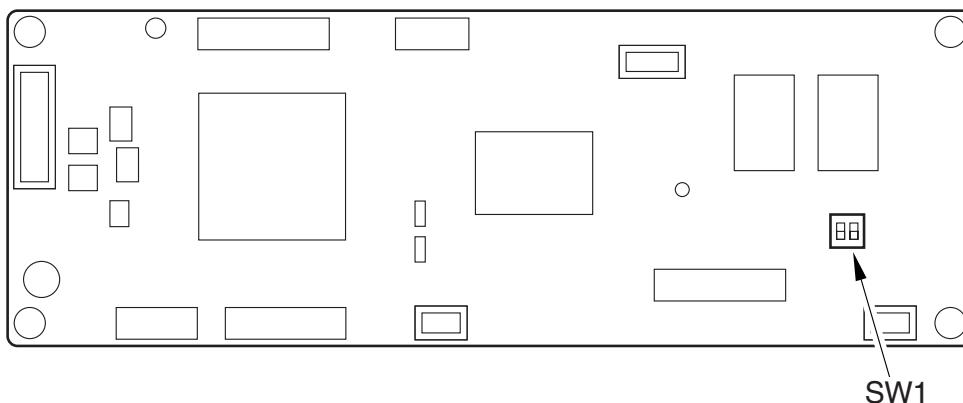

F03-803-01

Notation	Description
SW1	selects paper configuration for original size detection

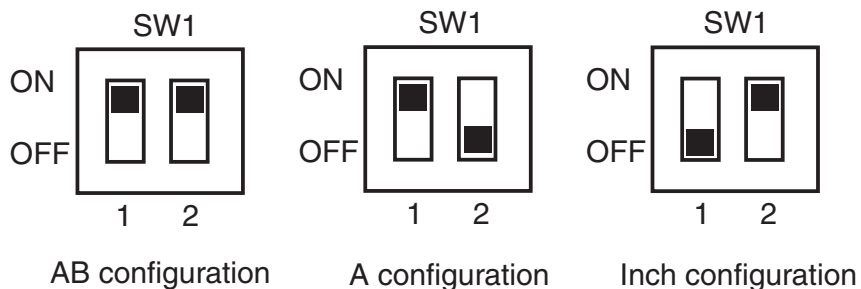

F03-803-02

8.4 Inverter PCB

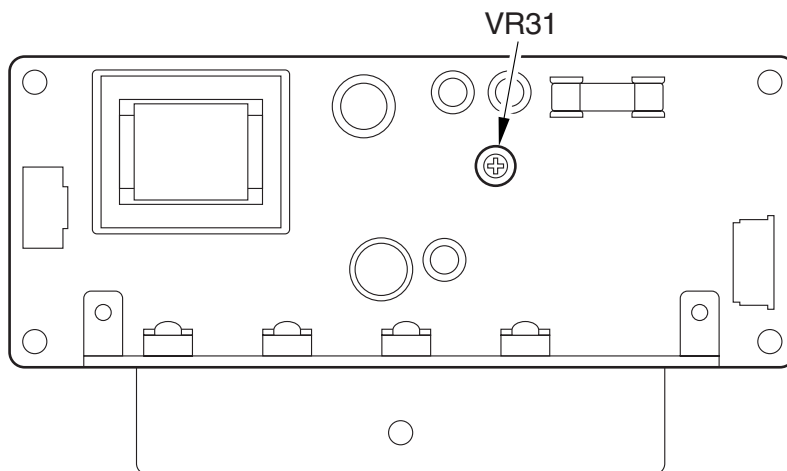

F03-804-01

Notation	Description
VR31	for factory

8.5 Differential PCB

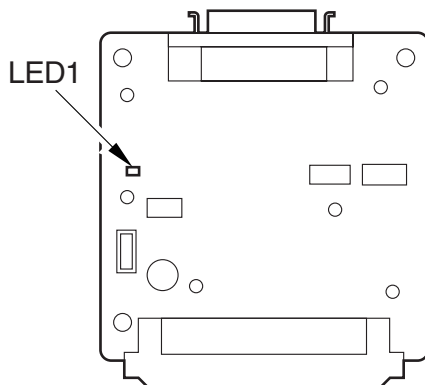

F03-805-01

Notation	Description
LED1	+3.3V (non-all night) being supplied

CHAPTER 4

SELF DIAGNOSIS

1 Error Code

The machine is equipped with a mechanism to check its state (particularly of its sensors) and indicate the nature of a fault, if any, in the form of an error code on its control panel.

The notation, method of detection, associated with each of these codes are as indicated; a 4-digit code provides details, and may be checked in service mode (COPIER>DISPLAY>ERR).

Code	Name or description	Code	Name or description
[Reader Unit-Related]		E505	backup RAM fault
E202	No. 1 mirror base HP detection fault	E512	delivery fault
E220	scanning lamp activation fault	E530	alignment fault
E302	shading correction related fault	E531	stapling fault
[Printer Unit-Related]		E532	stapling shift fault
E000	inadequate rise in temperature in fixing unit at power-on	E535	swing fault
E001	faulty rise in temperature of fixing unit	E540	tray ascent/descent fault
E002	inadequate rise in temperature of fixing unit	E584	No. 2 feed fault
E003	low temperature in fixing unit after standby	E5F0	saddle paper positioning fault
E004	protective circuit fault in fixing unit	E5F1	saddle paper folding fault
E012	drum ITB motor fault	E5F2	saddle guide fault
E020	drum/developer-related fault	E5F3	saddle alignment fault
E032	NE controller counter fault	E5F4	saddle rear stapling fault
E110	laser scanner motor operation fault	E5F5	saddle front stapling fault
E243	control panel fault	E5F6	saddle paper edging plate staple error
E248	reader controller PCB EEPROM fault	E5F8	saddle connector fault
E315	image data fault	E5F9	saddle switch fault
E351	ECO PCB fault	E711	IPC communication error
E602	hard disk fault	E712	DADF communication error
E604	image memory (SDRAM) fault	[Finisher-M1-Related]	
E605	image memory battery fault	E500	finisher communication fault
E606	hard disk fault	E512	delivery fault
E674	FAX board fault	E514	stack processing (clockwise) fault
E717	fault in communication with NE controller	E530	rear alignment fault
E719	coin vendor fault	E531	stapling fault
E732	reader communication error	E537	front alignment fault
E733	printer communication error	E577	stack processing (counterclockwise) fault
E740	Ethernet board fault	E580	stack tray ascent/descent fault
E744	language file fault	E711	IPC communication error
E745	TokenRing board fault	E713	finisher cassette pedestal communication error
E747	image processing ASIC or memory control/ communication ASIC fault	[Options Board-Related]	
E804	power supply cooling fan error	E731	UFR board fault
E804	controller fan fault	[DADF-K1-Related]	
E805	fixing heat exhaust fan fault	E402	feed motor fault
E805	cleaner fan error	E404	delivery motor fault
[Finisher-N1/Saddle-Finisher-N2-Related]		E711	IPC communication fault
E500	finisher communication fault	E712	DADF communication error
E503	saddle communication error	[Cassette Pedestal-Related]	
E504	stack size detection fault	E716	cassette pedestal/printer unit communication fault

2 Error Code Related to the Reader Unit

Code	Detail	Description	Timing of detection
E202	A fault has occurred in detecting the No. 1 mirror home position.		
0000		The No. 1 mirror base moves in reverse but does not move to its home position.	The home position sensor does not go ON within a specific period of time.
0001		The No. 1 mirror base moves forward but does not move from its home position.	The home position sensor does not go OFF within a specific period of time.
E220	A fault has occurred in activating the scanning lamp.		
0000		The intensity of the scanning lamp has dropped.	During shading adjustment at time of power-on, the intensity detected by the CCD is below a specific level.
E302	A fault has occurred in relation to shading correction.		
0000		A time-out has occurred in shading operation.	The shading processing does not end 1 sec after it has started.
0001		A time-out has occurred in gain/offset correction by the analog processor.	The gain/offset correction (setting operator) by the analog processor does not end 1 sec after it has started.

3 Error Code Related to the Printer Unit

Code	Detail	Description	Timing of detection
E000		The rise in temperature in the fixing unit at time of power-on is inadequate.	
	0001		After power-on, the output of the non-contact thermistor does not reach 40°C within 180 sec.
E001		The fixing unit is overheating.	
	0001		The high-temperature detection port continues to remain ON for 500 msec.
	0003		The reading of the no-contact thermistor remains 250°C for 500 msec.
	0004		The difference in temperature between the non-contact thermistor and the end thermistor remains 80°C or more for 500 msec.
	0005		At the end of initial rotation, the difference in temperature between the sub (end) thermistor and the main (non-contact) thermistor is 20°C or more for 100 msec. (A reversal in temperature (caused, for example, by a piece of residual paper) is detected.)
E002		The rise in temperature of the fixing unit is inadequate.	
	0002		The output of the non-contact thermistor does not reach 60°C within 240 sec after it has reached 40°C.
	0003		The output of the non-contact thermistor does not reach 90°C within 180 sec after it has reached 60°C.
	0004		The output of the non-contact thermistor does not reach 120°C within 240 sec after it has reached 90°C.
	0005		The output of the non-contact thermistor does not reach 140°C within 180 sec after it has reached 120°C.
	0006		The output of the non-contact thermistor does not reach 160°C within 180 sec after it has reached 140°C.
	0007		The output of the non-contact thermistor does not reach 180°C within 180 sec after it has reached 160°C.

Code	Detail	Description	Timing of detection
	0008		The output of the non-contact thermistor does not reach 190°C within 180 sec after it has reached 180°C.
	0101		The output of the non-contact thermistor does not reach 120°C within 300 sec after power-on.
	0102		The output of the non-contact thermistor does not reach 190°C within 300 sec after it has reached 120°C.
E003	The temperature of the fixing unit is abnormally low after standby.		
	0001		After standby, the reading of the non-contact thermistor remains 120°C or less for 10 sec.
E004	The protection circuit of the fixing unit is faulty.		
	0001		A short circuit of the triac is detected for 500 msec continuously.
	0002		An open circuit of the temperature detection thermistor inside the non-contact thermistor is detected for 500 msec continuously.
	0003		A short circuit of the temperature detecting thermistor inside the non-contact thermistor is detected for 500 msec continuously.
	0004		An open circuit of the infrared detecting thermistor inside the non-contact thermistor is detected for 500 msec continuously.
	0005		A short circuit of the infrared detecting thermistor inside the non-contact thermistor is detected for 500 msec continuously.
E012	The drum ITB motor is faulty.		
	0001	The ITB drum motor fails to rotate.	The lock (normal state) signal is not detected within 2 sec after the ITB drum motor control signal has gone ON or the motor speed has been changed.
	0002	The ITB drum motor fails to rotate after it has rotated.	The lock (normal state) signal stops 0.5 sec later.
	0003		The lock (normal state) signal remains even when the ITB drum motor has been stopped (i.e., the lock (normal state) signal is detected continuously for 2 sec after the ITB drum motor control signal has been turned OFF).

Code	Detail	Description	Timing of detection
E020	There is a fault associated with the drum/developer.		
		For the first 2 digits of detail code xx12 through xxD0, xx=01: Y xx=02: M xx=03: C xx=04: Bk	
	xx20	There is a fault/open circuit in the ATR sensor. The drum unit is not fitted normally, or is faulty.	The fault can occur as when a new drum unit has been fitted. It is detected in about 90 to 120 sec after idle rotation of the developing assembly.
	xx24	There is a fault/open circuit in the SALT sensor.	The fault can occur as when a new drum unit has been fitted. It is detected during ATR control or in about 150 sec after idle rotation of the developing assembly.
	xx25	There is a fault/open circuit in the SALT sensor. The ITB has deteriorated.	The fault can occur as when a new drum unit has been fitted. It is detected during ATR control or in about 150 sec after idle rotation of the developing assembly.
	xx30	There is a fault/open circuit in the ATR sensor. The setting of the ATR sensor computation value is wrong. The drum unit is not fitted properly, or is faulty.	The fault can occur as when a new drum unit has been fitted. It is detected in about 90 to 120 sec after idle rotation of the developing assembly.
	xx34	The sample image fails to be drawn in ATR control. There is a fault/open circuit in the SALT sensor. The drum unit is faulty. The ITB has deteriorated.	The fault can occur as when a new drum unit has been fitted. It is detected during ATR control or in about 150 sec after idle rotation of the developing assembly.
	xx35	There is a fault/open circuit in the SALT sensor.	The fault can occur as when a new drum unit has been fitted. It is detected during ATR control or in about 150 sec after idle rotation of the developing assembly.
	xx40	The ATR sensor communication value is faulty. There is a fault/open circuit in the ATR sensor. The drum unit has been fitted improperly. (The machine cannot detect the drum unit). The drum unit is faulty.	The fault can occur as when a new drum unit has been fitted. It is detected in about 90 to 120 sec after idle rotation of the developing assembly.
	xx50	The developer concentration computation value is faulty (set when a new drum unit is fitted).	The fault occurs when an image is being formed. It is detected when toner supply operation is started.

Code	Detail	Description	Timing of detection
xx60		The developer concentration target value is faulty (set when a new drum is fitted; the value is extremely small).	The fault occurs when an image is being formed. It is detected when toner supply operation is started.
xx70		The developer concentration target value is faulty (set when a new drum unit is fitted; the value is extremely small).	The fault occurs when an image is being formed. It is detected when toner supply operation is started.
xx80		The actual value is considerably high in relation to the ITB surface reflectance when a new drum unit is fitted. The SALT sensor is faulty.	The fault occurs while ATR control is being executed.
xx81		The actual value is considerably high in relation to the ITB surface reflectance when a new drum is fitted.	The fault occurs while ATR control is being executed.
xxA0		The measured value of the developer concentration is considerably low. The ATR sensor is faulty. The SALT sensor is faulty. The ITB is soiled.	The fault occurs when an image is being formed. It is detected when toner supply operation is started.
xxB0		The drum unit is approaching the end of its life and is causing the T/D ratio to drop. The ATR sensor has an open circuit.	The fault occurs when an image is being formed. It is detected when toner supply operation is started.
xxC0		The supply of toner for the toner container to the developing assembly is faulty. The developing assembly is supplied with toner excessively. The ATR sensor has an open circuit.	The fault occurs when an image is being formed.
xxD0		The supply of toner for the toner container to the developing assembly has failed. The toner cartridge motor fails to rotate. The toner container is empty. The toner supply mouth of the drum unit is damaged. The ATR sensor has an open circuit. For the first 2 digits of detail code xxEE, xx=00: fault in access to drum unit xx=01: fault in access to toner container	The fault occurs when an image is being formed and, in addition, when the T/D ratio drops while 20 prints are being made continuously. It is detected when toner supply operation is started.

Code	Detail	Description	Timing of detection
E032	The counter of the NE controller fails to operate.		
	0000		The counter function of the NE controller fails to operate.
E110	The operation of the laser scanner motor is faulty.		
	0110	The rotation of the Y laser scanner motor is faulty.	The motor lock signal remains in an unlock state for 1 sec or more while the laser scanner motor is in operation.
	0210	The rotation of the M laser scanner motor is faulty.	The motor lock signal remains in an unlock state for 1 sec or more while the laser scanner motor is in operation.
	0310	The rotation of the C laser scanner motor is faulty.	The motor lock signal remains in an unlock state for 1 sec or more while the laser scanner motor is in operation.
	0410	The rotation of the K laser scanner motor is faulty.	The motor lock signal remains in an unlock state for 1 sec or more while the laser scanner motor is in operation.
E240	The communication between the main motor controller and the DC controller is faulty.		
	0000		There is a fault in the serial communication between the main controller and the DC controller.
E243	The control panel is faulty.		
	0000		There is a fault in the communication between the controller and the control panel.
E248	The EEPROM on the reader controller PCB is faulty.		
	0000		The ID stored in EEPROM (read when the main power is turned on) and the ID stored in the flash ROM fail to match.
E315	The image data is faulty.		
	0001		A time-out condition has occurred in encoding/decoding processing of image data.
E351	The ECO-ID PCB is faulty.		
	0000		There is a fault in the initial communication.
E602	The hard disk is faulty.		
	0001		The fault may be a HD detection error, in which the HD cannot be detected. The machine may fail to become ready (returning an error code).
	0002		The startup file is absent. The program for the main CPU does not exist on the HD, in BOOTDEV/BOOT or the like.

Code	Detail	Description	Timing of detection
	0003		The fault is a HD write/abort error. The machine fails to read sectors of the HD.
	0005		It is a fault in the detection of the HD controller IC. It is detected when the HD controller IC cannot be recognized or an error is detected in it.
	0006		The auxiliary startup file is absent. The correct SUB CPU program does not exist on the HD or in BOOTDEV/BOOT or the like.
	0007		The color profile file does not exist. The correct color profile file does not exist in BOOTDEV/PDL or the like.
	01XX		The partition DOSDEV is faulty. (For detail code, see below.)
	02XX		The partition PSTDEV is faulty. (For detail code, see below.)
	03XX		The partition DOSDEV2 is faulty. (For detail code, see below.)
	04XX		The partition FSTPDEV is faulty. (For detail code, see below.)
	05XX		The partition DOSDEV3 is faulty. (For detail code, see below.)
	06XX		The partition PDLDEV is faulty. (For detail code, see below.)
	07XX		The partition DOSDEV4 is faulty. (For detail code, see below.)
	08XX		The partition BOOTDEV is faulty. (For detail code, see below.)
	09XX		The partition DOSDEV5 is faulty. (For detail code, see below.)
	FFXX		A fault exists in a partition that cannot be identified. (For detail code, see below.)

Detail code of E602

Last 2 bytes of detail code (indicated by XX)

	Description
01	Device error: sector, write/abort, other HDD access (driver) error
02	File system (logic) error: error detection by check processing; mounting failure
03	Other error: HDD connector fault; HDD detection failure; secondary error as of DRAM fault

Code	Detail	Description	Timing of detection
	10		HD controller HD controller IC, driver No. error
	11		HD controller IC, driver not installed
	12		HD controller IC, system error
	13		HD controller IC, device error
	14		HD controller IC, parameter error
	21		packet R/W file operation, system error
	22		packet R/W file operation, parameter error
	23		packet R/W file operation, packet DMC error
	24		packet R/W file operation, packet DMAC time-out
	25		packet R/W file operation, HD controller IC error
E604	There is a shortage in image memory (SDRAM).		
	0000		The remaining space in image memory is inadequate for the intended write/read op- eration.
E605	The battery for image memory is faulty.		
			A specific drop in voltage has been de- tected.
E606	The hard disk is faulty.		
	0001		A HD mounting error is detected when the HD is booted from BOOT ROM.
	0002		A reading error is detected when the HD is booted from BOOTROM.
E674	The fax board is faulty.		
	0000		
E717	The communication with the NE controller is faulty.		
	0000		The communication with the NE control- ler is disrupted and is not resumed within 3 sec thereafter.
E719	The coin vendor is faulty.		
	0000		The coin vendor cannot be detected at startup.
E732	There is a reader communication error.		
	0000		The reader unit cannot be detected at startup.

Code	Detail	Description	Timing of detection
E733	There is a printer communication error.		The printer unit cannot be detected at startup. There is no response to an error command from the printer unit.
	0000		
	0001		
E740	The Ethernet board is faulty.		The MAC address is illegal.
	0002		
E744	The language file is faulty.		The version of the language file on the HDD and the bootable version differ. The size of the language file on the HDD is too big. The language specified in Config.txt on the HDD cannot be found. A switchover to a language on the HDD cannot be made. The installed boot ROM is of a different type.
	0001		
	0002		
	0003		
	0004		
	1000		
E745	The TokenRing board is faulty.		An attempt at initialization fails (PCI).
	0001		
	0002	The MAC address is faulty.	
	0003	The board information cannot be obtained.	
	0004	There is a connection fault.	
E747	The image processing ASIC or the memory control/communication ASIC is faulty.		IC1010 (for image processing ASIC) on the main controller PCB or IC1012 (memory control/communication control ASIC, CPU) has a fault (e.g., image data transfer error).

E804	The power supply cooling fan is faulty.		The DC controller tried to start it up, but the fan has been identified as being at rest for 5 sec continuously.
	0000		
	The controller fan is faulty.		The controller fan has been identified as being at rest.
	0004		
E805	The fixing heat discharge fan is faulty.		The DC controller tried to start it up, but the fan has been identified as being at rest for 5 sec continuously.
	0000		
E805	The cleaner fan is faulty.		The DC controller tried to start it, but the fan has been identified as being at rest for 5 sec continuously.
	0001		

4 Error Code Related to the Finisher-N1/Saddle Finisher-N2

4.1 Finisher Unit

Code	Detail	Description	Timing of detection
E500	There is a fault in finisher communication.		
		There is a fault in data communication.	The communication between the machine and the finisher remains disrupted for 5 sec or more.
E503	There is a fault in saddle communication.		
	0002	There is a fault in data communication.	The communication between the saddle stitcher controller PCB and the finisher controller PCB remains disrupted for 5 sec or more.
E504	There is a fault in stack size detection.		
	0001	The height sensor (PS1) is faulty.	The communication between the height sensor and the finisher controller PCB is prevented. Or, there is a fault in the communication data.
	0002	The height sensor (PS1) is faulty.	The communication between the height sensor and the finisher controller PCB is prevented for 0.1 sec or more.
	0003	The connector of the height sensor (PS1) is faulty.	This fault is detected at power-on.
	0004	The DIP switch for the height sensor (PS1) is not adjusted correctly.	There is a fault in the adjustment of the sensor by the DIP switch.
E505	There is a fault in the backup RAM.		
	0001	The checksum value of the finisher controller PCB is faulty.	This fault is detected at power-on.
E512	There is a fault in delivery.		
	0001	The delivery roller, feed motor (M2), or feed motor clock sensor (PI10) is faulty.	The delivery motor clock sensor fails to generate the target number of clock pulses within 10 sec at the start of operation.
	0002	The delivery roller, feeder motor (M2), or feeder motor clock sensor (PI10) is faulty.	There is no clock pulse for a feed equivalent for 0.2 during communication.

Code	Detail	Description	Timing of detection
E530	There is a fault in alignment.		
	0001	There is an excess load on the alignment motor (M3), aligning plate home position sensor (PI6), or aligning plate.	The aligning plate does not leave the aligning plate home position sensor when the alignment motor has been driven for 2 sec.
	0002	There is an excess load on the rear alignment motor (M3), rear aligning plate home position sensor (PI6), or rear aligning plate.	The aligning plate does not return to its home position when the aligning plate motor has been driven for 2 sec.
E531	There is a fault in stapling.		
	0001	The stapler motor (M6) or the stapling home position detecting switch (MS7) is faulty.	The stapler does not leave the stapler shift position when the stapler shift motor has been driven for 0.5 sec.
	0002	The stapler motor (M6) or the stapling home position detecting switch (MS7) is faulty.	The stapler does not return from the stapler shift position when the stapler shift motor has been driven for 0.5 sec.
E532	There is a fault in the shift of the stapler.		
	0001	The stapler shift motor (M4) or the stapler shift home position sensor (PI7) is faulty. There is a fault in the path of the stapler shift base.	The stapler shift base does not leave the stapler shift home position sensor when the stapler shift motor has been driven for 4 sec.
	0002	The stapler shift motor (M4) or the stapler shift home position sensor (PI7) is faulty. There is a fault in the path of the stapler shift base.	The stapler shift base does not return from the stapler shift home position sensor when the stapler shift motor has been driven for 4 sec.
E535	There is a fault in the swing mechanism.		
	0001	The swing motor (M7) or the swing guide open sensor (PI18) is faulty.	The swing guide closed switch does not go ON when the swing motor has been rotated in reverse for 1 sec.
	0002	The swing motor (M7) or the swing guide closed switch (MS6) is faulty.	The swing guide open switch does not go ON when the swing motor has been rotated in reverse for 1 sec.

Code	Detail	Description	Timing of detection
0003		The safety area switch (MS3) or the swing guide switch 2 (MS6) is faulty.	The swing guide closed switch is OFF when the tray 1/2 is in the OFF position of the safety area switch while the tray ascent/descent motor is in operation.
0004		The swing motor (M7) or the swing motor clock sensor (PI20) is faulty.	There is no clock pulse for 0.2 sec while swinging operation is under way.
E540	There is a fault in the ascent/descent of the tray.		
0001		The tray ascent/descent motor (M5), the tray ascent/descent motor clock sensor (PI9/PI19), or tray home position sensor (PIE) is faulty.	The ascent/descent operation does not end within 15 sec after the tray ascent/descent motor has been driven; or, the tray home position is not detected when it has been driven for 15 sec.
0002		The tray upper limit detecting switch (MS5) is faulty.	The tray upper limit detecting switch is ON during tray ascent/descent operation.
0003		The tray ascent/descent motor (M5) or the tray ascent /descent motor clock sensor 1/2 (PI9/PI19) is faulty.	There is no clock pulse for 0.2 sec or more from the clock sensor when the tray ascent/descent motor has been driven.
E584	There is a fault in feed operation (No. 2).		
0001		The No. 2 feed motor (M8) or the shutter open sensor (PI5) is faulty.	The shutter open sensor does not go ON when the No. 2 feed motor has been rotated in reverse for 1 sec or more.
0002		The No 2 feed motor (M8) or the shutter closed switch (MS4) is faulty.	The shutter closed switch does not go ON when the No. 2 feed motor has been rotated in reverse for 1 sec or more.
0003		The safety area detecting switch (MS3) or the shutter closed switch (MS4) is faulty.	The shutter closed switch is OFF when the tray 1/2 is in the OFF position of the safety area switch while the tray ascent/descent motor is in operation.

4.2 Saddle Unit

Code	Detail	Description	Timing of detection
E5F0	There is a fault in paper positioning for the saddle.		
0001		The paper positioning plate motor (M4S) or the paper positioning plate home position sensor (PI7S) is faulty.	The paper positioning plate home position sensor does not go ON when the paper positioning plate motor has been driven for 1.33 sec.
0002		The paper positioning plate motor (M4S) or the paper positioning plate home position sensor (PI7S) is faulty.	The paper positioning plate home position sensor does not go OFF when the paper position plate motor has been driven for 1 sec.
E5F1	There is a fault in paper folding for the saddle.		
0001		The paper fold motor (M2S) or the paper fold motor clock sensor (PI4S) is faulty.	The number of detection pluses of the paper fold motor clock sensor falls below a specific value.
0002		The paper fold motor (M2S) or the paper fold motor clock sensor (PI4S) is faulty.	The state of the paper fold home position sensor remains unchanged when the paper fold motor has been driven for 3 sec.
E5F2	There is a fault in the saddle guide.		
0001		The guide motor (M2S) or the guide home position sensor (PI13S) is faulty.	The guide home position sensor does not go ON when the guide motor has been rotated for 0.455 sec.
0002		The guide motor (M3S) or the guide home position sensor (PI13S) is faulty.	The guide home position sensor does not go OFF when the guide motor has been driven for 1 sec.
E5F3	There is a fault in saddle alignment.		
0001		The alignment motor (M5S) or the aligning plate home position sensor (PI5S) is faulty.	The aligning plate home position sensor does not go ON when the alignment motor has been driven for 0.5 sec. (initially, driven for 1.67 sec)
0002		The alignment motor (M5S) or the aligning plate home position sensor (PI5S) is faulty.	The alignment plate home position sensor does not go OFF when the alignment motor has been driven for 1 sec.
E5F4	There is a fault in stapling at the saddle rear.		
0001		The stapler motor (rear, M6S) or the stacking home position sensor (rear, MS5S) is faulty.	The stitching home position sensor does not go OFF when the stitch motor (rear) has been rotated clockwise for 0.5 sec.
0002		The stitch motor (rear, M67S) or the stitching home position sensor (rear, MS5S) is faulty.	The stitching home position sensor does not go ON when the stitch motor (rear) has been rotated in reverse for 0.5 sec or more.

Code	Detail	Description	Timing of detection
E5F5	There is a fault in stapling at the saddle front.		
0001		The stitch motor (front, M7S) or the stitching home position sensor (front, MS7S) is faulty.	The stitching home position sensor does not go OFF when the stitch motor (front) has been driven clockwise for 0.5 sec or more.
0002		The stitch motor (front, M7S) or the stitching home position sensor (front, MS7S) is faulty.	The stitching home position sensor does not go ON when the stitch motor (front) has been driven in reverse for 0.5 sec or more.
E5F6	There is a fault in stapling by the saddle paper pushing plate.		
0001		The paper pushing plate motor (M8S) or the paper pushing plate home position sensor (PI4S) is faulty.	The paper pushing plate home position sensor does not go ON when the paper pushing plate motor has been driven for 0.3 sec or more.
0002		The paper pushing plate motor (M8S) or the paper pushing plate home position sensor (PI14S) is faulty.	The paper pushing plate home position sensor does not go OFF when the paper pushing plate motor has been driven for 80 msec.
0003		The paper pushing plate motor (M8S) or the paper pushing plate leading edge position sensor (PI15S) is faulty.	The paper pushing plate leading edge position sensor does not go OFF when the paper pushing plate motor has been driven for 80 msec.
0004		The paper pushing plate motor (M8S) or the paper pushing plate motor clock sensor (PI1S) is faulty.	The number of detection pulses of the paper pushing plate motor clock sensor has dropped below a specific value.
0005		The paper pushing plate motor (M8S) or the paper pushing plate leading edge position sensor (PI15S) is faulty.	The paper pushing plate leading edge positioning sensor does not go ON when the paper pushing plate motor has been driven for 0.3 sec or more.
E5F8	There is a fault in the saddle connector.		
0001		The connector of the guide home position sensor (PI13S) is faulty.	The connector of the guide home position sensor has been identified to have been disconnected.
0002		The connector of the paper pushing plate home position sensor (PI14S) is faulty.	The connector of the paper pushing plate home position sensor is identified to have been disconnected.
0003		The connector of the paper pushing plate leading edge position sensor (PI15S) is faulty.	The connector of the paper pushing plate position sensor is identified to have been disconnected.

Code	Detail	Description	Timing of detection
E5F9	There is a fault in the saddle switch.		
	0001	The inlet cover switch (MS1S), front cover switch (MS2S), or delivery cover switch (MS3S) is faulty.	The inlet cover switch is identified to be open for 1 sec or more after the start of initial rotation or of printing in the host machine with any of the following sensor identifying the cover to be closed: <ul style="list-style-type: none"> • inlet cover sensor (PI9S) • front cover open/closed sensor (PI2S) • delivery cover sensor (PI3S)
	0002	The front cover switch (MS2S) or the delivery cover switch (MS3S) is faulty.	The front cover switch is identified to be open for 1 sec or more after the start of initial rotation or of printing in the host machine with any of the following sensors identifying the cover to be closed: <ul style="list-style-type: none"> • inlet cover sensor (PI9S) • front cover open/closed sensor (PI2S) • delivery cover sensor (PI3S)
	0003	The delivery cover switch (MS3S) is faulty.	The delivery cover switch is identified to be open for 1 sec or more after the start of initial rotation or of printing in the host machine with any of the following sensors identifying the cover to be closed: <ul style="list-style-type: none"> • inlet cover sensor (PI9S) • front cover open/closed sensor (PI2S) • delivery cover sensor (PI3S)
E711	There is a fault in IPC communication.		
	0001	There is a fault in data communication. The ADF controller or the reader controller PCB is faulty. The connector between the reader unit and the DADF has poor contact.	An error has been detected 4 times or more for 1.5 sec after the communication is disrupted between the reader unit and the DADF.
	0002	There is a fault in data communication. The finisher controller, pedestal controller, or DC controller PCB is faulty. The connector between the finisher and the machine has poor connection.	An error has been detected 4 times or more for 1.5 sec after the communication between the finisher and the machine is disrupted and, in addition, an attempt at recovery has failed.

Code	Detail	Description	Timing of detection
E713	There is a fault in the communication between the finisher and the cassette pedestal.	There is a fault in data communication. The cassette pedestal controller or the finisher controller PCB is faulty.	The communication between the finisher and the machine is disrupted.

5 Error Code Related to the Finisher-M1

Code	Detail	Description	Timing of detection
E500	There is a fault in finisher communication.	There is a fault in data communication.	The communication between the machine and the finisher is disrupted and, in addition, an attempt at recovery within 5 sec fails.
E512	There is a fault in delivery.	The delivery motor (M1) or the delivery clock sensor (S1) is faulty. The connector is disconnected.	The delivery clock sensor signal is not detected when the delivery motor has been driven for 70 mm.
E514	There is a fault in stack processing (clockwise direction).	The stack processing motor (M2) or the stack delivery lever home position sensor (S8) is faulty. The connector is disconnected. The stack delivery belt or the return roller is faulty.	The stack delivery lever fails to reach its home position when the stack processing motor has been driven for a specific period of time at start of operation.
E530	There is a fault in rear alignment.	The rear alignment motor (M4) or the rear aligning plate home position sensor (S7) is faulty. An excess load is imposed on the rear aligning plate.	The rear aligning plate fails to reach the home position sensor or fails to leave the aligning plate home position sensor when the rear aligning plate has been driven for a specific period of time.
E531	There is a fault in stapling.	The stapler motor (M6) or the stapling home position sensor (S17) is faulty. The stapler harness is faulty.	The stapler fails to leave the stapling home position sensor when the stapler shift motor has been driven for 0.5 sec, or does not return to the stapler home position sensor.
E537	There is a fault in front alignment.	The front alignment motor (M3) or the front aligning plate home position sensor (S6) is faulty. An excess load is imposed on the front aligning plate.	The aligning plate fails to reach the aligning plate home position sensor when the rear alignment motor has been driven for a specific period of time, or fails to leave the aligning plate home position sensor.

Code	Detail	Description	Timing of detection
E577	There is a fault in stack processing (counterclockwise direction).		
		The stack processing motor (M2) or the return controller home position sensor (S3) is faulty. The connector is disconnected. The stack delivery lever or the return roller is faulty.	The return roller fails to reach the return roller home position sensor when the stack processing motor has been driven for a required period of time.
E580	There is a fault in ascent/descent of the stack tray.		
		The stack tray ascent/descent motor (M5), stack tray paper height sensor (S10), or the stack tray ascent/descent motor clock sensor (S9) is faulty. The connector is disconnected. An excess load is imposed on the stack tray ascent/descent motor.	The stack tray upper limit sensor goes ON while the stack tray ascent/descent motor is in operation, or the clock pulse of the stack tray direction motor clock sensor is not detected 15 times or more within 0.8 sec. The stack tray does not reach the stack tray height sensor within 4 sec after the stack tray ascent/descent motor has started ascent operation.
E711	There is a fault in IPC communication.		
	0001	There is a fault in data communication. The ADF controller or the reader controller PCB is faulty. The connector between the reader unit and the DADF has poor connection.	An error has been detected 4 times or more within 1.5 sec after the communication between the reader unit and the DADF has been disrupted.
	0002	There is a fault in data communication. The finisher controller, pedestal controller, or DC controller PCB is faulty. The connector between the finisher and the machine has poor contact.	An error has been detected 4 times or more within 1.5 sec after the communication between the finisher and the machine has been disrupted and, in addition, an attempt at recovery has failed.
E713	There is a fault in the communication between the finisher and the cassette pedestal.		
		There is a fault in data communication. The cassette pedestal controller or the finisher controller PCB is faulty.	The communication between the finisher and the machine is disrupted.

6 Error Code Related to the Options Board

Code	Detail	Description	Timing of detection
E731	There is a fault in the UFR board.		
	3000	The UFR board cannot be recognized.	
	3001	The UFR board cannot be initialized.	
	3002	The RAM bus cannot be initialized.	
	3015	No image data arrives at the main controller PCB.	

7 Error Code Related to the DADF-K1

Code	Detail	Description	Timing of detection
E402	There is a fault in the feeder motor.	The feeder motor (M2) fails to rotate. The feeder motor clock sensor (SR1) is faulty.	The feeder motor encoder pulse is not detected within 0.3 sec after the DF feeder motor drive signal has been turned ON.
E404	There is a fault in the delivery motor.	The face-down delivery motor (M3) fails to rotate. The face-down delivery motor clock sensor (SR7) is faulty.	The face-down delivery motor encoder pulse is not detected within 0.3 sec after the face-down delivery motor drive signal has been turned ON.
E711	There is a fault in IPC communication.		
	0001	There is a fault in data communication. The ADF controller or the reader controller PCB is faulty. The connector between the reader unit and the ADF has poor connection.	An error has been detected 4 times or more within 1.5 sec after the communication between the reader unit and the ADF has been disrupted.
	0002	There is a fault in data communication. The finisher controller, pedestal controller, or DC controller PCB is faulty. The connector between the finisher and the cassette pedestal has poor contact.	An error has been detected 4 times or more within 1.5 sec after the communication between the finisher and the machine has been disrupted and, in addition, an attempt at recovery has failed.
E712	There is a fault in the communication between the ADF and the reader unit.	There is a fault in data communication. The ADF controller or the reader controller PCB is faulty. The connector between the reader unit and the ADF has poor contact.	An attempt at recovery fails 5 sec or more after the communication between the reader unit and the ADF has been disrupted.

8 Error Code Related to the Cassette Pedestal

Code	Detail	Description	Timing of detection
E716	There is a fault in the communication between the cassette pedestal and the printer unit.	There is a fault in data communication. The DC controller or the cassette pedestal controller PCB is faulty.	An attempt at recovery fails for 2 sec or more after the communication between the cassette pedestal and the machine has failed.

CHAPTER 5

SERVICE MODE

1 Overview

1.1 Service mode screen configuration

As shown below, the service modes use three screen levels: initial screen → main/intermediate item screen → sub-item screen.

One set of modes are used for normal maintenance (Level 1 modes), and another set are used for troubleshooting (Level 2 modes).

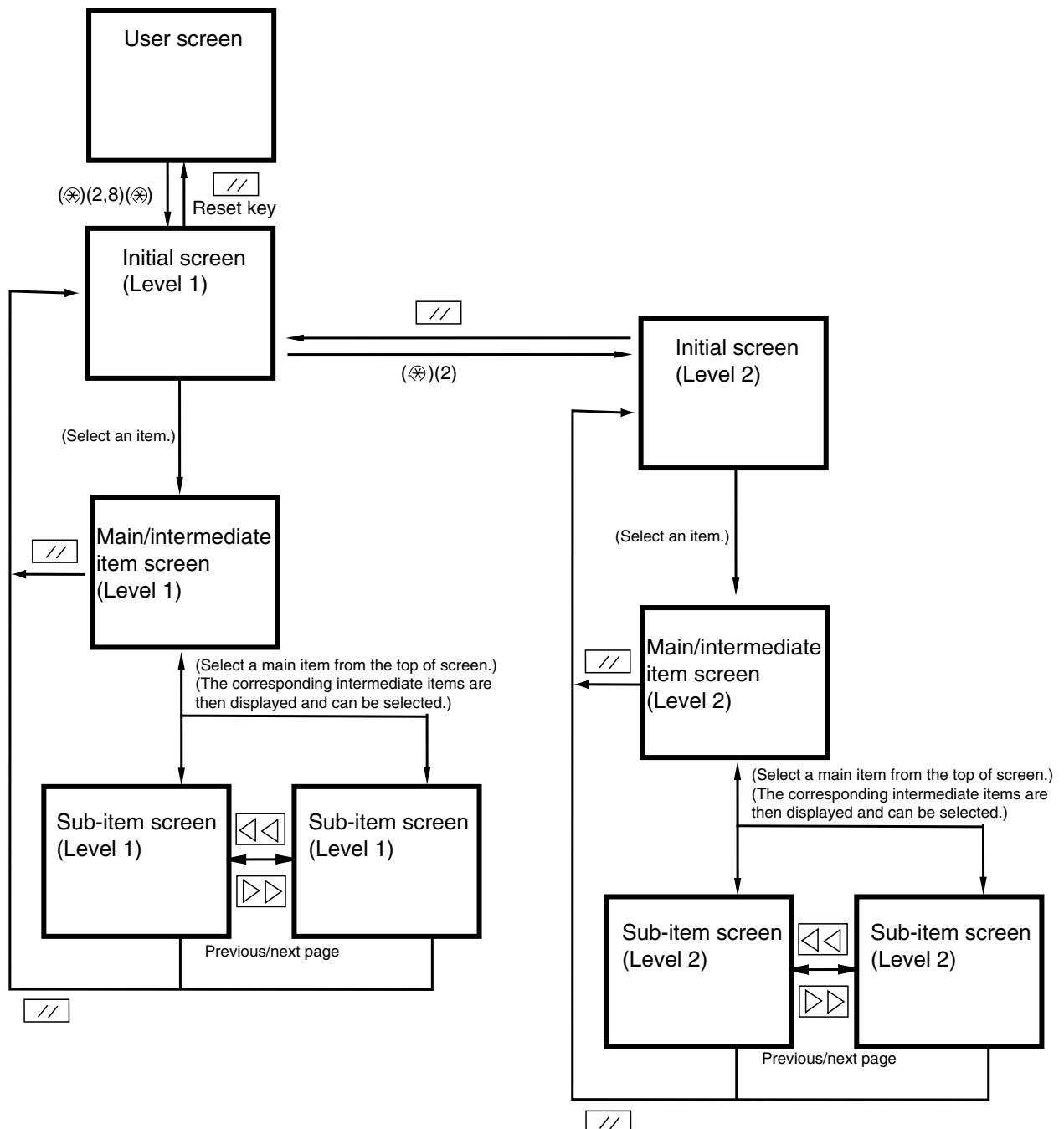

F05-101-01

The copier has the 7 service modes listed below.

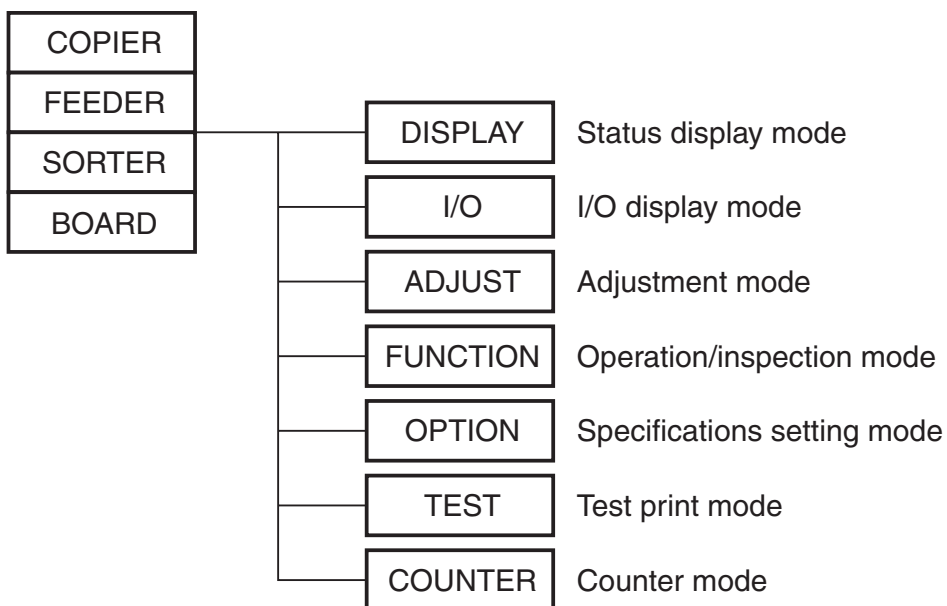

F05-101-02

1.2 Entering or selecting service modes



To execute a copier operation using a service mode, remove the cable from the external controller or the cable from the network before entering the desired mode. Take care when using the FUNCTION (operation/inspection mode) mode, as the copier may malfunction and be damaged if a print job is received from outside while an operation is executing with this mode in effect.

- 1) Press the asterisk key (\star) on the operation panel.
- 2) Press 2 and 8 simultaneously on the numeric keypad.
- 3) Press the asterisk key (\star) on the operation panel.

The initial screen (see below) now appears.

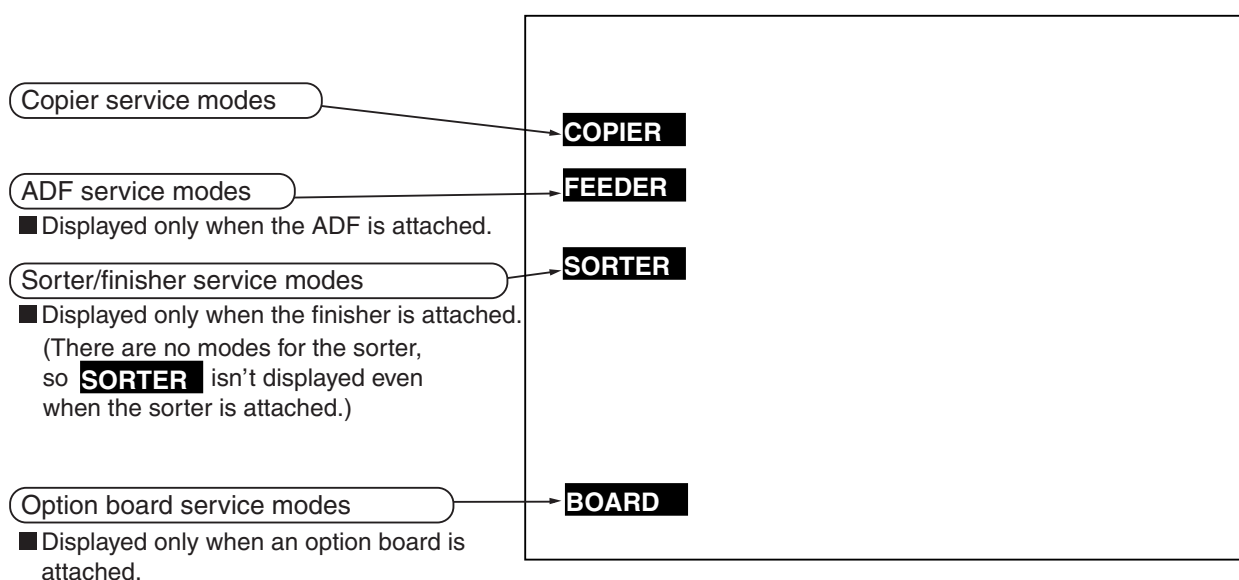

F05-102-01

1.3 Exiting service modes

When the reset key is pressed once, the display returns to the service mode initial screen (F00-102-01). When the reset key is pressed twice, the service modes are exited, and the display returns to the user screen (standard screen).



When using the ADJUST, FUNCTION or OPTION service mode, be sure to turn the main power switch ON/OFF after exiting the mode.

1.4 Service mode backup

Each copier is adjusted at time of factory shipment, and the adjusted values are written on the service labels.

If you replace the reader controller PCB or DC controller PCB, or clear the RAM, the adjusted ADJUST and OPTION values are restored to their default values. Therefore, always enter the new service mode values on the service labels when you change the values as a result of adjusting the copier in the market. If the item you need to enter is not listed on the service label, enter it in a blank box.

- Reader controller PCB service label:
Back side of reader unit's left cover [1]

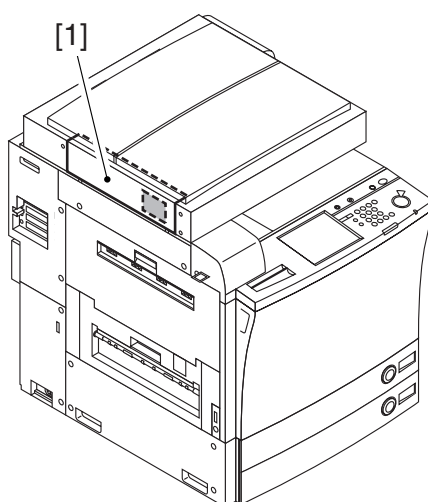

F05-104-01

- Main controller PCB/DC controller PCB service label:
Back side of service book case [1] on inside of printer unit front cover (see figure below)

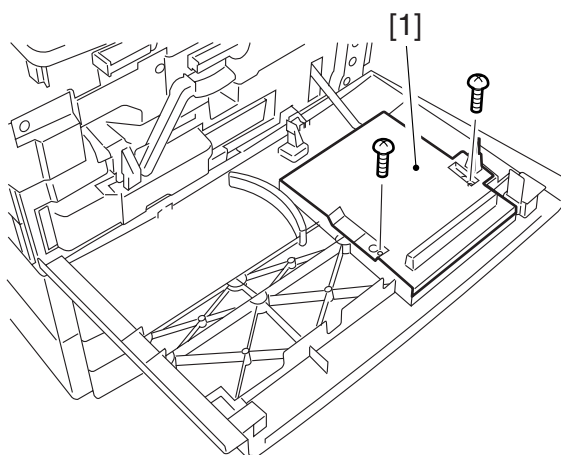

F05-104-02

1.5 Basic operation

1.5.1 Initial screen

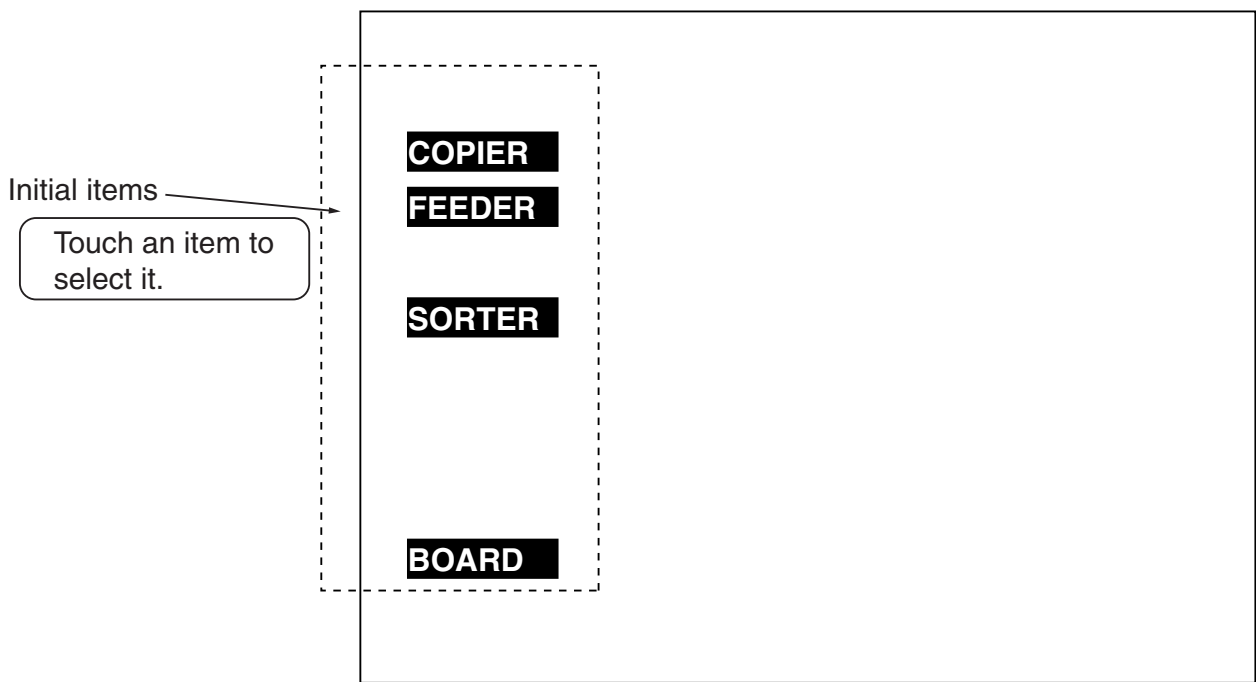

F05-105-01

1.5.2 Main/intermediate item screen

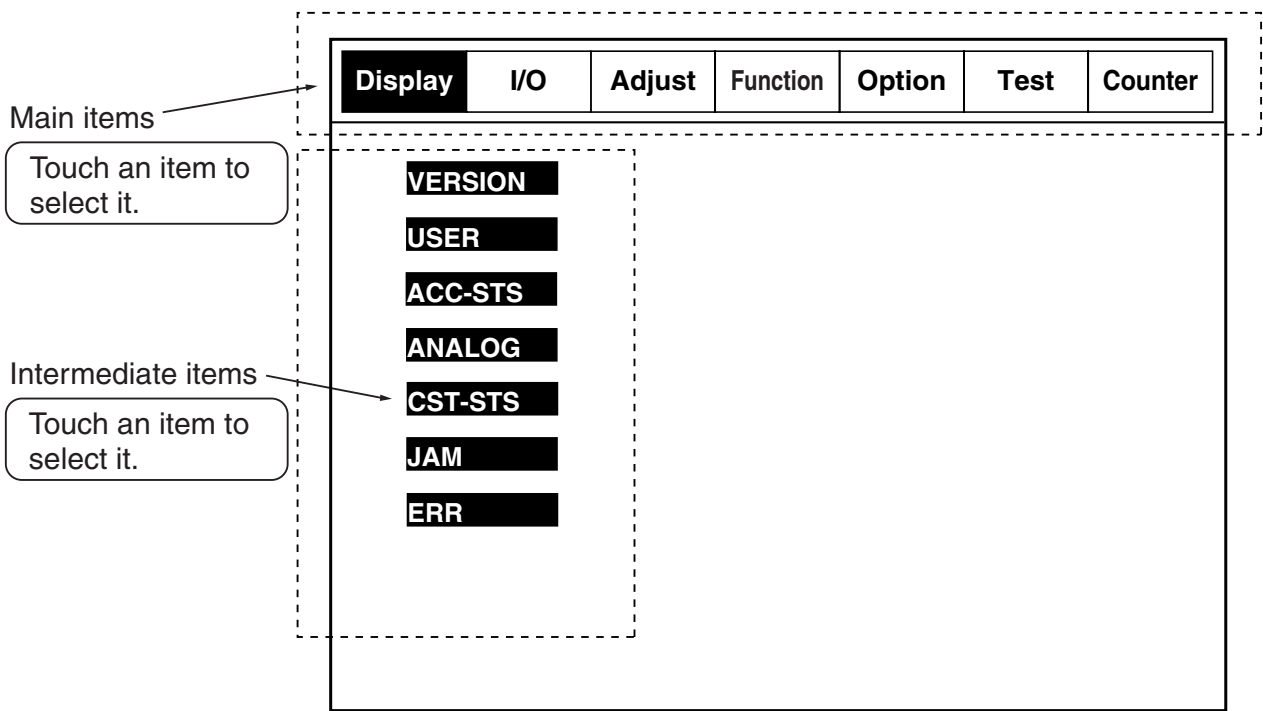

F05-105-02

1.5.3 Sub-item screen

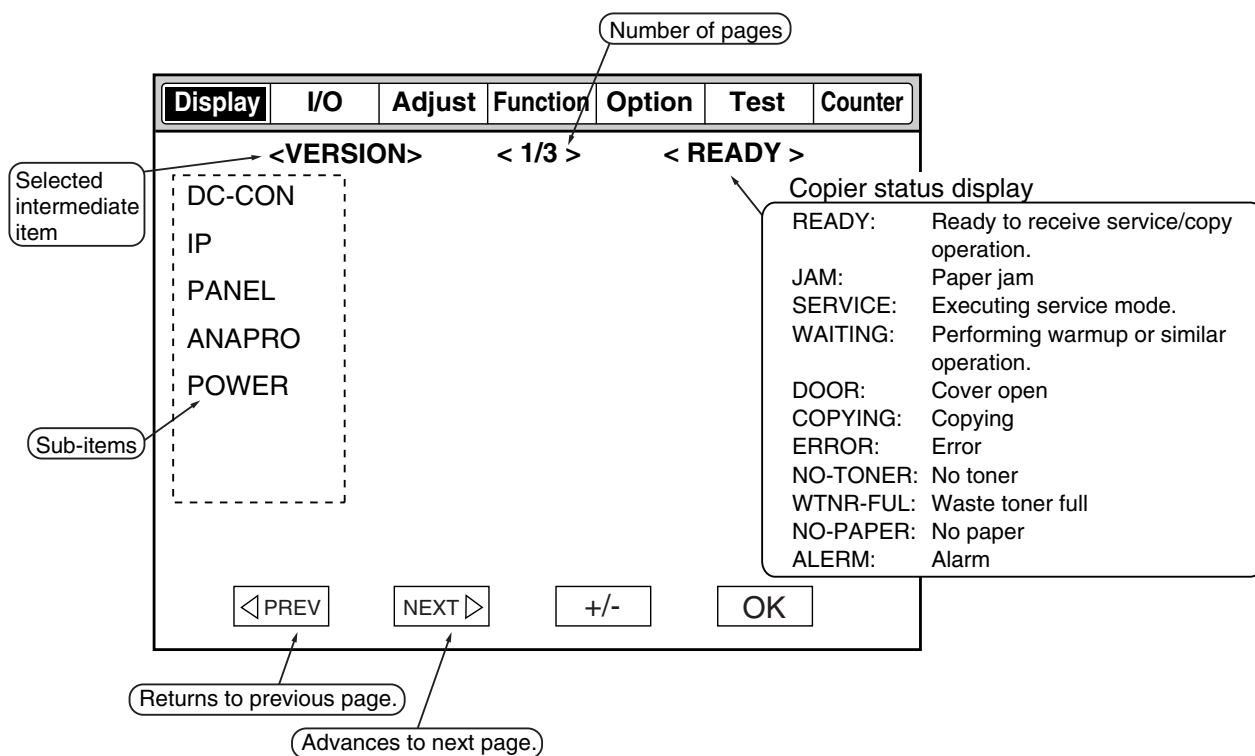

F05-105-03

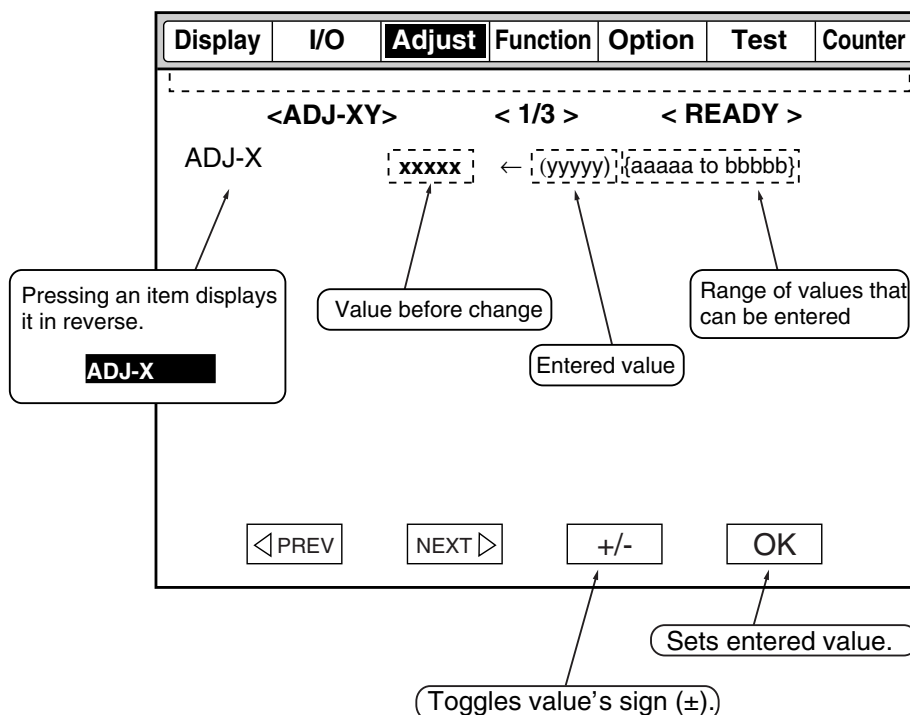

- Stop** key: Stops running operations.
- Clear** key: Clears value.
- Start** key: Starts copying without exiting service mode.

F05-105-04

COPIER>DISPLAY

2 DISPLAY (status display mode): Level 1

2.1 COPIER

The COPIER>DISPLAY (Level 1) screen is shown below.

Display	I/O	Adjust	Function	Option	Test	Counter
VERSION						
USER						
ACC-STS		DENS				
ANALOG						
JAM		MISC				
ERR		ALARM-2				

F05-201-01

<VERSION>

Displays the ROM version of each PCB (for the copier and options).

- Example display: <R-CON XX.YY> XX: Version number,
YY: Development management number
- If no PCB is connected, <--.--> is displayed.

DC-CON

ROM version of DC controller PCB.

R-CON

ROM version of reader controller PCB.

PANEL

ROM version of control panel CPU PCB.

ECO

ROM version of ECO PCB.

FEEDER

ROM version of DADF controller PCB.

SORTER

ROM version of finisher controller PCB.

FAX

ROM version of fax board.

NIB

Network software version.

PS/PCL

UFR board (PS/PCL function) version.

LIPS

UFR board (LIPS function) version.

SDL-STCH

ROM version of saddle stitcher controller PCB.

OP-CON

ROM version of cassette pedestal controller PCB.

MN-CON

System software version of main controller PCB.

COPIER>DISPLAY

BOOT-ROM

BOOT ROM version of main controller PCB.

- Copy model/GDI-UFR model: xx.yy C
 - LIPS model: xx.yy L
 - PL/PCL model: xx.yy N
-

DIAG-DVC

ROM version of card reader D1/NE controller A1.

RUI

Remote UI version.

LANG-EN

English language file version.

LANG-FR

French language file version.

LANG-DE

German language file version.

LANG-IT

Italian language file version.

LANG-JP

Japanese language file version.

GDI-UFR

UFR board (GDI-UFR function) version.

<ACC-ST>

Displays whether options are connected.

FEEDER

Displays whether DADF is connected.

0: Not connected, 1: Connected

SORTER

Displays whether finisher is connected.

0: Not connected, 1: Finisher M1 or N1 connected,

2: Saddle finisher N2 connected

DECK

Displays whether paper deck is connected.

0: Not connected, 1: Connected

CARD

Displays whether card reader is connected.

0: Not connected, 1: Connected

DATA-CON

Displays whether NE controller/A1 is connected.

0: Not connected, 1: Connected

RAM

Displays memory capacity of memory mounted on main controller PCB.

512 MB, 768 MB

COINROBO

Displays whether coin vendor is connected.

0: Not connected, 1: Connected

NIB

Displays whether network board is connected.

0: Not connected, 1: Ethernet board connected,

2: Token ring board connected,

3: Ethernet board and token ring board connected

NETWARE

Displays whether NetWare firmware is installed.

0: Not installed, 1: Installed

COPIER>DISPLAY

SEND

Indicates whether SEND function is appended.
0: No SEND function, 1: SEND function

<ANALOG>

Displays measured values of analog sensors.

TEMP

Copier's internal temperature (environment sensor) in °C

HUM

Copier's internal humidity (environment sensor) in %RH

ABS-HUM

Amount of moisture (environment sensor) in grams

FIX-C

Fixing roller's surface temperature (main thermistor's detected temperature)
in °C

FIX-E

Fixing roller's surface temperature (sub-thermistor's detected temperature)
in °C

<JAM>

Displays jam data.

Display	I/O	Adjust	Function	Option	Test	Counter
< JAM >		< 1/7 >		< READY >		
AA	BBBB	CCCC	DDDD	E	FFff	G HHHHHH IIIII
AA	BBBB	CCCC	DDDD	E	FFff	G HHHHHH IIIII
AA	BBBB	CCCC	DDDD	E	FFff	G HHHHHH IIIII
AA	BBBB	CCCC	DDDD	E	FFff	G HHHHHH IIIII
AA	BBBB	CCCC	DDDD	E	FFff	G HHHHHH IIIII
AA	BBBB	CCCC	DDDD	E	FFff	G HHHHHH IIIII
AA	BBBB	CCCC	DDDD	E	FFff	G HHHHHH IIIII
AA	BBBB	CCCC	DDDD	E	FFff	G HHHHHH IIIII
<div style="display: flex; justify-content: center; gap: 20px;"> ← → </div>						

F05-201-02

AA

Jam sequence number
1 to 50 (the larger the number, the older the jam)

BBBB

Date of jam

CCCC

Time of jam

DDDD

Time jam was restored

E

Jam location
0: Copier
1: DADF
2: Finisher

COPIER>DISPLAY

FFff

Jam code
FF: Jam type (see T05-201-01)
ff: Jam sensor (see T05-201-02 to 05)

G

Paper feed position
(See T05-201-06)

HHHHHH

Paper feed level software counter value

IIII

Paper size

FF: Jam type

Code	Jam type
00xx	Unused
01xx	Delay jam
02xx	Pileup jam
0Axx	Jam at power ON/jam during warmup
0Bxx	Front cover OPEN jam
0Dxx	Transparency-related jam

T05-201-01

ff: Jam sensor (printer unit)

Code	Sensor type
xx01	Cassette 1 retry paper sensor (PS16)
xx02	Cassette 2 retry paper sensor (PS17)
xx03	Cassette 3 retry paper sensor (PS53)
xx04	Cassette 4 retry paper sensor (PS57)
xx05	Registration sensor (PS26)
xx06	Fixing inlet sensor (PS27)
xx07	Fixing paper delivery sensor (PS25)
xx08	Face-down paper delivery sensor 1 (PS12)
xx09	Face-down paper delivery sensor 2 (PS6)
xx0A	Two-sided registration sensor (PS21)
xx0B	Two-sided paper feed sensor (PS24)
xx0C	Deck paper feed sensor (PS6D)
xx0D	Deck conveyor sensor (PS1D)
0D90	Transparency sensor (front OHP1, inner OHP2)
0D91	Manual feed paper sensor (PS10)
0D92	Transparency sensor (front OHP1, inner OHP2)
0D93	Transparency sensor (front OHP1, inner OHP2)

T05-201-02

COPIER>DISPLAY

ff: Jam sensor (finisher)

Code	Finisher M1 sensor/type	Finisher N1/saddle finisher N2 sensor/type
1103	Copier paper delivery delay jam	–
1104	Paper delivery pileup jam	–
1105	–	Jam due to early arrival while switching trays
1500	Staple jam in stapler	Staple jam in stapler
1300	Jam at power ON	Jam at power ON
1400	–	Front top cover OPEN jam
1011	–	Inlet path sensor delay jam
1013	–	Buffer path sensor delay jam
1014	–	Paper delivery path sensor delay jam
1121	–	Inlet path sensor pileup jam
1123	–	Buffer path sensor pileup jam
1124	–	Paper delivery path sensor pileup jam
1125	–	Staple tray sensor pileup jam
1181	Jam when pressing bundle	–
1182	Jam when returning bundle	–
1186	–	Staple jam in saddle stapler
1187	–	Saddle power ON jam
1188	–	Front lower cover OPEN jam
1191	–	Saddle conveying path sensor delay jam
1192	–	Saddle fold path sensor delay jam
11A1	–	Saddle conveying path sensor pileup jam
11A2	–	Saddle fold path sensor pileup jam

T05-201-03

ff: Jam sensor (DADF)

Jam name	Code	Sensor	Condition
Separation delay	0002	SR3	Separation sensor (SR3) didn't turn ON within 500 msec after separation motor (M1) switched to drive (forward).
Paper feed delay	0003	U502	Registration front sensor (U502) didn't turn ON within 1 sec from separation sensor (SR3) (for small size) or near separation sensor (for large size).
Paper feed pileup	0005	U502	Registration front sensor (U502) didn't turn OFF after conveyor motor turned ON and operated for 500 msec, after formation of resist loop.
Separation early delivery	0006	SR3	Separation sensor (SR3) was ON during start of document separation.
Reverse outlet delay	0011	U505	Reverse outlet sensor (U505) didn't turn ON at specified amount of time after trailing edge of document passed right edge of belt's presser roller.
Reverse outlet pileup	0012	U505	Reverse outlet sensor (U505) didn't turn OFF when paper was conveyed by paper delivery motor for 500 msec after trailing edge of document was detected by reverse paper delivery resist sensor (SR5).
Two-sided	0023	U505	Conveyor motor operated at constant speed with reverse outlet sensor (U505) still ON after a two-sided copy finished reversing.
Paper delivery inlet delay	0041	SR4	Reverse paper delivery inlet sensor (SR4) didn't turn ON when conveyor motor (M2) conveyed paper for 100 mm from start of document paper feed (for small size document) or from 51 mm in front of reverse paper delivery inlet sensor (SR4) (for large size/two-sided document).
Paper delivery inlet pileup	0042	SR4	Reverse inlet sensor (SR5) didn't turn OFF in specified amount of time after document's leading edge arrived at reverse registration roller nip (for small size), or after document's leading edge arrived at reverse outlet sensor (U505) (for large size/two-sided document).
Reverse registration delay	0043	SR5	Reverse paper delivery registration sensor (SR5) didn't turn ON at specified amount of time after reverse inlet sensor (SR4) turned ON.
Reverse registration pileup	0044	SR5	Reverse registration sensor (SR5) didn't turn OFF at specified amount of time after reverse paper delivery inlet sensor (SR4) turned OFF.
Reverse flapper failure	0045	U505	Flapper didn't switch when flapper switching for each paper delivery was checked by reverse outlet sensor (U505).
Paper delivery sensor delay (small size)	0046	SR5	Paper delivery sensor (SR5) didn't turn OFF after specified amount of time had elapsed from start of reverse operation of reverse paper delivery motor (M3).

T05-201-04

COPIER>DISPLAY

Jam name	Code	Sensor	Condition
Paper delivery sensor pileup (small size)	0047	SR5	Paper delivery sensor (SR5) didn't turn OFF after paper was conveyed 50 mm after document trailing edge passed paper delivery sensor (SR5).
Paper delivery sensor delay (large size/two-sided document)	0048	SR4	Reverse inlet sensor (SR5) didn't turn ON after specified amount of time elapsed after start of paper delivery.
Reverse paper delivery unit cover OPEN	0080	SR8	Reverse paper delivery unit cover was opened when copier was stopped due to lack of paper.
DADF OPEN	0081	SR6	DADF was opened when copier was stopped due to lack of paper.
Paper feed cover OPEN	0082	SR2	Paper feed unit cover was opened when copier was stopped due to lack of paper.
Document not removed	0088	SR4, SR5	Attempt to start paper feed was made with document left on document stand glass. Detected by reverse paper delivery inlet sensor (SR4) and reverse paper delivery registration sensor (SR5).
Timing failure 1	008A		Paper feed timing for second side of paper failed during two-sided copy operation. Alternately, end of task wasn't detected by inter-task monitoring after specified amount of time.
Timing failure 2	008B		During document conveying mode, when paper delivery clock sensor (SR7) was counting conveyed volume of document to deliver, paper feed of next document completed, and reverse paper delivery motor (M3) encoder pulse could no longer be detected.
Timing failure 3	008C		When the document is sent as a mixed load even though document mixed loading hasn't been set, the document size error alarm (0014) is generated, but since the jam must be processed, this jam display appears. 008C (jam) and 0014 (alarm) are displayed together, and the jam is restored automatically 5 seconds after being processed.
User DADF OPEN	0091	SR6	DADF was opened during DADF operation.
User cover OPEN	0092	SR2, SR8	Cover was opened during DADF operation.
Separation sensor initial status	0094	SR3	Separation sensor (SR3) was ON before separation of first document sheet.
Registration front sensor initial status	0095	U502	Registration front sensor (U502) was ON before separation of first document sheet.
Reverse paper delivery inlet sensor initial status	0096	SR4	Reverse paper delivery inlet sensor (SR4) was ON before separation of first document sheet.
Reverse paper delivery registration sensor	0097	SR5	Reverse paper delivery registration sensor (SR5) was ON before separation of first document sheet.

T05-201-05

G: Paper feed position

Code	Description
1	Cassette 1
2	Cassette 2
3	Cassette 3
4	Cassette 4
5	Side paper deck
6	Manual feed tray
7	Two-sided unit

T05-201-06

COPIER>DISPLAY

<ERR>

Displays error data.

Display	I/O	Adjust	Function	Option	Test	Counter
	< ERR >	< 1/7 >	< READY >			
AA	BBBB	CCCC	DDDD	EEEE	FFff	G
AA	BBBB	CCCC	DDDD	EEEE	FFff	G
AA	BBBB	CCCC	DDDD	EEEE	FFff	G
AA	BBBB	CCCC	DDDD	EEEE	FFff	G
AA	BBBB	CCCC	DDDD	EEEE	FFff	G
AA	BBBB	CCCC	DDDD	EEEE	FFff	G
AA	BBBB	CCCC	DDDD	EEEE	FFff	G
AA	BBBB	CCCC	DDDD	EEEE	FFff	G

F05-201-03

AA

Error sequence number
1 to 50 (the larger the number, the older the error)

BBBB

Date of error

CCCC

Time of error

DDDD

Time error was restored

EEEE

Error code

FFff

Detail code
'0000' if none.

G

Error location
0: Main controller
1: DADF
2: Finisher
3: Unused
4: Reader unit
5: Printer unit
6: PDL boards
7: Fax board

COPIER>DISPLAY

<DENS>

Displays concentration of developer in developer unit.

DENS-Y/M/C/K

Calculated value of developer concentration (indicated as % off target value)

Appropriate values -2.0 to 2.0%

Note Value is updated when toner is supplied after main power switch ON.

WINDOW-Y, M, C, K

SALT sensor window dirt coefficient (Y/M/C/Bk). The smaller the value, the dirtier the sensor window.

Appropriate values 50 or higher

Note Value is updated when ATR control operation is performed after main power switch ON.

SGNL-Y, M, C, K

Measured value of developer concentration (Y/M/C/Bk)
Measured when each job is received.

Appropriate values 16 to 192

Note Value is updated when toner is supplied after main power switch ON.

<MISC>

Other

ENV-TR (printer internal environment display)

- 1: Low humidity environment (5.8 g or less moisture)
 - 2: Normal humidity environment (5.9 to 17.3 g moisture)
 - 3: High humidity environment (17.4 g or more moisture)
-

Y, M, C, K-DRM-LF

Drum unit life (Y/M/C/Bk)
Expresses how much of life has expired (as percentage).

Appropriate values 0 to 100 (%)

Note 0% when new drum unit is inserted.

<ALARM2>

Displays alarm data.

Display	I/O	Adjust	Function	Option	Test	Counter
<ALARM-2 >			< 1/7 >		< READY >	
AA	BBBB	CCCC	DDDD	EEFFFF	GGGG	HHHHHH
AA	BBBB	CCCC	DDDD	EEFFFF	GGGG	HHHHHH
AA	BBBB	CCCC	DDDD	EEFFFF	GGGG	HHHHHH
AA	BBBB	CCCC	DDDD	EEFFFF	GGGG	HHHHHH
AA	BBBB	CCCC	DDDD	EEFFFF	GGGG	HHHHHH
AA	BBBB	CCCC	DDDD	EEFFFF	GGGG	HHHHHH
AA	BBBB	CCCC	DDDD	EEFFFF	GGGG	HHHHHH
AA	BBBB	CCCC	DDDD	EEFFFF	GGGG	HHHHHH
<div style="display: flex; justify-content: center; gap: 20px;"> ← → </div>						

F05-201-04

Item	Description	Remarks
AA	Alarm sequence number 1 to 50 (the larger the number, the older the error)	
BBBB	Date of alarm	
CCCC	Time of alarm	
DDDD	Time alarm was restored	
EE	Alarm location code (see table on next page)	
FFFF	Alarm code (see table on next page)	
GGGG	Alarm detail code (for R&D)	
HHHHHH	Total counter value when alarm is generated	

T05-201-07

COPIER>DISPLAY

EE	Alarm location code	FFFF Alarm code
04	Paper feed/conveying	0008: Side deck lifter alarm 0009: Horizontal registration detection alarm
09	Drum unit	0001: Drum life (Y) 0002: Drum life (M) 0003: Drum life (C) 0004: Drum life (K)
10	Developer unit	0001: Toner out (Bk) 0002: Toner out (C) 0003: Toner out (M) 0004: Toner out (Y)
11	Waste toner conveying	0001: Waste toner box full (intermediate copy belt)
33	Fan	0007: Paper delivery cooling fan (FM5) alarm 0012: Manual feed cooling fan (FM6) alarm 0013: Copier exhaust heat fan (FM3) alarm
34	Image position compensation control	0001: Incorrect data read (zero included in image position pattern read data) 0002: Incorrect data read (abnormal data in at least 8 of the 10 sets of image position patterns) 0003: Pattern read timeout alarm 0004: Attempt was made to compensate abnormally large slant as result of image position compensation. 0005: Attempt was made to correct large abnormally large magnification as result of image position compensation.
61	Finisher staples	0001: No staples
62	Saddle stitcher	0001: No stitch needle
72	UFR board	0001: Register access failed. 0002: Data transfer to memory failed (or timeout). 0003: Rendering error (ECI module) 0004: Rendering error (EM module) 0005: Rendering error (IE module) 0006: Rendering error (IDM module) 0007: Rendering error (LAM module) 0008: Rendering error (MI module) 0009: Rendering error (PCM module) 0010: Rendering error (PGM module) 0011: Rendering error (VII module) 0012: Rendering error (VOI module) 0013: Stores compressed image during FallBack.
73	LIPS	0001: Download overflow 0002: Insufficient work memory needed during system data processing (mainly figure processing, text processing).

T05-201-08

EE	Alarm location code	FFFF Alarm code
73	LIPS	0003: Translator was specified that was not mounted by LIPS emulation start command. 0004: Translator work memory overflow 0005: 1) System fonts full 2) Fonts full at LIPS startup (during initialization) 3) Fonts full during LIPS character set registration/graphic set registration 0006: Configuration acquiring/management error 0007: LIPS internal memory management error 0008: LIPS internal file management error 0009: Received data management error 0010: Page control error 0011: Macro management error 0012: Color management error 0013: Layout control error 0014: Font management error 0015: Character drawing error 0016: Figure drawing error 0017: Image drawing error 0018: LCD display error 0019: Text mode command layer error 0020: Vector mode command layer error 0021: Utility execution control error 0022: LIPS internal database management error 0023: LIPS internal menu control error 0024: LIPS internal boot error
74	GDI-UFR	0001: Incorrect Job Wrapper Format version 0002: Incorrect command sequence
75	PS print server unit-C1	0001: Error in PS print server unit-C1 0002: Error due to incorrect SVG analysis received from PS print server unit-C1

T05-201-09

2.2 FEEDER

The FEEDER>DISPLAY item is described below.

FEEDSIZE

	Displays the document size detected by the ADF.
Note	Displays the document size as a paper size such as A4 or LTR. For paper names, see COPIER>OPTION>CST>CST-U1, CST-U2.

COPIER>DISPLAY

3 DISPLAY (status display mode): Level 2

The COPIER>DISPLAY (Level 2) screen is shown below.

Display	I/O	Adjust	Function	Option	Test	Counter
VERSION		CCD				
USER		DPOT				
		DENS				
CST-STS						
		MISC				

F05-300-01

<VERSION>

- LANG-CS (Czech language file version)
- LANG-DA (Danish language file version)
- LANG-EL (Greek language file version)
- LANG-ES (Spanish language file version)
- LANG-ET (Estonian language file version)
- LANG-FI (Finnish language file version)
- LANG-HU (Hungarian language file version)
- LANG-KO (Korean language file version)
- LANG-NL (Dutch language file version)
- LANG-NO (Norwegian language file version)
- LANG-PL (Polish language file version)
- LANG-PT (Portuguese language file version)
- LANG-RU (Russian language file version)
- LANG-SL (Slovenian language file version)
- LANG-SV (Swedish language file version)
- LANG-TW (Chinese language (unsimplified characters) file version)
- LANG-ZH (Chinese language (simplified characters) file version)
- LANG-BU (Bulgarian language file version)
- LANG-CR (Croatian language file version)
- LANG-RM (Rumanian language file version)
- LANG-SK (Slovakian language file version)
- LANG-TK (Turkish language file version)

<CST-ST>

- WIDTH-ME (displays manual feed tray's paper width (in mm))

<DPOT>

- 2TR-PPR (output value of paper portion voltage of secondary transfer DC voltage output last)
- 2TR-BASE (output value of reference voltage of secondary transfer DC voltage output last)
- 1TR-DC-Y/M/C/K (output value of primary copy DC voltage (Y/M/C/Bk) output last)
- CHG-AC-Y/M/C/K (output value of primary charge AC voltage (Y/M/C/Bk) output last)

<DENS>

- CHG-DC-Y/M/C/K (output value of primary charge DC voltage (Y/M/C/Bk) output last)
- DEV-DC-Y/M/C/K (output value of developing DC voltage (Y/M/C/Bk) output last)
- DENS-S-Y/M/C/K (detected concentration value of sample image created during ATR control (Y/M/C/Bk))
- D-Y/M/C/K-TRGT (target value (Y/M/C/Bk) of developer concentration)
- P-SENS-P/S (detected light quantity value (P wave/S wave) of backing (ITB) during ATR control)
- D-CRNT-P/S (measured value (P wave/S wave) of dark current during ATR control)

<CCD>

- GAIN-OB (CCD odd numbered bit's BLUE gain level adjusted value –for color)
- GAIN-OG (CCD odd numbered bit's GREEN gain level adjusted value –for color)
- GAIN-OR (CCD odd numbered bit's RED gain level adjusted value –for color)
- GAIN-EB (CCD even numbered bit's BLUE gain level adjusted value –for color)
- GAIN-EG (CCD even numbered bit's GREEN gain level adjusted value –for color)
- GAIN-ER (CCD even numbered bit's RED gain level adjusted value –for color)
- GAINB-OB (CCD odd numbered bit's BLUE gain level adjusted value –for black and white)
- GAINB-OG (CCD odd numbered bit's GREEN gain level adjusted value –for black and white)
- GAINB-OR (CCD odd numbered bit's RED gain level adjusted value –for black and white)
- GAINB-EB (CCD even numbered bit's BLUE gain level adjusted value –for black and white)
- GAINB-EG (CCD even numbered bit's GREEN gain level adjusted value –for black and white)
- GAINB-ER (CCD even numbered bit's RED gain level adjusted value –for black and white)

COPIER>I/O

4 I/O (display mode)

The COPIER>I/O screen is shown below. The screen items (only the items required for market service) are described on the next page.

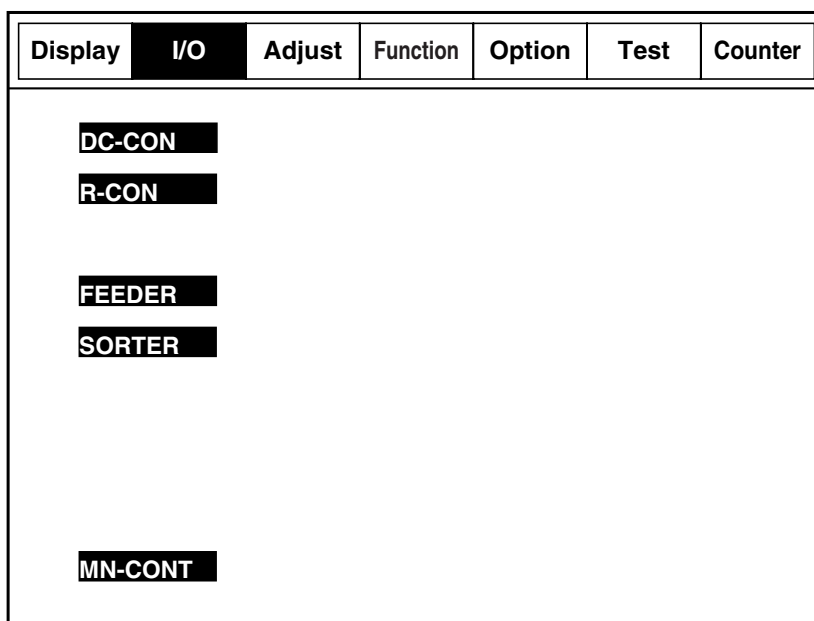

F05-400-01

<Reading the screen>

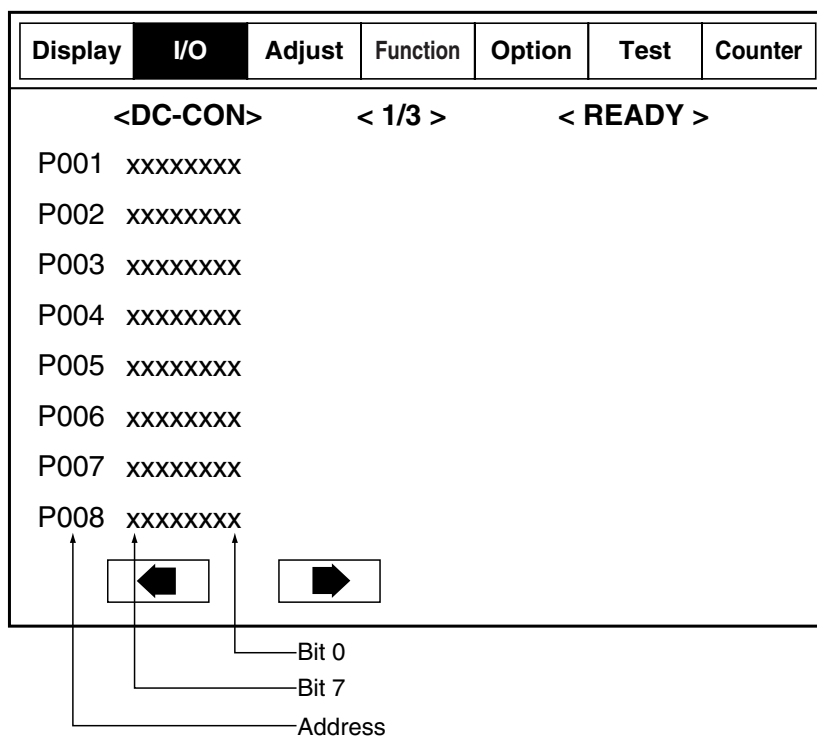

F05-400-02

<DC-CON>

Address	Bit	Symbol	Display	Remarks
P001 (input)	0		Cassette 1 size detection 0	4 bits enable 16 types of size detection (see Table T05-401-01).
	1		Cassette 1 size detection 1	
	2		Cassette 1 size detection 2	
	3		Cassette 1 size detection 3	
	4		Cassette 2 size detection 0	Size detection 0 to 3 enable 16 settings (see Table T05-401-01).
	5		Cassette 2 size detection 1	
	6		Cassette 2 size detection 2	
	7		Cassette 2 size detection 3	
	8	PS14	Cassette 1 remaining volume sensor A	1: Remaining volume is roughly half or less
	9	PS15	Cassette 1 remaining volume sensor B	1: Remaining volume is roughly 50 sheets or less
	10	PS20	Cassette 2 remaining volume sensor A	1: Remaining volume is roughly half or less
	11	PS18	Cassette 2 remaining volume sensor B	1: Remaining volume is roughly 50 sheets or less
	12	PS7	Cassette 1 paper sensor	1: ON
	13	PS19	Cassette 2 paper sensor	1: ON
	14	PS10	Manual paper feed paper sensor	1: ON
	15	PS9	Manual paper feed last paper sensor	1: ON

4-ream actuator

	Cassette paper size	Inner		Front	
		Bit 3	Bit 2	Bit 1	Bit 0
1	STMT R	0	1	1	1
2	LTR	1	0	1	1
3	LTR R	0	1	0	1
4	LGL	1	0	1	0
5	11 × 17	1	1	0	1
6	A5 R	0	1	1	0
7	A4	0	0	1	1
8	A4 R	1	0	0	1
9	A3	0	1	0	0
10	B5	0	0	1	0
11	B5 R	0	0	0	1
12	B4	0	0	0	0
13	12 × 18	1	0	0	0
14	U1	1	1	0	0
15	U2	1	1	1	0
16	No cassette	1	1	1	1

0: Actuator pressed

T05-401-01

COPIER>I/O

Address	Bit	Symbol	Display	Remarks
P002 (output)	0		Developing bias mode (Y)	0: Rectangular wave
	1		Developing bias mode (M)	0: Rectangular wave
	2		Developing bias mode (C)	0: Rectangular wave
	3		Developing bias mode (K)	0: Rectangular wave
	4		For R&D	
	5		For R&D	
	6		For R&D	
	7		For R&D	
	8		High-pressure remote	0: High pressure ON permitted
	9		For R&D	
	10		For R&D	
	11		Drum ITB motor operation direction	0: Forward
	12		Drum ITB motor	0: ON
	13		Fixing exhaust heat fan half-speed	1: Half-speed
	14		Cleaner fan half-speed	1: Half-speed
15		Power cooling fan half-speed	0: Half-speed	
P003 (output)	0		Cassette 1 paper feed solenoid	1: ON
	1		Cassette 2 paper feed solenoid	1: ON
	2		Manual paper feed unit paper feed solenoid	1: ON
	3		Paper delivery path switching solenoid 1	0: Back side paper delivery, 1: Front side paper delivery
	4		For R&D	
	5		For R&D	
	6		For R&D	
	7		For R&D	
	8		Transparency detection LED	1: ON
	9		For R&D	
	10		For R&D	
	11		For R&D	
	12		For R&D	
	13		For R&D	
	14		For R&D	
15		For R&D		
P004 (input)	0		For R&D	
	1		For R&D	
	2		For R&D	
	3		For R&D	
	4		For R&D	
	5		For R&D	
	6		For R&D	

T05-401-02

Address	Bit	Symbol	Display	Remarks
	7		For R&D	
	8		For R&D	
	9		Two-sided PCB connection	0: Connected
	10		Paper delivery cooling fan lock detection	0: Running, 1: Stopped (only operates during two-sided copying)
	11		Copier exhaust heat fan lock detection	0: Running, 1: Stopped
	12		Manual feed cooling fan lock detection	0: Running, 1: Stopped
	13		Power cooling fan lock detection	0: Running, 1: Stopped
	14		Cleaner fan lock detection	0: Running, 1: Stopped
	15		Fixing exhaust heat fan lock detection	0: Running, 1: Stopped
P005 (input)	0		For R&D	
	1		For R&D	
	2		Cassette pedestal connection	0: Connected
	3		Cassette pedestal power ready	0: Ready
	4	PS5	Fixing conveyor unit OPEN/CLOSED detection	1: CLOSED
	5		Fixing heater enable	0: Enabled
	6		For R&D	
	7	PS13	Delivery vertical path cover detection	0: OPEN, 1: CLOSED
	8	PS28	Manual feed unit OPEN/CLOSED detection	1: CLOSED
	9	PS8	Center paper delivery tray full sensor	1: Full
	10	PS11	Paper feed vertical path cover OPEN/ CLOSED sensor	1: CLOSED
	11	PS23	Front cover OPEN/CLOSED sensor	1: CLOSED
	12		For R&D	
	13		Drum ITB motor lock detection	0: Running
	14		TRIAC short detection	0: Error
	15		Fixing unit high temperature detection	1: Error
P006 (output)	0		For R&D	
	1		For R&D	
	2		For R&D	
	3		For R&D	
	4		24-V ON	0: ON
	5		Secondary transfer positive/negative switching	0: Positive output, 1: Negative output
	6		Drum unit operation signal	1: ON
	7		Cassette heater (for cassette 1/2) ON	0: Heater ON, 1: Heater OFF
	8		For R&D	
	9		For R&D	
	10		For R&D	

T05-401-03

COPIER>I/O

Address	Bit	Symbol	Display	Remarks
	11		For R&D	
	12		For R&D	
	13		Paper delivery cooling fan full speed	1: Full speed (during two-sided output)
	14		For R&D	
	15		Copier exhaust heat fan full speed	1: Full speed (during output when temperature inside copier is 30°C or more)
P007 (input)	0	PS17	Cassette 2 retry paper sensor	1: ON
	1	PS16	Cassette 1 retry paper sensor	1: ON
	2	PS26	Resist sensor	1: ON
	3	PS27	Fixing inlet sensor	1: ON
	4	PS25	Fixing paper delivery sensor	1: ON
	5	PS12	Face-down paper delivery sensor 1	1: ON
	6	PS21	Two-sided resist sensor	1: ON
	7	PS24	Two-sided paper feed sensor	1: ON
	8	PS6	Face-down paper delivery sensor 2	1: ON
	9	PS22	Two-sided horizontal resist sensor	1: ON
	10		Transparency sensor (front)	1: ON
	11		Transparency sensor (inner)	1: ON
	12		For R&D	
	13		For R&D	
	14		For R&D	
	15		For R&D	
P008 (output)	0		Paper delivery vertical path motor current switching 0	See separate Table T05-401-08.
	1		Paper delivery vertical path motor current switching 1	
	2		Face-down paper delivery motor current switching 0	See separate Table T05-401-08.
	3		Face-down paper delivery motor current switching 1	
	4		Manual feed cooling fan	1: ON
	5		Cleaner fan	1: ON
	6		Fixing exhaust heat fan	1: ON
	7		Power cooling fan	0: ON
	8		Transparency sensor (front) gain switching	1: Gain large, 0: Gain small
	9		Transparency sensor (inner) gain switching	1: Gain large, 0: Gain small
	10		For R&D	
	11		For R&D	
	12		For R&D	
	13		For R&D	
	14		For R&D	
	15		For R&D	

T05-401-04

Address	Bit	Symbol	Display	Remarks
P009 (input/ output)	0		Two-sided resist clutch	1: ON two-sided
	1		Two-sided paper feed clutch	1: ON two-sided
	2		Paper delivery path switching solenoid 2	1: ON
	3		For R&D	
	4		For R&D	
	5		For R&D	
	6		Horizontal registration voltage down	1: Voltage down two-sided
	7		Horizontal registration excitation	0: Excitation ON (voltage down status)
	8		For R&D	
	9		For R&D	
	10		For R&D	
	11		For R&D	
	12		For R&D	
	13		For R&D	
	14		For R&D	
15		For R&D		
P010 to P018 (for R&D)	0 to 7		For R&D	
P019 (input)	0		Cassette 3 size detection 0	Size detection 0 to 3 enable 16 settings (see Table T05-401- 01).
	1		Cassette 3 size detection 1	
	2		Cassette 3 size detection 2	
	3		Cassette 3 size detection 3	
	4		Cassette 4 size detection 0	Size detection 0 to 3 enable 16 settings (see Table T05-401- 01).
	5		Cassette 4 size detection 1	
	6		Cassette 4 size detection 2	
P020 (input)	7		Cassette 4 size detection 3	
	0		Cassette 3 remaining volume detection A	1: Remaining volume is roughly half or less
	1		Cassette 3 remaining volume detection B	1: Remaining volume is roughly 50 sheets or less
	2		Cassette 4 remaining volume detection A	1: Remaining volume is roughly half or less
	3		Cassette 4 remaining volume detection B	1: Remaining volume is roughly 50 sheets or less
	4		Right cover OPEN/CLOSED detection	1: CLOSED
	5	PS5D	Deck attachment	0: Deck released from copier
6	PS8D	Deck paper volume sensor top	0: No paper	
7		Deck connection signal detection	1: Connected	

T05-401-05

COPIER>I/O

Address	Bit	Symbol	Display	Remarks
P021 (input)	0		Deck LED switch	0: LED switch pressed
	1	PS4D	Deck lifter sensor	1: Lifter at paper feed position
	2		Deck lifter motor error detection	0: Lifter error detected
	3	PS3D	Deck lifter upper limit sensor	1: Lifter has reached upper limit
	4	PS7D	Deck paper volume sensor bottom	0: No paper
	5	PS6D	Deck paper feed sensor	1: Paper
	6		Deck lifter lower limit sensor	1: Lifter has reached lower limit
	7	PS9D	Deck open sensor	0: Storage compartment is open
P022 (output)	0		Paper feed 3 solenoid	1: ON
	1		Paper feed 4 solenoid	1: ON
	2	CL2D	Deck paper feed clutch	1: ON
	3	SL1D	Deck paper feed solenoid	1: ON
	4		Deck lifter motor	0: Lifter motor ON
	5		Deck lifter motor DOWN	1: Lift DOWN, L: Lift UP
	6	SL2D	Deck paper compartment OPEN SL	1: SL ON
	7		Deck paper compartment button LED	1: LED lit
P023 to P025 (for R&D)	0 to 7		For R&D	
P026 (input/ output)	0		For R&D	
	1		For R&D	
	2		For R&D	
	3		Cassette heater (for cassette 3/4) ON	0: Heater ON, 1: Heater OFF
	4		For R&D	
	5		For R&D	
	6		For R&D	
	7		For R&D	
P027 (input/ output)	0		For R&D	
	1		For R&D	
	2		For R&D	
	3		For R&D	
	4		For R&D	
	5		For R&D	
	6		Deck motor current switching signal 0	See Table T05-401-09.
	7		Deck motor current switching signal 1	See Table T05-401-09.

T05-401-06

Address	Bit	Symbol	Display	Remarks
P028 (input/ output)	0		Cassette 3 paper feed current switching signal 0	See pulse motor current setting table (Table T05-401-08).
	1		Cassette 3 paper feed current switching signal 1	
	2		Cassette 4 paper feed current switching signal 0	See pulse motor current setting table (Table T05-401-08).
	3		Cassette 4 paper feed current switching signal 1	
	4		For R&D	
	5		For R&D	
	6		For R&D	
	7		For R&D	
P029 (input/ output)	0		Cassette 3 retry sensor	1: Paper
	1		Cassette 4 retry sensor	1: Paper
	2	PS2D	Deck no paper detection	1: Paper
	3	PS1D	Deck outlet paper sensor	1: Paper
	4		Cassette 3 paper detection	1: Paper
	5		Cassette 4 paper detection	1: Paper
	6		Pedestal model detection	1: Plain pedestal, 0: Cassette pedestal
	7	CL1D	Deck conveyor CL	1: CL ON

T05-401-07

0	1	Pulse motor current setting
0	0	100%
1	0	70%
0	1	31%
1	1	0%

T05-401-08

0	1	Paper deck pulse motor current setting
0	0	100%
1	0	70%
0	1	50%
1	1	35%

T05-401-09

COPIER>I/O

<R-CON>

Address	Bit	Symbol	Display	Remarks
P001 (input/ output)	0		Image leading edge signal	0: Image leading edge detected
	1		12 V, 24 V	0: 12 V supply, 1: 24 V supply
	2		For R&D	
	3		Optical motor clock signal (input)	1: Optical motor running
	4		Optical motor clock signal (output)	1: Optical motor running
	5		For R&D	
	6		For R&D	
	7		Size detection sensor drive signal	1: Document size detected
P002 (input)	0		For R&D	
	1		For R&D	
	2		Size detection signal (AB/inch)	0: Detect document
	3		Size detection signal (inch)	0: Detect document
	4		For R&D	
	5		For R&D	
	6		For R&D	
	7		For R&D	
P003: For R&D				
P004 (input)	0		For R&D	
	1		For R&D	
	2		For R&D	
	3		For R&D	
	4		Pressure platen CLOSED detection signal	1: Detect pressure platen closed 30°
	5		Optical home position detection signal	1: Detect optical home position
	6		For R&D	
	7		For R&D	

P005 to P007: For R&D

T05-401-10

Address	Bit	Symbol	Display	Remarks
P008 (output)	0		Document illumination lamp lit signal	1: Document illumination lamp lit
	1		CCD drive signal	1: CCD drive
	2		For R&D	
	3		For R&D	
	4		For R&D	
	5		For R&D	
	6		For R&D	
	7		For R&D	
P009: For R&D				

T05-401-11

COPIER>I/O

<FEEDER>

Address	Bit	Symbol	Display	Remarks
P001 (input)	0	SR5	Reverse paper delivery resist sensor	1: ON
	1	SR4	Reverse paper delivery inlet sensor	1: ON
	2	SR3	Separation sensor	1: ON
	3		—	—
	4		—	—
	5		—	—
	6		—	—
	7		—	—
P002 (for R&D)	0 to 7		—	
P003 (input)	0	U505	Reverse outlet sensor	1: ON
	1	U502	Resist front sensor	1: ON
	2	U503	Document set sensor	1: ON
	3	U504	Final document detection sensor	1: ON
	4		—	—
	5		—	—
	6		—	—
	7		—	—
P004 (input)	0		—	
	1	SR1	Conveyor motor clock sensor	Alternates between 1 and 0 when motor is running.
	2	SR7	Reverse paper delivery motor clock sensor	Alternates between 1 and 0 when motor is running.
	3		—	
	4		—	
	5		—	
	6		—	
P005 (for R&D)	0 to 7		—	
P006 (output)	0		Separation motor reverse operation	1: ON
	1		Separation motor forward operation	1: ON
	2		Separation motor PWM	1: ON
	3		—	—
	4		Conveyor motor PWM	1: ON
	5		Brake	1: ON
	6		Paper delivery motor PWM	1: ON
7		—	—	

T05-401-12

Address	Bit	Symbol	Display	Remarks
P007 (output)	0		–	–
	1		Document display LED	1: Lit
	2		LED1	0: Lit (flashes when paper doesn't go through)
	3		LED2	0: Lit
	4		Conveyor motor reverse operation	1: ON
	5		Conveyor motor forward operation	1: ON
	6		Paper delivery motor reverse operation	1: ON
	7		Paper delivery motor forward operation	1: ON
P008 (input)	0		–	–
	1		–	–
	2		Push switch	1: ON
	3	SR8	Reverse paper delivery unit cover sensor	0: OPEN
	4	SR2	Paper feed unit cover sensor	0: OPEN
	5	SR6	ADF OPEN/CLOSED sensor	0: OPEN
	6		–	–
	7		–	–
P009 (for R&D)	0 to 7		–	–
P010 (input)	0		DIP SW bit 1	1: ON
	1		DIP SW bit 2	1: ON
	2		DIP SW bit 3	1: ON
	3		DIP SW bit 4	1: ON
	4		DIP SW bit 5	1: ON
	5		DIP SW bit 6	1: ON
	6		DIP SW bit 7	1: ON
	7		DIP SW bit 8	1: ON

T05-401-13

COPIER>I/O

<SORTER>

<Finisher M1>

Address	Bit	Symbol	Display	Remarks
P001 (input)	0	S10D	Stack tray home position detection	1: Home position
	1	S2D	Inlet paper detection	1: Paper
	2	S12D	Stack tray lower limit detection	1: Lower limit
	3	S13D	Stack tray upper limit detection	1: Upper limit
	4	S11D	Stack tray paper detection	1: Paper
	5	S4D	Copier, finisher connection detection	1: Connection released
	6	S5D	Processing tray paper detection	1: Paper
	7	S6D	Return roller home position detection	1: Home position
P002 (for R&D)	0 to 7		–	–
P003 (input)	0	S6D	Front junction plate home position junction detection	1: Home position
	1	S7D	Rear junction plate home position junction detection	1: Home position
	2	S8D	Bundle paper delivery lever home position detection	0: Home position
	3	–	–	–
	4	S18D	Staple cartridge detection	1: No cartridge
	5	S15D	Staple detection	1: No staples
	6	S17D	Stapling home position detection	0: Home position
	7	S16D	Staple leading edge detection	1: No staple leading edge
P004 (input)	0	S1D	Paper delivery motor clock detection	1: Startup detection
	1	–	–	–
	2	–	–	–
	3	–	–	–
	4	–	–	–
	5	–	–	–
	6	–	–	–
	7	–	–	–

T05-401-14

Address	Bit	Symbol	Display	Remarks
P005 (input/ output)	0	M5D1	Stack tray UP/DOWN motor operation 1 (output)	1: UP
	1	—	—	—
	2	M5D2	Stack tray UP/DOWN motor reverse operation 1 (output)	1: DOWN
	3	—	—	—
	4	S9D	Stack tray UP/DOWN motor clock detection	1: Startup detection
	5	S14D	Staple safety detection	1: Obstruction
	6	—	—	—
	7	—	—	—
P006 (output)	0	—	—	—
	1	—	—	—
	2	—	Front junction motor junction signal (output)	1: Permit
	3	—	Rear junction motor permission signal (output)	1: Permit
	4	—	—	—
	5	—	—	—
	6	M6DA	Staple motor operation 2 (output)	0: Forward
	7	M6DB	Staple motor reverse operation 2 (output)	0: Reverse
P007 (output)	0	M6DA	Staple motor operation 1 (output)	0: Forward
	1	M6DB	Staple motor reverse operation 1 (output)	0: Reverse
	2	M5D1	Stack tray UP/DOWN motor reverse operation 2 (output)	1: UP
	3	M5D2	Stack motor UP/DOWN motor reverse operation 2 (output)	1: DOWN
	4	—	—	—
	5	—	—	—
	6	—	—	—
	7	—	Paper delivery motor OFF signal (output)	0: Current ON
P008 (input/ output)	0	—	Push switch (output)	0: ON
	1	—	—	—
	2	—	—	—
	3	—	—	—
	4	—	—	—
	5	—	—	—
	6	—	—	—
	7	—	24VP detection	—

T05-401-15

COPIER>I/O

Address	Bit	Symbol	Display	Remarks
P009	0 to 7	–	–	–
(for R&D)				
P010	0	–	Pa per delivery motor current switching (output)	1: Current low, 0: Current high
	1	–	Bundle processing motor current switching 1 (output)	1: Current low, 0: Current high
	2	–	Bundle processing motor current switching 2 (output)	1: Current low, 0: Current medium
	3	–	Front matching motor current switching (output)	1: Current low, 0: Current high
	4	–	Rear matching motor current switching (output)	1: Current low, 0: Current high
	5	–	LED1	0: ON
	6	–	LED2	0: ON
	7	–	LED3	0: ON
P011	0	–	DIPSW1 bit 1	0: ON
(input)	1	–	DIPSW1 bit 2	0: ON
	2	–	DIPSW1 bit 3	0: ON
	3	–	DIPSW1 bit 4	0: ON
	4	–	DIPSW1 bit 5	0: ON
	5	–	DIPSW1 bit 6	0: ON
	6	–	DIPSW1 bit 7	0: ON
	7	–	DIPSW1 bit 8	0: ON

T05-401-16

<Finisher N1/saddle finisher N2 (finisher unit)>

Address	Bit	Symbol	Display	Remarks
P001	0	–	–	–
(output)	1	–	–	–
	2	M8	Second feed motor A phase output	–
	3	M8	Second feed motor B phase output	–
	4	M4	Staple mover motor B phase output	–
	5	M4	Staple mover motor A phase output	–
	6	M3	Matching motor B phase output	–
	7	M3	Matching motor A phase output	–
	8 to 15	–	–	–
P002	0	M5	Tray UP/DOWN motor PWM	–
(output)	1	M2	Paper delivery motor PWM	–
	2	M7	Rotary motor PWM	–
	3	–	–	–
	4	–	–	–
	5	–	–	–
	6	M5	Tray UP/DOWN motor DOWN drive output	1: DOWN
	7	M5	Tray UP/DOWN motor UP/DOWN drive output	1: UP
	8 to 15	–	–	–
P003	0	–	–	–
(output)	1	–	LED2 lighting signal output	0: Lit
	2	–	–	–
	3	PS1	Height sensor (input)	–
	4	–	LED1 lighting signal output	1: Lit
	5	PS1	Height sensor external clock (input)	–
	6	–	–	–
	7	–	–	–
	8 to 15	–	–	–
P004	0	–	–	–
(output)	1	–	24 V output interruption detection signal	–
	2	–	–	–
	3	–	–	–
	4	–	–	–
	5	–	–	–
	6	–	–	–
	7	–	–	–
	8 to 15	–	–	–

T05-401-17

COPIER>I/O

Address	Bit	Symbol	Display	Remarks
P005 (output)	0	M9	Inlet feed motor A phase output	—
	1	M9	Inlet feed motor B phase output	—
	2	—	—	—
	3	—	—	—
	4	—	—	—
	5	—	—	—
	6	—	—	—
	7	—	—	—
	8 to 15	—	—	—
P006 (output)	0	—	Staple tray paper detection signal	0: Paper
	1	—	—	—
	2	M1	First feed motor A phase (output)	—
	3	M1	First feed motor B phase (output)	—
	4	M8	Second feed motor clock input	—
	5	M9	Inlet feed motor clock input	—
	6	M1	First feed motor clock input	—
	7	—	Paper delivery motor clock detection signal	—
	8 to 15	—	—	—
P007 (output)	0	—	—	—
	1	—	—	—
	2	—	—	—
	3	—	—	—
	4	—	—	—
	5	M5	Tray UP/DOWN motor clock detection signal 1	—
	6	M5	Tray UP/DOWN motor clock detection signal 2	—
	7	M7	Rotary motor clock detection signal	—
	8 to 15	—	—	—
P008 (output)	0	—	Stacker unit EEPROM clock	—
	1	—	Stacker unit EEPROM data output	—
	2	—	Stacker unit EEPROM CS	—
	3	—	*LWR (input/output)	—
	4	—	*HWR (input/output)	—
	5	—	*RD (input/output)	—
	6	—	*AS (input/output)	—
	7	—	Stacker unit EEPROM data input (input)	—
	8 to 15	—	—	—

T05-401-18

Address	Bit	Symbol	Display	Remarks
P009 (output)	0	–	Buffer path input paper detection signal	0: Paper
	1	–	Paper delivery paper detection signal	1: Paper
	2	–	Buffer path paper detection signal	0: Paper
	3	–	Input detection signal	0: Paper
	4	PI7	Staple drive home position detection signal	1: Home position
	5	–	–	–
	6	–	–	–
	7	–	–	–
	8 to 15	–	–	–
P010 (for R&D)	0 to 15	–	–	–
P011 (for R&D)	0 to 15	–	–	–
P012 (output)	0	–	Stapler connection detection signal	1: Connected
	1	MS7	Staple cartridge detection	1: Cartridge
	2	–	–	–
	3	–	No staple detection signal	1: Staple
	4	–	–	–
	5	PI11	Tray 1 detection signal	1: Paper
	6	PI12	Tray 2 detection signal	1: Paper
	7	–	–	–
	8 to 15	–	–	–
P013 (not used)	0 to 15	–	–	–
P014 (not used)	0 to 15	–	–	–
P015 (output)	0	–	Push switch 3	–
	1	–	Push switch 2	–
	2	–	–	–
	3	PI22	Staple mover position detection signal	1: Home position
	4	PI6	Matching plate home position detection signal	1: Home position
	5	PI8	Tray home position detection signal	1: Home position
	6	PI5	Shutter OPEN detection signal	1: OPEN
	7	PI18	Rotary guide OPEN detection signal	1: OPEN
	8 to 15	–	–	–

T05-401-19

COPIER>I/O

Address	Bit	Symbol	Display	Remarks
P016 (output)	0	–	DIP SW3 bit 1	1: ON
	1	–	DIP SW3 bit 2	1: ON
	2	–	DIP SW3 bit 3	1: ON
	3	–	DIP SW3 bit 4	1: ON
	4	–	DIP SW3 bit 5	1: ON
	5	–	DIP SW3 bit 6	1: ON
	6	–	DIP SW3 bit 7	1: ON
	7	–	DIP SW3 bit 8	1: ON
	8 to 15	–	–	–
P017 (output)	0	–	Joint detection signal	1: Connected
	1	–	Fr ont top cover OPEN/CLOSED detection signal	1: CLOSED
	2	MS5	Saddle unit connection detection signal	–
	3	MS5	Tray upper limit detection switch signal	1: Upper limit
	4	MS3	Tray safety switch signal	0: Safe
	5	–	Front top cover OPEN/CLOSED detection switch signal	0: CLOSED
	6	MS4	Shutter CLOSED detection switch signal	1: CLOSED
	7	MS2	Rotary guide CLOSED detection switch signal	1: CLOSED
8 to 15	–	–	–	
P018 (output)	0	M7	Rotary motor forward drive output	1: Forward
	1	M7	Rotary motor reverse drive output	1: Reverse
	2	–	–	–
	3	–	–	–
	4	M2	Paper delivery motor reverse drive output	1: Reverse
	5	M2	Paper delivery motor forward drive output	1: Forward
	6	M6	Staple motor reverse drive output	1: Reverse
	7	M6	Staple motor forward drive output	1: Forward
8 to 15	–	–	–	
P019 (output)	0	–	First feed motor OFF	1: OFF
	1	–	–	–
	2	M9	Inlet feed motor connectivity switching 2	0: During drive
	3	M9	Inlet feed motor connectivity switching 1	0: During drive
	4	M8	Second feed motor current switching 2	0: During drive
	5	M8	Second feed motor current switching 1	0: During drive
	6	M1	First feed motor current switching 2	0: During drive
	7	M1	First feed motor current switching 1	0: During drive
8 to 15	–	–	–	

T05-401-20

Address	Bit	Symbol	Display	Remarks
P020 (output)	0	–	–	–
	1	–	–	–
	2	–	–	–
	3	–	–	–
	4	–	–	–
	5	PS1	Height sensor ON/OFF	–
	6	M4	Staple mover motor current switching	0: During drive
	7	M3	Matching motor current switching	0: During drive
	8 to 15	–	–	–
P021 (output)	0	–	Belt retraction solenoid drive signal	1: ON
	1	–	Buffer outlet solenoid drive signal	1: ON
	2	–	–	–
	3	–	Buffer inlet solenoid drive signal	1: ON
	4	–	Flapper solenoid drive signal	1: ON
	5	–	Paddle solenoid drive signal	1: ON
	6	–	Solenoid timer output	–
	7	–	Retraction solenoid drive signal	1: ON
	8 to 15	–	–	–

T05-401-21

COPIER>I/O

<Saddle finisher N2 (saddle unit)>

Address	Bit	Symbol	Display	Remarks
P023 (output)	0	M6S	Stitch motor (inner) forward drive output	0: Forward
	1	M6S	Stitch motor (inner) reverse drive output	0: Reverse
	2	M7S	Stitch motor (front) forward drive output	0: Forward
	3	M7S	Stitch motor (front) reverse drive output	0: Reverse
	4	M2S	Paper folder motor forward drive output	0: Forward
	5	M2S	Paper folder motor reverse drive output	0: Reverse
	6	SL1S	First deflecting plate solenoid drive signal	1: ON
	7	SL2S	Second deflecting plate solenoid drive signal	1: ON
	8 to 15	–	–	–
P024 (output)	0	–	–	–
	1	–	–	–
	2	–	–	–
	3	–	–	–
	4	–	–	–
	5	–	Conveyor plate-adjointing solenoid drive signal	1: ON
	6	–	–	–
	7	–	Paper positioning plate motor current switching	0: During drive
	8 to 15	–	–	–
P025 (output)	0	–	24 V output interruption detection signal	1: Down
	1	PI15S	Paper push plate leading edge position signal	0: Leading edge
	2	PI11S	Paper delivery detection signal	0: Paper
	3	–	–	–
	4	–	–	–
	5	–	–	–
	6	–	–	–
	7	–	–	–
	8 to 15	–	–	–
P026 (output)	0	PI4S	Paper folder motor clock detection signal	–
	1	PI1S	Paper push plate motor clock detection signal	–
	2	PI14S	Paper push plate home position detection signal	1: Home position
	3	PI5S	Matching plate home position detection signal	0: Home position
	4	–	–	–
	5	–	–	–

T05-401-22

Address	Bit	Symbol	Display	Remarks
	6	–	–	–
	7	–	–	–
	8 to 15	–	–	–
P027 (output)	0	–	Paper positioning plate home position detection signal	0: Home position
	1	PI16S	Stitcher storage detection signal	0: Stored
	2	–	PUSH SW2 ON/OFF	–
	3	PI17S	Vertical path paper detection signal	1: Paper
	4	PI12S	Crescent roller phase detection signal	0: Home position
	5	PI13S	Guide home position detection signal	0: Home position
	6	–	–	–
	7	–	–	–
	8 to 15	–	–	–
P028 (output)	0	M4S	Paper positioning plate motor A phase output	–
	1	M4S	Paper positioning plate motor B phase output	–
	2	M8S	Paper push plate motor PWM	–
	3	M1S	Feed motor current switching	0: Drive
	4	M1S	Feed motor A phase output	–
	5	M1S	Feed motor B phase output	–
	6	–	–	–
	7	M8S	Paper push plate motor reverse drive output	0: Reverse
	8 to 15	–	–	–
P029 (output)	0	M5S	Matching motor A phase output	–
	1	M5S	Matching motor B phase output	–
	2	M2S	Paper folder motor PWM	–
	3	M8S	Paper push plate motor forward drive output	0: Forward
	4	M3S	Guide motor A phase output	–
	5	M3S	Guide motor B phase output	–
	6	M3S	Guide motor current switching	0: Drive
	7	M5S	Matching motor current switching	0: Drive
	8 to 15	–	–	–
P030 (output)	0	PI19S	Second paper sensor paper detection signal	0: Paper
	1	PI20S	Third paper sensor paper detection signal	0: Paper
	2	MS5S	Stitch operation home position detection signal 2	1: Home position
	3	MS7S	Stitch operation home position detection signal 1	1: Home position

T05-401-23

COPIER>I/O

Address	Bit	Symbol	Display	Remarks
	4	MS8S	Paper positioning plate paper detection signal	0: Paper
	5	MS6S	Tray paper detection signal	0: Paper
	6	MS18S	First paper sensor paper detection signal	0: Paper
	7	–	–	–
	8 to 15	–	–	–
P031 (output)	0	–	Matching plate home position sensor connector connection detection	1: Connected
	1	–	Paper fold home position sensor connector connection detection	1: Connection
	2	–	Paper delivery cover sensor connector connection detection	1: Connected
	3	–	Front bottom cover OPEN/CLOSED sensor connector connection detection	1: Connected
	4	–	Paper positioning plate home position sensor connector connection detection	1: Connected
	5	–	Paper fold home position detection signal	0: Home position
	6	–	–	–
	7	–	–	–
	8 to 15	–	–	–
P032	0 to 15	–	–	–
P033 (output)	0	MS4S	No staple detection signal 2	1: Staple
	1	MS6S	No staple detection signal 1	1: Staple
	2	MS1S	Inlet cover OPEN detection switch signal	0: CLOSED
	3	–	Front bottom cover OPEN detection switch signal	0: CLOSED
	4	PI3S	Paper delivery cover OPEN switch signal	0: CLOSED
	5	–	Front bottom cover OPEN detection signal	1: CLOSED
	6	PI9S	Inlet cover OPEN detection signal	1: CLOSED
	7	MS3S	Paper delivery cover OPEN detection switch signal	1: CLOSED
	8 to 15	–	–	–
P034 (output)	0	–	DIP SW1 bit 1	0: ON
	1	–	DIP SW1 bit 2	0: ON
	2	–	DIP SW1 bit 3	0: ON
	3	–	DIP SW1 bit 4	0: ON
	4	–	DIP SW1 bit 5	0: ON
	5	–	DIP SW1 bit 6	0: ON
	6	–	DIP SW1 bit 7	0: ON
	7	–	DIP SW1 bit 8	0: ON
	8 to 15	–	–	–
P035 to P050	–	–	–	–

T05-401-24

<MN-CON>

Address	Bit	Symbol	Display	Remarks
P001 (output)	0	Gpdata	PWR1	1: During normal operation
	1		PWR2	1: During normal operation
	2		For R&D	Alternates between 1 and 0 every 50 msec
	3		For R&D	
	4		Cooling fan ON	Cooling fan control
P002	0 to 16		For R&D	
P003 (output)	10	GPO	Paper feed count (for coin vendor, assistance)	
	11		Paper delivery count (for coin vendor, assistance)	
	12		LCD backlight control	0: OFF, 1: ON
P004 (input)	0	GPI	SRAM board detection	0: YES, 1: NO
	1		For R&D	
	2		For R&D	
	3		Operation permission (key switch)	0: Permitted, 1: Not permitted
	4		Operation permission (control card)	0: Permitted, 1: Not permitted
	5		Operation permission (coin vendor)	0: Permitted, 1: Not permitted
P005	0 to 7		For R&D	
P006 (input)	8		Open interface control (PRDY signal)	0: Ready, 1: Not ready
	9		Open interface setting	Mode 0
	10		Open interface setting	Mode 1
	11		For R&D	
	12		For R&D	
	13		For R&D	
	14		Open interface board detection	0: YES, 1: NO
	15		Open interface board control (CRDY)	0: Ready, 1: Not ready
P007 (input)	16		Fax option	0: Connected, 1: Not connected
P008 (input)	4		Printer power ready	0: Ready, 1: Not ready
	5		For R&D	
	6		For R&D	
	7		For R&D	
	8		For R&D	
	9		Scanner power ready	0: Ready, 1: Not ready

T05-401-25

COPIER>I/O

Address	Bit	Symbol	Display	Remarks
P009	5		PCPRDY	0: Ready, 1: Not ready
(output)	6		For R&D	
	7		For R&D	
	8		For R&D	
	9		For R&D	
	10		For R&D	
	11		Controller power ready	0: Ready, 1: Not ready

T05-401-26

5 ADJUST (adjustment mode): Level 1

5.1 COPIER

The COPIER>ADJUST (Level 1) screen is shown below.

Display	I/O	Adjust	Function	Option	Test	Counter
		BLANK				
		ADJ-XY				
		CCD		FEED-ADJ		
		LASER		CST-ADT		
		IMG-REG				
				MISC		

F05-501-01

COPIER>ADJUST

<ADJ-XY>

Used to adjust the image read start position.

ADJ-X

Used to adjust the optical image leading edge position (image read start position in the sub-scanning direction).

- Adjustment method
- If the image's blank width is larger than the standard value, the setting value should be decreased.
 - If areas outside the document are also copied, the setting value should be increased.
 - Increasing the setting value by 1 moves the image read start position by 0.1 mm in the direction of the trailing edge. (The image read range moves in the direction of the trailing edge.)
 - If you have cleared the reader controller PCB's RAM or replaced the reader controller PCB, enter the value on the service label.

Adjustment range **220 to 320 (Value at time of factory shipment: Factory-adjusted value)**
(Value after RAM clear: 265)

Caution 1 After changing the setting value of this item, execute the following:

- COPIER>FUNCTION>CCD>SH-PS-ST

Caution 2 After changing the setting value of this item, enter the new value on the service label.

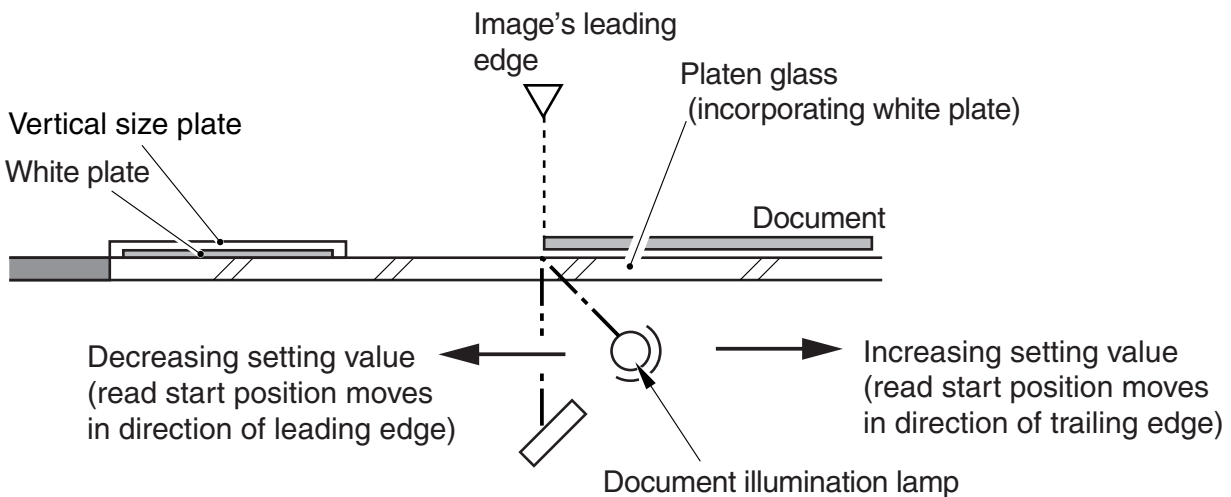

F05-501-02

ADJ-Y

Used to adjust the CCD's read start cell position (image read start position in the main scanning direction).

Adjustment method

- If the image's blank width is larger than the standard value, the setting value should be decreased.
- If areas outside the document are also copied, the setting value should be increased.
- Increasing the setting value by 1 moves the image read start position by 0.1 mm toward you. (The image read range moves toward you.)
- If you have cleared the reader controller PCB's RAM or replaced the reader controller PCB, enter the value on the service label.

Adjustment range **0 to 1000 (Value at time of factory shipment: Factory-adjusted value)**
(Value after RAM clear: 58)

Caution After changing the setting value of this item, enter the new value on the service label.

Decreasing setting value
(read start position moves
away from you)

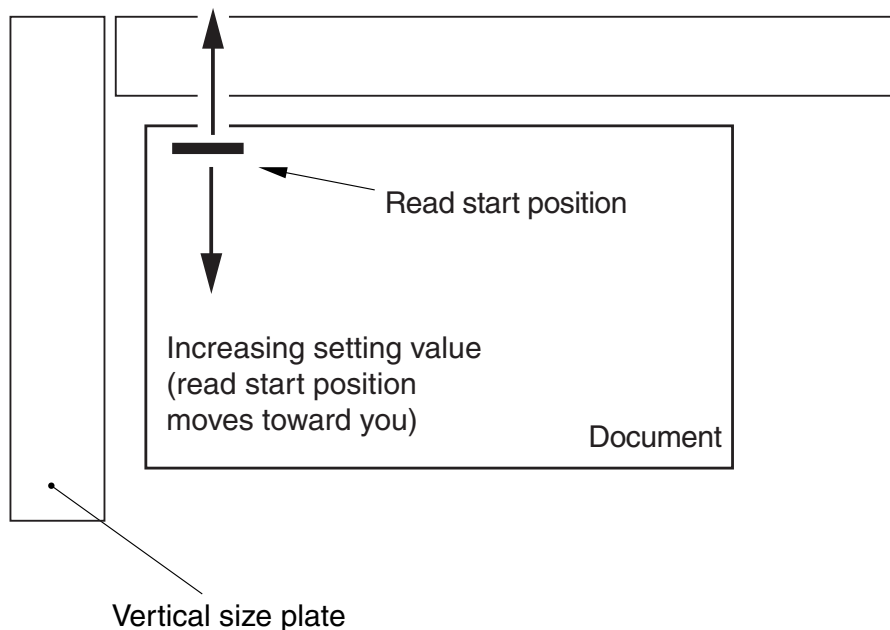

F05-501-03

COPIER>ADJUST

ADJ-S

Used to enter the adjusted value of the optical shading measurement position.

- If white or black lines appear in the image after executing COPIER>FUNCTION>CCD>SH-PS-ST (to automatically adjust the shading measurement position), you can adjust the shading measurement position manually by changing the setting value.
- Decreasing the setting value by 1 moves the shading measurement position by 0.1 mm in the direction of the leading edge.
- If you have cleared the reader controller PCB's RAM or replaced the reader controller PCB, enter the value on the service label.

Adjustment method

Adjustment range 120 to 150 (Value at time of factory shipment: Factory-adjusted value)
(Value after RAM clear: 150)

Caution

When adjusting the optical shading measurement position, use the following mode:

- COPIER>FUNCTION>CCD>SH-PS-ST

<CCD>

Used to make CCD-related adjustments.

W-PLT-X/Y/Z

Used to enter white level data for standard white plate.

- Adjustment method**
- If you have cleared the reader controller PCB's RAM or replaced the reader controller PCB, enter the values on the service label.
 - If you have replaced the platen glass, enter the values on the platen glass (see figure below).

Adjustment range **0 to 10000 (Values at time of factory shipment: Factory-measured values)**
(Values after RAM clear: W-PLT-X = 8271
W-PLT-Y = 8725
W-PLT-Z = 9418)

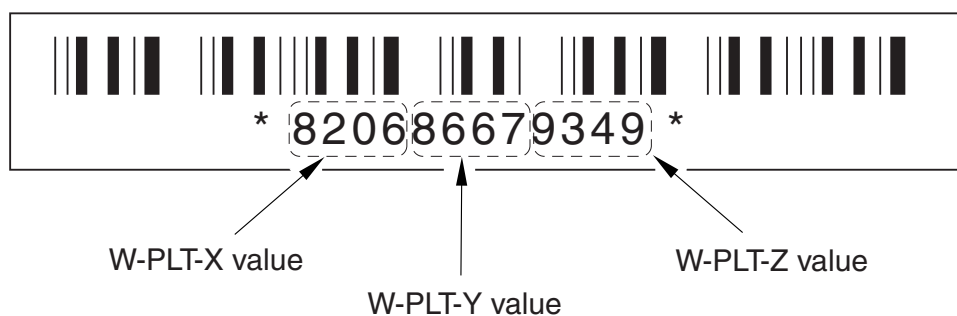

F05-501-04

CCDU-RG/GB

Used to enter color shift compensation value in sub-scanning direction (between R and G/G and B for document reading dependent on CCD unit + lens).

- Adjustment method**
- If you have cleared the reader controller PCB's RAM or replaced the reader controller PCB, enter the value on the service label.
 - If you have replaced the CCD unit, enter the value on the label attached to the CCD unit (also enter this value on the service label).

Adjustment range **-1000 to 1000 (Value at time of factory shipment: Factory-measured value)**
(Value after RAM clear: 0)

COPIER>ADJUST

- Note Of the color shift in the sub-scanning direction generated by the read optics, the amount dependent on the CCD unit + lens is compensated by adjusting the 3-line CCD sensor's compensation amount between R and G. Image compensation is performed by image processing by the main controller PCB.
-

CL-R-RG/GB

Used to enter the color shift compensation value (during normal reading in color mode) in the sub-scanning direction.

- Adjustment method • If you have cleared the reader controller PCB's RAM or replaced the reader controller PCB, enter the value on the service label.

Adjustment range **-1000 to 1000 (Value at time of factory shipment: Factory-measured value)**
(Value after RAM clear: 0)

- Note During normal reading in color mode, the color shift in the sub-scanning direction due entirely to the reader unit is compensated by adjusting the 3-line CCD sensor's compensation amount between R and G/G and B. Image compensation is performed by image processing by the main controller PCB.
-

BW-R-RG/GB

Used to enter the color shift compensation value (during normal reading in black and white mode) in the sub-scanning direction.

- Adjustment method • If you have cleared the reader controller PCB's RAM or replaced the reader controller PCB, enter the value on the service label.

Adjustment range **-1000 to 1000 (Value at time of factory shipment: Factory-measured value)**
(Value after RAM clear: 0)

- Note During normal reading in black and white mode, the color shift in the sub-scanning direction due entirely to the reader unit is compensated by adjusting the 3-line CCD sensor's compensation amount between R and G/G and B. Image compensation is performed by image processing by the main controller PCB.

CLF-R-RG/GB

- Used to enter the color shift compensation value (during high-speed reading in color mode) in the sub-scanning direction.
- Adjustment method • If you have cleared the reader controller PCB's RAM or replaced the reader controller PCB, enter the value on the service label.
- Adjustment range** **-1000 to 1000 (Value at time of factory shipment: Factory-measured value)**
(Value after RAM clear: 0)
- Note During high-speed reading in color mode, the color shift in the sub-scanning direction due entirely to the reader unit is compensated by adjusting the 3-line CCD sensor's compensation amount between R and G/G and B. Image compensation is performed by image processing by the main controller PCB.
-

FCCDU-RG/GB

- Used to enter the color shift compensation value (between R and G/G and B for document reading dependent on CCD unit + lens at time of factory shipment) in the sub-scanning direction.
- Adjustment method • If you have cleared the reader controller PCB's RAM or replaced the reader controller PCB, enter the value on the service label.
- Adjustment range** **-1000 to 1000 (Value at time of factory shipment: Factory-measured value)**
(Value after RAM clear: 0)
- Note Of the color shift in the sub-scanning direction generated by the read optics, the amount dependent on the CCD unit + lens is compensated by adjusting the 3-line CCD sensor's compensation amount between G and B. Image compensation is performed by image processing by the main controller PCB.

COPIER>ADJUST

<LASER>

Used to make laser-related adjustments.

PVE-OFST

Used to enter the adjusted value of the laser irradiation position.

Adjustment method • If you have cleared the DC controller PCB's RAM or replaced the DC controller PCB, enter the value on the service label.

Adjustment range **-25 to 25 (Value at time of factory shipment: Factory-measured value) (Value after RAM clear: 0)**

Note This item is to enable input of the factory-adjusted value, and should not be adjusted in the market.

<IMG-REG>

Used to adjust image position.

MAG-H-K

Used to adjust magnification of the Bk image's main scanning direction.

Adjustment method • If you have cleared the DC controller PCB's RAM or replaced the DC controller PCB, enter the value on the service label.

Adjustment range **-10 to 10 (Value at time of factory shipment/value after RAM clear: 0)**

Note This item is to enable input of the factory-adjusted value, and should not be adjusted in the market.

<BLANK>

Used to adjust image blank width.

BLANK-T

Used to enter adjusted value of image blank width (leading edge).

Adjustment method • If you have cleared the main controller PCB's RAM or replaced the SRAM PCB, enter the value on the service label.

Adjustment range 0 to 1000 (Value at time of factory shipment/value after RAM clear: +59)

BLANK-L

Used to enter adjusted value of image blank width (left edge).

Adjustment method • If you have cleared the main controller PCB's RAM or replaced the SRAM PCB, enter the value on the service label.

Adjustment range 0 to 1000 (Value at time of factory shipment/value after RAM clear: +47)

BLANK-R

Used to enter adjusted value of image blank width (right edge).

Adjustment method • If you have cleared the main controller PCB's RAM or replaced the SRAM PCB, enter the value on the service label.

Adjustment range 0 to 1000 (Value at time of factory shipment/value after RAM clear: +47)

BLANK-B

Used to enter adjusted value of image blank width (trailing edge).

Adjustment method • If you have cleared the main controller PCB's RAM or replaced the SRAM PCB, enter the value on the service label.

Adjustment range 0 to 1000 (Value at time of factory shipment/value after RAM clear: +59)

COPIER>ADJUST

<PASCAL>

Used to adjust the test print read density.

OFST-P-Y/M/C/K

Performs offset adjustment on the test print read signal for PASCAL control during automatic gradation compensation (full compensation).

Adjustment method • Increasing the value makes the image after automatic gradation compensation (full compensation) denser.

Adjustment range **-128 to +128 (Value at time of factory shipment/value after RAM clear: 0)**

<FEED-ADJ>

REGIST

Used to adjust the registration roller clutch ON timing.

Adjustment method • Increasing the value by 1 moves the image by 0.1 mm in the direction of the leading edge of the paper.
• If you have cleared the DC controller PCB's RAM or replaced the DC controller PCB, enter the value on the service label.

Adjustment range **-50 to 50 (0.1 mm units)**
(Value at time of factory shipment: Factory-adjusted value)
(Value after RAM clear: -20)

ADJ-REFE

Used to adjust the horizontal registration during re-feed.

Adjustment method • Increasing the value by 1 moves the image 0.1 mm away from you.
• If you have cleared the DC controller PCB's RAM or replaced the DC controller PCB, enter the value on the service label.

Adjustment range **-100 to 100 (0.1 mm units)**
(Value at time of factory shipment: Factory-adjusted value)
(Value after RAM clear: 0)

<CST-ADJ>

MF-A4R

- Used to enter the basic value for the manual feed tray's paper width (A4R).
- Adjustment method**
- If you have cleared the DC controller PCB's RAM or replaced the DC controller PCB, enter the value on the service label.
 - When replacing the paper width detection VR or registering a new value, execute the following service mode: FUNCTION>CST.
- Adjustment range** **0 to 255**
(Value at time of factory shipment: Factory-adjusted value)
(Value after RAM clear: 141)
-

MF-A6R

- Used to enter the basic value for the manual feed tray's paper width (A6R).
- Adjustment method**
- If you have cleared the DC controller PCB's RAM or replaced the DC controller PCB, enter the value on the service label.
 - When replacing the paper width detection VR or registering a new value, execute the following service mode: FUNCTION>CST.
- Adjustment range** **0 to 255**
(Value at time of factory shipment: Factory-adjusted value)
(Value after RAM clear: 235)
-

MF-A4

- Used to enter the basic value for the manual feed tray's paper width (A4).
- Adjustment method**
- If you have cleared the DC controller PCB's RAM or replaced the DC controller PCB, enter the value on the service label.
 - When replacing the paper width detection VR or registering a new value, execute the following service mode: FUNCTION>CST.
- Adjustment range** **0 to 255**
(Value at time of factory shipment: Factory-adjusted value)
(Value after RAM clear: 26)

COPIER>ADJUST

<MISC>

Used to make other adjustments.

SEG-ADJ

Used to adjust the text and photo separation level for text/photo/map mode.

- Adjustment method
- To make documents more easily recognized as photo documents, increase the setting value.
 - To make documents more easily recognized as text documents, decrease the setting value.

Adjustment range -4 to 4 (Value at time of factory shipment/value after RAM clear: 0)

K-ADJ

Used to adjust the black recognition level during black text processing.

- Adjustment method
- To make text more easily recognized as black, increase the setting value.

Adjustment range -3 to 3 (Value at time of factory shipment/value after RAM clear: 0)

ACS-ADJ

Used to adjust the color recognition level during ACS mode.

- Adjustment method
- To make documents more easily recognized as black and white documents, increase the setting value.
 - To make documents more easily recognized as color documents, decrease the setting value.

Adjustment range -3 to 3 (Value at time of factory shipment/value after RAM clear: 0)

5.2 FEEDER

The FEEDER>ADJUST items are described below.

DOCST

Used to adjust the document stop position during ADF paper feed (document tray paper feed).

Note

- Increasing the value makes the leading edge blank smaller.

Adjustment range -100 to 100 (0.337 mm units)

Caution

Delivering the document makes the setting value valid, so be sure to press the OK key to deliver the document.

Operation method

- 1) Place the document on the ADF document tray.
- 2) Select the item, use the numeric keypad to change the setting value, then press the OK key to set it.
- 3) Press the OK key again to deliver the document and stop it (aligned left) on the platen glass.
- 4) Open the ADF carefully, and check the stop position of the document.
Standard: Stop position $L4 = 0 \pm 1$ mm
L4: Distance from vertical size plate edge to document edge

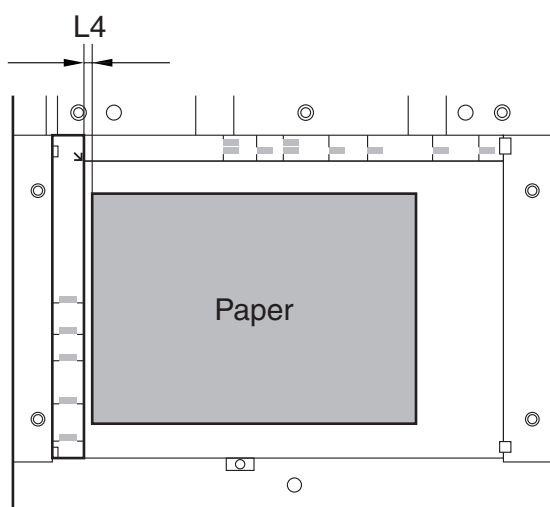

F05-502-01

FEEDER>ADJUST

- If the document is farther left than the arrow in the figure below:
Increase the value (the leading edge blank is made smaller).

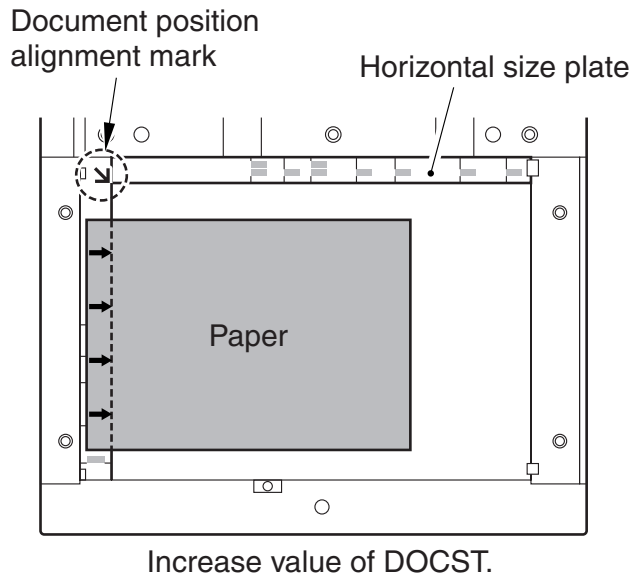

F05-502-02

- If the document is farther right than the arrow in the figure below:
Decrease the value (the leading edge blank is made larger).

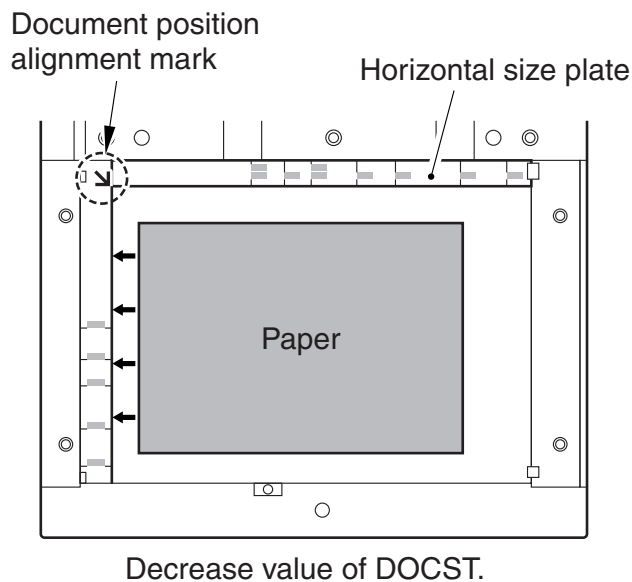

F05-502-03

- 5) Carefully close the ADF and press the OK button to deliver the document to the document tray.

DOCST-R

Used to adjust the document stop position during two-sided paper feed (document's second side).

Adjustment range -100 to 100 (0.337 mm units)

Caution Delivering the document makes the setting value valid, so be sure to press the OK key to deliver the document.

Operation method

- 1) Place the document on the ADF document tray.
- 2) Select the item, use the numeric keypad to change the setting value, then press the OK key to set it.
- 3) Press the OK key again to deliver the document and stop it (aligned right) on the platen glass.
- 4) Open the ADF carefully, and check the stop position of the document.
Standard: Stop position L5 = 12.0 ± 1.5 mm
L5: Distance from glass edge to document edge

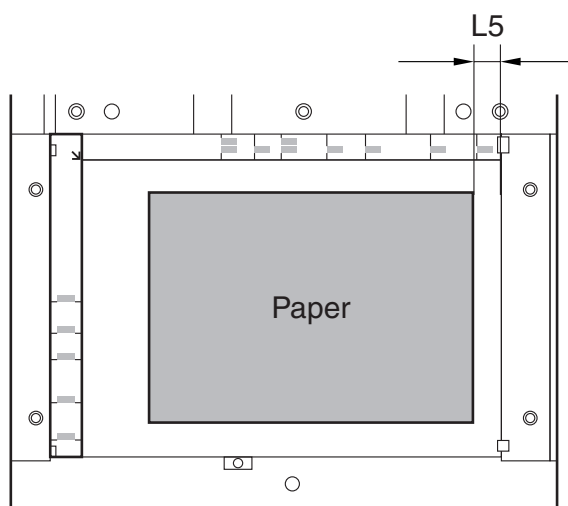

F05-502-04

FEEDER>ADJUST

- If the document is farther left than the arrow in the figure below:
Decrease the value (the leading edge blank is made larger).

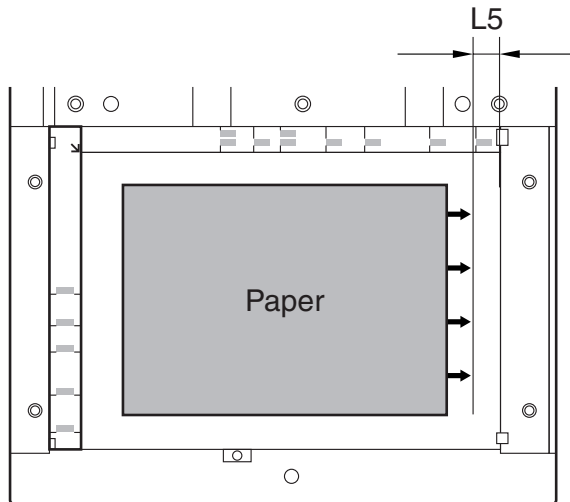

Decrease value of DOCST.

F05-502-05

- If the document is farther right than the arrow in the figure below:
Increase the value (the leading edge blank is made smaller).

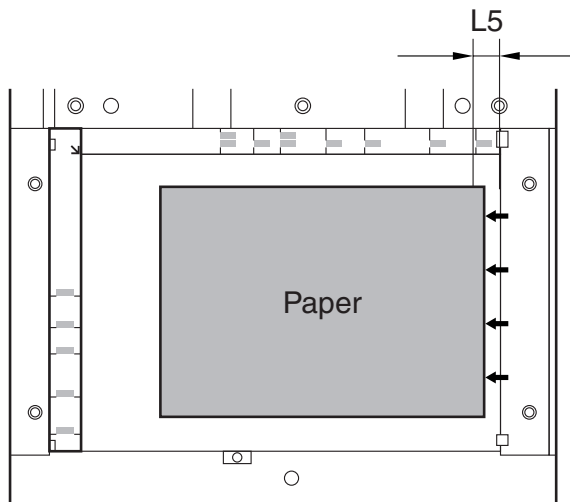

Increase value of DOCST.

F05-502-06

- 5) Carefully close the ADF and press the OK button to deliver the document to the document tray.

6 ADJUST (adjustment mode): Level 2

The COPIER>ADJUST (Level 2) screen is shown below.

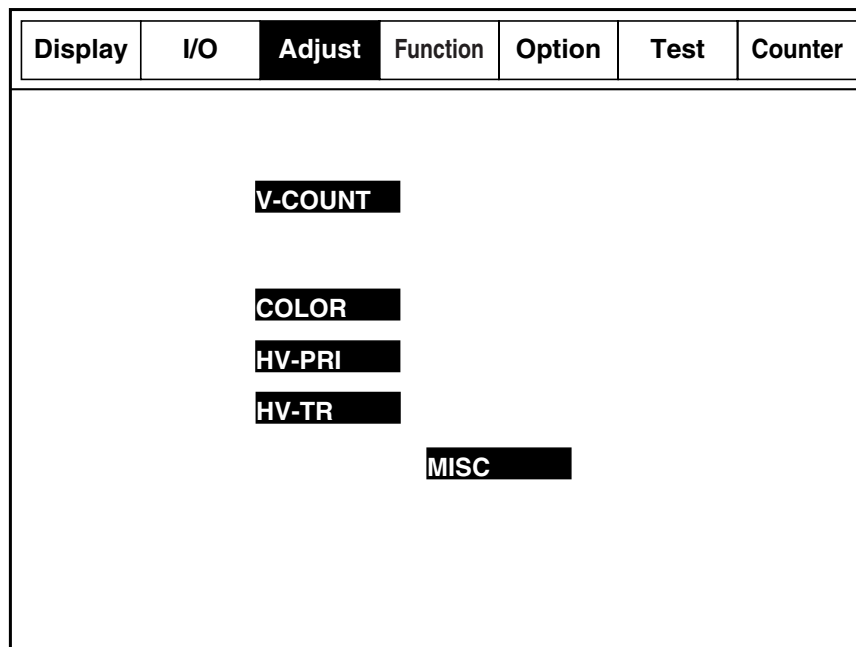

F05-600-01

<V-COUNT>

- VCONT-Y/M/C/K (Used to adjust electric potential for image contrast.)
Adjustment range: -30 to 30 (10 V units) (Value at time of factory shipment/value after RAM clear: 0)
The larger the setting value, the higher the density.
Whenever possible, avoid using this setting during normal operation.
- VBACK-Y/M/C/K (Used to adjust electric potential for removing image fog.)
Adjustment range: Y/M -6 to 12 (5 V units) (Value at time of factory shipment/value after RAM clear: 0)
C/K -12 to 6 (5 V units) (Value at time of factory shipment/value after RAM clear: 0)
The larger the setting value, the more fog is reduced.
Whenever possible, avoid using this setting during normal operation.

<COLOR>

- LD-OFS-Y/M/C/K (Used to adjust low-density color balance.)
Whenever possible, avoid using this setting during normal operation.
- MD-OFS-Y/M/C/K (Used to adjust medium-density color balance.)
Whenever possible, avoid using this setting during normal operation. (Recommended setting value: -1)

COPIER>ADJUST

- HD-OFS-Y/M/C/K (Used to adjust high-density color balance.)
Whenever possible, avoid using this setting during normal operation. (Recommended setting value: -2)

<HV-PRI>

- USUB-Y/M/C/KAC (Used to adjust upstream auxiliary brush charge voltage.)
Whenever possible, avoid using this setting during normal operation.
- DIS-TGY/M/C/K (Used to adjust the offset to the target current used in discharge current control (normal paper).)
Whenever possible, avoid using this setting during normal operation.
- DIS-TGY2/M2/C2/K2 (Used to adjust the offset to the target current used in discharge current control (card/special paper/transparencies).)
Whenever possible, avoid using this setting during normal operation.

<HV-TR>

The adjusted offset doesn't become valid unless all of the following 6 items are entered: 2TR-TGT, 2TR-SHR, TR-PPR, TR-ENV, TR-CLR and TR-DUP. The settings entered for all 6 items make up a single pattern. 8 patterns can be stored in memory.

- 2TR-TGT1/2/3/4/5/6/7/8 (Used to adjust the offset to the secondary transfer target current.)
Adjustment range: -5 to +5 (2 μ A units) (Value at time of factory shipment/value after RAM clear: 0)
Increasing the setting value: Effective for images with toner spatter/water droplets.
Decreasing the setting value: Effective for images with white marks, white blotches, rough-textured half-tones.
- 2TR-SHR1/2/3/4/5/6/7/8 (Used to adjust the offset to the secondary transfer paper-portion voltage.)
Adjustment range: -5 to +5 (100 V units) (Value at time of factory shipment/value after RAM clear: 0)
Increasing the setting value: Effective for images with toner spatter/water droplets.
Decreasing the setting value: Effective for images with white marks, white blotches, rough-textured half-tones.
- TR-PPR1/2/3/4/5/6/7/8 (paper type item for secondary transfer offset adjustment)
 - 1: Normal paper (Value at time of factory shipment/value after RAM clear: 1)
 - 2: Recycled paper
 - 3: Bond paper
 - 4: Mother print
 - 5: Card

- 6: Extra thick card
- 7: Special paper 1 (including labels)
- 8: Glossy paper
- 9: Special paper 2 (including Japanese paper)
- 10: Postcards/envelopes
- 11: Transparencies (color)
- 12: Transparencies (monochrome)
- TR-PPR1/2/3/4/5/6/7/8 (environmental item for secondary transfer offset adjustment)
Enter value of COPIER>DISPLAY>MISC>ENV-TR.
 - 1: Low-humidity environment (Value at time of factory shipment/value after RAM clear: 1)
 - 2: Normal-humidity environment
 - 3: High-humidity environment
- TR-PPR1/2/3/4/5/6/7/8 (color mode item for secondary transfer offset adjustment)
 - 1: Full-color mode (Value at time of factory shipment/value after RAM clear: 1)
 - 2: Monochrome mode
- TR-PPR1/2/3/4/5/6/7/8 (one/two-sided item for secondary transfer offset adjustment)
 - 1: One-sided (Value at time of factory shipment/value after RAM clear: 1)
 - 2: Automatic two-sided
 - 3: Manual feed two-sided

<MISC>

- ACS-EN (Used to adjust ACS recognition zone.)
Increasing the setting value expands the recognition zone.
- ACS-CNT (Used to adjust color recognition pixel count zone during ACS recognition.)
Increasing the setting value expands the recognition zone.
- ACS-DF (Used to adjust ACS recognition zone during DF use.)
Increasing the setting value expands the recognition zone.

COPIER>FUNCTION

7 FUNCTION (operation/inspection mode): Level 1

7.1 COPIER

The COPIER>FUNCTION (Level 1) screen is shown below.

Display	I/O	Adjust	Function	Option	Test	Counter
			INSTALL	FIXING	SYSTEM	
			CCD	PANEL		
			LASER	PART-CHK		
				CLEAR		
				MISC-R		
				MISC-P		
			CST			
			CLEANING			

F05-701-01

The top right of the screen displays the copier's mechanical status. Pay attention to this display when executing service modes. The main statuses displayed when executing this mode are:

<READY>	Ready for performing service/copy operation.
<SERVICE>	Executing service mode. This display appears when inspecting operations in a service mode.
<DOOR>	Cover open
<WAITING>	Waiting
<NO-PAPER>	No paper
<COPYING>	Copying
<ERROR>	Error
<NO-TONER>	No toner
<WTNR-FUL>	Waste toner full
<ALARM>	Alarm

<INSTALL>

Used to perform installation operations.

CARD

Used to make card reader installation settings.

Setting values **1 to 2001 (Value at time of factory shipment/value after RAM clear: 1)**

Operation method Enter the number of cards to use. (You can use up to 1,000 cards from the entered number.)

Initialize the card management information.

- Initialize the card name (department ID) (from the entered number).
 - Initialize the card's password.
-

DRY-RT

Eliminates condensation during installation.

Note This item is used to eliminate condensation generated in the copier immediately after installation. When the copier has detected that the drum units and toner containers are out, the ITB is forced to idle to raise the temperature at points of condensation with fixing temperature regulation left ON, evaporating the moisture.

Operation method

- 1) Turn the main power switch OFF, and remove the drum unit and toner container for each color.
- 2) Replace the transfer cleaning unit with a dummy transfer cleaning unit (since the cleaning plate may be damaged otherwise).
- 3) Turn the main power switch ON.
- 4) Select this item, and press the OK key.
- 5) Wait for the operation to stop automatically. (The operation may take between 6 and 180 minutes depending on the environment.)
- 6) 'OK' is displayed when the operation completes normally.
- 7) Insert the drum units, toner containers and transfer cleaning unit, and check the image with half-tones.

KEY

Used to set management key function recognition.

Setting values **0: Don't recognize management key function (value at time of factory shipment).**

1: Recognize management key function.

Operation method

- 1) Select COPIER > INSTALL > KEY, then enter "1".
- 2) Turn the main power switch OFF/ON (the management key function is now recognized).

COPIER>FUNCTION

<CCD>

Used for automatic adjustment of CCD-related items.

CCD-ADJ

Adjusts gain of analog processor unit (in CCD PCB).

Operation
method

- 1) Select this item.
 - 2) Press the OK key.
- The operation starts. When the operation finishes, it stops automatically.



Memo

When you turn the main power switch ON, the same automatic adjustment operation done by this item is performed.

SH-PS-ST

Automatically adjusts optimum position on standard white plate used for shading compensation.

Caution

- If the standard white plate on the underside of the platen glass is dirty, it can't be adjusted correctly. Always clean the white plate first.
- Perform this operation if you have replaced the platen glass (standard white plate) or noticeable white lines appear in half-tone areas.

Operation
method

- 1) Clean the underside of the platen glass.
- 2) Select <SH-PS-ST> to display the item in reverse, then press the OK key.
- 3) Automatic adjustment executes (takes between 5 and 180 seconds).
- 4) After adjustment, the operation stops automatically and the result (OK or NG) is displayed.
 - If NG is displayed, check the items below, and redo adjustment.
 - a. Is the platen glass attached normally?
 - b. Is the standard white plate attached to the platen glass a correct type?
 - c. Is the document illumination lamp lit?
- 5) The COPIER > ADJUST > ADJ-XY > ADJ-S service mode item is updated, so enter the new value on the service label.

<LASER>

Used for laser-related automatic adjustment.

L-ADJ-O

- Automatically adjusts laser emission quantity.
- Operation method
- Execute this item in the following cases:
- If a laser unit was replaced (if the Y, M, C or K unit was replaced or if multiple units were replaced simultaneously)
 - If the DC controller PCB was replaced
 - If the DC controller PCB's RAM was cleared
- 1) Remove all 4 color drum units, and close the front cover.
 - 2) Select this item, and press the OK key to execute the operation. The operation stops automatically.
 - 3) When automatic adjustment has finished, 'END' is displayed in the screen.
- Note
- The DC controller uses the photo diode in the laser unit to automatically measure the light quantity when each laser emits its minimum light quantity. This operation is used to compensate the time the laser lights during minimum light quantity emission.
- Each laser unit (Y/M/C/K) is adjusted in sequence.

<CST>

Automatically adjusts cassette/manual feed tray.

MF-A4R, MF-A6R, MF-A4

- Registers basic value of manual feeder's (DADF's) paper width.
A4R width: 210mm, A6R width: 105mm, A4 width: 297mm
- Once registered, the basic value can be fine-tuned by executing
COPIER> ADJUST > CST-ADJ > MF-A4R, MF-A6R or MF-A4.
- Operation method
- 1) Place A4R size paper in the manual feeder, and set the size guide to the A4R width.
 - 2) In this service mode, select 'MF-A4R' to display the item in reverse. Press the OK key to perform automatic adjustment and register the value.
 - 3) Repeat Steps 1) and 2) to register the basic values for the A6R and A4 sizes.

COPIER>FUNCTION

<CLEANING>

Used to execute cleaning operations.

TBLT-CLN

Cleans intermediate transfer belt.

Image imperfections are improved by removing impurities adhering to the intermediate transfer belt (such as fingerprints, grease and paper dust).

Operation
method

- 1) Press "TBLT-CLN" to display the item in reverse and select it.
- 2) Press the OK key.

The cleaning operation lasts about 80 seconds, then ends automatically.

FDRL-CLN

Used when cleaning face-down paper delivery roller 1/2.

Operation
method

- 1) Select this item, then press the OK key to start the rollers operating.
 - 2) While both rollers are operating, press against each with a cloth soaked in alcohol to clean it.
 - 3) Press the stop key to stop the rollers.
-

RVRL-CLN

Used when cleaning reverse roller.

Operation
method

- 1) Open the paper delivery cover.
 - 2) Select this item and press the OK key to start the roller operating.
 - 3) While the roller is operating, press against it with a cloth soaked in alcohol to clean it.
 - 4) Press the stop key to stop the roller.
-

DEVL-CLN

Cleans inside developer unit.

Image imperfections are improved by forcibly consuming toner that has been over-agitated (toner with improper charge) by the toner agitation screw.

Operation
method

- 1) Select this item and press the OK key.
- 2) The cleaning operation lasts about 160 seconds, then ends automatically.

<FIXING>

Automatically adjusts fixing unit.

NIP-CHK

Fixing nip width automatic measurement output.

Operation
method

- 1) If the finisher is connected, remove it from the copier and pull out the lattice cable.
- 2) Place A4 (LTR) size paper in the manual feed tray.
- 3) Press the OK key (the paper in the manual feed tray is fed).
- 4) When the fed paper is pressed by the fixing roller, it stops, and is delivered about 15 seconds later.
- 5) Check that the nip width of the delivered paper is the standard value.

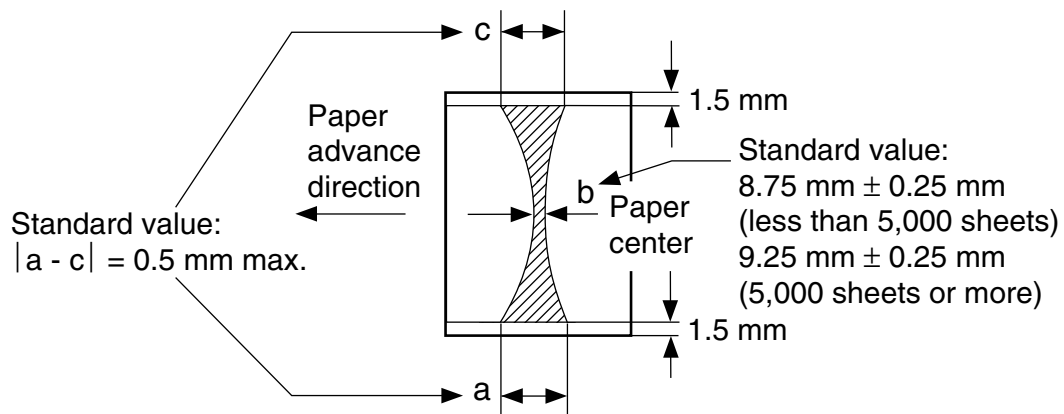

F05-701-02

- 6) If the standard value isn't met, adjust the value. See the Printer Manual, Chapter 6, 'Fixing System', 4. 'Disassembly and assembly'; 4.2 'After fixing unit disassembly'.
- 7) After completing the operation, output a test print (COPIER>TEST>PG>TYPE (6): Grid).

Remark

The paper is delivered from the side paper delivery tray.

COPIER>FUNCTION

<PANEL>

Used to inspect operation panel's operation.

LCD-CHK

Used to check missing dots in LCD.

- Operation method
- 1) Select this item, then press the OK key to start the operation.
The touch panel's front surface should light repeatedly in the sequence: white, black, red, green and blue. (Check that it does.)
 - 2) Press the stop key (the clear key on printer models) to end the operation.

LED-CHK

Used to check that operation panel's LEDs light.

- Operation method
- 1) Select this item, then press the OK key to start the operation.
The LEDs light sequentially.
 - 2) Press LED-OFF to end the operation.

LED-OFF

Used in checking that operation panel's LEDs light.

- Operation method
- 1) Selecting this item stops the LED-CHK operation.

KEY-CHK

Used to check key input.

- Operation method
- 1) Select "KEY-CHK" to display the number/name of the entered key.
 - 2) Press the key to check. If the key is normal, the text for it appears in the touch panel (see separate table).
 - 3) Select "KEY-CHK" again to exit the key input check operation.

Input key numbers, names

Key	Screen display
0 to 9, #, *	0 to 9, #, *
Reset	RESET
Stop	STOP
User mode	USER
Start	START
Power save	STAND BY
Clear	CLEAR
Secret code	ID
Help	?
Counter check	BILL

T05-701-01

TOUCHCHK

- Used to adjust coordinate positions of analog touch panel.
- Operation method
- Used to align the touch panel touch position with the LCD coordinate position.
 - Execute this service mode item if you have replaced the LCD unit.
- 1) Select "TOUCHCHK" to display the item in reverse, then press the OK key.
 - 2) "✚" appears on the touch panel at 9 positions sequentially. After you press each position, adjustment is complete.

<PART-CHK>

CL

- Used to specify clutch for operation check.
(Range: 1 to 10, 5 and above are reserved.)
- Operation method
- 1) Select this item.
 - 2) Enter the desired clutch code on the numeric keypad.

1: Two-sided registration clutch	CL1
2: Two-sided paper feed clutch	CL2
3: Conveyor clutch	CL1 (paper deck)
4: Paper feed clutch	CL2 (paper deck)
 - 3) Press the OK key.
 - 4) Press CL-ON, and check the operation.

CL-ON

- Used to start clutch operation check.
- Operation method
- 1) Select this item, and press the OK key. The clutch turns ON/OFF in the pattern below.
0.5 second ON → 10 seconds OFF → 0.5 second ON →
10 seconds OFF → 0.5 second ON → OFF

FAN

- Used to specify fan for operation check.
(Range: 1 to 10; 7 and above are reserved.)
- Operation method
- 1) Select this item.
 - 2) Enter the desired fan code on the numeric keypad.

1: Power cooling fan	FM1
2: Fixing exhaust heat fan	FM2
3: Copier exhaust heat fan	FM3
4: Cleaner fan	FM4
5: Paper delivery cooling fan	FM5
6: Manual feed cooling fan	FM6
 - 3) Press the OK key.
 - 4) Press FAN-ON, and check the operation.

COPIER>FUNCTION

FAN-ON

Starts fan operation.

Operation for power fan, fixing fan and cleaner fan:

- 1) Select this item, and press the OK key. The fan performs the operation below.

10 seconds ON at full-speed → 10 seconds ON at half-speed → Standby

Operation for copier exhaust heat fan, paper delivery cooling fan and manual feed cooling fan:

- 1) Select this item, and press the OK key. The fan performs the operation below.

10 seconds ON at full-speed → Standby

Operation for controller fan:

- 1) Select this item, and press the OK key. The fan performs the operation below.

MTR

Used to specify motor for operation check.

(Range: 1 to 25; 18 and above are reserved.)

Operation
method

- 1) Select this item.
- 2) Enter the desired motor code on the numeric keypad.

1: Drum ITB motor	M1
2: Toner container motor (Y)	M20
3: Toner container motor (M)	M21
4: Toner container motor (C)	M22
5: Toner container motor (Bk)	M23
6: Cassette 1 paper feed motor	M6
7: Cassette 2 paper feed motor	M7
8: Cassette 3 paper feed motor	M51
9: Cassette 4 paper feed motor	M52
10: Paper deck main motor	M1D (paper deck)
11: Registration front motor	M8
12: Registration motor	M9
13: Paper delivery vertical path motor	M10
14: Face-down paper delivery motor	M11
15: Fixing motor	M24
16: Horizontal registration motor	M25
17: Two-sided transfer motor	M26
- 3) Press the OK key.
- 4) Press MTR-ON, and check the operation.

MTR-ON

- Starts motor operation.
- Operation method Toner container motors (Y/M/C/K):
- 1) Remove the toner container, and leave the front cover open and push the front cover detect sensor with cover switch tool.
 - 2) Select this item, and press the OK key.
 - 10 seconds ON → OFF
- Horizontal resist motor:
- 1) Select this item, and press the OK key.
 - HP search operation starts → Stops automatically when complete
- Motors other than toner container motors (Y/M/C/K) or horizontal resist motor:
- 1) Select this item, and press the OK key.
 - 10 seconds ON → OFF
-

SL

- Used to specify solenoid for operation check.
(Range: 1 to 15; 10 and above are reserved.)
- Operation method 1) Select this item.
- 2) Enter the desired solenoid code on the numeric keypad.

1: Manual paper feed solenoid	SL1
2: Paper delivery path switching solenoid 1	SL2
3: Cassette 1 paper feed solenoid	SL3
4: Cassette 2 paper feed solenoid	SL4
5: Cassette 3 paper feed solenoid	SL51
6: Cassette 4 paper feed solenoid	SL52
7: Paper delivery path switching solenoid 2	SL5
8: Paper deck paper feed solenoid	SL1D
9: Paper container OPEN solenoid	SL2D
 - 3) Press the OK key.
 - 4) Press SL-ON, and check the operation.
-

SL-ON

- Starts solenoid operation.
- Operation method 1) Select this item, and press the OK key. The solenoid turns ON/OFF in the pattern below.
- 0.5 second ON → 10 seconds OFF → 0.5 second ON →
10 seconds OFF → 0.5 second ON → OFF

COPIER>FUNCTION

<CLEAR>

Used to clear RAM, error codes, jam history or error code history.

ERR

Clears error codes.
(Cleared error codes: E000, E001, E002, E003)

- Operation method
- 1) Select this item, and press the OK key.
 - 2) Turn the main power OFF/ON.
-

DC-CON

Clears DC controller PCB's RAM.

- Caution The RAM is cleared after the main power switch is turned OFF/ON.
- Operation method
- 1) Select COPIER > FUNCTION > MISC-P > P-PRINT to print out the service mode setting values.
 - 2) Select this item, then press the OK key.
 - 3) Turn the main power OFF/ON.
 - 4) Enter the data printed by the P-PRINT operation as needed.
-

R-CON

Clears reader controller PCB's RAM.

- Caution The RAM is cleared after the main power switch is turned OFF/ON.
- Operation method
- 1) Select COPIER > FUNCTION > MISC-P > P-PRINT to print out the service mode setting values.
 - 2) Select this item, then press the OK key.
 - 3) Turn the main power OFF/ON.
 - 4) Enter the data printed by the P-PRINT operation as needed.
-

JAM-HIST

Clears jam history.

- Caution The jam history is cleared after the main power switch is turned OFF/ON.
- Operation method
- 1) Select this item, then press the OK key.
 - 2) Turn the main power OFF/ON.
-

ERR-HIST

Clears error code history.

- Caution The error code history is cleared after the main power switch is turned OFF/ON.
- Operation method
- 1) Select this item, then press the OK key.
 - 2) Turn the main power OFF/ON.

PWD-CLR

- Clears ‘system administrator’ password set in user mode.
- Caution** The password value is cleared after the main power switch is turned OFF/ON.
- Operation method**
- 1) Select this item, then press the OK key.
 - 2) Turn the main power OFF/ON.
-

ADRS-BK

- Clears address book data.
- Caution** The address book data is cleared after the main power switch is turned OFF/ON.
- Operation method**
- 1) Select this item, then press the OK key.
 - 2) Turn the main power OFF/ON.
-

CNT-MCON

- Clears service counters maintained by main controller PCB (main). (See the COUNTER mode items for the counters cleared.)
- Caution** The counter values are cleared after the main power switch is turned OFF/ON.
- Operation method**
- 1) Select this item, then press the OK key.
 - 2) Turn the main power OFF/ON.
-

CNT-DCON

- Clears following service counters maintained by DC controller PCB:
- COPIER > COUNTER > DRBL-2 > SORT
 - COPIER > COUNTER > DRBL-2 > FIN-STPR
 - COPIER > COUNTER > DRBL-2 > FIN-PDDL
 - COPIER > COUNTER > DRBL-2 > SADDLE
 - COPIER > COUNTER > DRBL-2 > SDL-STPL
- Caution** The counter values are cleared after the main power switch is turned OFF/ON.
- Operation method**
- 1) Select this item, then press the OK key.
 - 2) Turn the main power OFF/ON.
-

OPTION

- Restores OPTION service mode setting values to default values (RAM clear values).
- Caution** The setting values are cleared after the main power switch is turned OFF/ON.
- Note** The cleared data is the data in the main controller, DC controller and reader controller.
- Operation method**
- 1) Select COPIER > FUNCTION > MISC-P > P-PRINT to print out the service mode setting values.
 - 2) Select this item, then press the OK key.
 - 3) Turn the main power OFF/ON.
-

COPIER>FUNCTION

MMI

Clears following user mode setting values:

- Backup data for copy operation panel (user-set values)
- Common settings backup data (user-set values)
- Backup data (except fax data) (user-set values)

Caution The setting values are cleared after the main power switch is turned OFF/ON.

Operation method

- 1) Select this item, then press the OK key.
- 2) Turn the main power OFF/ON.

MN-CON

Clears RAM on main controller PCB's SRAM board.

Caution

- The RAM is cleared after the OK key is pressed.
- Executing this item initializes all the data on the SRAM board. In other words, file management information for the hard disk is initialized, and image data on the hard disk can no longer be read. Before executing this item, explain to the user that all images in the BOX will be lost, and receive permission to execute.

Operation method

- 1) Select COPIER > FUNCTION > MISC-P > P-PRINT to print out the service mode setting values.
- 2) Select this item, then press the OK key.

CARD

Clears card ID (department) data.

Caution The card ID data is cleared after the main power switch is turned OFF/ON.

Operation method

- 1) Select this item, then press the OK key.
- 2) Turn the main power OFF/ON.

<MISC-R>

Used to check operation of reader unit.

SCANLAMP

Executes document illumination lamp lighting operation.

Operation method

- 1) Select this item.
- 2) Press the OK key. The document illumination lamp lights for 3 seconds.

<MISC-P>

Used to check operation of printer unit.

P-PRINT

	Prints service mode setting values.
Operation method	1) Select this item. 2) Press the OK key to print the setting values.
Note	Printing takes about 15 seconds to start.

USER-PRT

	Prints user mode list.
Operation method	1) Select this item. 2) Press the OK key to print the list.
Note	Printing takes about 3 seconds to start.

LBL-PRNT

	Prints service label.
Operation method	1) Place A4/LTR paper in the manual feed tray. 2) Select this item. 3) Press the OK key to print the label.
Note	Printing takes about 15 seconds to start.

<SYSTEM>

Used to check system operation.

DOWNLOAD

	Switches to download mode.
Operation method	1) Select this item. 2) Press OK to enter download mode and have the copier wait for commands (wait for connection). ("STNDBY" is now displayed, next to the DOWNLOAD sub-items.) 3) Use the service support tool to start downloading. ("CONNECTED" is displayed during communication with the PC.) 4) When communication ends, "HOLD" is displayed. (The power can be turned off when "HOLD" is displayed.)

COPIER>FUNCTION

CHK-TYPE

Used to specify partition number when executing HD-CHECK or HD-CLEAR.

<Operation method>

- 1) Select this item.
- 2) Use the numeric keypad to select the desired partition number.
 - 0: Check and restore all bad sectors on hard disk
 - 1: Image storage area
 - 2: General-purpose file storage area
 - 3: PDL file storage area
 - 4: Firmware storage area
 - General-purpose files include user-set data, log data, PDL spool data, and management information for image data.
- 3) Press the OK key.

HD-CHECK

Performs partition check and restoration process specified by CHK-TYPE item.

- Operation method
- 1) Select this item.
 - 2) Press the OK key.
 - 3) The result is displayed (1: OK, 2: NG (hardware), 3: NG (software), restored sectors/substitute sectors).

HD-CLEAR

Initializes partition specified by CHK-TYPE item.

Caution The following must be kept in mind and the user must be properly informed of the fact when using CHECK-TYPE:

- 0: entire HDD → no operation occurs (to initialize, use the SST)
- 1: image storage area → removes image data
- 2: general-purpose file area (user settings data, various log data, PDL spool data, image data control information) → initializes files
- 3: PDL-related file storage area → removes font data, requiring re-installation
- 4: firmware, address book, filter storage area → no operation occurs (to initialize, use the SST)

- Operation method
- 1) Select this item.
 - 2) Press the OK key.



If you execute <HD-CLEAR> after selecting 1 (image storage area) or 3 (PDL file storage area) for the <CHK-TYPE> item, the initialization process is performed after the power is turned OFF/ON.

The initialization process takes about 5 minutes. A progress bar slowly advances to indicate the progress during this time. Never turn the power OFF during this time.

7.2 FEEDER

SENS-INT

- Used to adjust the initialization of ADF sensors.
- Caution** Execute this item when you have replaced the ADF controller PCB, document placement sensor, pre-registration sensor, final document detection sensor or reverse outlet sensor.
- Note** See the DIP switch function list in Chapter 5, "Troubleshooting" in the DADF-D1/K1 Service Manual.
- Operation method**
- 1) Paste black paper (solid black) on the final document detection sensor in the document tray.
(Make sure the black paper doesn't cover the document placement sensor. The document placement display LED must not light.)
 - 2) Close the ADF, select this item, then press the OK key.
 - 3) After about 15 seconds, the document detection LED flashes twice.
When <SERVICE> in the display changes to <READY>, automatic adjustment is finished. (<SERVICE> appears at the top right of the display during automatic adjustment.)

SPRL-CLN

- Enters separation roller cleaning mode.
- Operation method**
- 1) Place white paper in the ADF's document tray.
 - 2) Select this item, and press the OK key.

REG-CLN

- Enters registration roller cleaning mode.
- Operation method**
- 1) Close the ADF, and check that the paper feed unit cover and reverse paper delivery unit cover are closed.
 - 2) Select this item and press the OK key.
 - 3) Open the paper feed unit cover, and press against the registration roller lightly with a lens paper or cloth soaked in alcohol. (The roller operates for about 40 seconds.)
- Note** During the operation, the roller stops if you close the paper feed unit cover, or open the reverse paper delivery unit cover or ADF.

COPIER>FUNCTION

8 FUNCTION (operation/inspection mode): Level 2

The COPIER>FUNCTION (Level 2) screen is shown below.

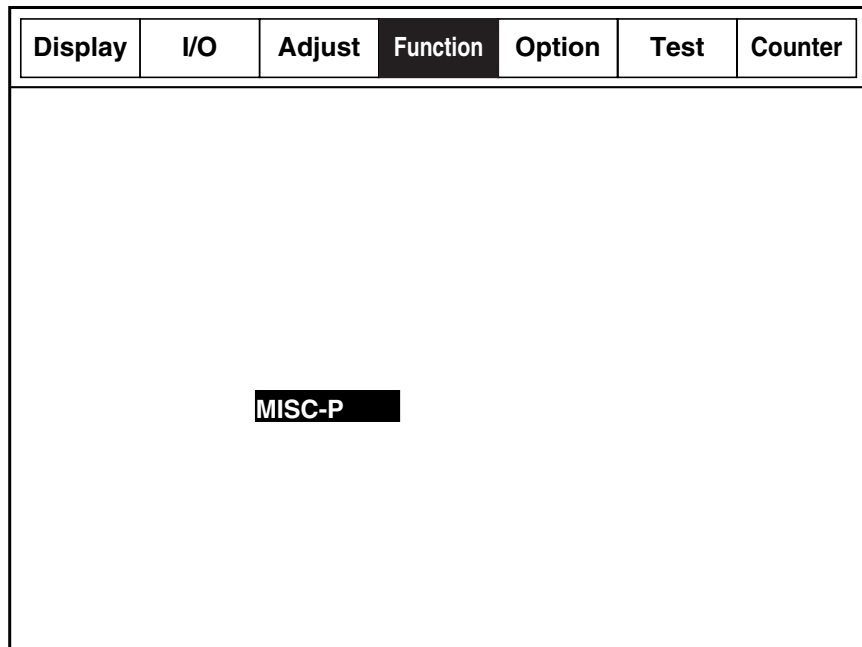

F05-800-01

<MISC-P>

- KEY-HIST (Prints the operation panel's key input history.)
 - 1) Select this item.
 - 2) Press the OK key to start printing.
- HIST-PRT (Prints the jam history and error history.)
 - 1) Select this item.
 - 2) Press the OK key to start printing.
- TRS-DATA (Moves the data received in memory to the BOX.)
 - 1) Select this item.
 - 2) Press the OK key to start printing.

9 OPTION (mechanical specifications setting mode): Level 1

9.1 COPIER

The COPIER>OPTION (Level 1) screen is shown below. The items are described starting on the next page.

Display	I/O	Adjust	Function	Option	Test	Counter
				BODY		
				USER		
				ACC		
				INT-FACE		

F05-901-01

COPIER>OPTION

<BODY>

Used to select copier mechanical specifications.

MODEL-SZ

Used to select standard variable magnification display and ADF document size detection.

Caution The setting value takes effect after the main power switch is turned OFF/ON.

Setting values
0: AB (6R5E)
1: INCH (5R4E)
2: A (3R3E)
3: AB/INCH (6R5E)

PASCAL

Used to select whether to use the contrast electric potential calculated by automatic gradation compensation (full compensation) control, and the gradation compensation data.

Caution

- For printer models, you must always make this setting value 0 at time of installation.
- The setting value takes effect after the power switch is turned OFF/ON.

Setting values
0: Don't use
1: Use (value at time of factory shipment/value after RAM clear)

DLIFE-SW

Used to select light-sensitive drum life display.

Note Use this item to select whether to display drum unit remaining service life.

Setting values
0: Don't display (value at time of factory shipment/value after RAM clear)
1: Display (Drum unit life is displayed by selecting 'System status'> 'Consumable part display' in the user screen.)

CONFIG

Used to select from among multiple sets of firmware stored on the hard disk, to switch the copier's country, language, manufacturer and paper size system.

Caution The setting value takes effect after the main power switch is turned OFF/ON.

Operation method

- 1) Enter the service modes, and select COPIER > OPTION > BODY > CONFIG.
- 2) Select the item to switch, and press the + or -key.
- 3) Each time you press the + or -key, the setting for the selected item changes.
- 4) When you have displayed the desired setting for each item, press the OK key.
- 5) Turn the main power switch OFF/ON.

Setting values	XXYYZZAA
	XX: Country (Example: JP → Japan)
	YY: Language (Example: ja → Japanese)
	ZZ: Manufacturer (Example: 00 → CANON)
	AA: Paper size system (Example: 00 → AB system)

TEMP-TBL

Used to change temperature table for fixing temperature regulation.

Setting values	0: Use normal temperature-regulation table (190°C) (value at time of factory shipment/value after RAM clear)
	1: Use approximately 5°C lower temperature-regulation table (185°C)
	2: Use approximately 10°C lower temperature-regulation table (180°C)

W/SCNR

For copy models, sets whether scanner is present.

Caution	The setting value takes effect after the main power switch is turned OFF/ON.
Setting values	0: Printer model (value after RAM clear)
	1: Model with scanner (value at time of factory shipment)

NW-SPEED

Used to select data transfer speed during the network connection for the service.

Setting values	0: Auto (value at time of factory shipment)
	1: 100Base-TX
	2: 10Base-T

ADJ-LVL

Sets execution mode for image stabilization control performed after preset number of sheets.

Sets execution mode (adjustment set data) for forward/reverse operation of copy or print jobs and image stabilization control done between sheets.

Note	Changing the setting of this item lets you shorten the execution time for image stabilization control, a process executed after a preset number of sheets since the previous adjustment, or in a set time interval.
-------------	---

Setting values	0: Normal mode (value at time of factory shipment/value after RAM clear)
	Adjustment set 1: Discharge current volume control, single-cycle ATVC control, ATR control, image position compensation
	Adjustment set 2: Discharge current volume control, single-cycle ATVC control, ATR control, SALT-Dmax control, image position compensation

COPIER>OPTION**1: Compression mode 1****Adjustment set 1: Discharge current volume control, single-cycle ATVC control, ATR control, image position compensation****Adjustment set 2: Discharge current volume control, single-cycle ATVC control, ATR control, image position compensation****2: Compression mode 2****Adjustment set 1: Nothing****Adjustment set 2: Nothing**

Caution If you select ‘1: Compression mode 1’, the density fluctuation will be greater than if you select ‘0: Normal mode’.

If you select ‘2: Compression mode 2’, you must execute the following item in the user mode: Adjustment/cleaning > automatic gradation compensation (full compensation).

INTROT-1

Sets the execution interval (number of sheets) for image stabilization control (adjustment set 1) during forward/reverse operation.

Sets the interval in which automatic adjustment control (adjustment set 1) is performed during forward/reverse operation of copy or print jobs.

Note If this item is set to a larger value than the setting value for image stabilization control (adjustment set 2) (COPIER > OPTION > BODY > INTROT-2), the setting value for this item is invalid.

When the adjustment set 2 (INTROT-2) process is performed, the adjustment set 1 (INTROT-1) process is considered to have been performed.

The count is reset in the following cases:

- When the number of sheets reaches the specified value
- When an image stabilization control process including the control items executed by this item is performed

Caution Increasing the interval in which the control process is performed may adversely affect the density fluctuation.

When the setting value for the COPIER > OPTION > BODY > ADJ-LVL item is 2, the setting for this item is invalid.

Setting values **50 to 1000 (Value at time of factory shipment/value after RAM clear: 100)**

INTROT-2

Sets the execution interval (number of sheets) for image stabilization control (adjustment set 2) during forward/reverse operation.

Sets the interval in which automatic adjustment control (adjustment set 2) is performed during forward/reverse operation of copy or print jobs.

Note	<p>If this item is set to a smaller value than the setting value for image stabilization control (adjustment set 1) (COPIER > OPTION > BODY > INTROT-1), the setting value for this item is invalid.</p> <p>The count is reset in the following cases:</p> <ul style="list-style-type: none"> • When the number of sheets reaches the specified value • When an image stabilization control process including the control items executed by this item is performed
Caution	<p>Increasing the interval in which the control process is performed may adversely affect the density fluctuation.</p> <p>When the setting value for the COPIER > OPTION > BODY > ADJ-LVL item is 2, the setting for this item is invalid.</p>
Setting values	50 to 1000 (Value at time of factory shipment/value after RAM clear: 500)

INTROT-T

	<p>Sets the execution interval (time) for image stabilization control during standby.</p> <p>Sets the interval in which image stabilization control is performed during standby.</p> <p>The control process is performed after the preset amount of time has elapsed since the last job was performed.</p>
Note	<p>The time count starts after the last job has finished. The time is reset in the following cases:</p> <ul style="list-style-type: none"> • When the time reaches the specified value • When a job is received before the time has reached the specified value <p>To turn image stabilization control during standby ON/OFF, select: COPIER > OPTION > BODY > AUTO-DH</p>
Setting values	1 to 10 (hours) (Value at time of factory shipment/value after RAM clear: 2)

DEVL-PTH

	<p>Sets threshold value (number of sheets) for starting toner forcible consumption sequence.</p> <p>Use this item when copying/printing consecutive images with low color ratios.</p>
Operation method	<p>If the density drops below the set threshold value when copying/printing consecutive low-color-ratio images, once the set number of sheets has been exceeded, the toner forcible consumption sequence is started during the job.</p>
Setting values	<p>0: Don't perform sequence</p> <p>1: About 100 sheets</p> <p>2: About 200 sheets (Value at time of factory shipment/value after RAM clear: 2)</p> <p>3: About 500 sheets</p>

COPIER>OPTION

AUTO-DH

Turns image stabilization control OFF/ON during standby.

Used to turn OFF/ON the image stabilization control operation started by fluctuation in environment during standby, or started after the copier has been idle for an extended period.

Operation method Downtime not intended by the user (when the copier starts up by itself) can be eliminated by turning OFF the image stabilization control operation that starts automatically due to environmental fluctuation during standby or when the copier is idle for an extended period.

Setting values **0: Automatic start OFF (prohibit operation)**

1: Automatic start ON (permit operation)

Note The trigger time setting (in hours) is set by the following service mode item:

COPIER > OPTION > BODY > INTROT-T

Caution If you enter a setting value of 0 (OFF), the user will have to monitor the output image to determine when to execute the following item in the user mode: Adjustment/cleaning > automatic gradation compensation (full compensation).
Other image stabilization control processes are performed independently of this setting.

<USER>

Used to make user-related mechanical specifications settings.

COPY-LIM

Used to change upper limit value setting for number of sheets to copy.

Setting values **1 to 999 sheets (Value at time of factory shipment/value after RAM clear: 999)**

SLEEP

Used to turn sleep function ON/OFF.

Setting values **0: OFF**

1: ON (value at time of factory shipment/value after RAM clear)

Note The sleep function is set by the timer setting in the 'user mode'.

COUNTER 1

Sets user mode screen software counter 1.

Setting values **101: Total 1 (Value at time of factory shipment/value after RAM clear: 1. Fixed value that can't be changed.)**

COUNTER 2

Used to change the counter type display for the operation panel's software counter 2, to meet user or dealer requirements.

Note Lets you change the counter data to meet user or dealer requirements.

Setting values **0 to 999 (Value at time of factory shipment/value after RAM clear: 108)**

COUNTER 3

Used to change the counter type display for the operation panel's software counter 3, to meet user or dealer requirements.

Note Lets you change the counter data to meet user or dealer requirements.

Setting values **0 to 999 (Value at time of factory shipment/value after RAM clear: 232)**

COUNTER 4

Used to change the counter type display for the operation panel's software counter 4, to meet user or dealer requirements.

Note Lets you change the counter data to meet user or dealer requirements.

Setting values **0 to 999 (Value at time of factory shipment/value after RAM clear: 324)**

COUNTER 5

Used to change the counter type display for the operation panel's software counter 5, to meet user or dealer requirements.

Note Lets you change the counter data to meet user or dealer requirements.

Setting values **0 to 999 (Value at time of factory shipment/value after RAM clear: 000)**

COUNTER 6

Used to change the counter type display for the operation panel's software counter 6, to meet user or dealer requirements.

Note Lets you change the counter data to meet user or dealer requirements.

Setting values **0 to 999 (Value at time of factory shipment/value after RAM clear: 000)**

COPIER>OPTION

<Software counter specifications>

The numbers entered for software counters are classified as follows:

100 to 199: Total	500 to 599: Scans
200 to 299: Copies	600 to 699: Box prints
300 to 399: Prints	700 to 799: Received prints
400 to 499: Copies + prints	800 to 899: Report prints

Meanings of symbols in tables

- ○: Valid counter for copier
- 4C: Full-color
- Mono: Monocolor (Y, M, C/R, G, B/retro-style monochrome)
- Bk: Black only
- L: Large size (paper larger than B4 size)
- S: Small size (B4 size and smaller paper)
- 1, 2 in 'Counter description': Numbers of large size paper counts
You can have B4 and larger paper sizes counted as large sizes by selecting the COPIER > OPTION > USER > B4_L_CNT service mode item.
- Copies: Local copies + remote copies
- Copies A: Local copies + remote copies + box prints
- Prints: PDL prints + report prints + box prints
- Prints A: PDL prints + report prints
- Scans: Black and white scans + color scans

Com- patibility	No.	Counter description	Com- patibility	No.	Counter description
	000	No display	○	208	Copies A (small)
○	101	Total 1	○	209	Local copies (total 1)
○	102	Total 2	○	210	Local copies (total 2)
○	103	Total (large)	○	211	Local copies (large)
○	104	Total (small)	○	212	Local copies (small)
○	105	Total (full-color 1)	○	213	Remote copies (total 1)
○	106	Total (full-color 2)	○	214	Remote copies (total 2)
○	108	Total (black and white 1)	○	215	Remote copies (large)
○	109	Total (black and white 2)	○	216	Remote copies (small)
○	110	Total (monocolor/large)	○	217	Copies (full-color 1)
○	111	Total (monocolor/small)	○	218	Copies (full-color 2)
○	112	Total (black and white/large)	○	219	Copies (monocolor 1)
○	113	Total (black and white/small)	○	220	Copies (monocolor 2)
○	114	Total 1 (two-sided)	○	221	Copies (black and white 1)
○	115	Total 2 (two-sided)	○	222	Copies (black and white 2)
○	116	Large (two-sided)	○	223	Copies (full-color/large)
○	117	Small (two-sided)	○	224	Copies (full-color/small)
○	118	Total (monocolor 1)	○	225	Copies (monocolor/large)
○	119	Total (monocolor 2)	○	226	Copies (monocolor/small)
○	120	Total (full-color/large)	○	227	Copies (black and white/large)
○	121	Total (full-color/small)	○	228	Copies (black and white/small)
○	122	Total (full-color + monocolor/ large)	○	229	Copies (full-color + monocolor/ large)
○	123	Total (full-color + monocolor/ small)	○	230	Copies (full-color + monocolor/ small)
○	124	Total (full-color + monocolor 2)	○	231	Copies (full-color + monocolor/2)
○	125	Total (full-color + monocolor 1)	○	232	Copies (full-color + monocolor/1)
○	201	Copies (total 1)	○	233	Copies (full-color/large/two-sided)
○	202	Copies (total 2)	○	234	Copies (full-color/small/two-sided)
○	203	Copies (large)	○	235	Copies (monocolor/large/ two-sided)
○	204	Copies (small)			
○	205	Copies A (total 1)	○	236	Copies (monocolor/small/ two-sided)
○	206	Copies A (total 2)			
○	207	Copies A (large)	○	237	Copies (black and white/large/ two-sided)

T05-901-01

COPIER>OPTION

Com- patibility	No.	Counter description	Com- patibility	No.	Counter description
○	238	Copies (black and white/small/ two-sided)	○	275	Local copies (monocolor 1)
○	245	Copies A (full-color 1)	○	276	Local copies (monocolor 2)
○	246	Copies A (full-color 2)	○	277	Local copies (black and white 1)
○	247	Copies A (monocolor 1)	○	278	Local copies (black and white 2)
○	248	Copies A (monocolor 2)	○	279	Local copies (full-color/large)
○	249	Copies A (black and white 1)	○	280	Local copies (full-color/small)
○	250	Copies A (black and white 2)	○	281	Local copies (monocolor/large)
○	251	Copies A (full-color/large)	○	282	Local copies (monocolor/small)
○	252	Copies A (full-color/small)	○	283	Local copies (black and white/ large)
○	253	Copies A (monocolor/large)	○	284	Local copies (black and white/ small)
○	254	Copies A (monocolor/small)	○	285	Local copies (full-color + mono- color/large)
○	255	Copies A (black and white/large)	○	286	Local copies (full-color + mono- color/small)
○	256	Copies A (black and white/ small)	○	287	Local copies (full-color + mono- color 2)
○	257	Copies A (full-color + mono- color/large)	○	288	Local copies (full-color + mono- color 1)
○	258	Copies A (full-color + mono- color/small)	○	289	Local copies (full-color/large/ two-sided)
○	259	Copies A (full-color + mono- color 2)	○	290	Local copies (full-color/small/ two-sided)
○	260	Copies A (full-color + mono- color 1)	○	291	Local copies (monocolor/large/ two-sided)
○	261	Copies A (full-color/large/ two-sided)	○	292	Local copies (monocolor/small/ two-sided)
○	262	Copies A (full-color/small/ two-sided)	○	293	Local copies (black and white/ large/two-sided)
○	263	Copies A (monocolor/large/ two-sided)	○	294	Local copies (black and white/ small/two-sided)
○	264	Copies A (monocolor/small/ two-sided)	○	002	Remote copies (full-color 1)
○	265	Copies A (black and white/ large/two-sided)	○	003	Remote copies (full-color 2)
○	266	Copies A (black and white/ small/two-sided)	○	004	Remote copies (monocolor 1)
○	273	Local copies (full-color 1)	○	005	Remote copies (monocolor 2)
○	274	Local copies (full-color 2)	○	006	Remote copies (black and white 1)

T05-901-02

Com- patibility	No.	Counter description	Com- patibility	No.	Counter description
○	007	Remote copies (black and white 2)	○	303	Prints (large)
○	008	Remote copies (full-color/large)	○	304	Prints (small)
○	009	Remote copies (full-color/small)	○	305	Prints A (total 1)
○	010	Remote copies (monocolor/large)	○	306	Prints A (total 2)
○	011	Remote copies (monocolor/small)	○	307	Prints A (large)
○	012	Remote copies (black and white/large)	○	308	Prints A (small)
○	013	Remote copies (black and white/small)	○	309	Prints (full-color 1)
○	014	Remote copies (full-color + monocolor/large)	○	310	Prints (full-color 2)
○	015	Remote copies (full-color + monocolor/small)	○	311	Prints (monocolor 1)
○	016	Remote copies (full-color + monocolor 2)	○	312	Prints (monocolor 2)
○	017	Remote copies (full-color + monocolor 1)	○	313	Prints (black and white 1)
○	018	Remote copies (full-color/large/two-sided)	○	314	Prints (black and white 2)
○	019	Remote copies (full-color/small/two-sided)	○	315	Prints (full-color/large)
○	020	Remote copies (monocolor/large/two-sided)	○	316	Prints (full-color/small)
○	021	Remote copies (monocolor/small/two-sided)	○	317	Prints (monocolor/large)
○	022	Remote copies (black and white/large/two-sided)	○	318	Prints (monocolor/small)
○	023	Remote copies (black and white/small/two-sided)	○	319	Prints (black and white/large)
○	301	Prints (total 1)	○	320	Prints (black and white/small)
○	302	Prints (total 2)	○	321	Prints (full-color + monocolor/large)
			○	322	Prints (full-color + monocolor/small)
			○	323	Prints (full-color + monocolor/2)
			○	324	Prints (full-color + monocolor/1)
			○	325	Prints (full-color/large/two-sided)
				326	Prints (full-color/small/two-sided)
			○	327	Prints (monocolor/large/two-sided)
			○	328	Prints (monocolor/small/two-sided)
			○	329	Prints (black and white/large/two-sided)
			○	330	Prints (black and white/small/two-sided)
			○	331	PDL prints (total 1)
			○	332	PDL prints (total 2)
			○	333	PDL prints (large)
			○	334	PDL prints (small)

T05-901-03

COPIER>OPTION

Com- patibility	No.	Counter description	Com- patibility	No.	Counter description
○	335	PDL prints (full-color 1)	○	411	Copies + prints (large)
○	336	PDL prints (full-color 2)	○	412	Copies + prints (small)
○	339	PDL prints (black and white 1)	○	413	Copies + prints (2)
○	340	PDL prints (black and white 2)	○	414	Copies + prints (1)
○	341	PDL prints (full-color/large)	○	415	Copies + prints (monocolor/large)
○	342	PDL prints (full-color/small)	○	416	Copies + prints (monocolor/small)
○	345	PDL prints (black and white/ large)	○	417	Copies + prints (full-color/large/ two-sided)
○	346	PDL prints (black and white/ small)	○	418	Copies + prints (full-color/small/ two-sided)
○	351	PDL prints (full-color/large/ two-sided)	○	419	Copies + prints (monocolor/large/ two-sided)
○	352	PDL prints (full-color/small/ two-sided)	○	420	Copies + prints (monocolor/small/ two-sided)
○	355	PDL prints (black and white/ large/two-sided)	○	421	Copies + prints (black and white/ large/two-sided)
○	356	PDL prints (black and white/ small/two-sided)	○	422	Copies + prints (black and white/ small/two-sided)
○	401	Copies + prints (full-color/ large)	○	501	Scans (total 1)
○	402	Copies + prints (full-color/ small)	–	502	Scans (total 2)
○	403	Copies + prints (black and white/large)	–	503	Scans (large)
○	404	Copies + prints (black and white/small)	–	504	Scans (small)
○	405	Copies + prints (black and white 2)	○	505	Black and white scans (total 1)
○	406	Copies + prints (black and white 1)	–	506	Black and white scans (total 2)
○	407	Copies + prints (full-color + monocolor/large)	–	507	Black and white scans (large)
○	408	Copies + prints (full-color + monocolor/small)	–	508	Black and white scans (small)
○	409	Copies + prints (full-color + monocolor/2)	○	509	Color scans (total 1)
○	410	Copies + prints (full-color + monocolor/1)	–	510	Color scans (total 2)
			–	511	Color scans (large)
			–	512	Color scans (small)
			○	601	Box prints (total 1)
			○	602	Box prints (total 2)
			○	603	Box prints (large)
			○	604	Box prints (small)
			○	605	Box prints (full-color 1)
			○	606	Box prints (full-color 2)
			○	607	Box prints (monocolor 1)
			○	608	Box prints (monocolor 2)

T05-901-04

Com- patibility	No.	Counter description	Com- patibility	No.	Counter description
○	609	Box prints (black and white 1)	–	708	Received prints (gray scale 2)
○	610	Box prints (black and white 2)	○	709	Received prints (black and white 1)
○	611	Box prints (full-color/large)			
○	612	Box prints (full-color/small)	○	710	Received prints (black and white 2)
○	613	Box prints (monocolor/large)			
○	614	Box prints (monocolor/small)	–	711	Received prints (full-color/large)
○	615	Box prints (black and white/large)	–	712	Received prints (full-color/small)
○	616	Box prints (black and white/small)	–	713	Received prints (gray scale/large)
○	617	Box prints (full-color + monochrome/large)	–	714	Received prints (gray scale/small)
○	618	Box prints (full-color + monochrome/small)	○	715	Received prints (black and white/large)
○	619	Box prints (full-color + monochrome 2)	○	716	Received prints (black and white/small)
○	620	Box prints (full-color + monochrome 1)	–	717	Received prints (full-color + gray scale/large)
○	621	Box prints (full-color/large/two-sided)	–	718	Received prints (full-color + gray scale/small)
○	622	Box prints (full-color/small/two-sided)	–	719	Received prints (full-color + gray scale 2)
○	623	Box prints (monocolor/large/two-sided)	–	720	Received prints (full-color + gray scale 1)
○	624	Box prints (monocolor/small/two-sided)	–	721	Received prints (full-color/large/two-sided)
○	625	Box prints (black and white/large/two-sided)	–	722	Received prints (full-color/small/two-sided)
○	626	Box prints (black and white/small/two-sided)	–	723	Received prints (gray scale/large/two-sided)
○	701	Received prints (total 1)	–	724	Received prints (gray scale/small/two-sided)
○	702	Received prints (total 2)	○	725	Received prints (black and white/large/two-sided)
○	703	Received prints (large)	○	726	Received prints (black and white/small/two-sided)
○	704	Received prints (small)	○	801	Report prints (total 1)
–	705	Received prints (full-color 1)	○	802	Report prints (total 2)
–	706	Received prints (full-color 2)	○	803	Report prints (large)
–	707	Received prints (gray scale 1)	○	804	Report prints (small)

T05-901-05

COPIER>OPTION

Com- patibility	No.	Counter description	Com- patibility	No.	Counter description
-	805	Report prints (full-color 1)	-	902	Copy scan total 1 (black and white)
-	806	Report prints (full-color 2)			
-	807	Report prints (gray scale 1)	-	903	Copy scan total 2 (color)
-	808	Report prints (gray scale 2)	-	904	Copy scan total 2 (black and white)
○	809	Report prints (black and white 1)	-	905	Copy scan total 3 (color)
○	810	Report prints (black and white 2)	-	906	Copy scan total 3 (black and white)
-	811	Report prints (full-color/large)	-	907	Copy scan total 4 (color)
-	812	Report prints (full-color/small)	-	908	Copy scan total 4 (black and white)
-	813	Report prints (gray scale/large)			
-	814	Report prints (gray scale/small)	-	909	Local copy scans (color)
○	815	Report prints (black and white/large)	-	910	Local copy scans (black and white)
○	816	Report prints (black and white/small)	-	911	Remote copy scans (color)
-	817	Report prints (full-color + gray scale/large)	-	912	Remote copy scans (black and white)
-	818	Report prints (full-color + gray scale/small)	-	913	Sent scan total 1 (color)
-	819	Report prints (full-color + gray scale 2)	-	914	Sent scan total 1 (black and white)
-	820	Report prints (full-color + gray scale 1)	○	915	Sent scan total 2 (color)
-	821	Report prints (full-color/large/two-sided)	○	916	Sent scan total 2 (black and white)
-	822	Report prints (full-color/small/two-sided)	○	917	Sent scan total 3 (color)
-	823	Report prints (gray scale/large/two-sided)	○	918	Sent scan total 3 (black and white)
-	824	Report prints (gray scale/small/two-sided)	-	919	Sent scan total 4 (color)
○	825	Report prints (black and white/large/two-sided)	-	920	Sent scan total 4 (black and white)
○	826	Report prints (black and white/small/two-sided)	○	921	Sent scan total 5 (color)
			○	922	Sent scan total 5 (black and white)
			○	929	Sent scan total 6 (color)
			○	930	Sent scan total 6 (black and white)
			-	931	Sent scan total 7 (color)
			-	932	Sent scan total 7 (black and white)
			-	933	Sent scan total 8 (color)
			-	934	Sent scan total 8 (black and white)
			-	935	Universal sent scan total (color)
			-	936	Universal sent scan total (black and white)
-	901	Copy scan total 1 (color)			

T05-901-06

Com- patibility	No.	Counter description	Com- patibility	No.	Counter description
○	937	Box scans (color)	–	948	Sent scans/FTP (black and white)
○	938	Box scans (black and white)	–	949	Sent scans/SMB (color)
○	939	Remote scans (color)	–	950	Sent scans/SMB (black and white)
○	940	Remote scans (black and white)			
–	941	Sent scans/faxes (color)	–	951	Sent scans/IPX (color)
–	942	Sent scans/faxes (black and white)	–	952	Sent scans/IPX (black and white)
–	943	Sent scans/I faxes (color)	–	953	Sent scans/databases (color)
–	944	Sent scans/I faxes (black and white)	–	954	Sent scans/databases (black and white)
○	945	Sent scans/e-mails (color)	–	955	Sent scans/local prints (color)
○	946	Sent scans/e-mails (black and white)	–	956	Sent scans/local prints (black and white)
–	947	Sent scans/FTP (color)	–	957	Sent scans/box (color)
			–	958	Sent scans/box (black and white)

T05-901-07

COPIER>OPTION

B4-L-CNT

Used to select whether to count B4 size paper as large size or small size for software counters 1 to 6.

Setting values **0: Small size (value at time of factory shipment/value after RAM clear)**
1: Large size

COPY-JOB

Prohibits copy job reservations when card reader and coin vendor are in use.

Setting values **0: Copy job reservations (value at time of factory shipment/value after RAM clear)**
1: No copy job reservations

TAB-ROT

Rotates landscape images on PDL tab paper 180 degrees.

Setting values **0: Don't rotate (value at time of factory shipment/value after RAM clear)**
1: Rotate

IDPRN-SW

Used to switch type of count-up job for department management counter.

Setting values **0: BoxPrint, ReportPrint, SendLocalPrint and PDLPrint are counted as PRINT categories (value at time of factory shipment/value after RAM clear)**
1: Only PDLPrint is counted as a PRINT category

CPRT-DSP

Used to select whether to display count print button in sales counter check screen, for Lawson models.

Setting values **0: Don't display (This setting is only for stores that request it.)**
1: Display (Count print function can be used.)
(Value at time of factory shipment/value after RAM clear)

<ACC>

Used to make options-related mechanical specifications settings.

COIN

Used to switch coin vendor setting.

Setting values **0: OFF (value at time of factory shipment)**
1: ON

DK-P

Used to set paper size used by paper deck (option).

Setting values **0: A4 (value at time of factory shipment)**
1: B5
2: LTR

CARD-SW

Used to select UI screen when coin vendor is supported.

Setting values **0: Coin (value at time of factory shipment)**
1: Card
2: Coin + card

<INT-FACE>

Used to set conditions when copier is connected to external controller.

IMG-CONT

Used to set connection to PS print server unit.

Setting values **0: Normal mode (no PS print server unit) (value at time of factory shipment)**
1: Not used
2: Not used
3: PS print server unit
4: Not used
5: Not used

Caution

When 1 is selected as the setting value, the following user mode items are restored to their initial values:

- System management settings > Network settings > TCP/IP settings > IP address settings > IP address
- System management settings > Network settings > TCP/IP settings > IP address settings > Sub-net mask
- System management settings > Network settings > TCP/IP settings > IP address settings > Gateway address

COPIER>OPTION

- System management settings > Network settings > Ethernet driver settings > Communication method
- System management settings > Network settings > Ethernet driver settings > Ethernet type
- System management settings > Network settings > Startup time
- Common specifications settings

The following user mode settings are turned OFF:

- System management settings > Network settings > TCP/IP settings > IP address settings > DHCP use
- System management settings > Network settings > TCP/IP settings > IP address settings > RARP use
- System management settings > Network settings > TCP/IP settings > IP address settings > BOOTP use
- System management settings > Network settings > Ethernet driver settings > Automatic detection
- System management settings > Network settings > Spool function use

When 3 or 4 is selected as the setting value, the following settings are turned OFF in addition to the items above.

- System management settings > Network settings > TCP/IP settings > RAW setting
- System management settings > Network settings > TCP/IP settings > LPD setting
- System management settings > Network settings > TCP/IP settings > IPP printing
- System management settings > Network settings > SMB setting

The items above are not restored when the setting value is returned to '0: Normal mode', so must be set again as needed.

9.2 SORTER

BLNK-SW

Used to set blank width (W) on both sides of fold position when saddle stitcher is in use.

**Setting
values**

0: Normal width (5 mm),

1: Large width (10 mm) (value at time of factory shipment)

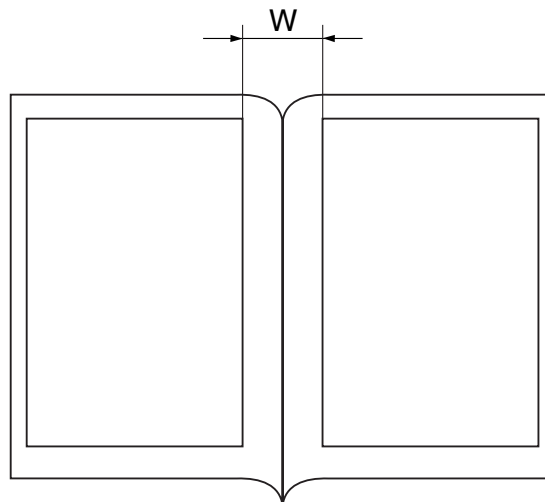

F05-902-01

9.3 BOARD

SURF-OFF

Releases UFR board function.

**Setting
values**

0: Even without UFR board, copier operates as copy model without displaying E codes.

1: UFR board recognition check is performed. If no UFR board exists, E codes are displayed.

COPIER>OPTION

10 OPTION (mechanical specifications setting mode): Level 2

The COPIER>OPTION (Level 2) screen is shown below.

Display	I/O	Adjust	Function	Option	Test	Counter
<p>BODY</p> <p>USER</p> <p>CST</p> <p>ACC</p> <p>INT-FACE</p>						

F05-1000-01

<BODY>

- SCANSLCT (Used to turn ON/OFF function that calculates scan area from selected paper size.)
 - 0: OFF (Scan area is determined by document detection.)
(Value at time of factory shipment/value after RAM clear)
 - 1: ON (Scan area is determined by paper size.)
- RAW-DATA (Sets whether to print out raw received data.)
 - 0: Normal operation (value at time of factory shipment/value after RAM clear)
 - 1: Print out raw received data
- RMT-LANG (Used to select language of remote UI used from Web.)
Select language code with + and –keys.
- IFAX-LIM (Used to select whether number of output lines will be restricted when large-volume data is received by IFAX.)
 - 0: No restriction
 - 1 to 999 (Value at time of factory shipment/value after RAM clear: 500)

- TC-REF (Used to turn ON/OFF environmental compensation on ATR sensor output)
Normally, the ATR sensor output value used is the value compensated for the environment.
0: Environmental compensation OFF
1: Environmental compensation ON (value at time of factory shipment/value after RAM clear)
If fogging occurs in a low-humidity environment, set this item to 0.
- SMTPTXPN (Used to change SMTP send port number.)
0 to 65535 (increments of 1) (Value at time of factory shipment/value after RAM clear: 25)
- SMTPRXPN (Used to change SMTP receive port number.)
0 to 65535 (increments of 1) (Value at time of factory shipment/value after RAM clear: 25)
- POP3PN (Used to change POP receive port number.)
0 to 65535 (increments of 1) (Value at time of factory shipment/value after RAM clear: 110)
- RUI-DSP (Used to select copy function in remote UI.)
0: Display copy screen in remote UI (value at time of factory shipment/value after RAM clear).
1: Don't display copy screen in remote UI.
- ORG-LGL (Used to set special paper size not compatible with DF size recognition.)
0: LEGAL (value at time of factory shipment/value after RAM clear)
1: G-LEGAL
2: FOOLSCAP
3: A-FOOLSCAP
4: FORIO
5: OFFICIO
6: E-OFFICIO
7: A-OFFICIO
8: M-OFFICIO
9: B-OFFICIO
- ORG-LTR (Used to set special paper size not compatible with DF size recognition.)
0: LTR (value at time of factory shipment/value after RAM clear)
1: G-LTR
2: A-LTR
3: EXECUTIVE
- ORG-LTRR (Used to set special paper size not compatible with DF size recognition.)
0: LTR-R (value at time of factory shipment/value after RAM clear)
1: G-LTR-R
2: A-LTR-R
3: EXECUTIVE-R

COPIER>OPTION

- UI-BOX (Used to select whether to display operation panel box screen.)
 - 0: Don't display
 - 1: Display (value at time of factory shipment/value after RAM clear)
- UI-SEND (Used to select whether to display operation panel send screen.)
 - 0: Don't display
 - 1: Display (value at time of factory shipment/value after RAM clear)
- UI-FAX (Used to select whether to display operation panel fax screen.)
 - 0: Don't display
 - 1: Display (value at time of factory shipment/value after RAM clear)
- UI-EXT (Used to select whether to display operation panel extension screen.)
 - 0: Don't display
 - 1: Display (value at time of factory shipment/value after RAM clear)
- C4HTR-DT (Cassette heater: Sets lighting ratio of cassette on 4th level.)
Whenever possible, avoid using this setting during normal operation.
- C2HTR-DT (Cassette heater: Sets lighting ratio of cassette on 2nd level.)
Whenever possible, avoid using this setting during normal operation.
- Y-PTN (Used to eliminate 100 mm horizontal lines.)
 - 0: Don't imprint Y dot patterns on intermediate transfer belt.
 - 1: Imprint Y dot patterns on intermediate transfer belt (only when reading color documents; value at time of factory shipment/value after RAM clear).
 - 2: Imprint more Y dot patterns on intermediate transfer belt than when value of 1 is set.
K dot patterns are imprinted on intermediate transfer belt during monochrome document reading only when value of 2 is set.
- NEGA-GST (Sets additional pre-exposure (using laser) sequence.)
 - 0: Don't perform laser pre-exposure operation (value at time of factory shipment/value after RAM clear)
 - 1: Perform laser pre-exposure operation
 - 2: Perform laser pre-exposure operation between sheets.
- SCR-SLCT (Used to select half-tone process for photographic printing paper/photo mode.)
 - 0: Use error diffusion method
 - 1: Use low-line-count screen (value at time of factory shipment/value after RAM clear)
 - 2: Use high-line-count screen
- TMC-SLCT (Used to select coefficient used in error diffusion process.)
 - 0: Low granularity/low dot stability for Y/M/C/Bk
 - 1: Y/M/C → Low granularity, low dot stability, Bk → high granularity, low dot stability (value at time of factory shipment/value after RAM clear)
 - 2: Low granularity/low dot stability for Y/M/C/Bk

- **LOW-DZL** (Used to change document illumination lamp lighting (document size detection operation) time.)
 - 0: Normal operation (value at time of factory shipment/value after RAM clear)
 - 1: Dazzle reduction mode (Document illumination lamp is lit only once momentarily to detect document size.)
- **D-CLN-TM** (Cleans light-sensitive drum surface.)
 - Whenever possible, avoid using this setting during normal operation.
- **CAL-SW** (Used to switch condition for executing calibration control.)
 - Whenever possible, avoid using this setting during normal operation.
- **CLN-PTH** (Sets threshold value (number of sheets) for starting drum cleaning sequence.)
 - Whenever possible, avoid using this setting during normal operation.
- **CLN-VTH** (Sets threshold value (image density) for starting drum cleaning sequence.)
 - Whenever possible, avoid using this setting during normal operation.
- **DEVL-VTH** (Sets threshold value (video count) for starting toner forcible consumption sequence.)
 - Whenever possible, avoid using this setting during normal operation.
- **FTPTXPN** (Used to specify port (FTP) number to send to.)
 - 0 to 65535 (16-bit value) (Value at time of factory shipment/value after RAM clear: 21)
- **PRNT-ORD** (Used to switch order of output to side tray.)
 - Whenever possible, avoid using this setting during normal operation.
- **SLPOFF01 to 12** (Used to turn sleep mode OFF as way to eliminate condensation: January to December.)
 - Whenever possible, avoid using these settings during normal operation.
- **INTPPR-1** (Sets interval (number of sheets) for executing image stabilization control (adjustment set 1) between sheets.)
 - 0.50 to 1000 (Value at time of factory shipment/value after RAM clear: 100)
- **DWNSQ-SW** (Used to improve tray loading during one-sided continuous printing.)
 - Whenever possible, avoid using this setting during normal operation.
- **IMG-OFF** (Forcibly adds trailing-edge blank on second side of two-sided sheets.)
 - Whenever possible, avoid using this setting during normal operation.
- **PRN-FLG** (Used to select area flag for PDL images.)
 - Whenever possible, avoid using this setting during normal operation.
- **SCN-FLG** (Used to select area flag for copy images.)
 - Whenever possible, avoid using this setting during normal operation.
- **T-LW-LVL** (Used to switch timing for display of remaining toner volume warning message.)
 - Whenever possible, avoid using this setting during normal operation.
- **DVTGT-Y/M/C/K** (developer concentration target value offsets)
 - Whenever possible, avoid using these settings during normal operation.

COPIER>OPTION

- NWERR-SW (Used to select whether to display network error messages.)
 - 0: Don't display
 - 1: Display (value at time of factory shipment/value after RAM clear)
- FX-SPD (Used to adjust fixing roller speed.)
 - 2 to 2 (Value at time of factory shipment/value after RAM clear: 0)
 - Increasing the setting value increases the fixing roller's speed (in 0.8% increments). Setting this value automatically increases the operation speed of the paper delivery vertical path motor (the speed increases by the same ratio as the speed of the fixing roller).
- EX-PS-SP (Used to adjust paper delivery vertical path motor speed.)
 - 2 to 2 (Value at time of factory shipment/value after RAM clear: 0)
- FX-N-ROT (Used to turn fixing motor idle after warmup ON/OFF.)
 - 0: ON (idle) (value at time of factory shipment/value after RAM clear)
 - 1: OFF (don't idle)
 - Setting this value to 1 increases the amount of paper curl, and reduces the capacity for the load on the paper delivery tray.
- FX-SUB (Sets the fixing sub-heater's lighting ratio.)
 - 0: Normal (value at time of factory shipment/value after RAM clear)
 - 1: Level 1
 - 2: Level 2
 - Increasing this setting value decreases the lighting ratio (shortens the lighting time).
- SLV-UP (Used to increase developing cylinder operation speed.)
 - 0: Normal (value at time of factory shipment/value after RAM clear)
 - 1: Operate developing cylinder at 120% of normal speed.
 - 2: Operate developing cylinder at 120% of normal speed and expand interval between sheets as well.
 - Setting this value to 2 decreases productivity (→ 24 ppm).
- STS-PORT (Used to turn TOT asynchronous status communication port ON/OFF.)
 - For future expansion
- CMD-PORT (Used to turn TOT synchronous command communication port ON/OFF.)
 - For future expansion
- BK-4CSW (Used to select color mode used in photo mode.)
 - 0: OFF (Use monochrome mode when reading monochrome documents in printed photo or photographic printing paper photo mode.)
 - 1: ON (Use simple color mode when reading monochrome documents in printed photo or photographic printing paper photo mode.)
 - Instead of creating monochrome images in 4 colors, simple color mode applies only a very small amount of Y/M/C toner to the ITB.

<USER>

- SIZE-DET (Used to turn document size detection function ON/OFF.)
 - 0: OFF
 - 1: ON (value at time of factory shipment/value after RAM clear) (When pressure plate opens/closes, optics don't light, eliminating dazzle.)

- DATE-DSP (Used to switch date display.)
 - 0: 'YYMM/DD
 - 1: DD/MM'YY
 - 2: MM/DD/YY
- MB-CCV (Used to select whether to restrict mailbox control card users.)
 - 0: Don't restrict
 - 1: Restrict
- TRY-STP (Used to set mode in which output stops when tray is full.)
 - 0: Normal mode (Interrupted when finisher tray is full.)
 - 1: Interrupted only by height detection
- CNT-DSP (Used to select whether to display serial number when counter check key is pressed.)
 - 0: Display serial number.
 - 1: Don't display serial number.
- OP-SZ-DT (Used to turn document size detection when pressure plate is open ON/OFF.)
 - 0: Enter document size in control panel.
 - 1: Detect document when start key is turned ON with pressure plate open.
- NW-SCAN (Used to select whether to permit network scan function.)
 - 0: Don't permit
 - 1: Permit (Invalid when UFR board or open interface board isn't connected.)
- HDCR-DSP (Used to turn off display of user mode hard disk clear mode and switch clear operations.)
 - 0: Don't display and don't clear
 - 1: Clear once with zeroes
 - 2: Clear once with random data
 - 3: Clear 3 times with random data (mode displayed for settings 1 to 3)
- JOB-INVL (Used to set job interval during interrupt.)
 - 0: Standard setting (Output next job continuously during interrupt copy job.)
 - 1: Start output of next job after last sheet of interrupt copy job has been delivered.
 - 2: Start output of next job after last sheet of any job has been delivered.
- LGSW-DSP (Used to select whether to display 'Log display ON/OFF setting' on user mode screen.)
 - 0: Don't display 'Log display ON/OFF setting'
 - 1: Display 'Log display ON/OFF setting'
- P-CRG-LF (Used to select operation performed when drum unit has reached end of service life.)
 - 0: Don't stop
 - 1: Stop

COPIER>OPTION

- PCL-COPY (Used to set compatible mode for ‘COPIES’ PCL command.)
 - 0: Perform control on each page individually, according to value of COPIES command specified for each page (value at time of factory shipment/value after RAM clear).
 - 1: Compatible (other controller) mode (not in use)
 - 2: Reserved

<ACC>

- STPL-LMT (Used to restrict number of sheets for saddle binding.)
 - 0: 5 sheets (no white band)
 - 1: 10 sheets (no white band)
 - 2: 10 sheets (white band)
 - 3: 15 sheets (no white band) (value at time of factory shipment/value after RAM clear)
- DF-MUTE (DADF silent reading mode)
 - 0: Normal mode (750 mm/s) (value at time of factory shipment/value after RAM clear)
 - 1: Silent mode (420 mm/s)
- SC-TYPE (Used to switch type of coin vendor-compatible model)
Whenever possible, avoid using this setting during normal operation.

<INT-FACE>

- AP-OPT (Used to set whether printing from application PrintMe in PS print server unit is possible.)
 - 0: Printing permitted for all department IDs (value at time of factory shipment/value after RAM clear)
 - 1: Printing refused (printing is only possible for specified department ID).
- AP-ACCNT (Used to set (CPCA) department ID for printing (print jobs) from application PrintMe in PS print server unit.)
 - 0 to 9999999 (Value at time of factory shipment/value after RAM clear: 0)
- AP-CODE (Used to set (CPCA) pass code for printing (print jobs) from application PrintMe in PS print server unit.)
 - 0 to 9999 (Value at time of factory shipment/value after RAM clear: 0)

<CST>

- U1-NAME (Used to turn paper name display when U1 paper size group is detected ON/OFF.)
 - 0: Display ‘U1’ on touch panel (default).
 - 1: Display paper name set by ‘CST-U1’ service mode item.
- U2-NAME (Used to turn paper name display when U2 paper size group is detected ON/OFF.)
 - 0: Display ‘U2’ on touch panel (default).
 - 1: Display paper name set by ‘CST-U2’ service mode item.
- CST-U1 (Used to specify paper name used by U1 paper size group.)
- CST-U2 (Used to specify paper name used by U2 paper size group.)
 - 24: FOOLSCAP (CST-U2: Default)
 - 25: Australian FOOLSCAP
 - 26: OFFICIO
 - 27: Ecuador OFFICIO
 - 28: Bolivia OFFICIO
 - 29: Argentine LETTER
 - 30: Argentine LETTER-R
 - 31: Government LETTER
 - 32: Government LETTER-R
 - 34: Government LEGAL
 - 35: FOLIO
 - 36: Argentine OFFICIO
 - 37: Mexico OFFICIO
 - 38: EXECUTIVE (CST-U2: Default)

The BOARD>OPTION Level 2 items are described below.

- MENU-1 to 4 (Used to select whether to display Levels 1 to 4 of printer settings menu.)
 - 0: Don't display (value at time of factory shipment/value after RAM clear)
 - 1: Display
- TR-DSP (Used to select whether to display toner reduction function switch.)
Whenever possible, avoid using this setting during normal operation.

COPIER>TEST

11 TEST (test print mode)

The COPIER/PRINTER>TEST screen is shown below. The items are described starting on the next page.

Display	I/O	Adjust	Function	Option	Test	Counter
					PG	
					NETWORK	

F05-1100-01

<PG>

Used to make test print settings.

TYPE

Performs test print when test print type number is entered and start key is turned ON. (This setting must always be restored to 0 after making test print.)

Setting values **0: Normal print, 0 to 100: See T05-1100-01.**

TXPH

Used to set image mode during test print output.

Setting values **0: Text mode**
1: Photo mode
2: Automatic mode
3: Text/photo/map mode
4: Photographic printing paper photo mode
5: Printed photo mode
6: Text/photo mode
7: Black and white text mode

Note This setting is only valid for test prints.

THRU

Used to select whether to use image compensation table during test print output.

Setting values **0: ON (Use), 1: OFF (Don't use)**

DENS-Y, DENS-M, DENS-C, DENS-K

Used to adjust density of each color for test prints (TYPE = 5).

Setting values **0 to 255: Increasing the value increases the density.**

COLOR-Y, COLOR-M, COLOR-C, COLOR-K

Used to set output of each color for each TYPE.

For example, to set single-color M output, set 'COLOR-M = 1', and make the other settings 0 (only single colors can be output).

Setting values **0: Don't output, 1: Output**

COPIER>TEST

PG-PICK

Used to select output level during test print output.

Setting values

- 1: Cassette 1**
- 2: Cassette 2**
- 3: Cassette 3**
- 4: Cassette 4**
- 5 to 6: Not used**
- 7: Side deck**
- 8: Manual feed**

• Type of test print for each number entered for PG>TYPE

Entered number	Description	Entered number	Description
0	Image from CCD (normal print)	8	For development
1	For development	9	For development
2	For development	10	MCYBk horizontal stripes
3	For development	11	For development
4	16 gradations	12	YMCKBk 64 gradations
5	Full-sheet half tones	13	For development
6	Grid	14	Full-color 16 gradations
7	For development	15 to 100	For development

T05-1100-01

<NETWORK>

Used to check network connections.

PING

Checks connection between copier and network (during TCP/IP connection only).

Caution Use this item when checking the connection to the network at time of installation or when there is a network connection problem.

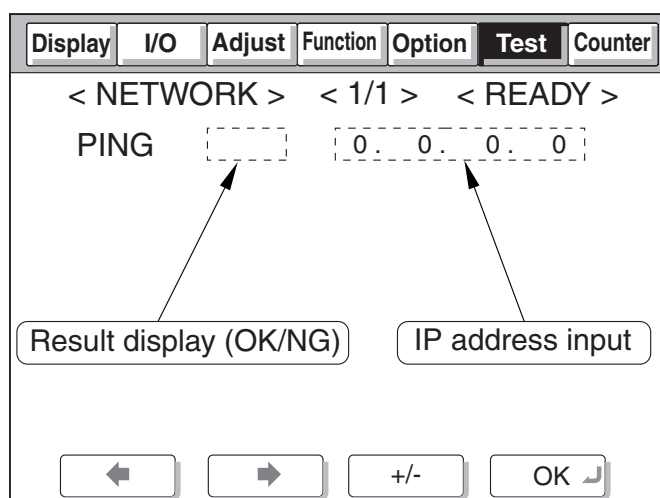

F05-1100-02

- Operation method**
- 1) Turn the main power switch OFF.
 - 2) Connect the network cable to the copier and turn the main power switch ON.
 - 3) Tell the user's system administrator that copier installation is complete, and have them him/her the network settings.
 - 4) Ask the system administrator to allow you to perform a network connection check, and check the address of the remote host (IP address of the PC terminal in the user network) to send the PING.
 - 5) Select the COPIER > TEST > NETWORK > PING service mode item, enter the IP address checked in Step 4 on the operation panel's numeric keypad, and press the OK key.
 - If the copier is connected to the network normally, "OK" is displayed (and the procedure is finished).
 - If "NG" is displayed, first check the connection of the network cable. If the connection is normal, go to Step 6. If there is a problem with the network cable's connection, redo the connection and redo Step 5.

COPIER>TEST

- 6) Select the COPIER > TEST > NETWORK > PING service mode item, enter the loop back address* (127.0.0.1), and press the OK key followed by the start key.
 - If 'NG' is displayed, there is a problem with the local TCP/IP settings. Go back to Step 3 and check the settings again.
 - If 'OK' is displayed, there is no problem with the local TCP/IP settings. However, there could be a problem with the network interface board (NIC) connection or the NIC itself. Go to Step 7 to check the NIC.
- * The loop back address returns the signal in front of the NIC, enabling checking of the local TCP/IP settings.
- 7) Select the COPIER > TEST > NETWORK > PING service mode item, enter the local host address (local IP address), then press the OK key.
 - If 'NG' is displayed, there could be a problem with the NIC connection or the NIC itself. In this case, check the NIC connection or replace the NIC.
 - If 'OK' is displayed, there is no problem with the local network settings or NIC.

In this case, the problem may be with the user's network environment. Explain the situation to the system administrator, and ask them to deal with it.

12 COUNTER (counter mode)

The COPIER/COUNTER screen is shown below. The items are described starting on the next page.

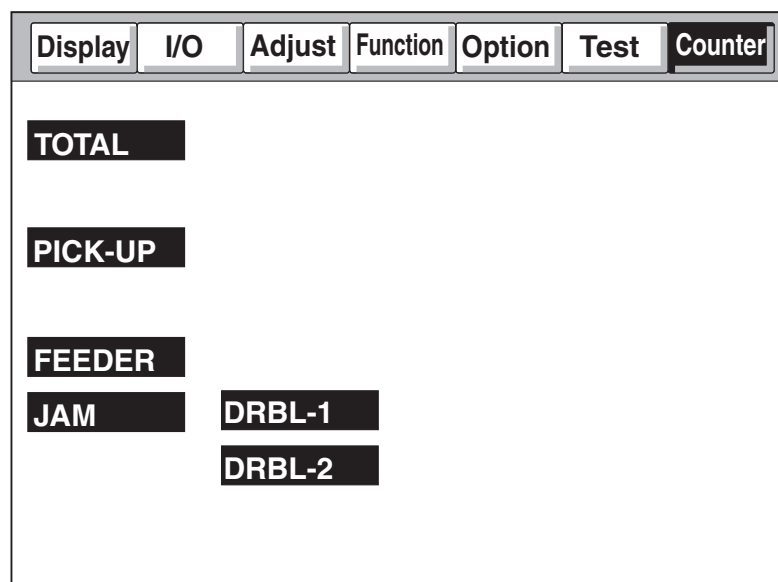

F05-1200-01

<Clearing counter values>

- 1) Select the item to clear, displaying it in reverse.
- 2) Press the clear key on the operation panel.
 - The counter is cleared, resetting it to '00000000'.

<Small size and large size in this mode>

- TOTAL/PICKUP/FEEDER/JAM
 - Large (L) size: Paper larger than A4, LTR size
 - Small (S) size: A4, LTR size and smaller paper
- DEBL-1/DEBL-2 (DF-PU-RL, DF-SP-PD, DF-F-BLT, DF-SP-RL)
 - Large (L) size: Paper longer than 324 mm in the feed direction
 - Small (S) size: Paper 324 mm or shorter in the feed direction
- DEBL-2 (items other than above)
 - Large (L) size: Paper longer than the LTR length (216 mm) in the feed direction
 - Small (S) size: Paper of the LTR length (216 mm) or shorter in the feed direction

COPIER>COUNTER

<Reading counters for consumable parts/parts needing periodic replacement>

The copier has special counters (DRBL-1/DRBL-2) that can be used to provide a guideline for when to replace consumable parts or parts needing periodic replacement.

Small size sheets are counted in increments of 1, large size sheets are counted in increments of 2.

<Example>

TR-BELT / **00000201** / **00240000** / **0%** **!!** **000082**
 [1] [2] [3] [4] [5] [6]

- [1]: Displays the part name. In this example, the intermediate transfer belt unit.
- [2]: Displays the counter value (actual number of sheets used). The value is cleared by pressing the clear key when the part is replaced.
- [3]: Displays the limit value (number of sheets as guideline for replacement). You can select the item and change the value with the numeric keypad. After changing the value, press the OK key.
- [4]: Displays the ratio of the counter value to the limit value.
- [5]: When the ratio is between 90% and 100%, a single exclamation mark (!) is displayed. When the ratio is over 100%, two exclamation marks (!!) appear. In the example above, no exclamation marks would appear.
- [6]: Displays the predicted number of days until replacement. The example above shows 82 days.

<TOTAL>

Totals counters

SERVICE1

Service total counter 1
Incremented when paper is delivered outside the printer.
(Incremented for both large and small size sheets.)
Returns to '00000000' after reaching '99999999'.

SERVICE2

Service total counter 2
Incremented when paper is delivered outside the printer.
(Incremented by 2 for large size sheets, and by 1 for small size sheets.)
Returns to '00000000' after reaching '99999999'.

COPY

Total copies counter
Incremented when a copy operation is executed and paper is delivered outside the printer.
Returns to '00000000' after reaching '99999999'.

PDL-PRT

PDL print counter
Incremented along with the billing counter during PDL printing, when paper is delivered outside the copier and two-sided paper is loaded.
Blank sheets are not counted. Incremented by 1 for both large and small size sheets.
Returns to '00000000' after reaching '99999999'.

FAX-PRT

Fax received print counter
Incremented along with the billing counter when a fax is received, when a print is delivered outside the copier and two-sided paper is loaded.
Blank sheets are not counted. Incremented by 1 for both large and small size sheets. Can be cleared.
Returns to '00000000' after reaching '99999999'.

RMT-PRT

Remote print counter
Incremented along with the billing counter when a remote print is made, when paper is delivered outside the copier and two-sided paper is loaded.
Blank sheets are not counted. Incremented by 1 for both large and small size sheets. Can be cleared.
Returns to '00000000' after reaching '99999999'.

COPIER>COUNTER

BOX-PRT

Box print counter

Incremented along with the billing counter when a box print is made, when paper is delivered outside the copier and two-sided paper is loaded.

Blank sheets are not counted. Incremented by 1 for both large and small size sheets. Can be cleared.

Returns to '00000000' after reaching '99999999'.

RPT-PRT

Report print counter

Incremented along with the billing counter when a report print is made, when paper is delivered outside the copier and two-sided paper is loaded.

Blank sheets are not counted. Incremented by 1 for both large and small size sheets. Can be cleared.

Returns to '00000000' after reaching '99999999'.

2-SIDE

Two-sided copy/print counter

Incremented along with the billing counter when a two-sided copy/print is made, when paper is delivered outside the copier and two-sided paper is loaded.

Blank sheets are not counted. Incremented by 1 for both large and small size sheets. Can be cleared.

Returns to '00000000' after reaching '99999999'.

SCAN

Scan counter

Incremented along with the billing counter when a scan is made, when reading finishes.

Incremented by 1 for both large and small size sheets. Can be cleared.

Returns to '00000000' after reaching '99999999'.

<PICKUP>

Paper feed counters

C1

Cassette 1 paper feed total counter
Displays number of sheets fed from cassette 1.
Returns to '00000000' after reaching '99999999'.

C2

Cassette 2 paper feed total counter
Displays number of sheets fed from cassette 2.
Returns to '00000000' after reaching '99999999'.

C3

Cassette 3 paper feed total counter
Displays number of sheets fed from cassette 3 (top level of cassette pedestal).
Returns to '00000000' after reaching '99999999'.

C4

Cassette 4 paper feed total counter
Displays number of sheets fed from cassette 4 (bottom level of cassette pedestal).
Returns to '00000000' after reaching '99999999'.

MF

Manual paper feed total counter
Displays number of sheets fed from manual paper feed unit.
Returns to '00000000' after reaching '99999999'.

DK

Deck paper feed total counter
Displays number of sheets fed from deck paper feed unit.
Returns to '00000000' after reaching '99999999'.

2-SIDE

Two-sided paper feed total counter
Displays number of two-sided sheets fed.
Returns to '00000000' after reaching '99999999'.

COPIER>COUNTER

<JAM>

Jam counters

TOTAL

Total jam counter for copier

FEEDER

Total jam counter for feeder

SORTER

Total jam counter for finisher

2-SIDE

Jam counter for two-sided unit

MF

Jam counter for multi-feeder

C1

Jam counter for cassette 1

C2

Jam counter for cassette 2

C3

Jam counter for cassette 3

C4

Jam counter for cassette 4

DK

Jam counter for side paper deck

<DRBL-1>

Counters indicating frequency of use of copier consumable parts

SCN-LMP

Number of sheets document illumination lamp has lit (count value is stored in controller).

T-CLN-BD

Number of sheets that have passed through transfer cleaning unit (count value is stored in controller).

TR-BLT

Number of sheets that have passed through intermediate transfer belt unit (count value is stored in controller).

TR-ROLL

Number of sheets that have passed through secondary transfer outer roller (count value is stored in controller).

C1-PU-RL

Number of sheets that have passed through cassette 1 paper feed roller (count value is stored in controller).

C2-PU-RL

Number of sheets that have passed through cassette 2 paper feed roller (count value is stored in controller).

M-PU-RL

Number of sheets that have passed through manual paper feed roller (count value is stored in controller).

FX-UP-RL

Number of sheets that have passed through fixing roller (count value is stored in controller).

FX-LW-RL

Number of sheets that have passed through pressure roller (count value is stored in controller).

FX-UNIT

Number of sheets that have passed through fixing unit (count value is stored in controller).

FX-UP-FR

Number of sheets that have passed through fixing upper frame unit (count value is stored in controller).

COPIER>COUNTER

<FEEDER>

DADF counter

FEED

ADF document feed total counter

<DRBL-2>

Counters indicating frequency of use of optional consumable parts

DF-PU-RL

Number of sheets that have passed through ADF paper feed roller.

DF-SP-PD

Number of sheets that have passed through ADF separation pad.

DF-F-BLT

Number of sheets that have passed through ADF conveyor belt.
Incremented by 3 for S-size two-sided sheets, and L-size one-sided/two-sided sheets.

DF-SP-RL

Number of sheets that have passed through ADF separation roller.

PD-PU-RL

Number of sheets that have passed through paper deck paper feed roller.

C3-PU-RL

Number of sheets that have passed through cassette 3 paper feed roller.

C4-PU-RL

Number of sheets that have passed through cassette 4 paper feed roller.

SORT

Number of sheets that have passed through sort path.
Incremented by 1 even for L-size sheets.

FIN-STPR

Number of staple operations.

FIN-PDDL

Number of sheets that have passed through finisher paddle.
Incremented by 1 even for L-size sheets.

SADDLE

Number of saddle operations.
Incremented by 1 even for L-size sheets.

SDL-STPL

Number of saddle staple operations.
Incremented by 1 even for L-size sheets.

CHAPTER 6

UPGRADING

1 Outline of Upgrading Work

1.1 Outline

1.1.1 Composition of Firmware

The construction of the machine's firmware is as follows:

Firmware	Function	Location	Remarks
System	Control of the system as a whole	HDD	
Language	Display of control panel screens	HDD	
RUI	Display of the RUI	HDD	
Boot	Startup of the machine	BootROM	DIMM
G3FAX	Control of the G3 FAX Board	G3 FAX Board	DIMM
Dcon	Control of DC controller	DC controller PCB	Soldered to a flash ROM
Rcon	Control of the reader controller	Reader controller PCB	Soldered to a flash ROM

T06-101-01

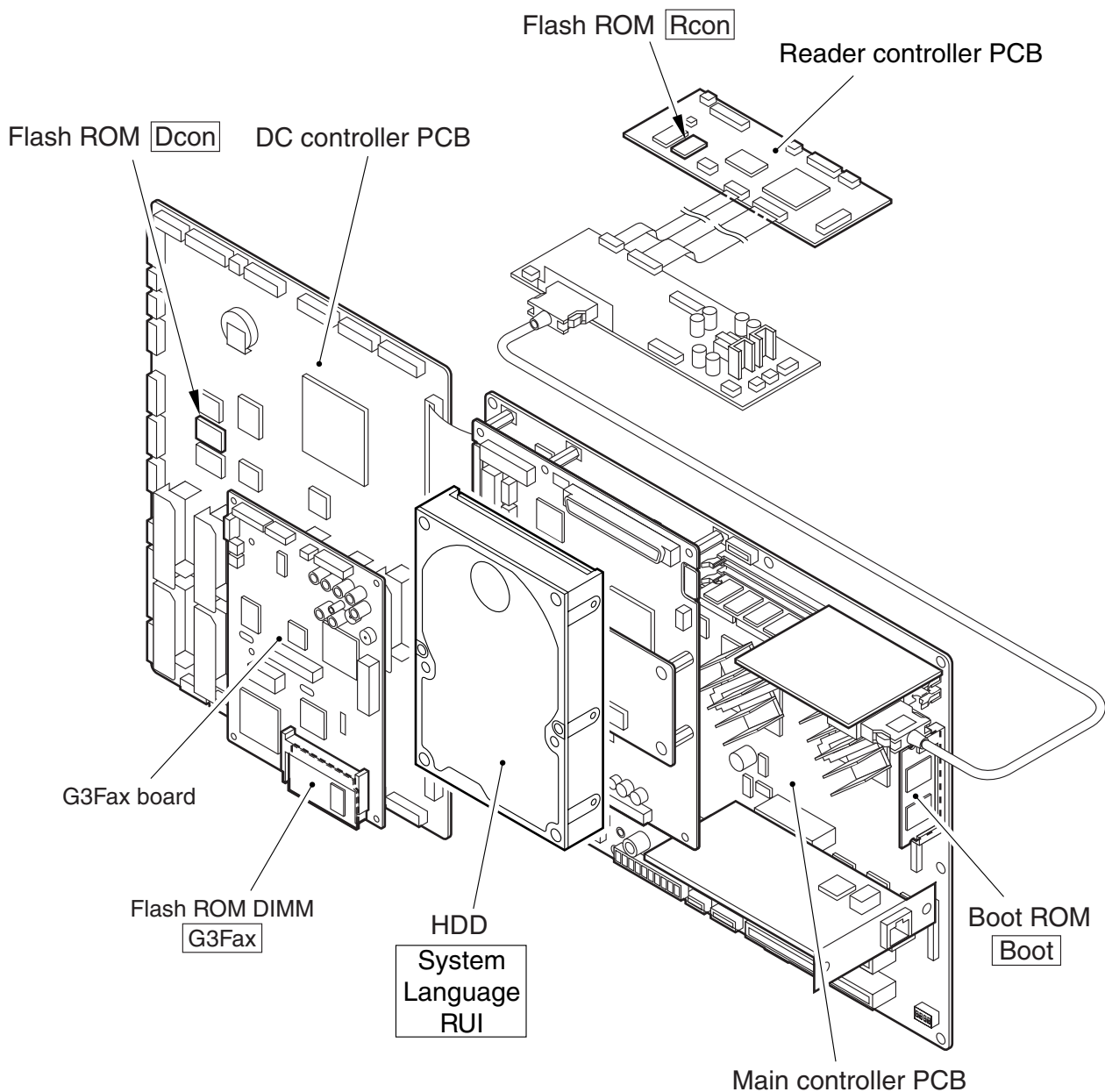

F06-101-01

1.1.2 Outline of the Service Support Tool

The service support tool (SST, hereafter) provides the following functions:

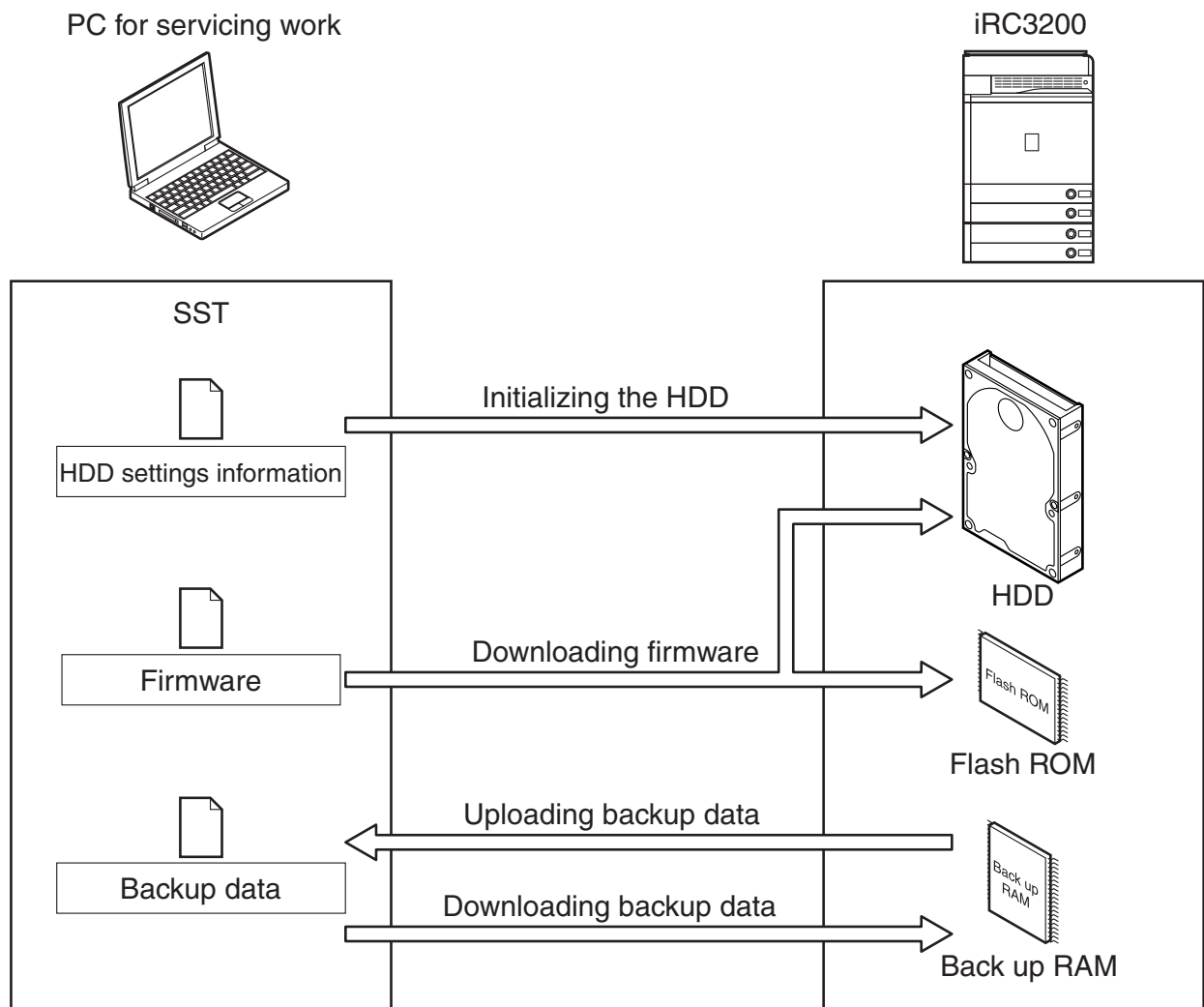

F06-101-02

To use the SST, you must first set the machine to download mode. The machine's download mode consists of 2 types, selected by pressing a combination of appropriate keys (keypad) when starting up the machine.

[1] normal mode: 1 + 7

after startup, start service mode, and make the following selections:

COPIER>Function>SYSTEM>DOWNLOAD

[2] safe mode: 2 + 8

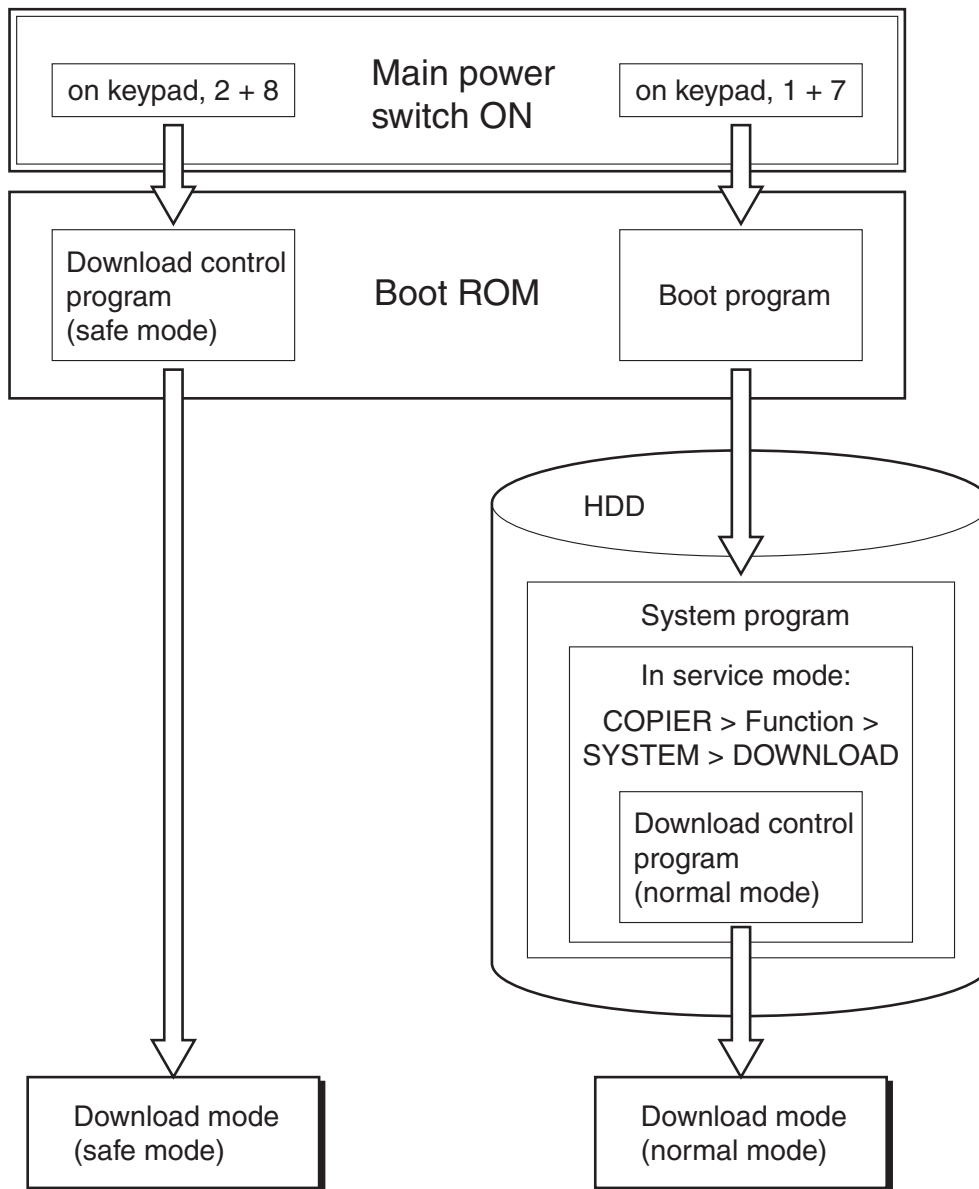

F06-101-03



Use safe mode for the following:

- after replacing the HDD.
- if the system fails to operate normally (E602-0001, -0002).

The following shows combinations of functions that may be used in association with the SST and the machine when the machine is in download mode:

Function	Download mode	
	Normal mode	Safe mode
Formatting the HDD		All inclusive BOOTDEV
	DOSDEV FSTDEV DOSDEV2 FSTPDEV DOSDEV3 PDLDEV DOSDEV4 DOSDEV5	
Downloading firmware	<ul style="list-style-type: none"> • System • Language • RUI • Boot • G3Fax • Dcon • Rcon 	<ul style="list-style-type: none"> • System • Language • RUI • Boot
Uploading backup data	<ul style="list-style-type: none"> • SramImg • SramDCON • SramRCON 	<ul style="list-style-type: none"> • SramImg
Downloading backup data	<ul style="list-style-type: none"> • SramImg • SramDCON • SramRCON 	<ul style="list-style-type: none"> • SramImg

T06-101-02

1.1.3 Network Interface of the Machine with the SST in Use

The machine communicates with the SST using the Ethernet protocol (TCP/IP). The machine offers the following 2 sets of network settings:

- user environment network settings (user mode>system control settings>network settings)

- service network settings (IP address: 172.16.1.100; subnet mask: 255.255.255.0, fixed)

The network settings are dependent on how the machine is started up.

The user environment settings are retained while the service settings are selected.

You need not change the user mode network settings before or after the use of the SST.

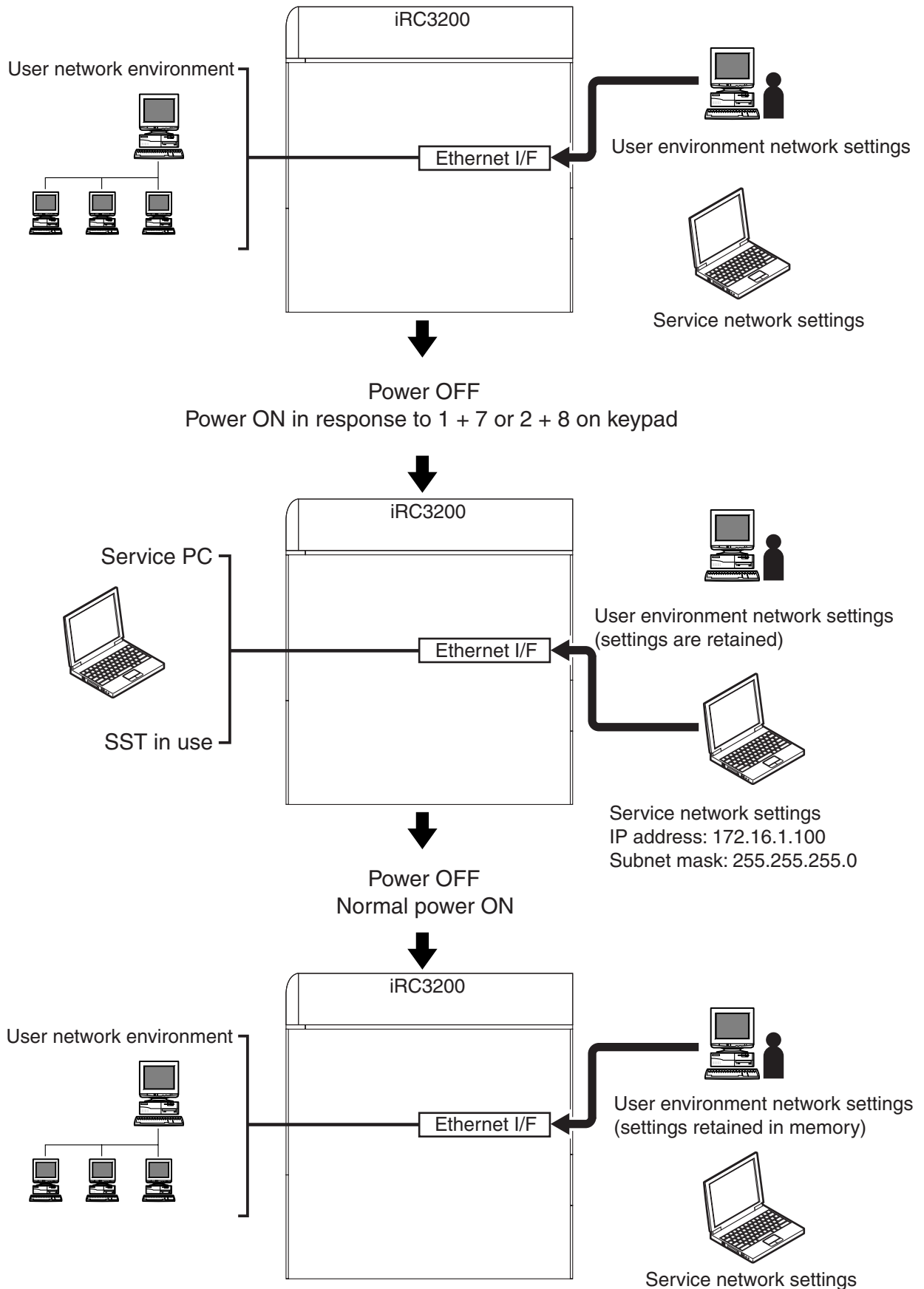

F06-101-04

If you start up the machine by pressing 1 + 7, the machine indicates 'FIXIP' in the upper right of the LCD to distinguish its state from normal.

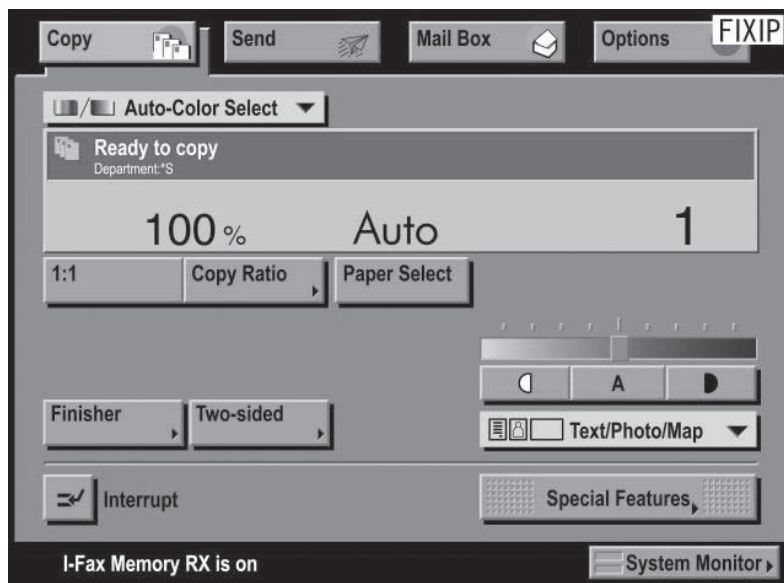

F06-101-05

If a TokenRing board is installed, the Ethernet interface is disabled. If you, on the other hand, start up the machine by pressing 1 + 7 or 2 + 8, the TokenRing interface will be disabled while the Ethernet interface remains enabled; thus, you need not remove the TokenRing board when connecting the SST.

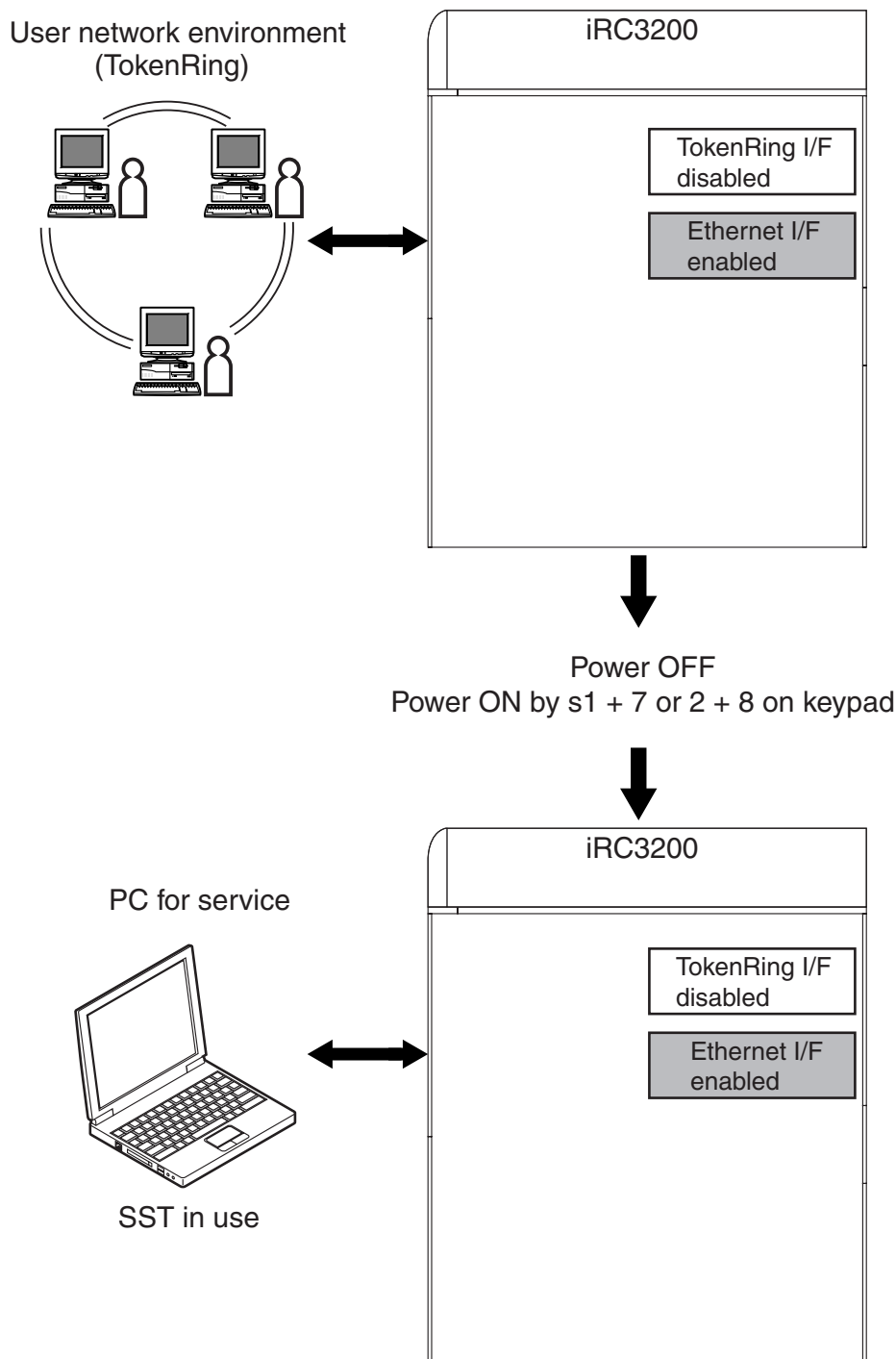

F06-101-06

1.2 Preparing for the Work

1.2.1 Registering the Firmware

You will be registering the firmware stored on the system CD to the SST.

Before Starting the Work

Keep the following on hand:

- PC to which SST v1.61 or later has been installed.
- system CD for iRC3200

Registering the Firmware

- 1) Start up the PC.
- 2) Set the system CD to the PC.
- 3) Start up the SST.
- 4) Click 'next' under 'data management'.

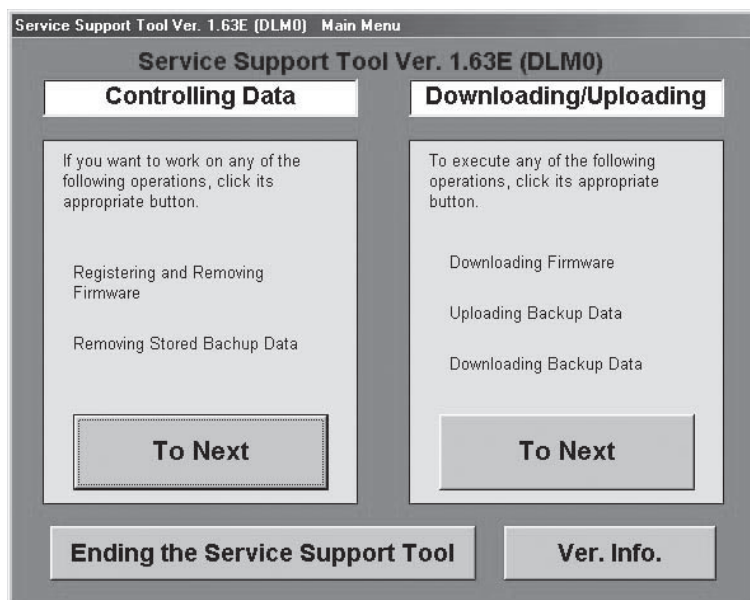

F06-102-01

5) Click 'Registering Firmware'.

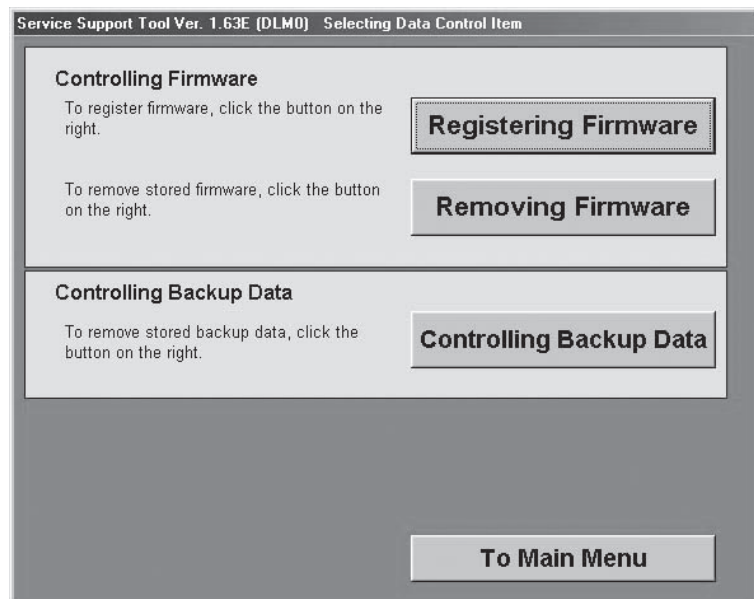

F06-102-02

6) Click 'register from selected folder'.

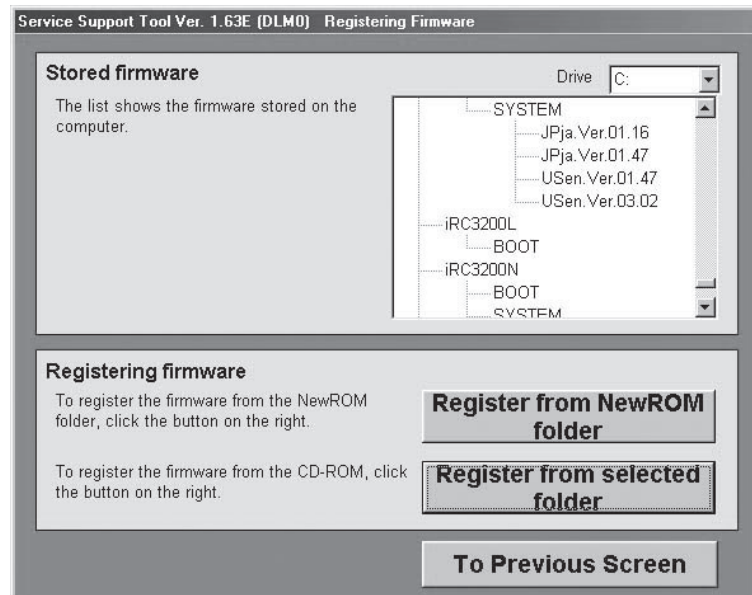

F06-102-03

7) Select the drive in which you have set the system CD, and click 'Search'.

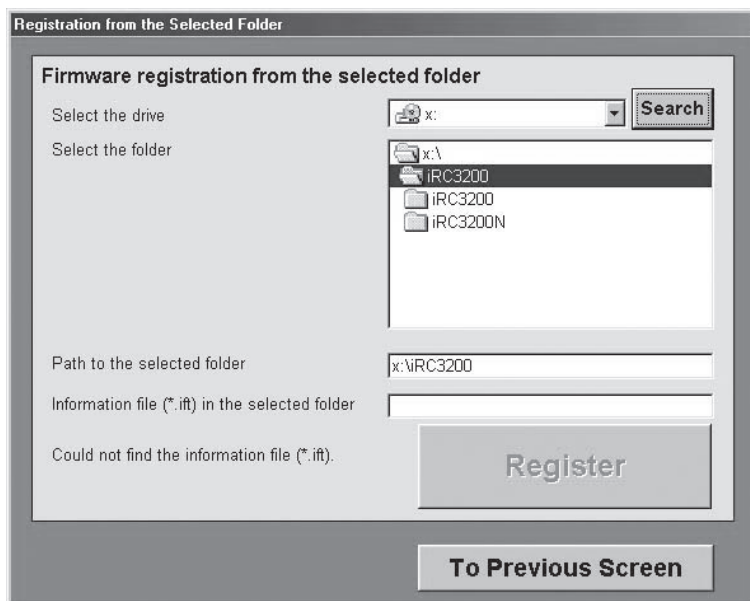

F06-102-04

8) When the list of firmware items contained on the system CD has appeared, click 'Register All' after it becomes enabled.

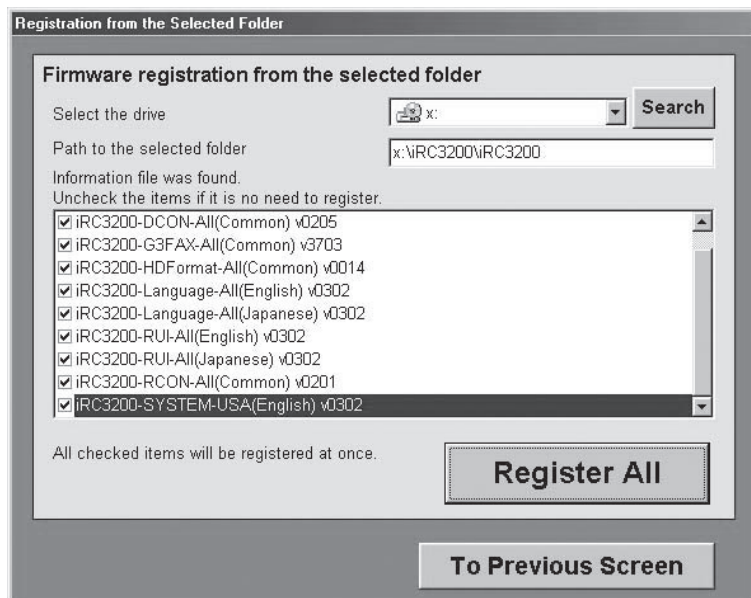

F06-102-05

9) When the results of the registration have appeared, press 'OK'.

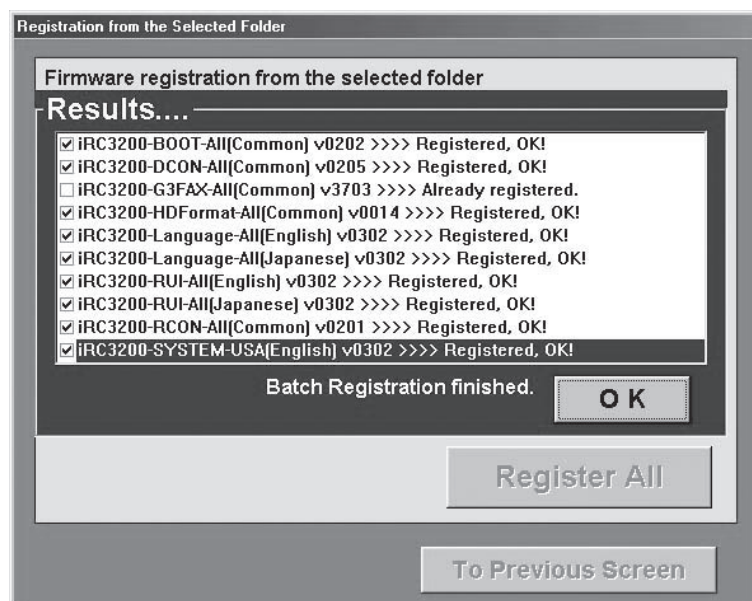

F06-102-06

1.2.2 Making Connections

You will be connecting the PC to the machine.

Before Starting the Work

Keep the following on hand:

- PC to which SST v1.61 or later has been installed and iRC3200 firmware has been registered
- Twisted pair 10Base-T (category 3 or 5)
Cross cable 100Base-TX (category 5)

Procedure

1) Start up the PC.

2) Check the network settings of the PC.

Type 'IPCONFIG' in response to the command prompt, and press the Return key. Check to see that the network settings are as follows:

IP address: 172.16.1.10 (other than 172.16.1.0, 172.16.1.100, 172.16.1.255)

Subnet mask: 255.255.255.0

Default gateway: any

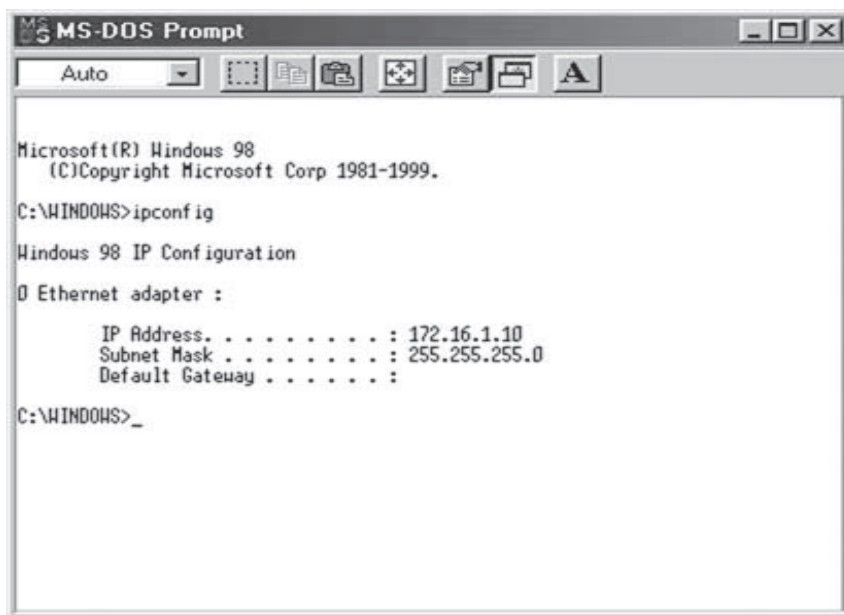

F06-102-07

If the settings are not as indicated, change the PC network settings:

- 3) Check to see that the Execute/Memory lamp on the control panel is OFF; then, turn off the machine's main power switch.
- 4) Connect the machine and the PC with a cross cable.

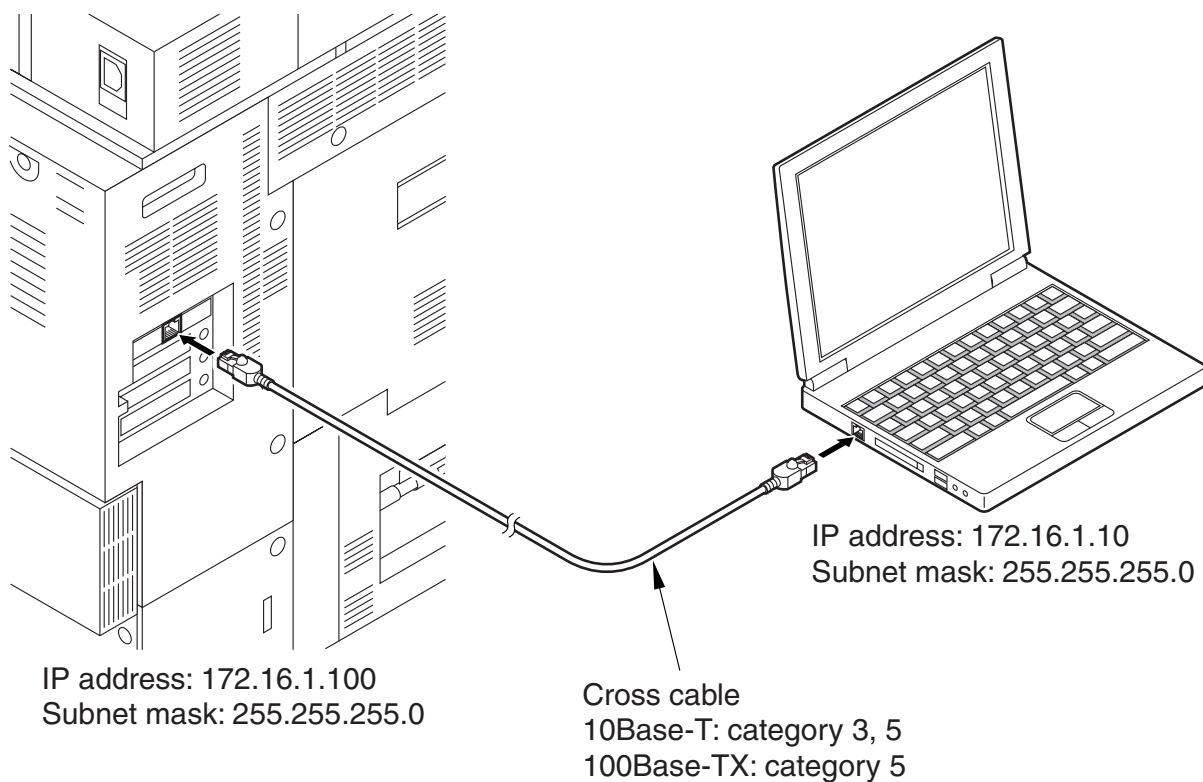

F06-102-08

- 5) While holding down the keys (keypad) suited to the download mode you are going to use, turn on the machine's main power switch.
 - if normal mode, 1 + 7
enter source mode, and make the following selections:
COPIER>Function>SYSTEM>DOWNLOAD
 - if safe mode, 2 + 8
- 6) Start up the SST.

7) Click 'next' under 'Download/Upload'.

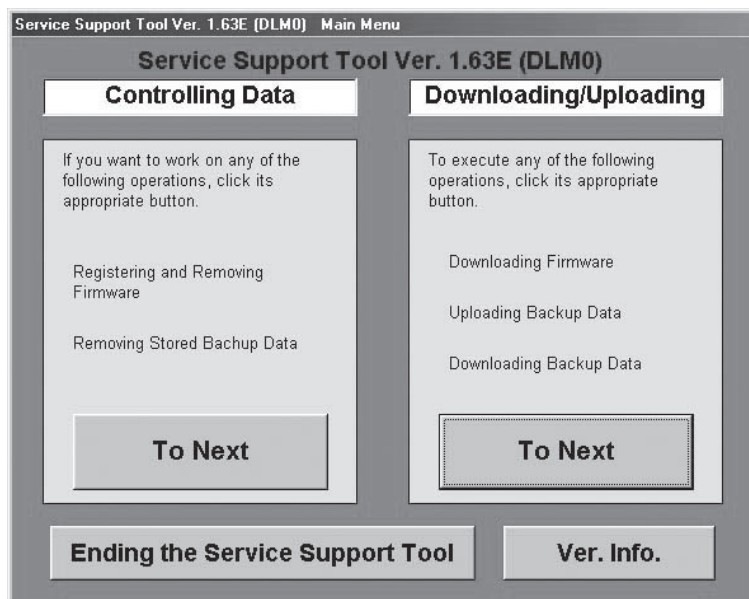

F06-102-09

8) Select the model of the machine.

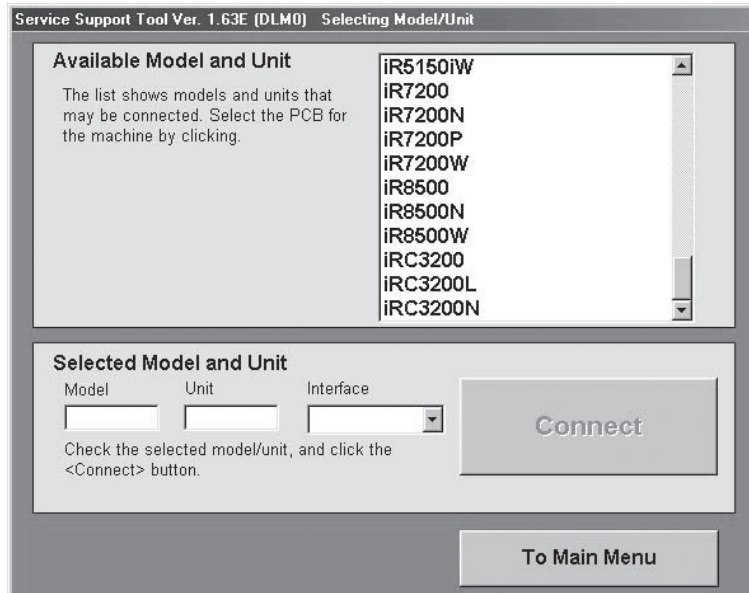

F06-102-10

9) Select the unit you want, and click 'Connect'.

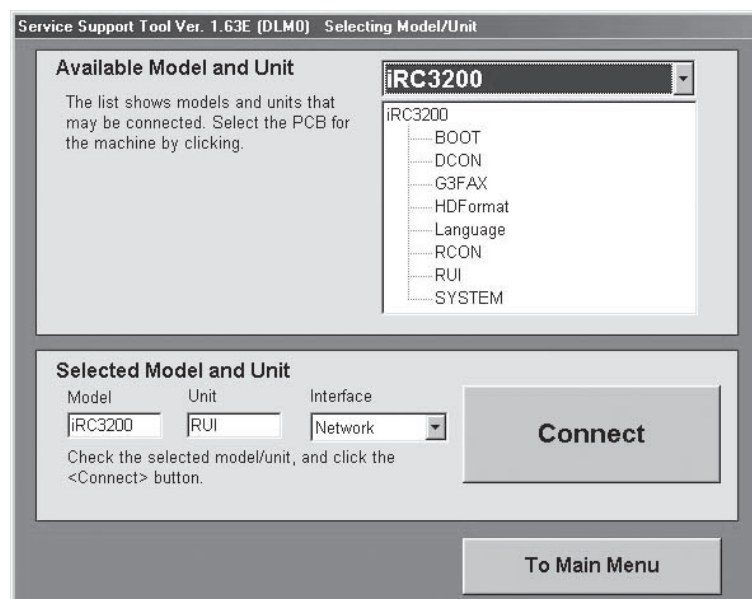

F06-102-11

10) Click 'Set host name'.

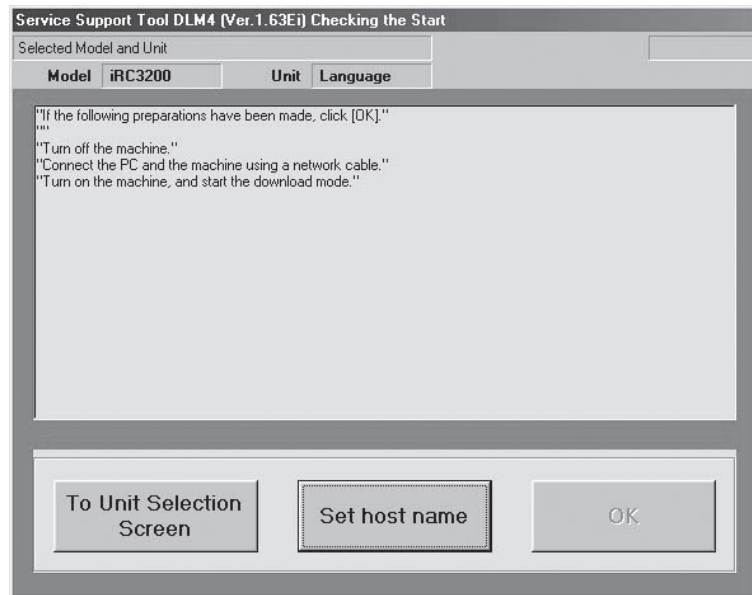

F06-102-12

11) The machine's IP address is entered automatically; click 'OK'.

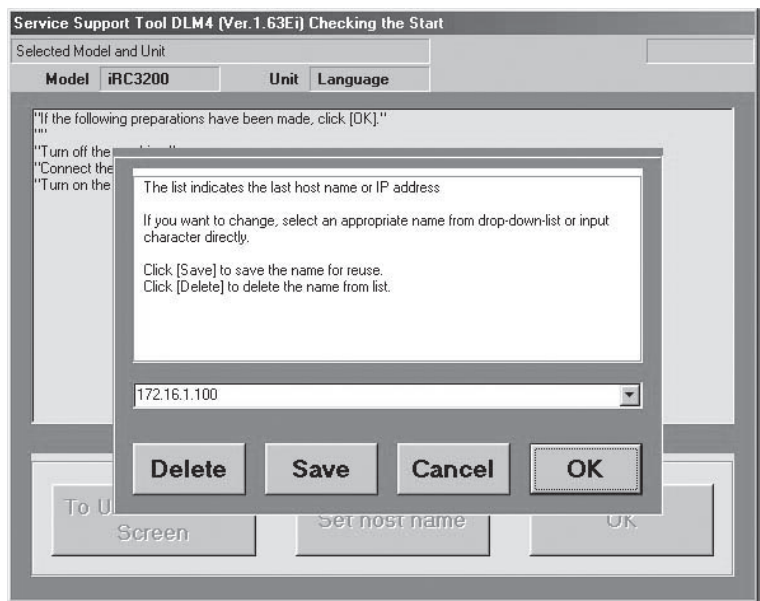

F06-102-13

12) Click 'OK' so that the machine makes a connection.

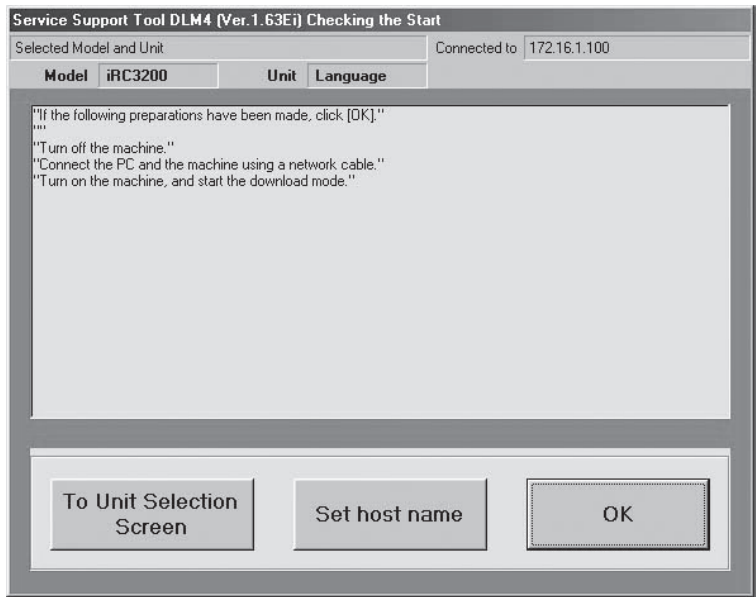

F06-102-14

- 13) When the machine has made a connection and brings up the following screen, click 'OK'.

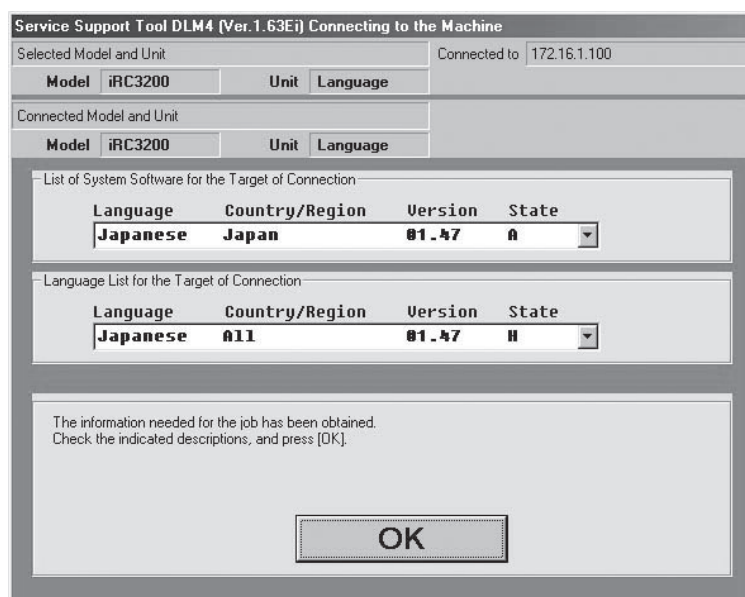

F06-102-15

2 Formatting the HDD

2.1 Formatting All Partitions

You will be setting up partitions on the HDD and formatting (initializing) them for use by the main controller.

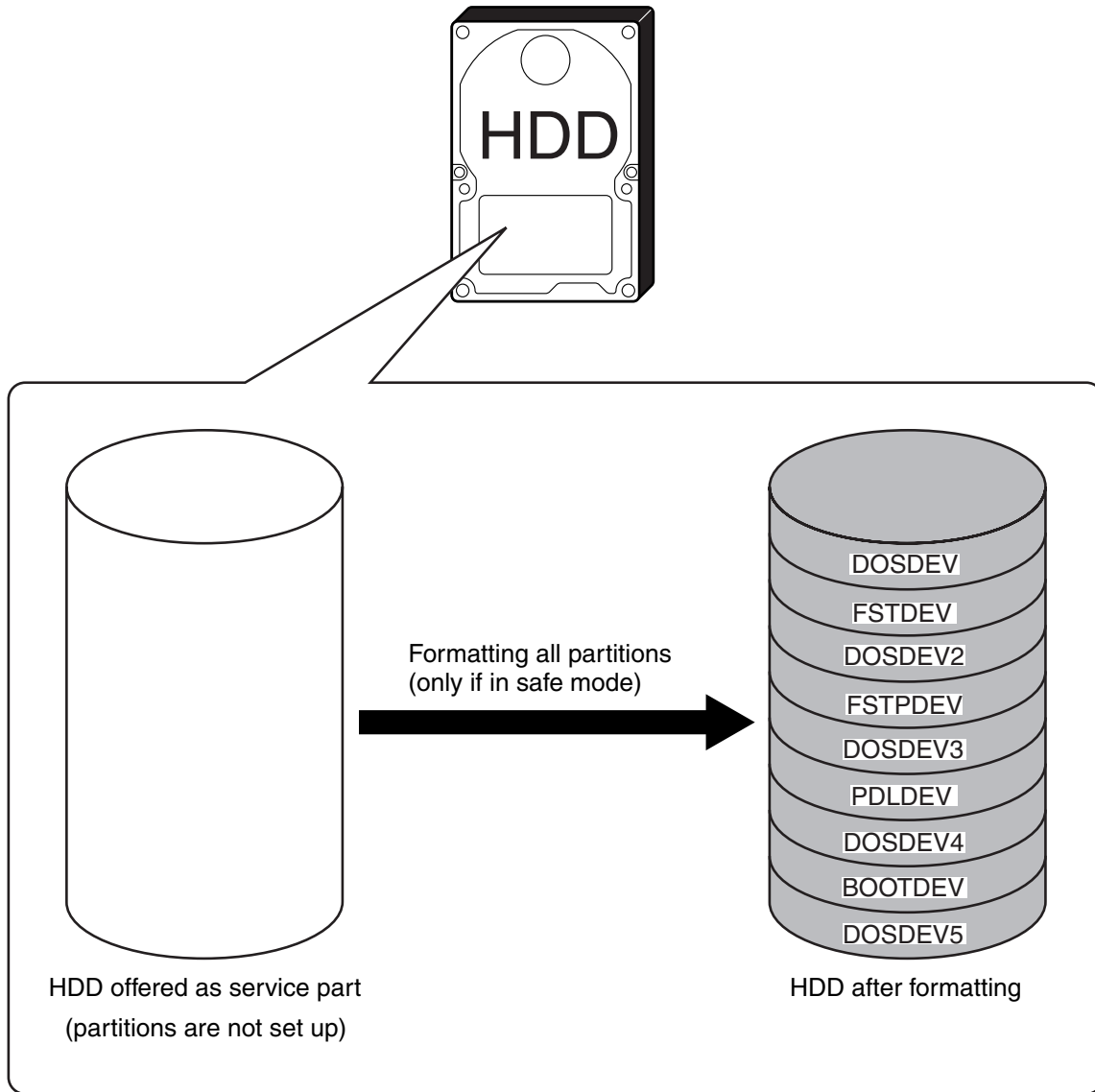

F06-201-01



E602-0001

- Indicates that the BOOTDEV partition, in which the system programs are stored, cannot be found at time of start-up.
- To correct, format all partitions in safe mode, and download the following: system, language, RUI.

2.2 Formatting Selected Partitions

You will be formatting (initializing) partitions that you have selected.

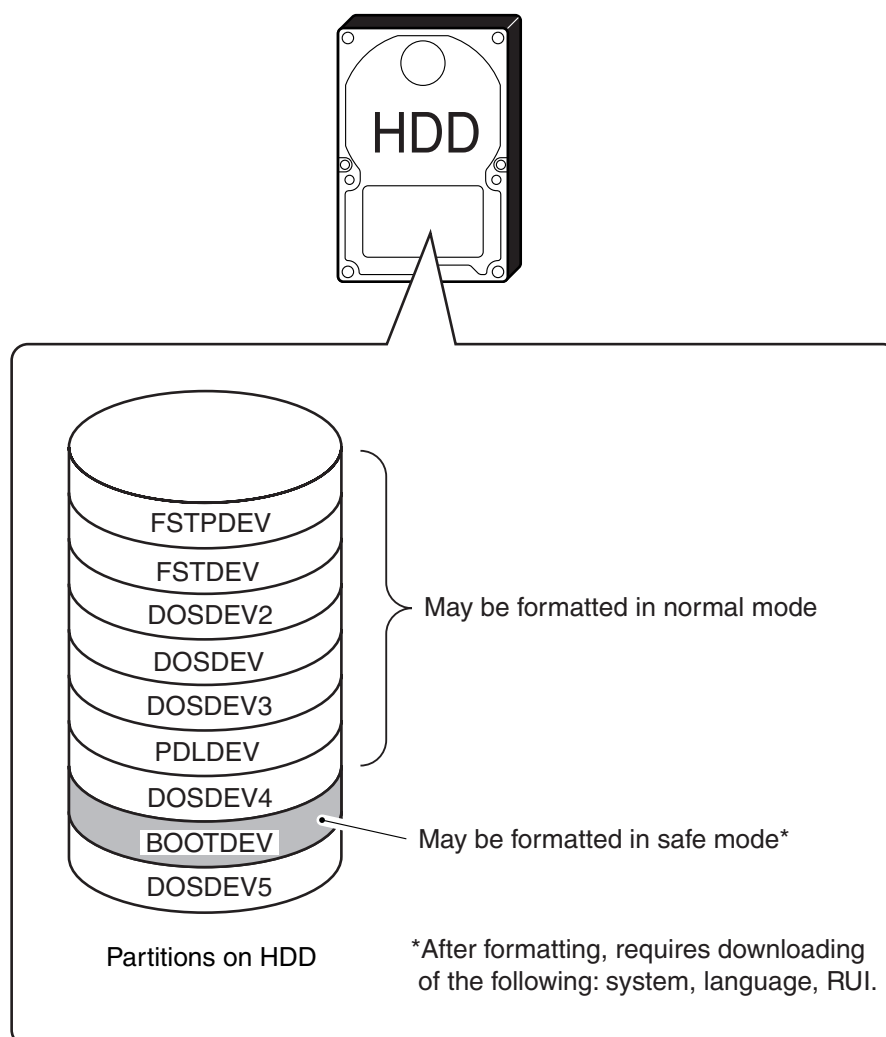

F06-202-01

Partition	Description	Error code for data error
DOSDEV	Area for general work	E602-0401
FSTDEV	Storage of image data	E602-0201
DOSDEV2	Storage of thumbnail display data of image data	E602-0301
FSTPDEV	Storage of image data	E602-0101
DOSDEV3	Temporary storage of PDL job	E602-0501
PDLDEV	PDL processing	E602-0601
DOSDEV4	Storage of address book, filter	E602-0701
BOOTDEV	System area (stores system, language, RUI)	E602-0801
DOSDEV5	Reserved	E602-0901



E602-0x01

- Indicates the presence of a data error in the identified partition.
 - To correct, format the identified partition.
-

Formatting Partitions Using the SST

Name of partition that may be selected by the SST	Partition that is formatted
FSTDEV	FSTDEV, FSTPDEV, DOSDEV, DOSDEV2
DOSDEV3	DOSDEV3
PDLDEV	PDLDEV
DOSDEV4	DOSDEV4
DOSDEV5	DOSDEV5
BOOTDEV	BOOTDEV

FSTDEV and FSTPDEV retain image data as it accumulates while DOSDEV and DOSDEV2 retain its associated data; these 4 partitions, therefore, must be formatted at the same time. To do so, select FSTDEV using the SST.

The actual formatting of FSTDEV and PDLDEV takes place when the machine is started up the next time, and it takes as long as the following:

- FSTDEV: 2 min (approx.)
- PDLDEV: 5 min (approx.)
- all partitions: 7 min (approx.; i.e., FSTDEV + PDLDEV)

The times vary according to the state of the HDD, and the progress of formatting is indicated by means of a progress bar.

Formatting of DOSDEV4 requires the use of the SST.

2.3 Formatting the Partitions

- 1) Click 'To Next' under 'Download/Upload'.

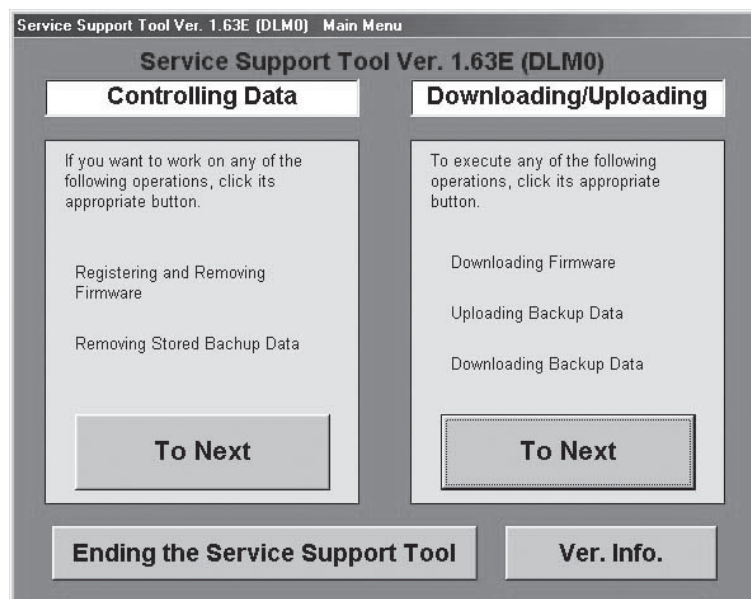

F06-203-01

- 2) Select HD Format, and click 'Connect'.

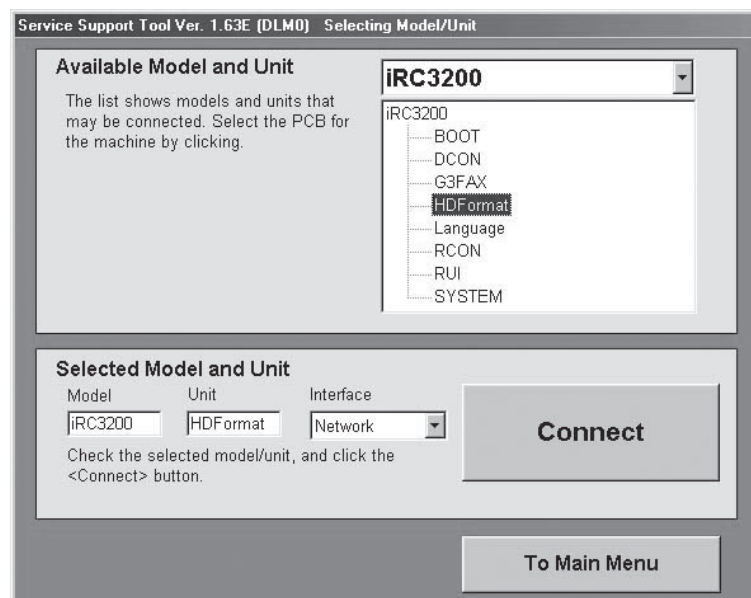

F06-203-02

3) Click 'Set host name'.

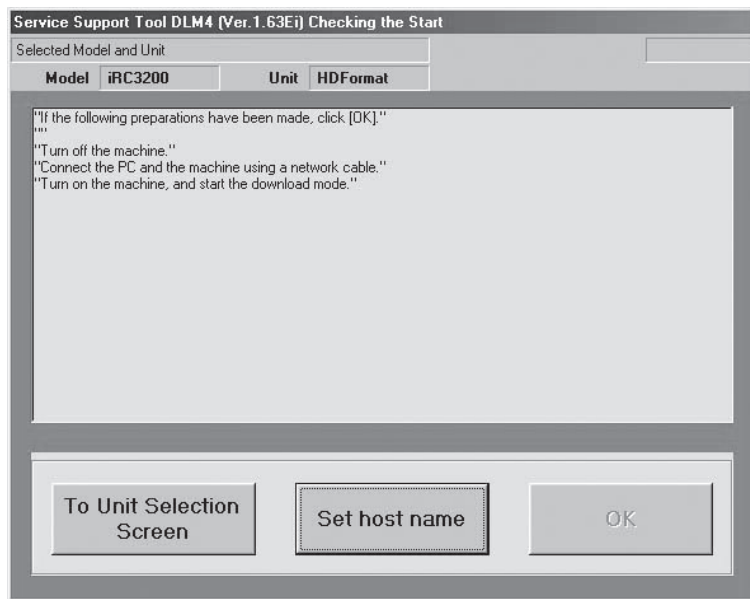

F06-203-03

4) The machine's IP address is entered automatically; click 'OK'.

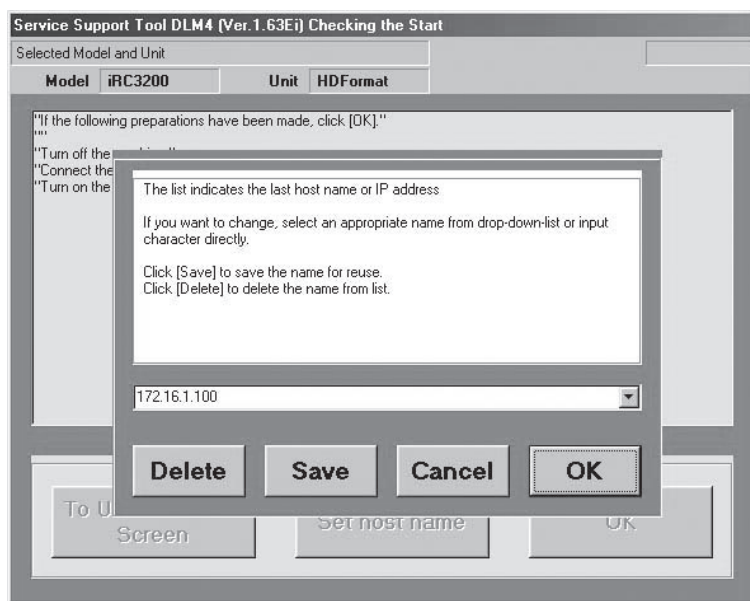

F06-203-04

- 5) Click 'OK' to start connection.

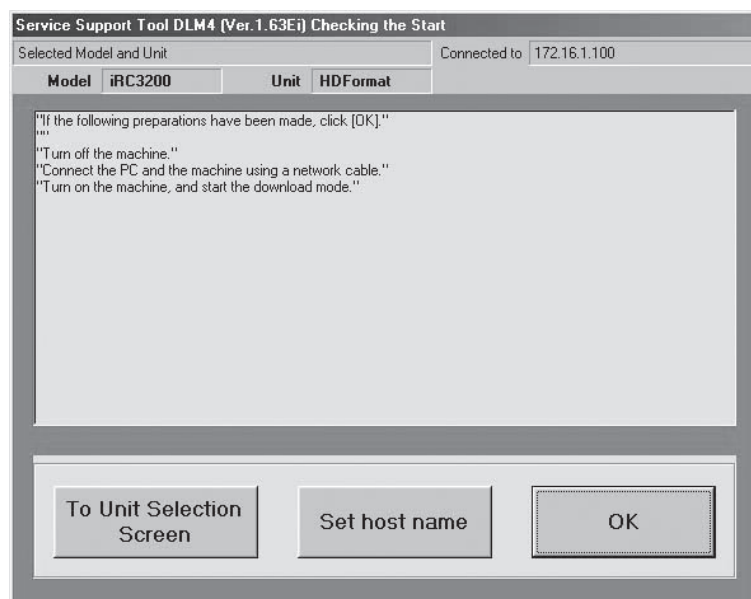

F06-203-05

- 6) When the machine has made a connection and brings up the following screen, click 'OK'.

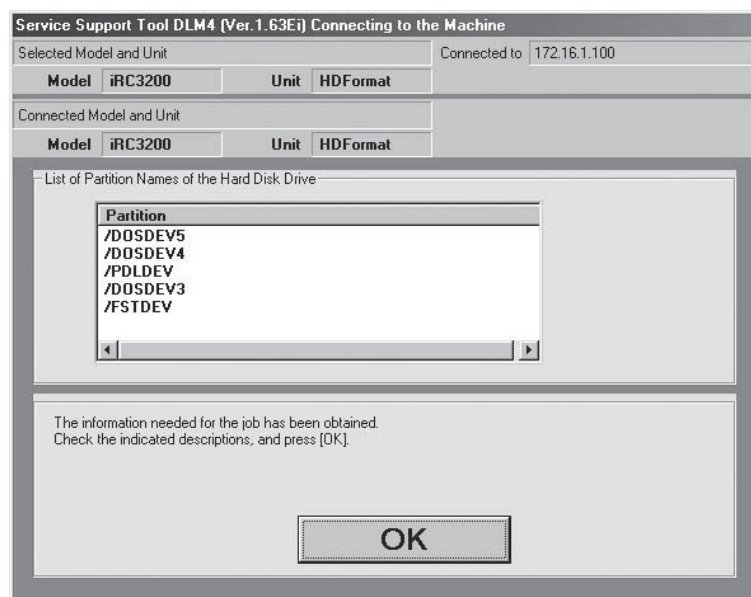

F06-203-06

7) Click 'Format'.

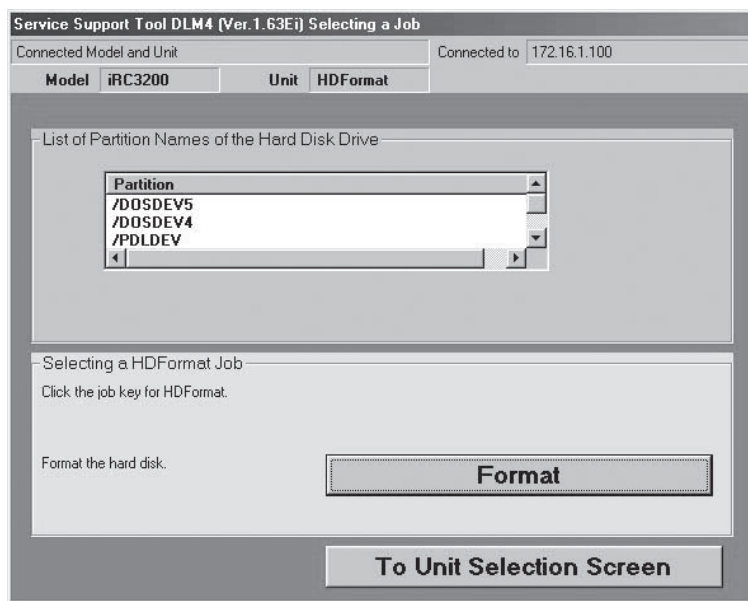

F06-203-07

8) Select the partition you want to format from the list, and click 'Start'.
To format all partitions, click 'start' shown for all partitions (enabled if in safe mode).

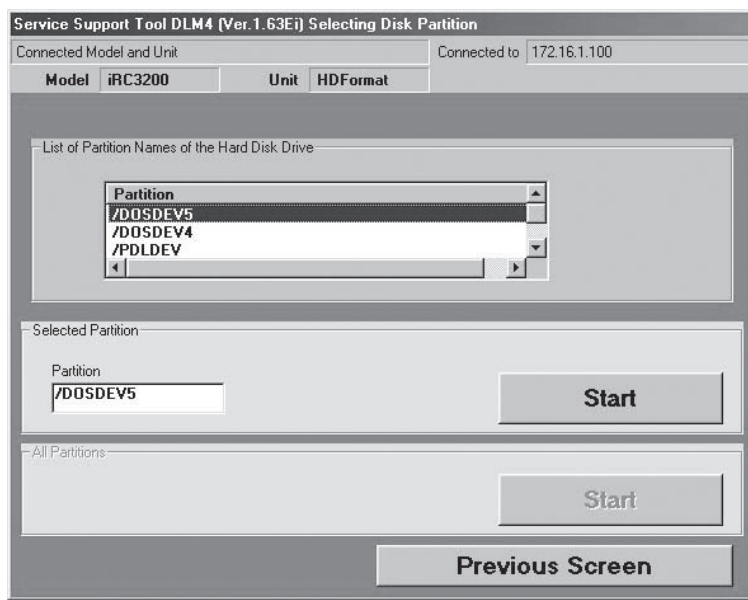

Normal mode
F06-203-08

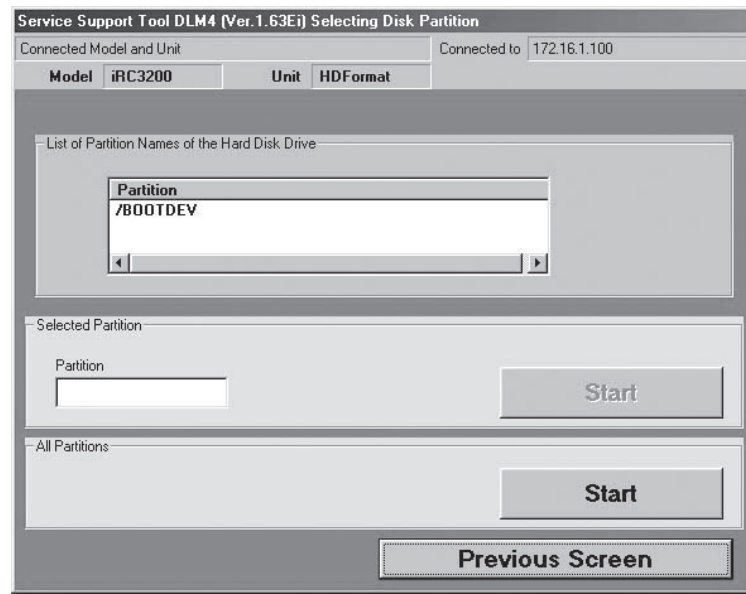

Safe mode
F06-203-09

- 9) When the machine indicates the message for confirmation for the last time, click 'Start'.

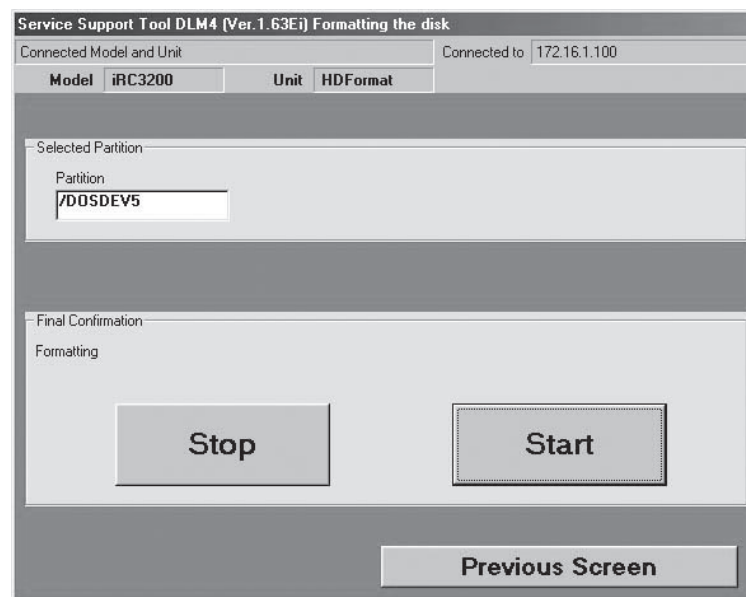

F06-203-10

10) When the machine indicates the message to indicate the end of formatting, click 'OK'.

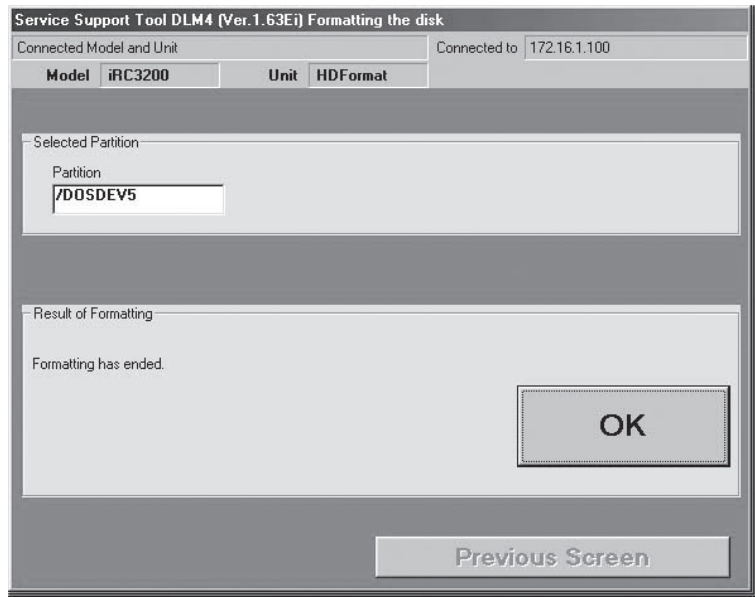

F06-203-11

11) Click 'return to unit selection screen'.



If you have formatted all partitions or BOOTDEV, you must download the following: system, language, RUI. If you fail to download system, an error (E602-0002) will occur when the main power is turned on.

Formatting of PDLDEV and DOSDEV2 takes place when the main power is turned on the next time.

Although varying according to the state of the HDD, formatting lasts as long as the following: for all partitions, about 7 min; for PDLDEV, about 5 min; for DOSDEV2, about 2 min. The progress bar indicated at time of power-on will advance gradually while formatting is taking place. Turning off the power at this time prevents access to the HDD, causing E0602. You must not turn off the machine's main power while the progress bar is shown.

3 Downloading Firmware

3.1 Downloading the System Software

3.1.1 Outline

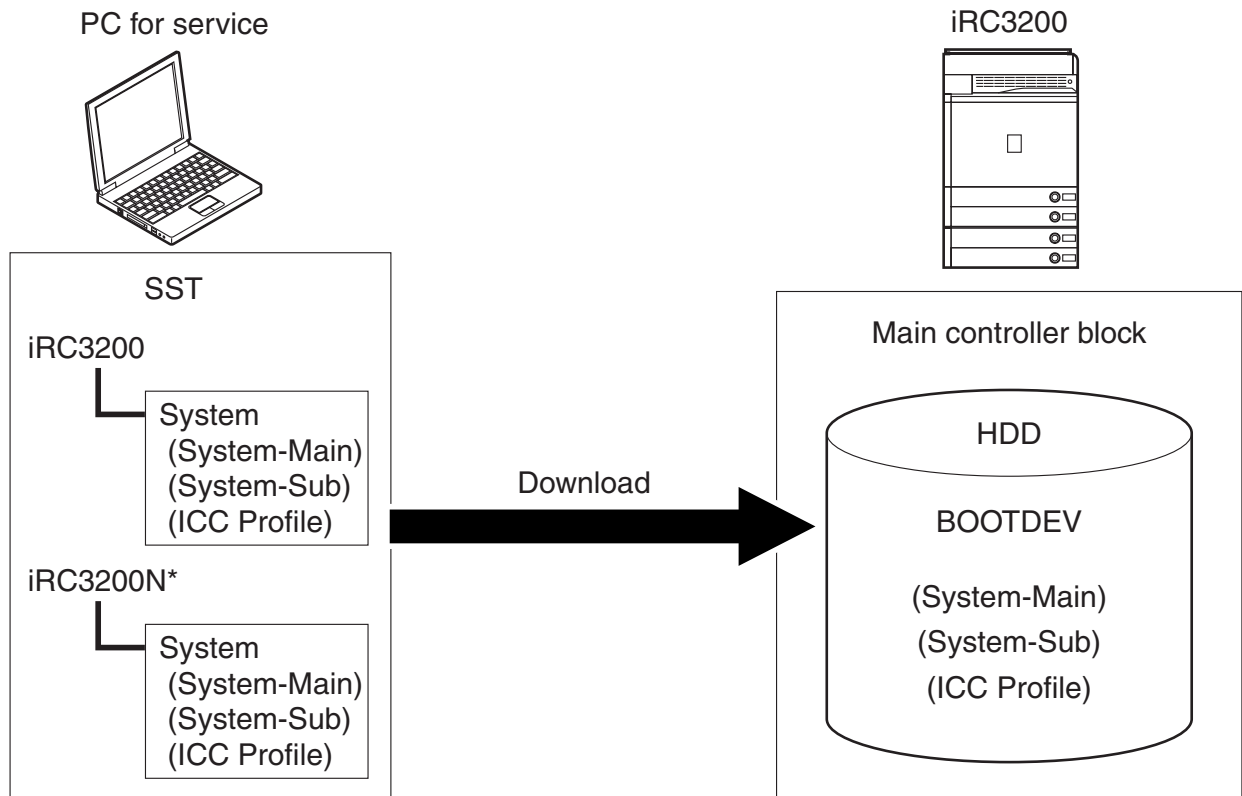

*Only for Japan.

F06-301-01

The system software comes in 3 types, selected depending on the country of installation and support of NetWare. In the case of Japan, an appropriate model must be selected with reference to the presence/absence of support for NetWare.

Country	SST installation model	Firmware	NetWare	Remarks
Japan	iRC3200	System-JP ja	Not supported	Installed at time of shipment (to iRC3200/3200S)
	iRC3200N	System-JP ja	Supported	Installed at time of shipment (to iRC3200N)
Other	iRC3200	System-USen	Supported	Installed at time of shipment

The machines' firmware consists of multiple files. The SST handles these files in groups, and transfers them in succession at time of downloading.

Files Making Up the System Software

Notation	Description
System-Main	program for main CPU
System-Sub	program for sub CPU
ICC Profile	color correction information file for PDL functions



E602-0002

- the system software for the main CPU cannot be found when the machine is started up.
- to correct, download the system software.

E602-0006

- the system file cannot be found for the sub CPU when the machine is started up.
- to correct, download the system software.

E602-0007

- the IC profile cannot be found when the machine is started up.
- to correct, download the system software.

3.1.2 Downloading Procedure

Making Checks in Advance (only in Japan)

Check the type of system software installed to the machine (support of NetWare) in service mode.

COPIER>Display>ACC-STIS>NETWARE

NetWare not supported: 0

NetWare Supported: 1

Select the type of system software to download using the name of the model:

iRC3200

System-JP ja (for Japan): NetWare not supported

iRC3200N

System-JP ja (for Japan): NetWare supported

Procedure

Download Mode

if E602-0002 is indicated, safe mode

otherwise, normal mode

- 1) Click [To Next] under 'Download/Upload'.

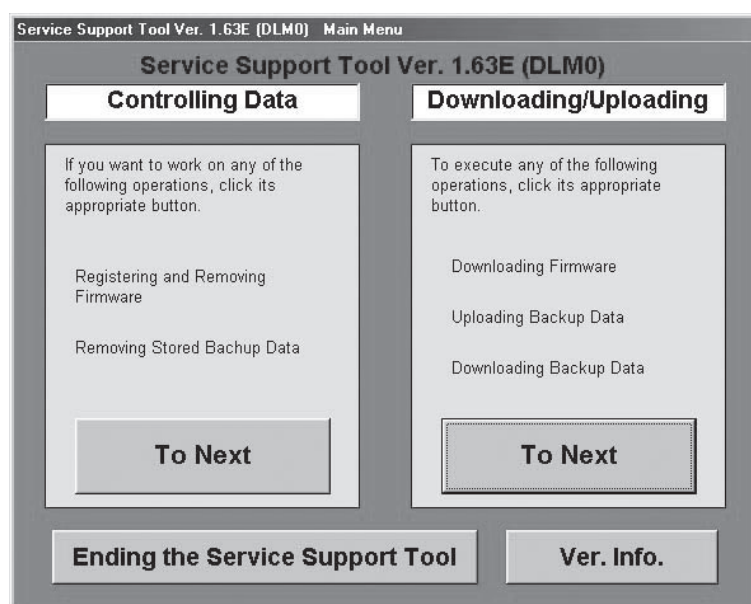

F06-301-02

- 2) Select the system software of the iRC3200, and click [Connect].
 In Japan and if NetWare is supported, be sure to select the system software of the iRC3200N.

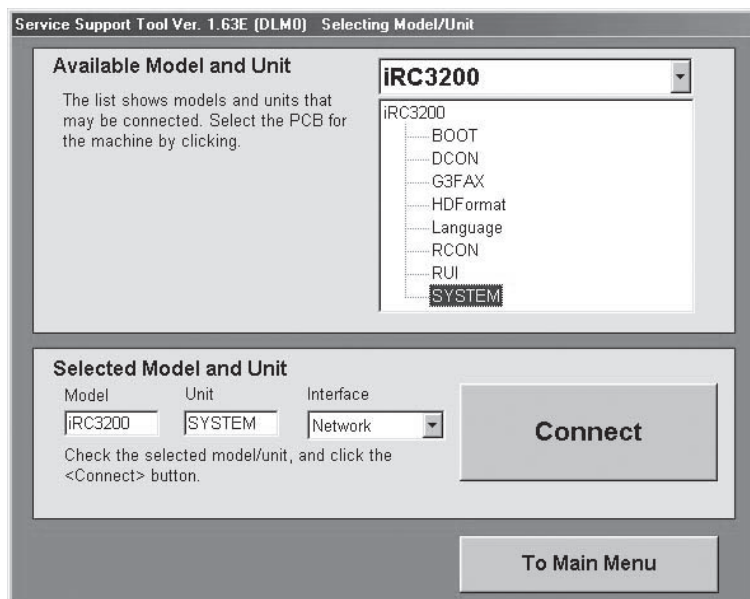

F06-301-03

- 3) Click [Set host name].

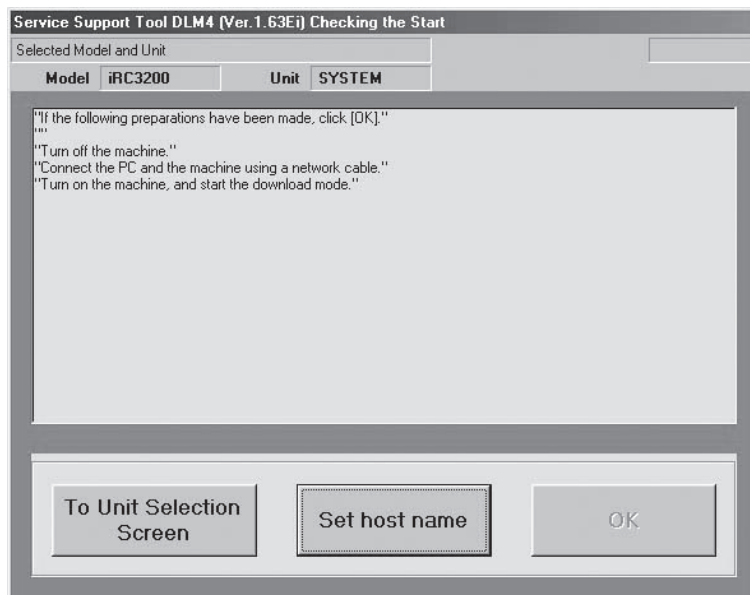

F06-301-04

- 4) The machine's IP address is entered automatically. Click [OK].

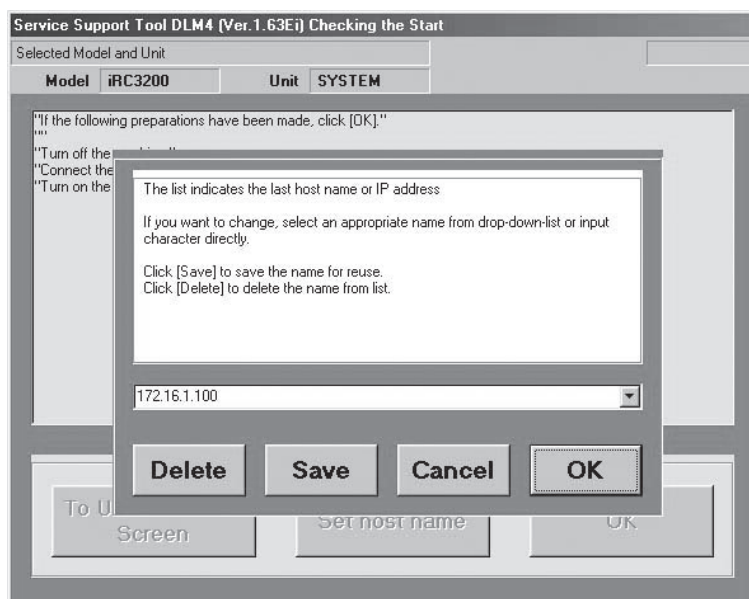

F06-301-05

- 5) Click [OK] to start connection.

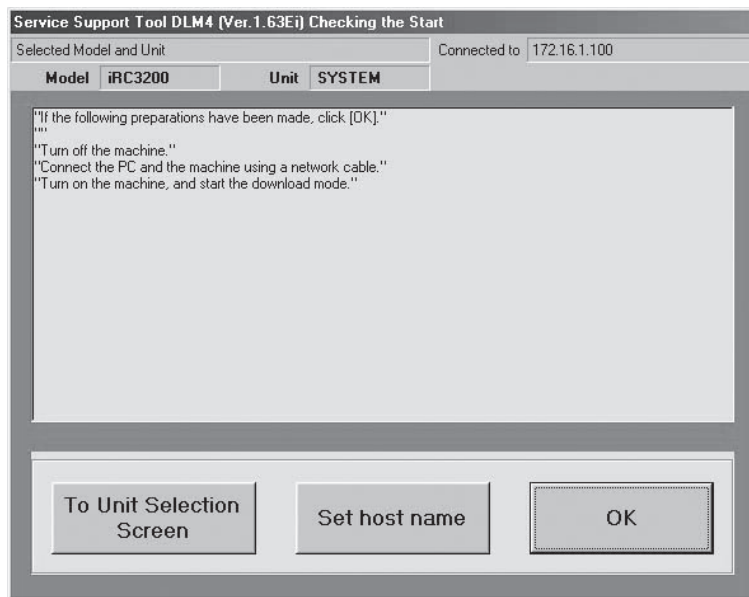

F06-301-06

6) When a connection has been made and the following screen has appeared, click [OK].

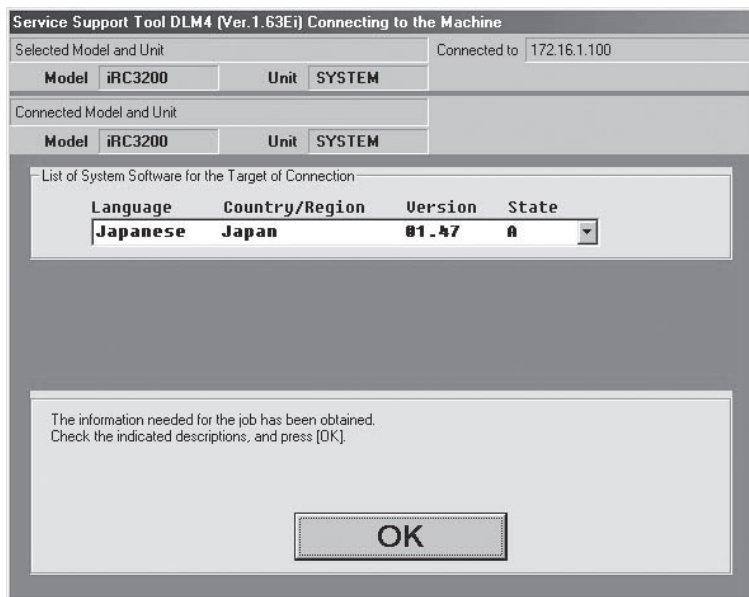

F06-301-07

7) Click [System Software Download].

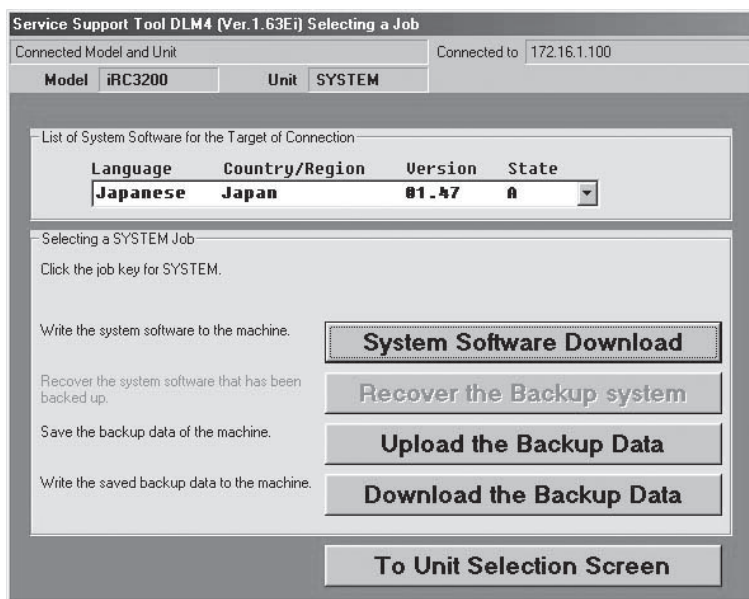

F06-301-08

- 8) Select the version to download, and click [Start].

Service Support Tool DLM4 (Ver.1.63Ei) Selecting a Version

Connected Model and Unit: Model **iRC3200** Unit **SYSTEM** Connected to 172.16.1.100

List of System Software for the Target of Connection

Language	Country/Region	Version	State
Japanese	Japan	01.47	A

System Software Versions Available for Selection
Click the appropriate version to select from among the available system software versions.
Information on the selected version will be indicated at the bottom.

Language	Country/Region	Version
English	USA	01.47
English	USA	03.02
Japanese	Japan	01.16
Japanese	Japan	01.47

Selected Version

Language: **English** Country/Region: **USA** Version: **01.47** **Start**

Previous Screen

F06-301-09

- 9) When the results of the downloading are indicated, click [OK].

Service Support Tool DLM4 (Ver.1.63Ei) Downloading the SYSTEM

Connected Model and Unit: Model **iRC3200** Unit **SYSTEM** Connected to 172.16.1.100

List of System Software for the Target of Connection

Language	Country/Region	Version	State
Japanese	Japan	01.47	A

Selected System Software

Language: **English** Country/Region: **USA** Version: **01.47**

Result of Downloading

The check sums of all files have matched.

File Name	Norm...	Obtai...	Evalu...
iRC3200W-USen0147-1355.PRG	1355	1355	OK
iRC3200N-xx0147-D015-Sub.PRG	D015	D015	OK
iRC3200N-xx0147-6E49-ICC.PRG	6E49	6E49	OK

OK

F06-301-10

10) Click [To Unit Selection Screen].



Never turn off the machine while the following screen is shown. Otherwise, writing to the HDD will be suspended, preventing the machine to start up.

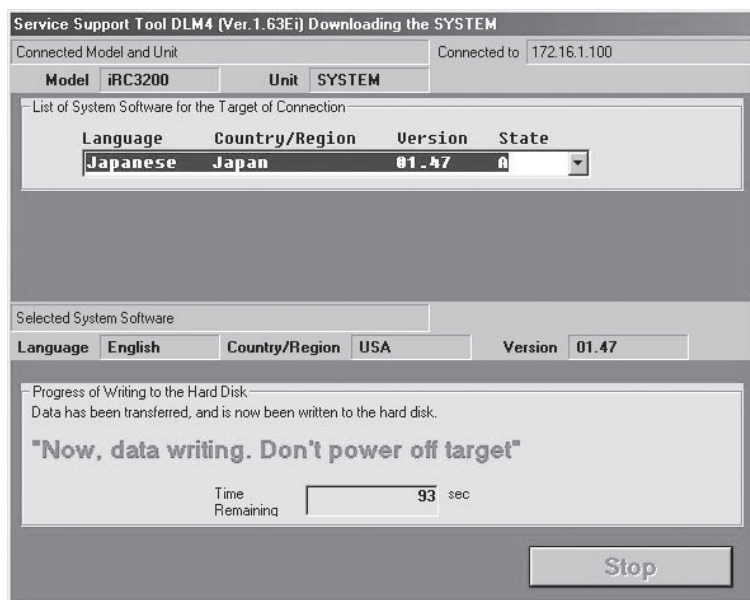

F06-301-11

If the machine fails to start up, execute formatting (BOOTDEV) using HDFormat and download the following: system software, language files, and RUI files.

3.2 Downloading the Language/RUI Files

3.2.1 Outline

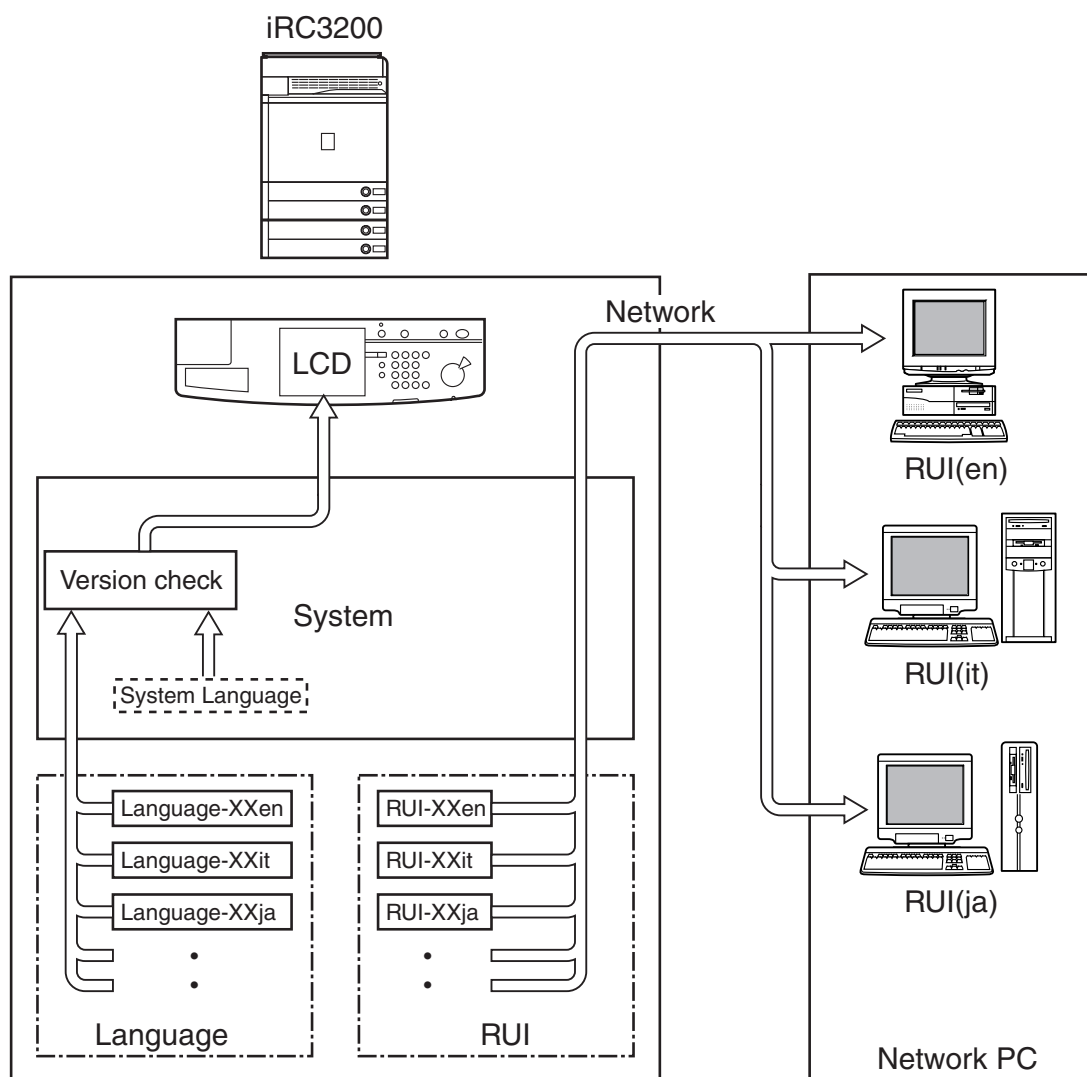

F06-302-01

Language used on control panel LCD

Check the versions of the system software and language files.

- If the versions are correct, selections may be made in user mode:

```
user mode>common specifications settings>display
language switchover
```

- If the versions are not correct, 'E744' will be indicated.

Turn off and then on the main power so that the system language will be used:

```
System Language
System-JP ja: Japanese (inside Japan)
System-USen: English (outside Japan)
```

Language used in RUI

Select on the RUI.

A specific language may be selected for a specific PC.

Language code	Language	Language code	Language
de	German	it	Italian
en	English	ja	Japanese
fr	French		



E744

- Indicates that the version of the system software and that of the language files do not match.
- Uses the (built-in) system language for the LCD when the main power is turned off and then on.
- To correct, download the language that matches the version of the system software.

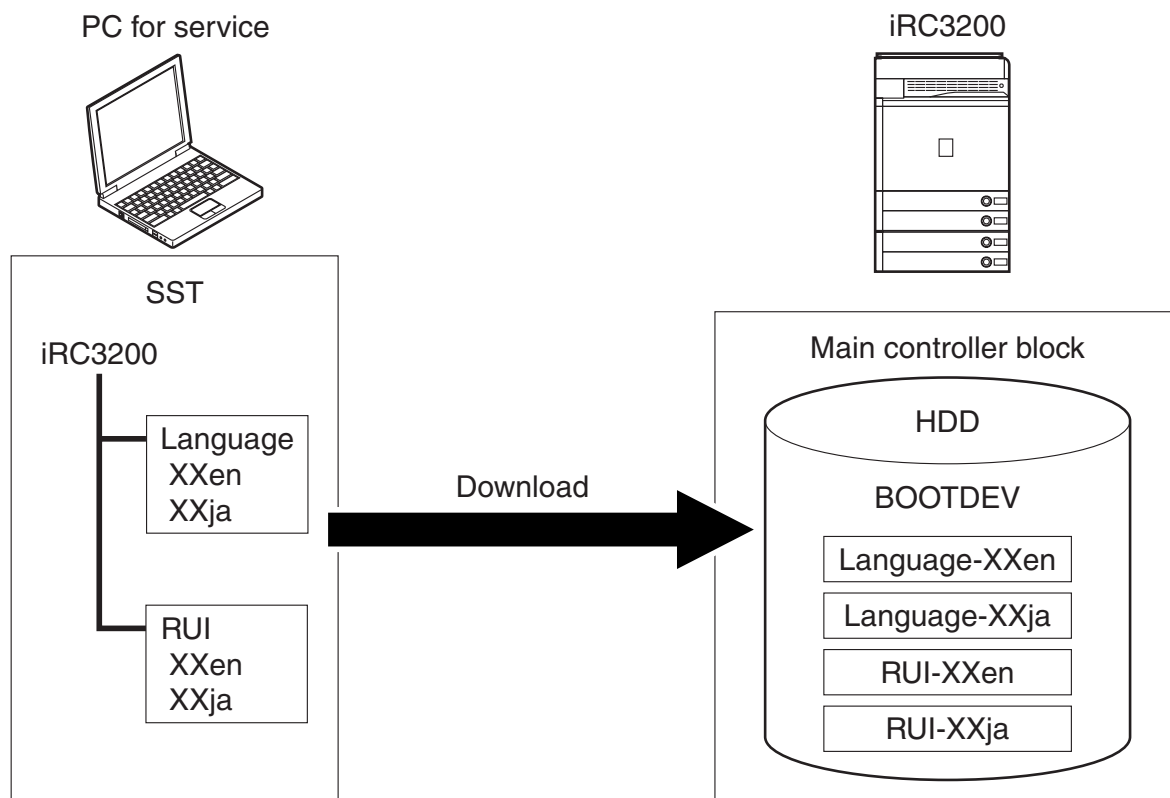

F06-302-02

3.2.2 Downloading Procedure

Procedure

Downloading may take place when the machine is in normal or in safe mode. The following describes downloading of the language files; both language and RUI files may be downloaded in common among models (here, the iRC3200 is selected):

- 1) Click [To Next] under 'Download/Upload'.

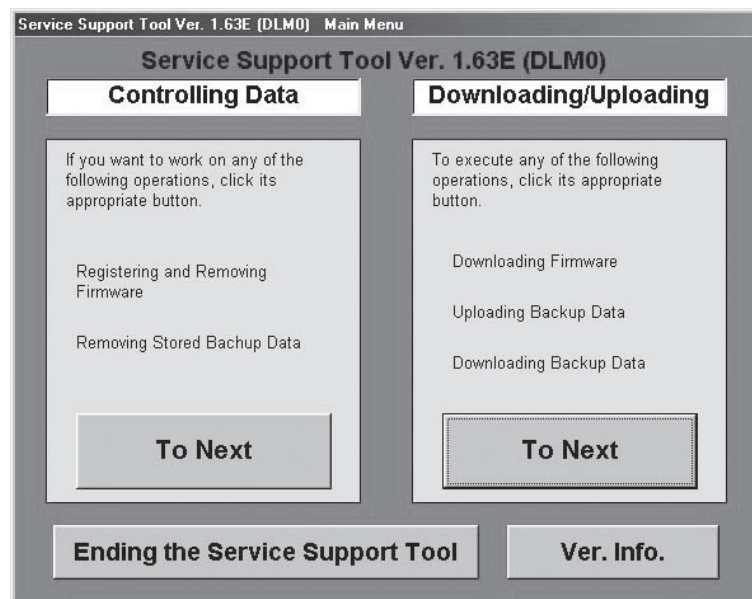

F06-302-03

- 2) Select 'language' for the iRC3200, and click [Connect].

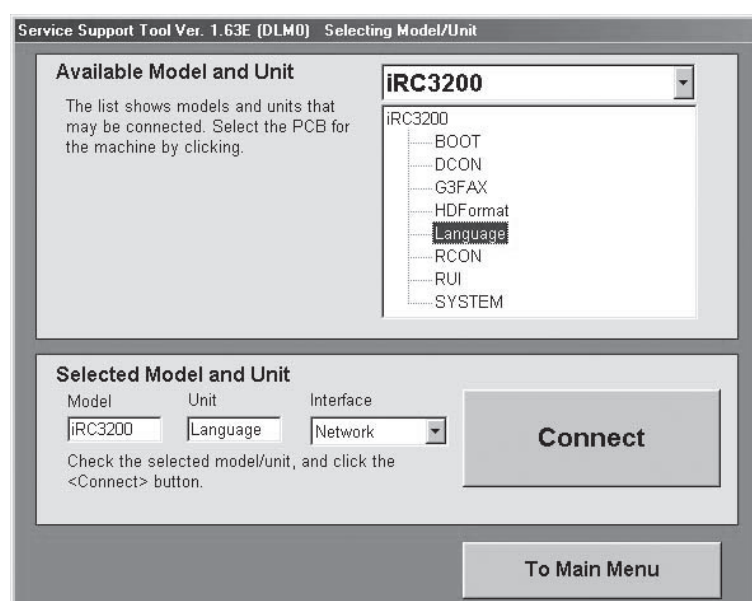

F06-302-04

3) Click [Set host name].

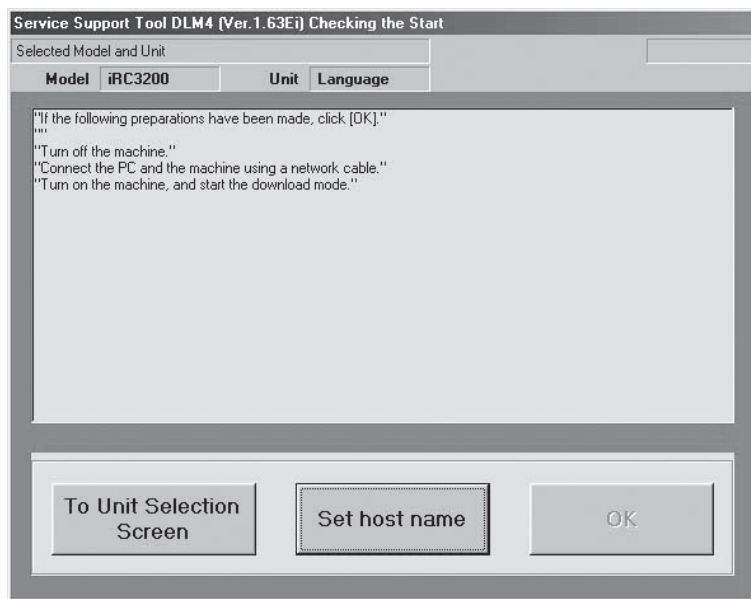

F06-302-05

4) The machine's IP address will be entered automatically; click [OK].

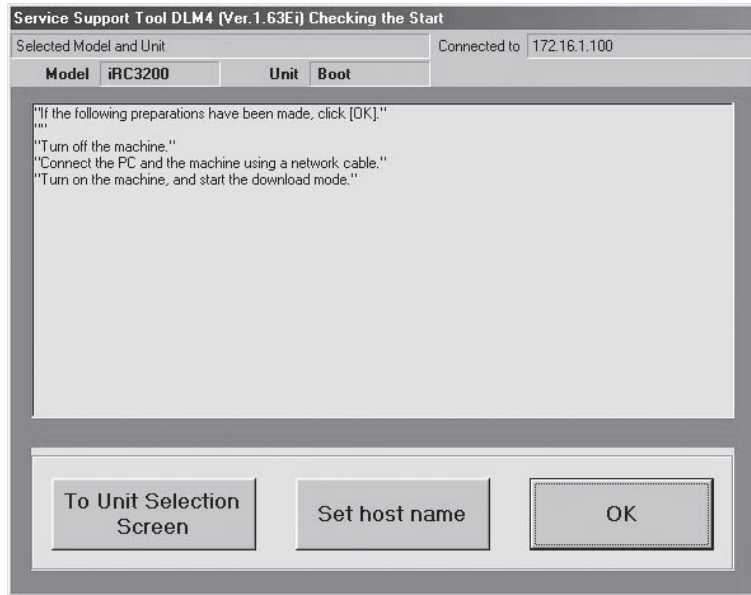

F06-302-06

- 5) Click [OK] to start making a connection.

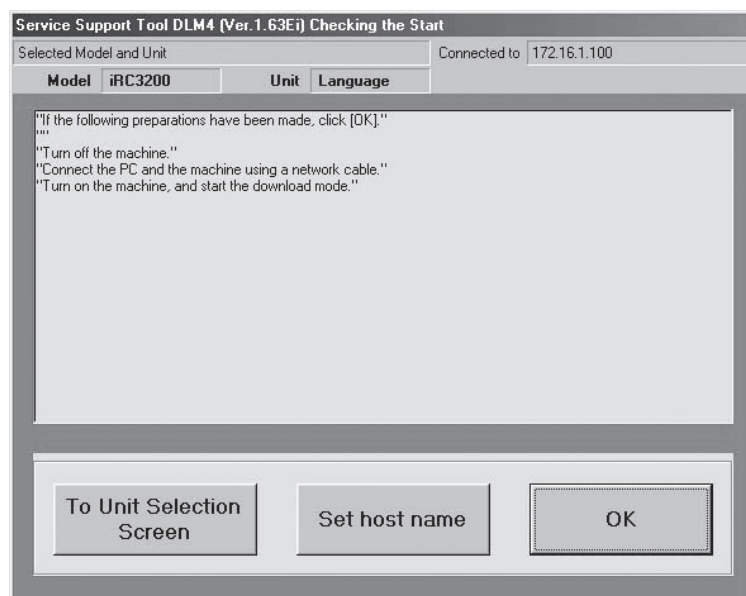

F06-302-07

- 6) When a connection has been made and the following screen has appeared, click [OK].

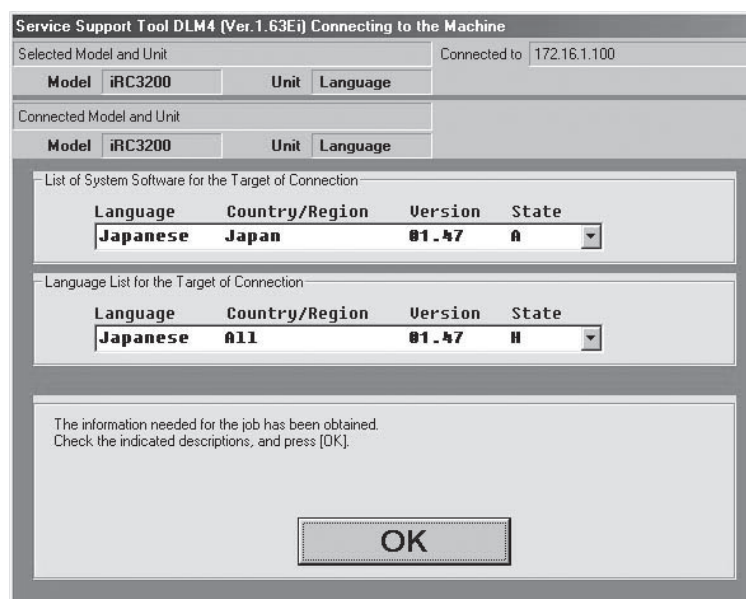

F06-302-08

7) Click [Language Download].

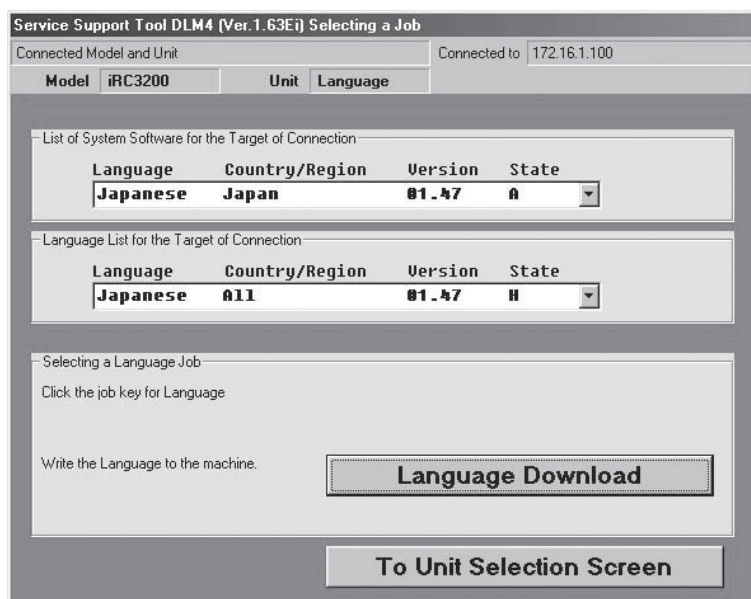

F06-302-09

8) Select the version to download, and click [Start].

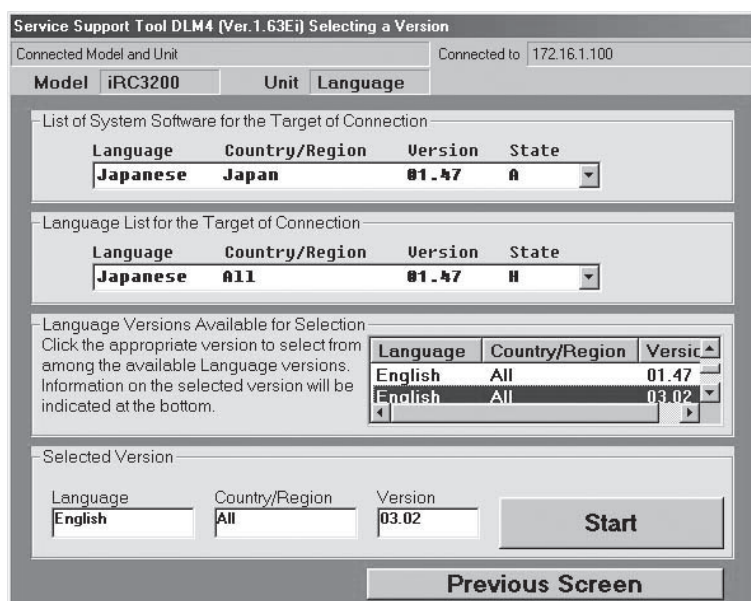

F06-302-10

- 9) When the result of downloading is indicated, click [OK].

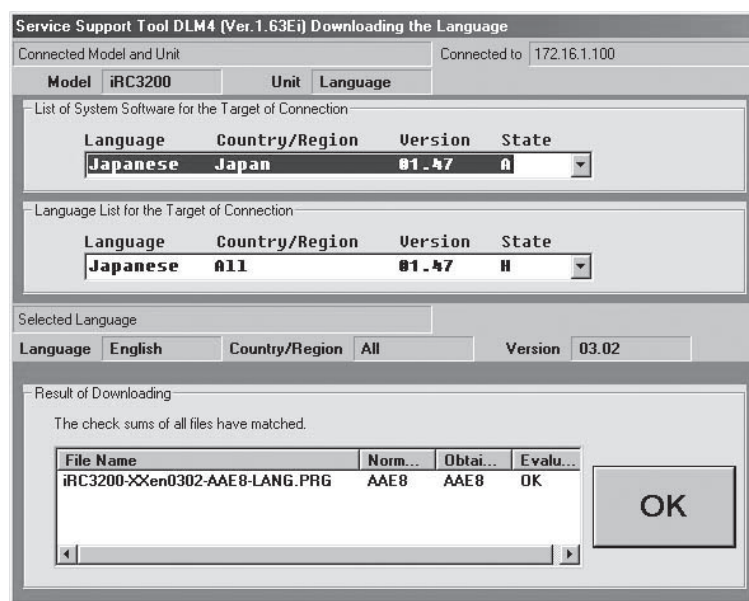

F06-302-11

- 10) Click [To Unit Selection Screen].



Never turn off the machine while the following screen is indicated. Otherwise, writing to the HDD will be suspended, preventing the machine from starting up.

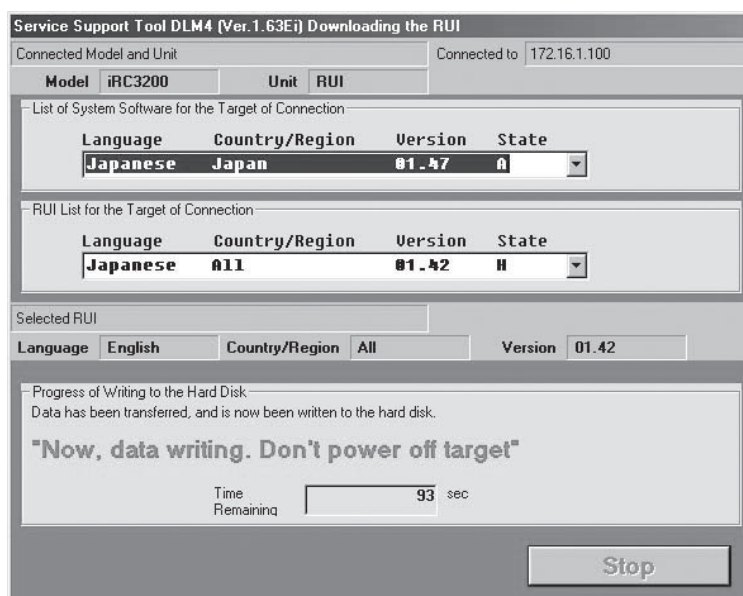

F06-302-12

If the machine fails to start up, execute formatting (BOOTDEV) using HDFormat, and download the following: system software, language files, RUI files.

3.3 Downloading Boot ROM Files

3.3.1 Outline

The boot ROM differs according to the machine's functions:

Boot ROM type	Service mode indication	Country	Machine function
Copy	xx.yyC	Worldwide	Copy
LIPS	xx.yyL	Japan	Copy+LIPS
PSPCL	xx.yyN	Outside Japan	Copy+PSPCL

T03-303-01

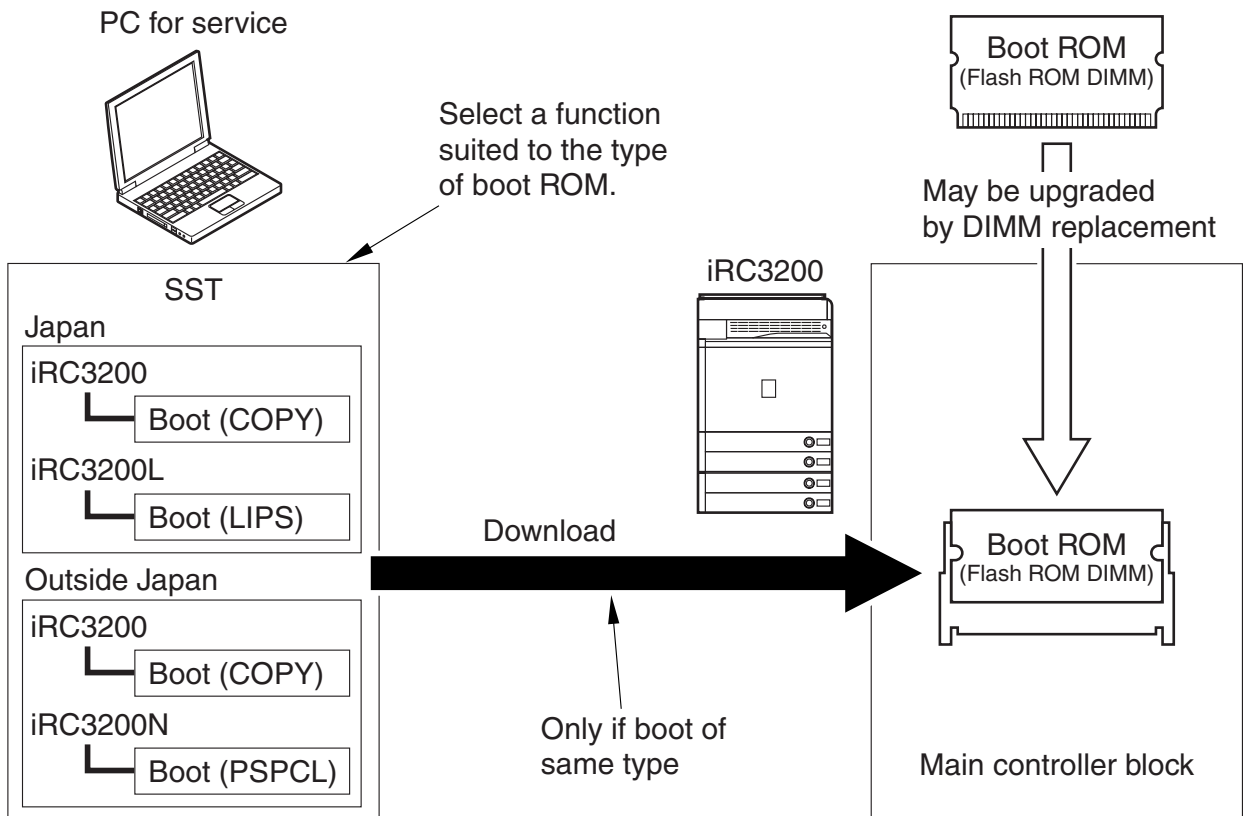

F06-303-01



If downloading fails, the boot ROM will have to be replaced.

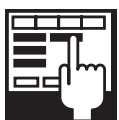

The type of boot ROM mounted to the machine may be checked using service mode:

COPIER>Display>VERSION>BOOT-ROM

Copy: xx.yyC

LIPS: xx.yyL (Japan)

PSPCL: xx.yyN (outside Japan)

3.3.2 Downloading Procedure

Downloading may take place in normal mode or in safe mode.

- 1) Click [next] under 'download/upload'.

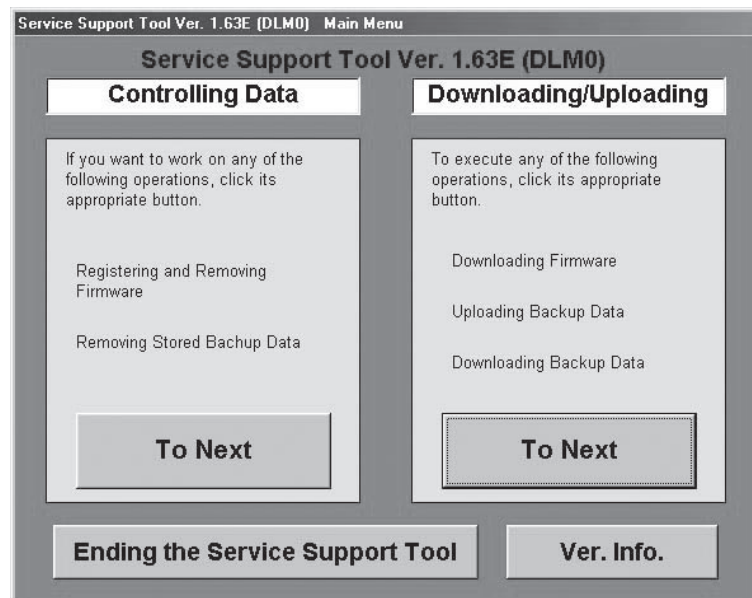

F06-303-02

- 2) Select 'Boot' for the iRC3200 (if a LIPS model, select iRC3200L; if a PSPCL model, select iRC3200N); then, click [Connect].

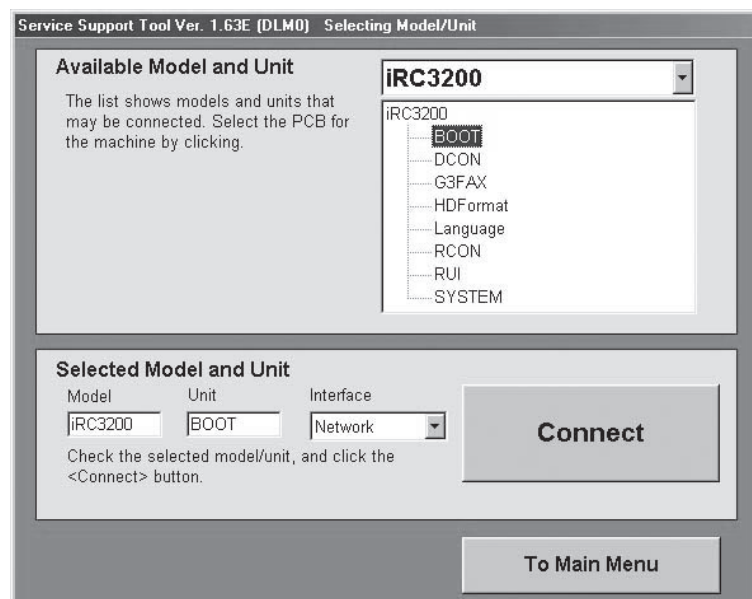

F06-303-03

3) Click [Set host name].

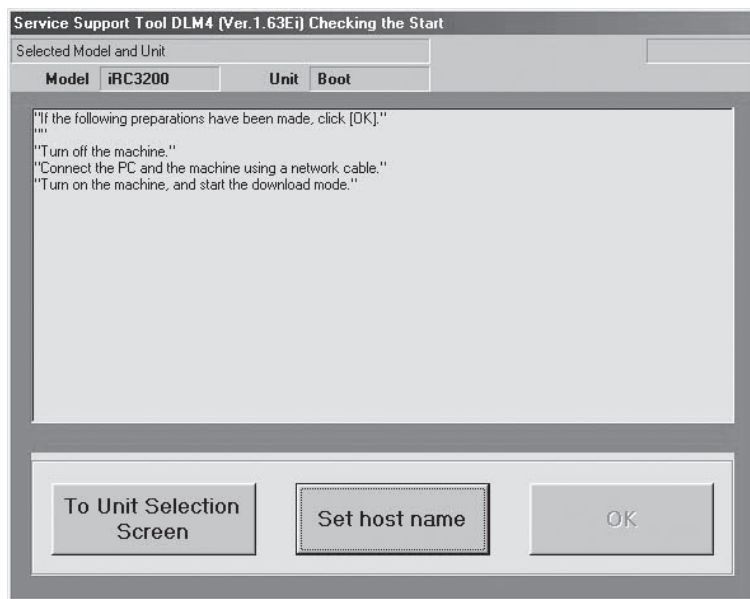

F06-303-04

4) The machine's IP address will be entered automatically; click [OK].

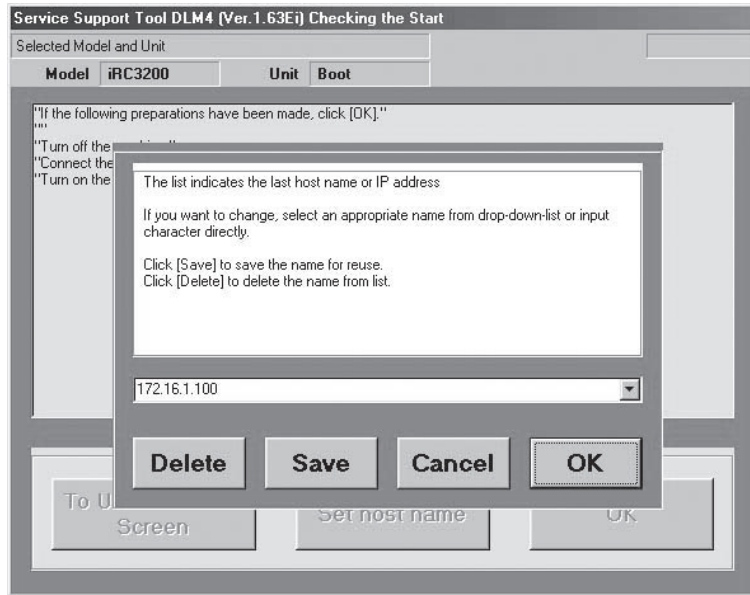

F06-303-05

- 5) Click [OK] to start making a connection.

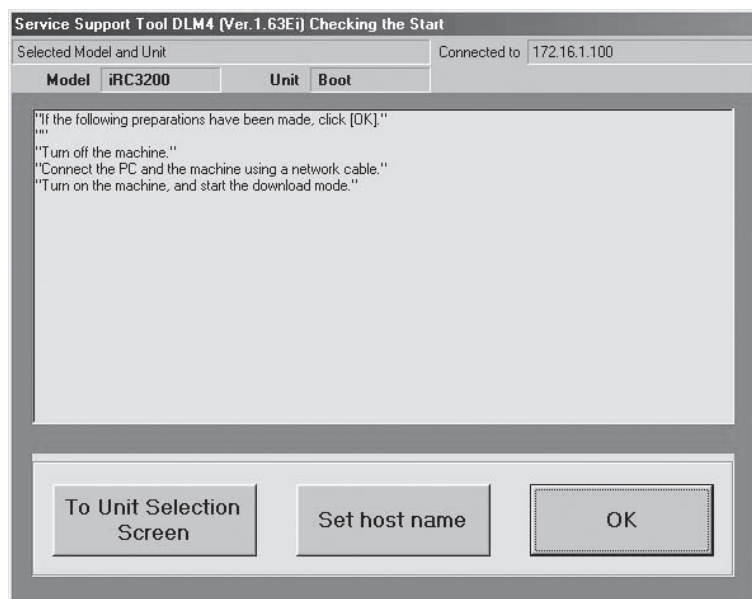

F06-303-06

- 6) When a connection has been made and the following screen has appeared, click [OK].

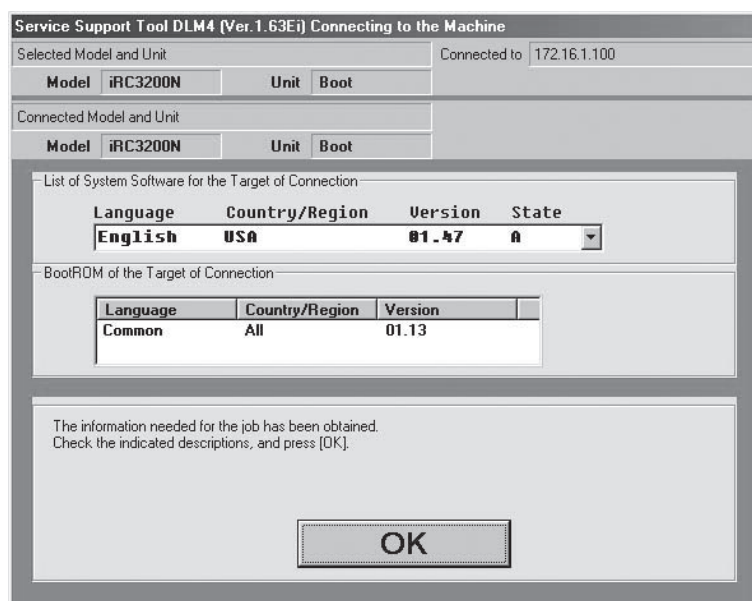

F06-303-07

If the wrong type of boot ROM has been selected, the following screen will appear; select the correct model:

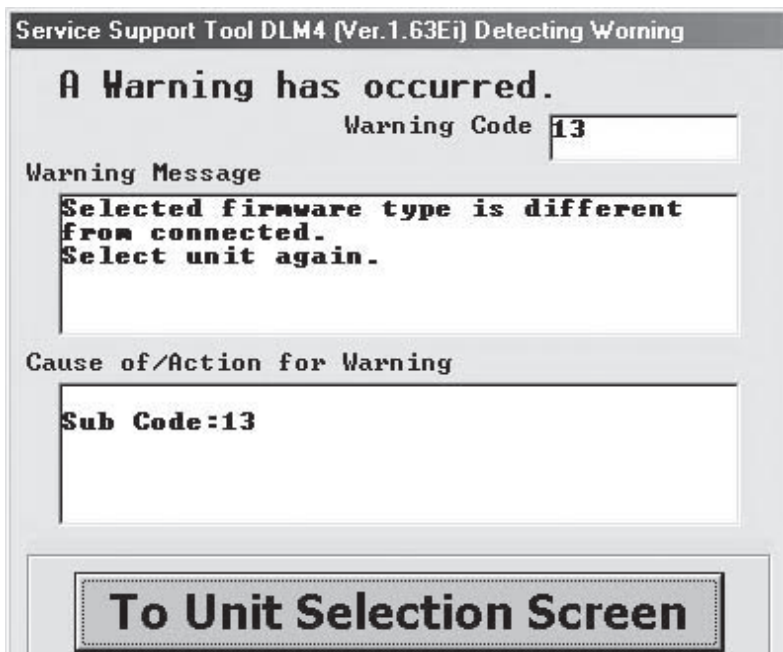

F06-303-08

7) Click [Boot ROM Download].

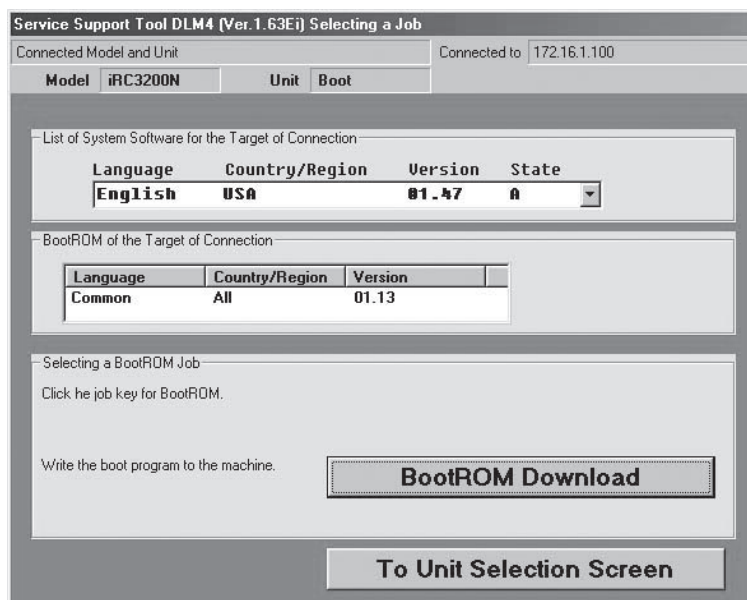

F06-303-09

- 8) Select the version to download, and click [Start].

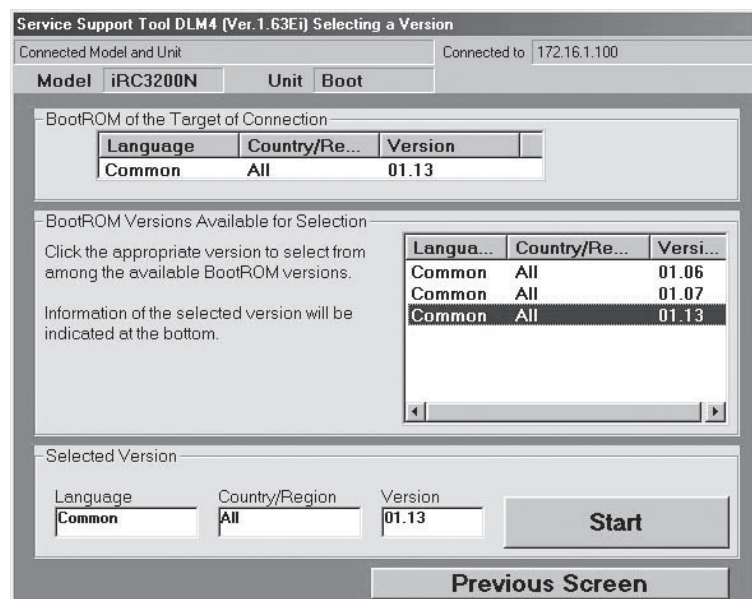

F06-303-10

- 9) When the result of downloading has appeared, click [OK].

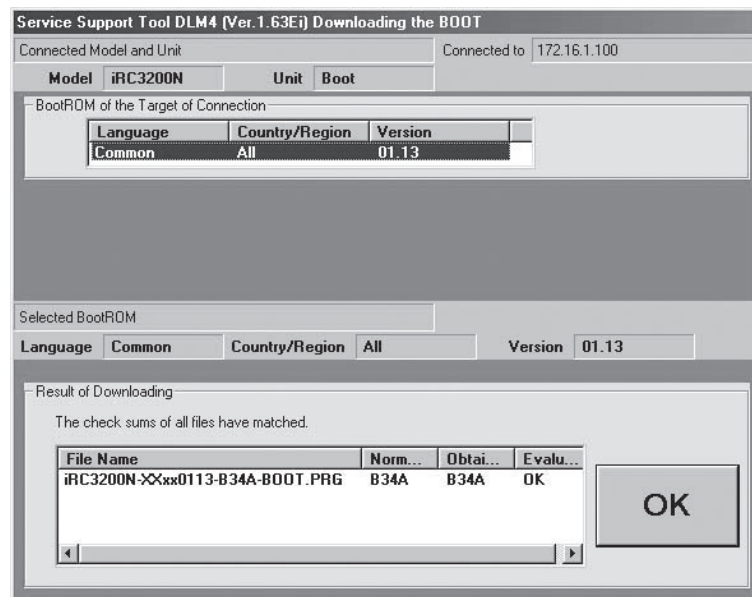

F06-03-11

10) Click [return to unit select screen].

After Downloading

When you have upgraded the boot ROM, be sure to turn off and then on the machine's main power switch so that the new version will be validated.



Never turn off the machine while the following screen is indicated. Otherwise, the machine will fail writing to the boot ROM and may not start up.

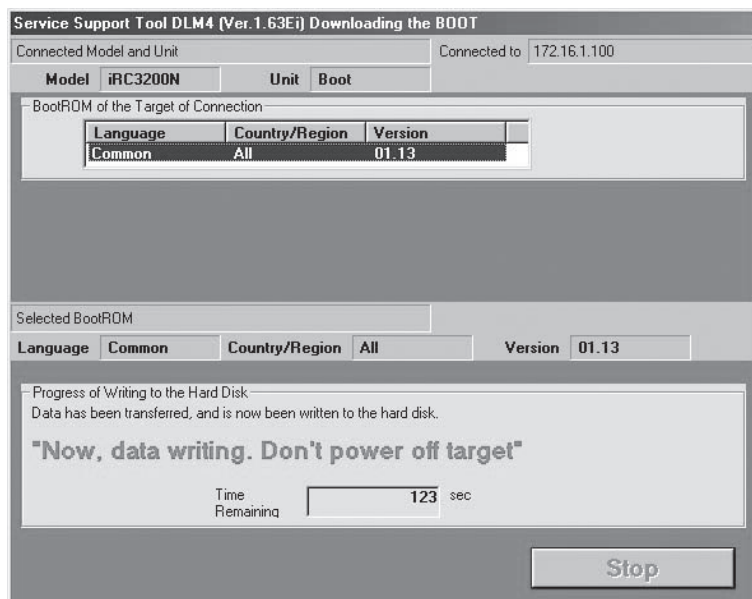

F06-303-12

If the machine fails to start up, replace the boot ROM.

3.4 Downloading DC Controller/Reader Controller Files

3.4.1 Outline

The DC controller/reader controller files are downloaded by way of the main controller block. Both DC controller PCB and the reader controller PCB are equipped with boot ROMs, permitting retries if downloading fails.

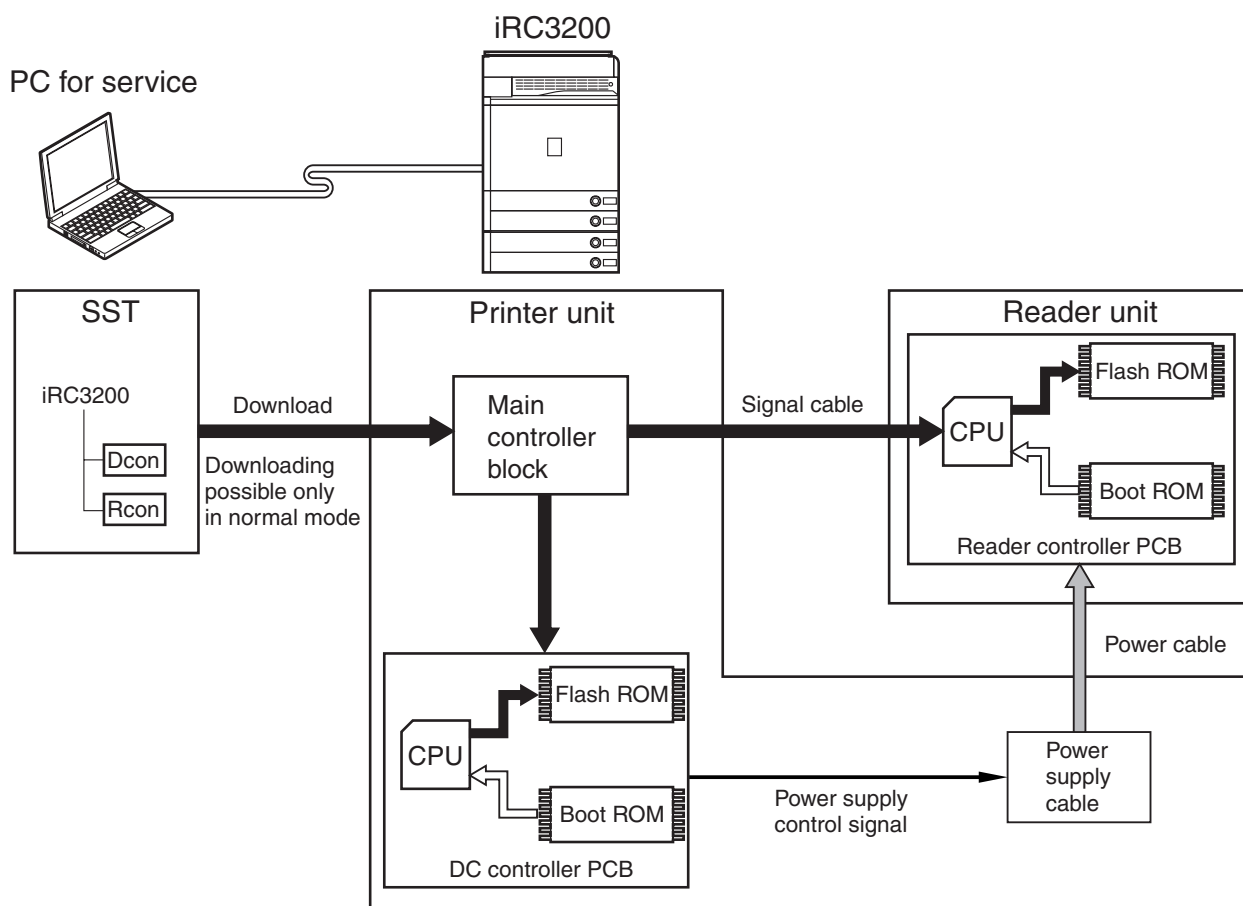

F06-304-01



Unless the DC controller has started up normally, the power supply control signal will not be validated, not supplying the reader unit with power and not permitting downloading of reader controller files.

3.4.2 Downloading Procedure

Making Pre-Checks

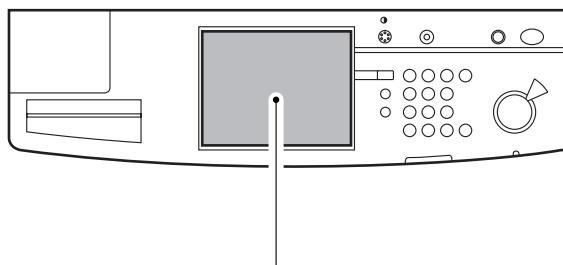
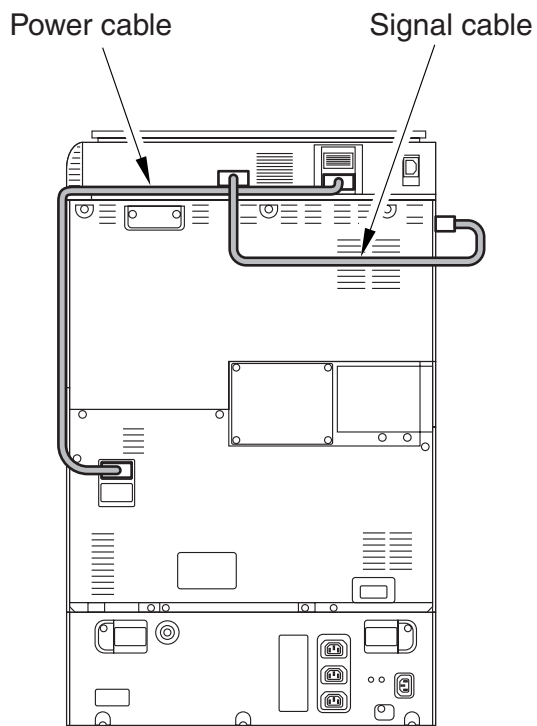

- No error code must be indicated.
- In the case of downloading reader controller files, the version of 'DCCON' must be indicated in service mode.

F06-304-02

Procedure

The following describes downloading of DC controller files (both DC controller and reader controller files are shared in common among models; herein, the iRC3200 is selected):

- 1) Click [To Next] under 'Download/Upload'.

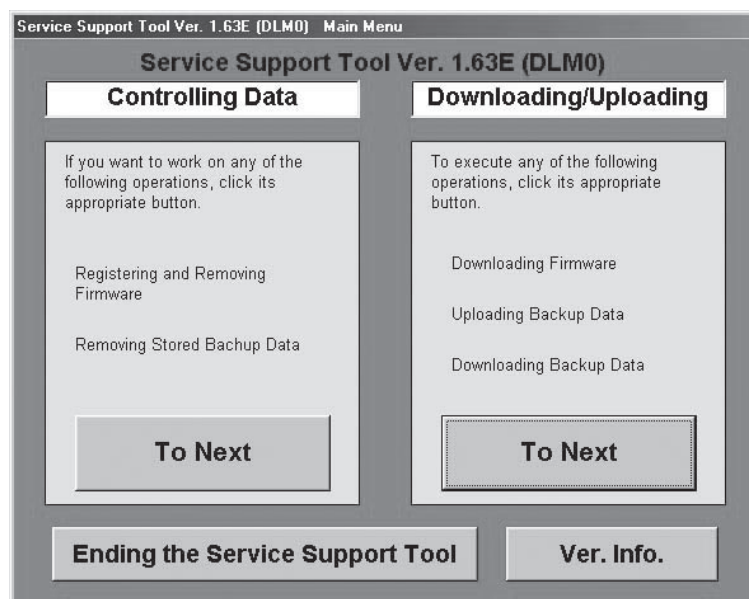

F06-304-03

- 2) Select 'DCON', and click [Connect].

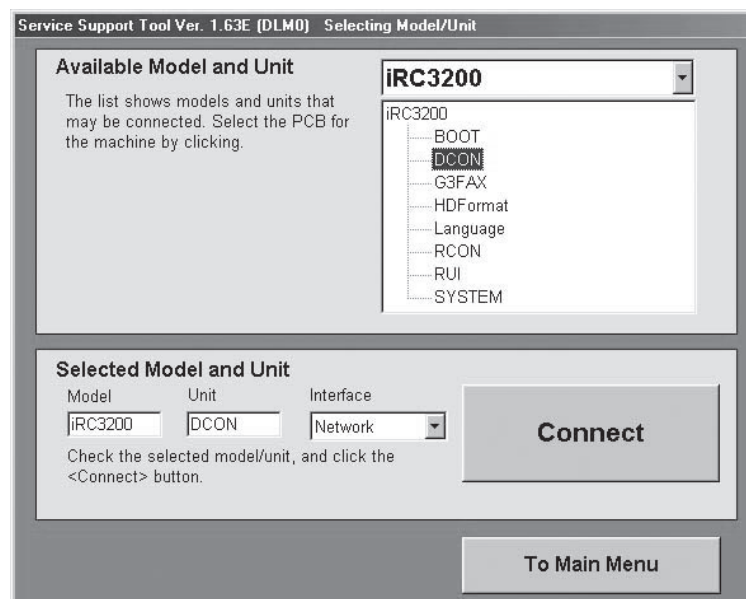

F06-304-04

3) Click [Set host name].

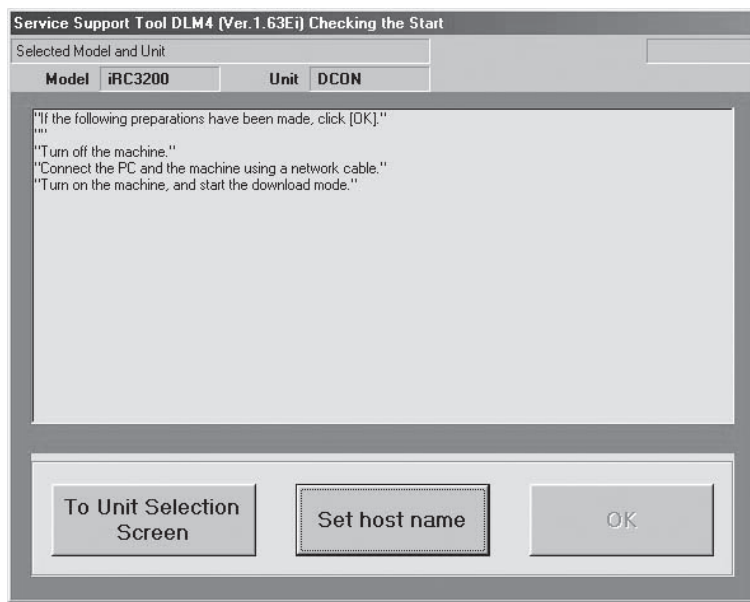

F06-304-05

4) The machine's IP address is entered automatically; click [OK].

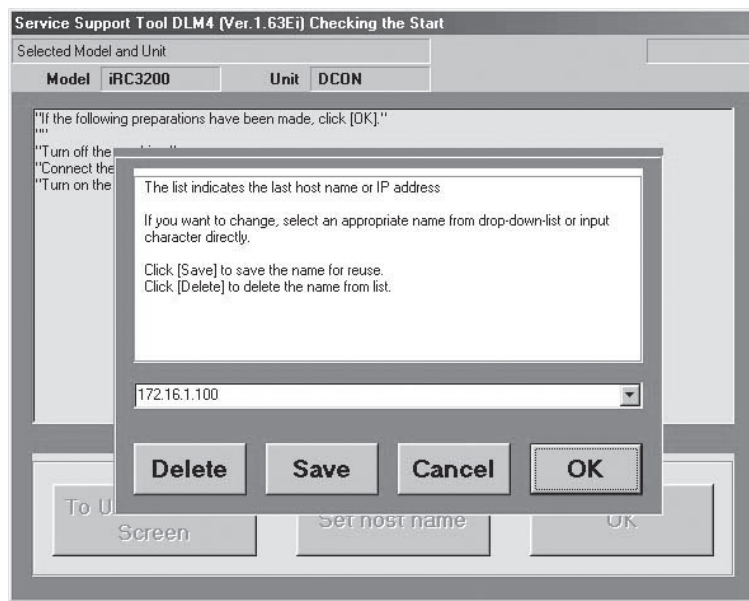

F06-304-06

- 5) Click [OK] to start making a connection.

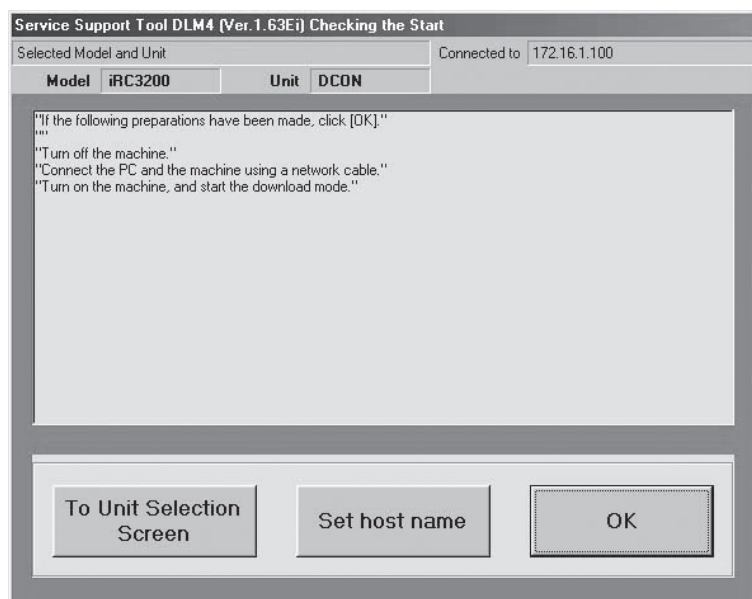

F06-304-07

- 6) When a connection has been made and the following screen has appeared, click [OK].

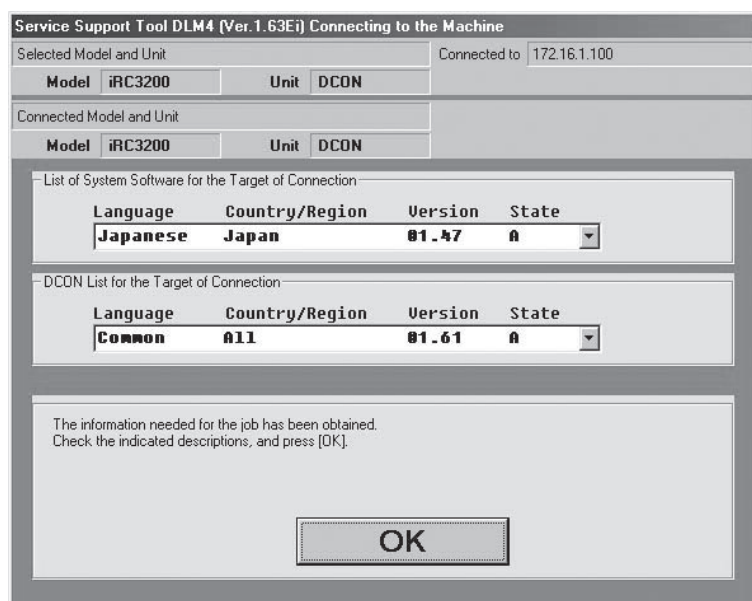

F06-304-08

7) Click [DCON Download].

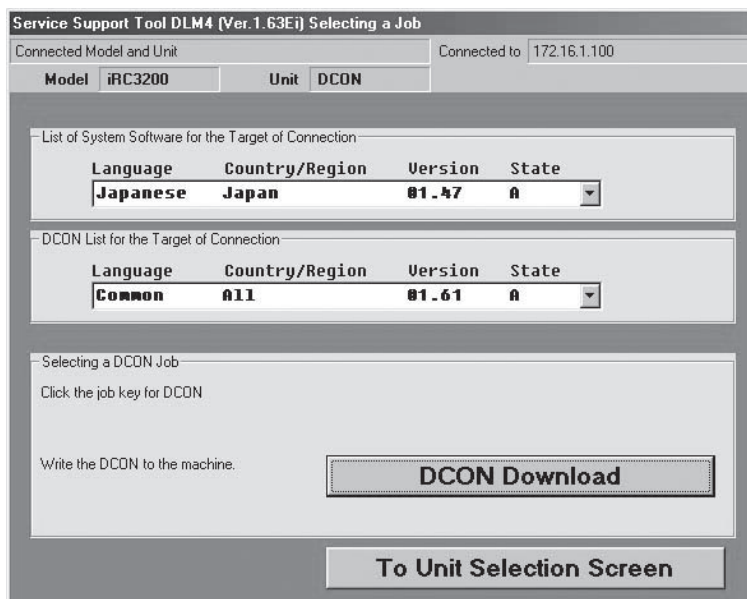

F06-304-09

8) Select the version to download, and click [Start].

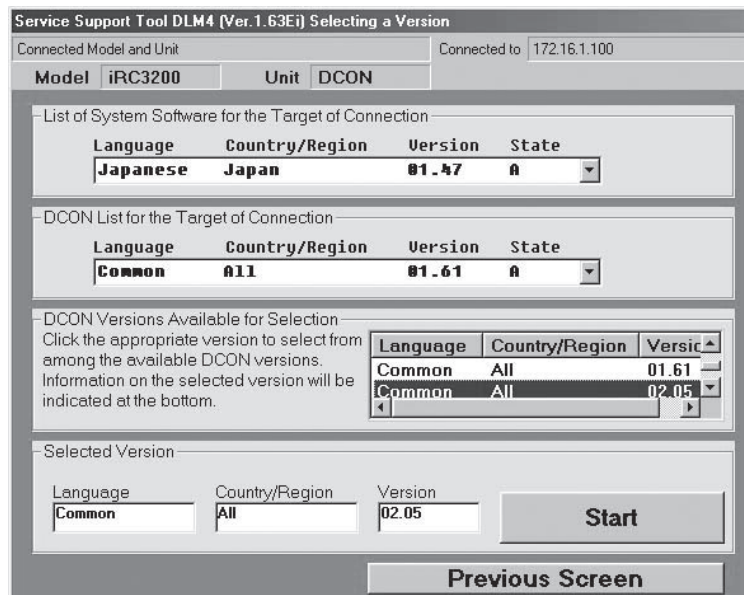

F06-304-10

- 9) When the result of downloading is indicated, click [OK].

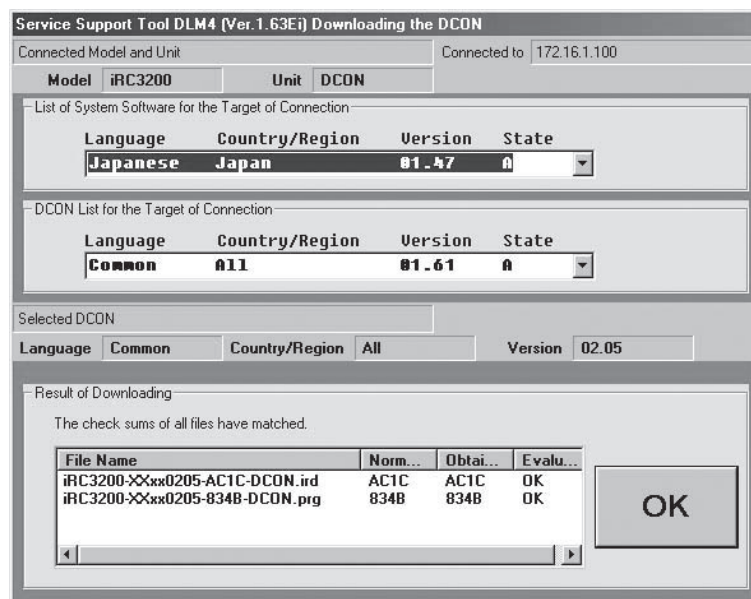

F06-304-11

- 10) Click [return to unit selection screen].

After Downloading

If you have downloaded DC controller or reader controller files, be sure to turn off and then on the main power switch. You cannot download the DC controller and reader controller files in succession.



Never turn off the machine while the following screen is indicated. Otherwise, writing to 'DCON/RCON' can fail, indicated by the following error codes:

DCON: E733
 RCON: E732

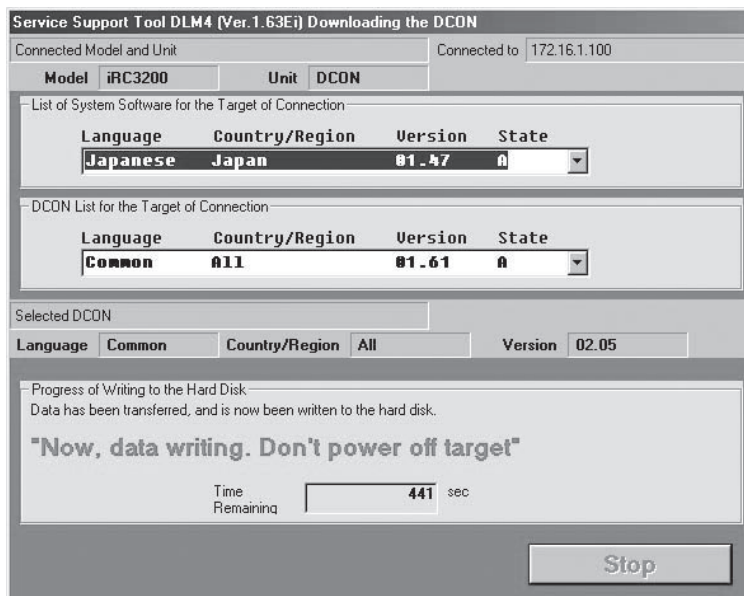

F06-304-12

If an error code is indicated, be sure to download the appropriate firmware.

3.5 Downloading the G3Fax Files

3.5.1 Outline

The G3Fax files are downloaded by way of the main controller block.

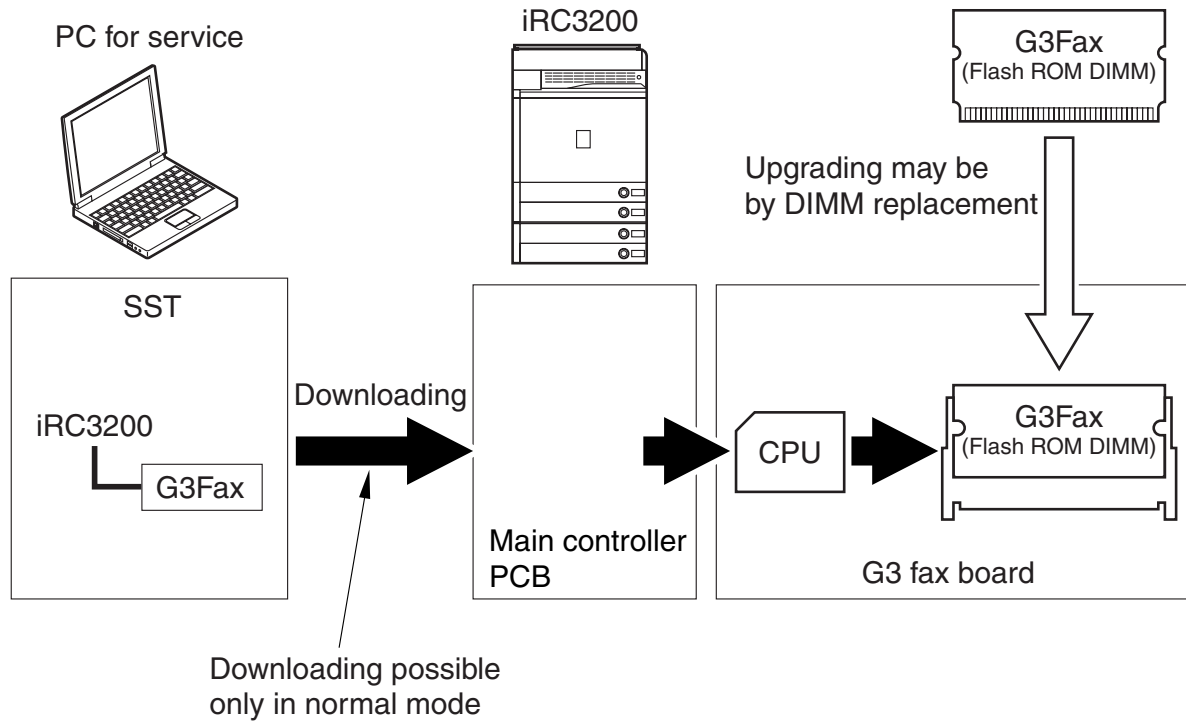

F06-305-01



If downloading fails, the flash ROM DIMM must be replaced.

3.5.2 Downloading Procedure

Procedure

Use normal mode for downloading.

- 1) Click [To Next] under 'Download/Upload'.

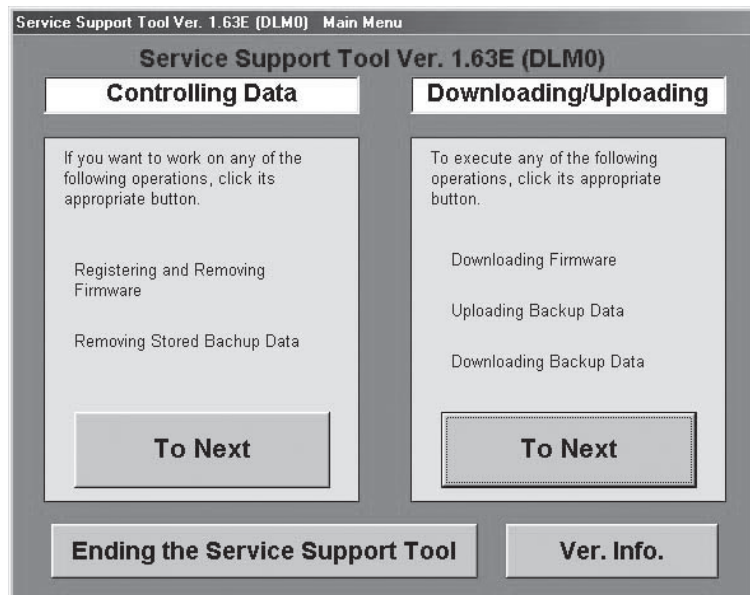

F06-305-02

- 2) Select 'G3FAX', and click [Connect].

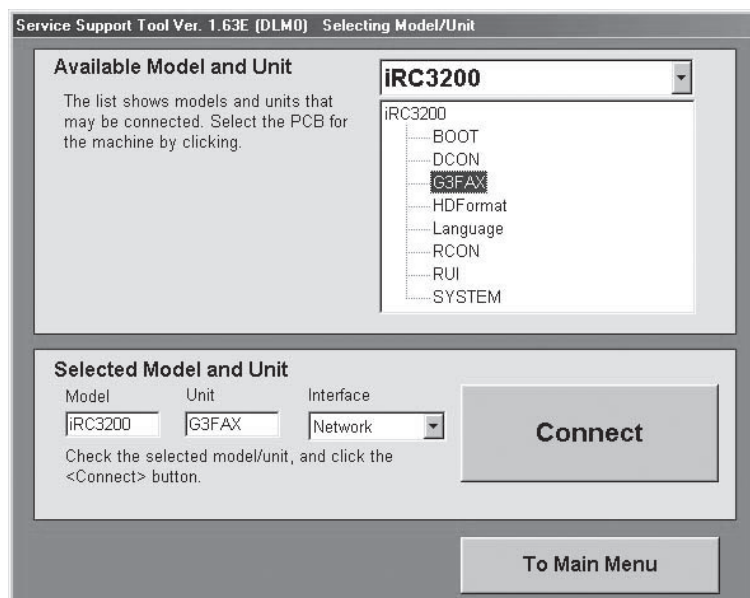

F06-305-03

- 3) Click [Set host name].

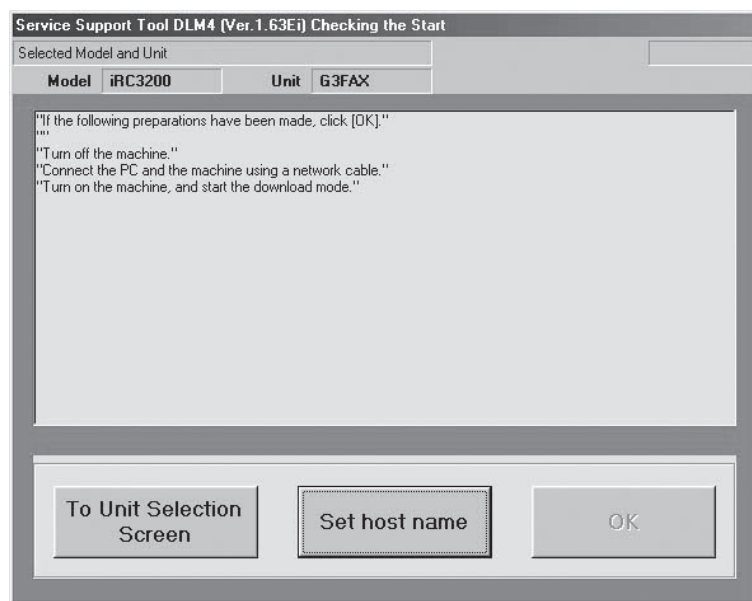

F06-305-04

- 4) The machine's IP address is entered automatically; click [OK].

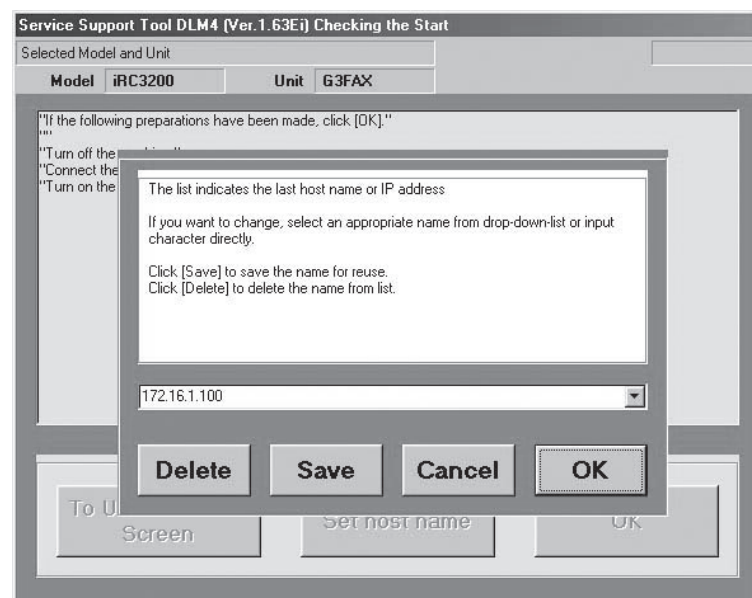

F06-305-05

5) Click [OK] to start making a connection.

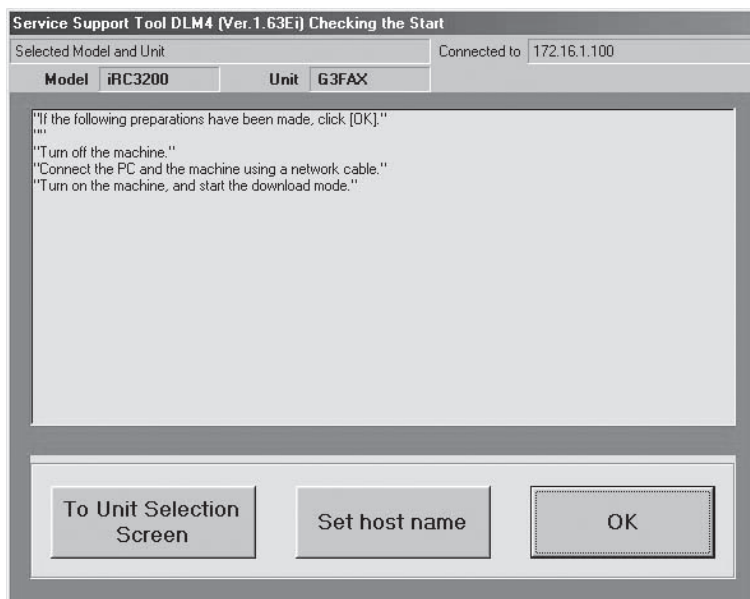

F06-305-06

6) When a connection has been made and the following screen has appeared, click [OK].

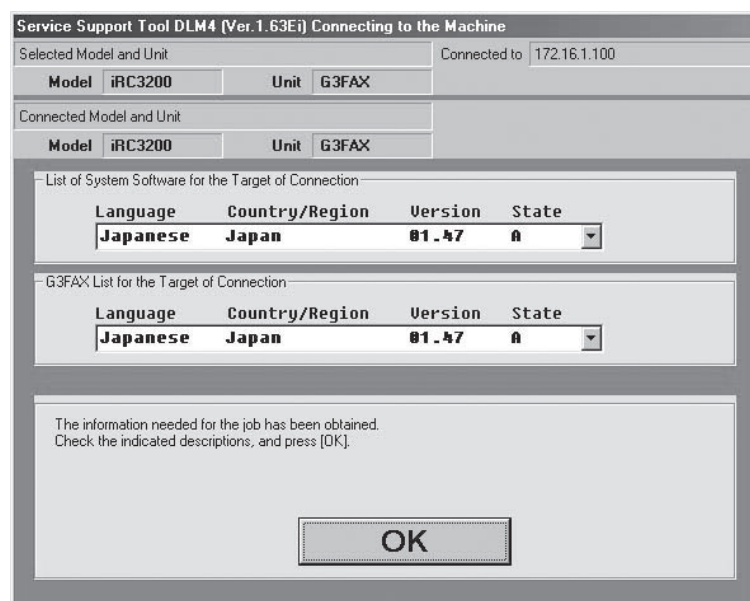

F06-305-07

7) Click [G3Fax Download].

Service Support Tool DLM4 [Ver.1.63Ei] Selecting a Job

Connected Model and Unit: Model **iRC3200** Unit **G3FAX** Connected to: 172.16.1.100

List of System Software for the Target of Connection:

Language	Country/Region	Version	State
Japanese	Japan	01.47	A

G3FAX List for the Target of Connection:

Language	Country/Region	Version	State
Japanese	Japan	01.47	A

Selecting a G3FAX Job

Click the job key for G3FAX

Write the G3FAX to the machine.

G3FAX Download

To Unit Selection Screen

F06-305-08

8) Select the version to download, and click [Start].

Service Support Tool DLM4 [Ver.1.63Ei] Selecting a Version

Connected Model and Unit: Model **iRC3200** Unit **G3FAX** Connected to: 172.16.1.100

List of System Software for the Target of Connection:

Language	Country/Region	Version	State
Japanese	Japan	01.47	A

G3FAX List for the Target of Connection:

Language	Country/Region	Version	State
Japanese	Japan	01.47	A

G3FAX Versions Available for Selection

Click the appropriate version to select from among the available G3FAX versions. Information on the selected version will be indicated at the bottom.

Language	Country/Region	Version
Common	All	37.03

Selected Version

Language: **Common** Country/Region: **All** Version: **37.03**

Start

Previous Screen

F06-305-09

9) When the result of downloading is indicated, click [OK].

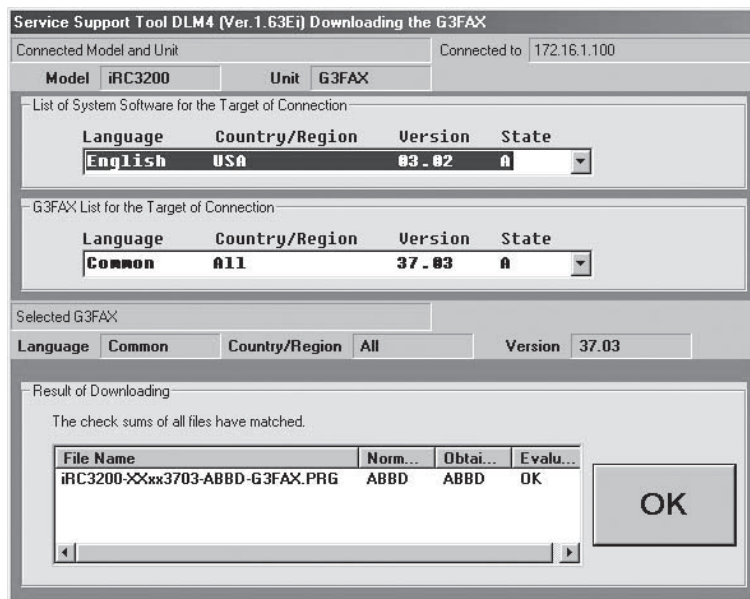

F06-305-10

10) Click [return to unit select screen].

After Downloading

When you have downloaded G3Fax files, be sure to turn off and then on the machine's main power switch.



You cannot download G3Fax files twice in succession. (Once downloading ends, the G3 fax board will be reset, leaving download mode.)

Never turn off the machine while the following screen is indicated. Writing to the flash ROM DIMM of the G3 fax board will fail, preventing the G3 fax board functions from operating normally.

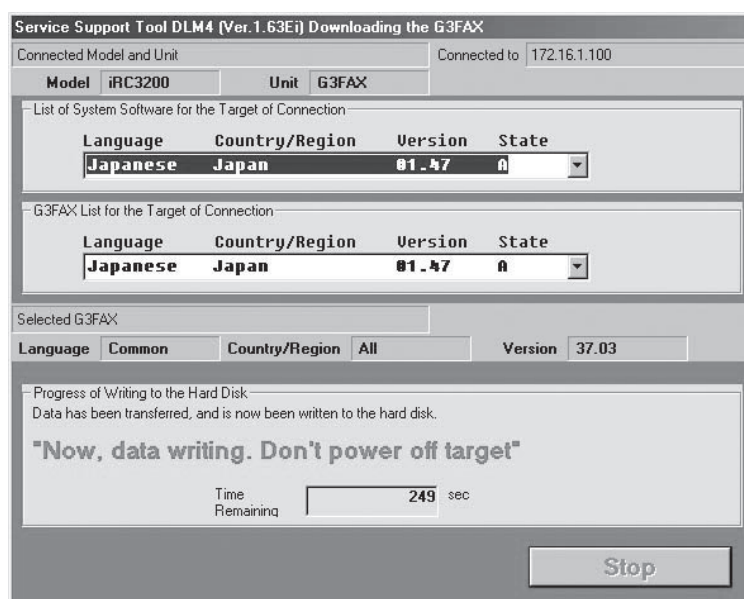

F06-305-11

If the G3 fax board fails to operate, be sure to replace the flash ROM DIMM on the G3 fax board.

4 Uploading/Downloading Backup Data

4.1 Outline

The machine's backup data is stored on the SRAM PCB, DC controller PCB, and reader controller PCB. Any backup data is selected with reference to its file name used when uploading it.

Backup data	File name selected at time of uploading
SRAM PCB (main controller block)	SramImg. bin
DC controller PCB	SramDCON. bin
Reader controller PCB	SramRCON. bin

T06-401-01

If you plan to replace the DC controller PCB or the reader controller PCB, it is a good idea to upload its data in advance, and download it after replacement so that parts counter readings and the like may be retained.

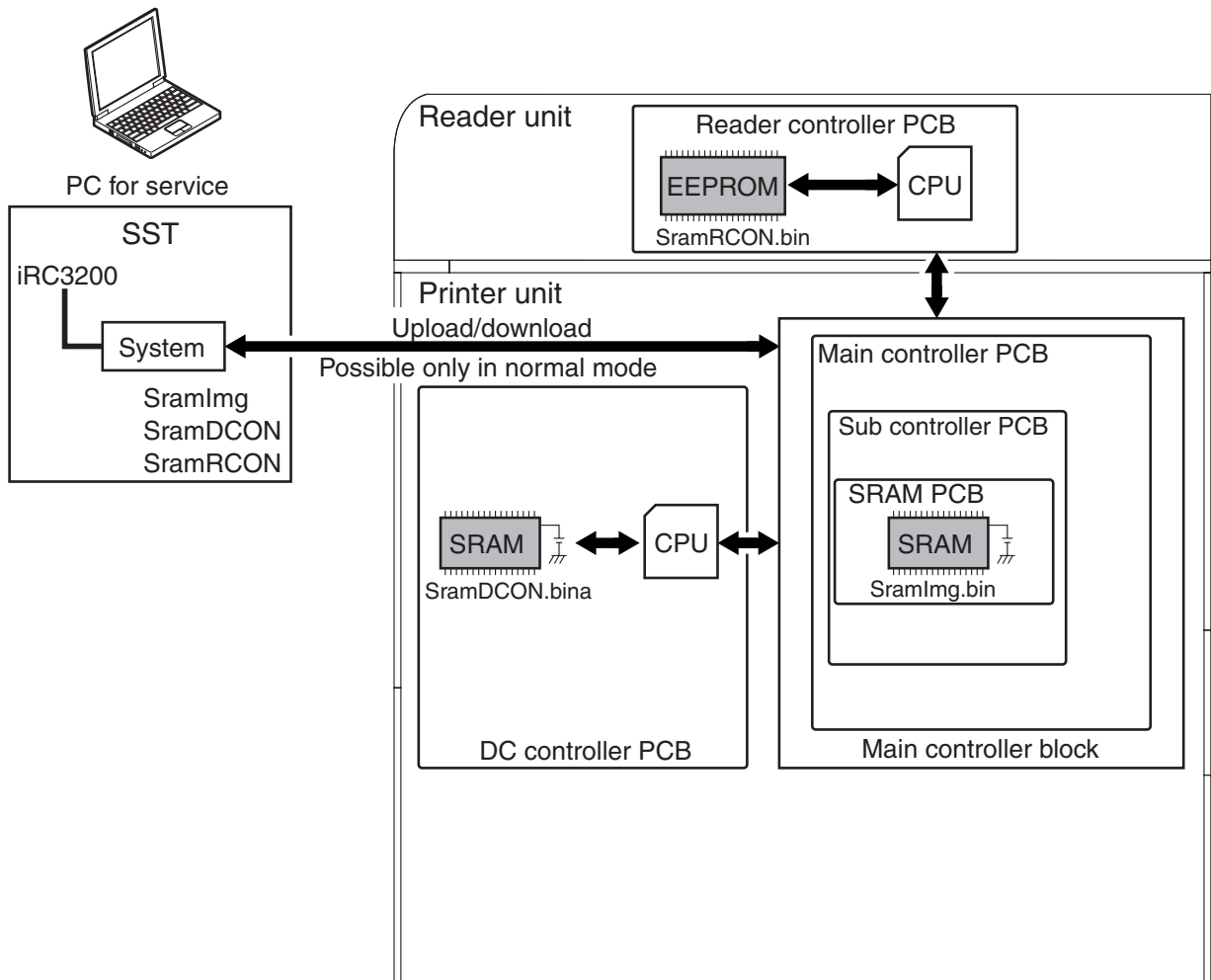

F06-401-01



If you download the SramImg data that has previously been uploaded from a specific machine to a machine with a different serial number, the image data, user mode settings, and service mode settings stored in Box or the like will all be lost. Be sure not to download the SramImg data to any other machine.

4.2 Uploading Procedure

Procedure

Use normal mode for downloading.

- 1) Click [To Next] under 'Download/Upload'.

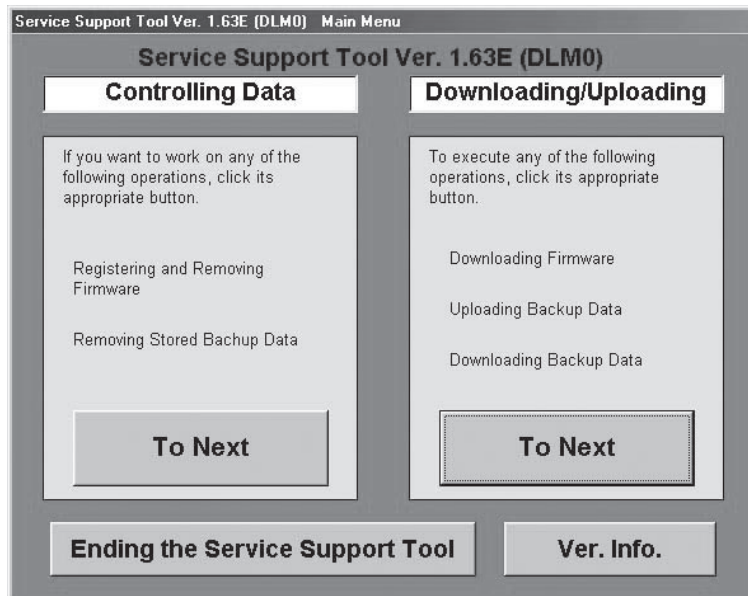

F06-402-01

- 2) Select 'SYSTEM' under 'iRC3200', and click [Connect].

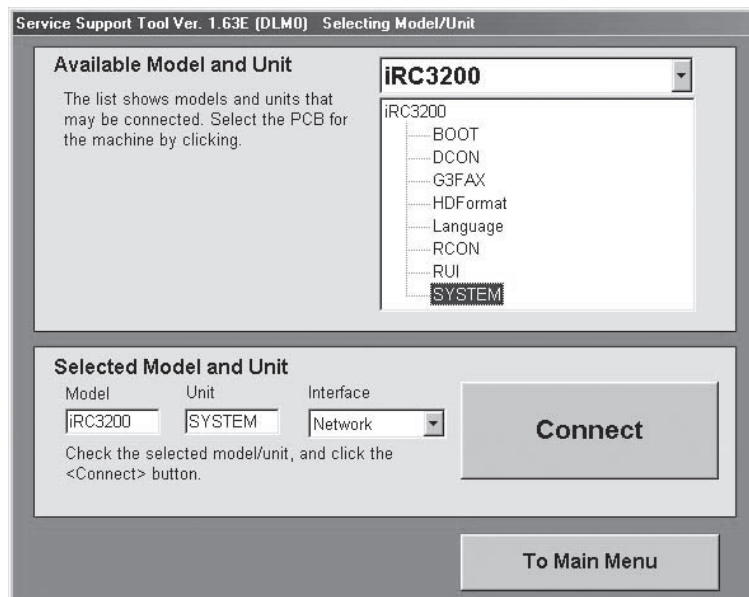

F06-402-02

3) Click [Set host name].

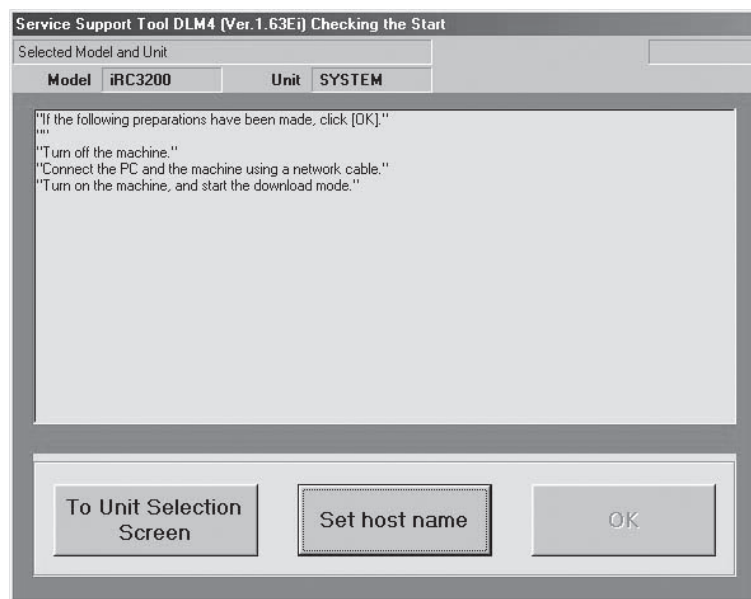

F06-402-03

4) The machine's IP address is entered automatically; click [OK].

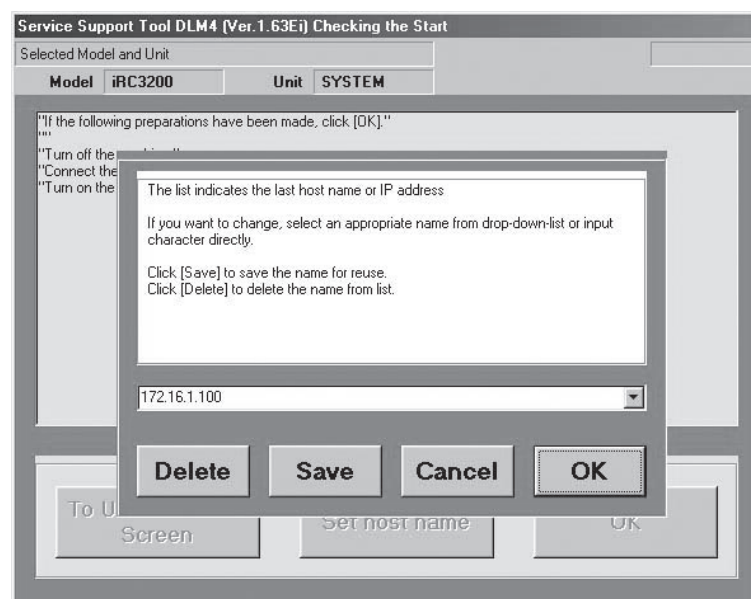

F06-402-04

5) Click [OK] to start making a connection.

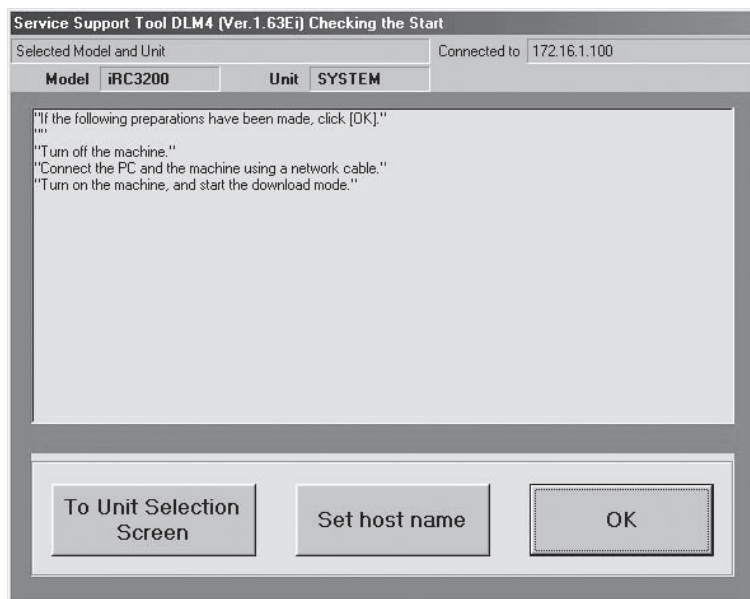

F06-402-05

6) When a connection has been made and the following screen has appeared, click [OK].

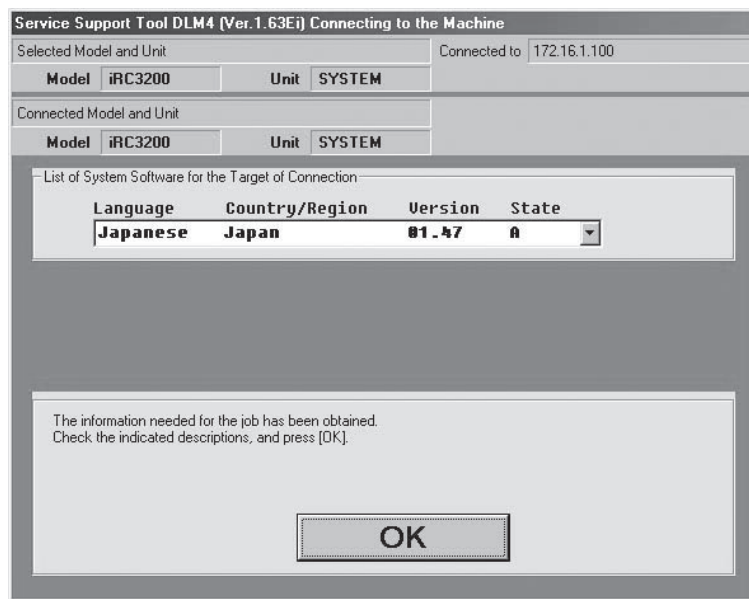

F06-402-06

7) Click [Upload the Backup Data].

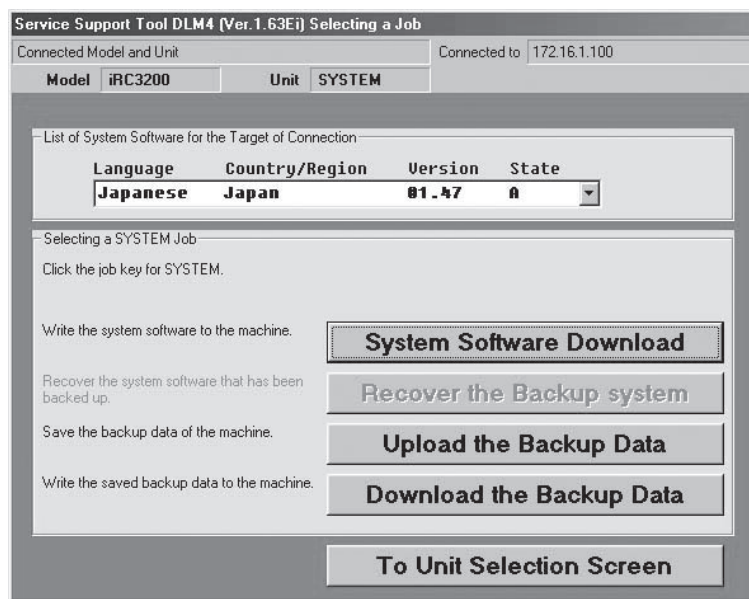

F06-402-07

8) Select the data to upload, and click [Start Storing].

SRAM PCB: SramImg.bin

DC controller PCB: SramDCON.bin

Reader controller PCB: SramRCON.bin

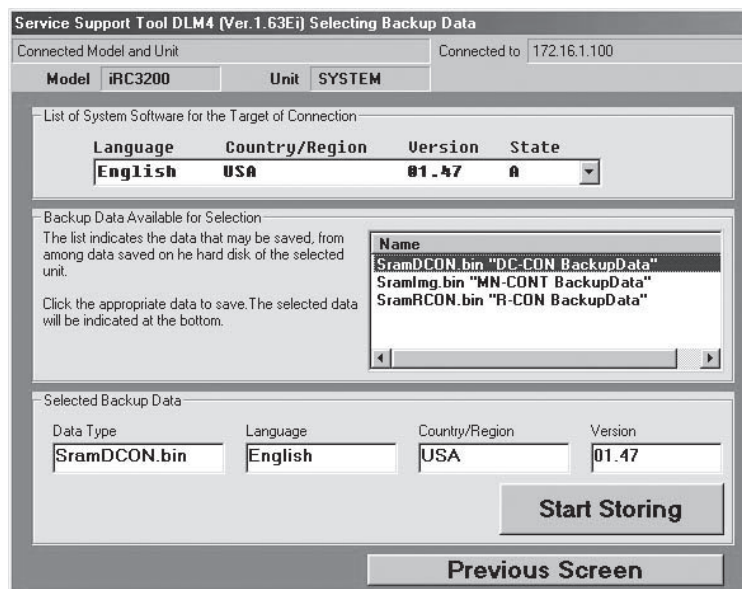

F06-402-08

9) When uploading has ended, enter a file name to use, and click [Save].

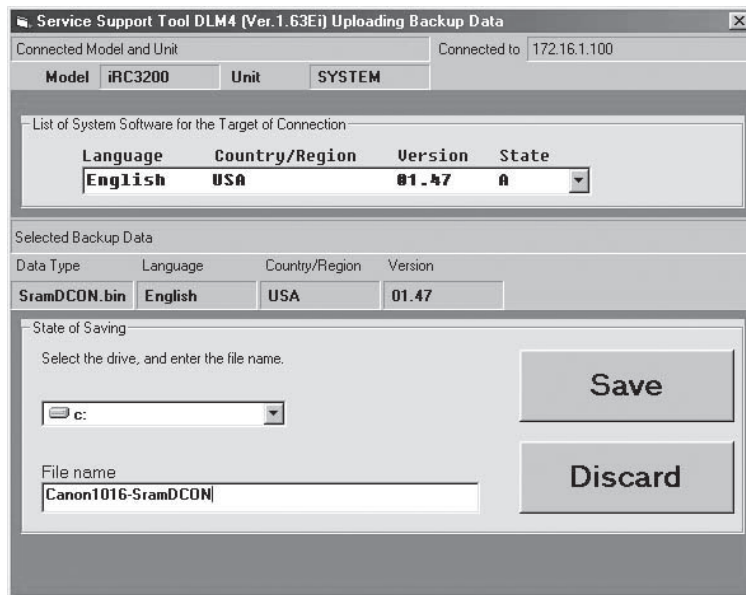

F06-402-09

10) When the file has been saved, click [OK].

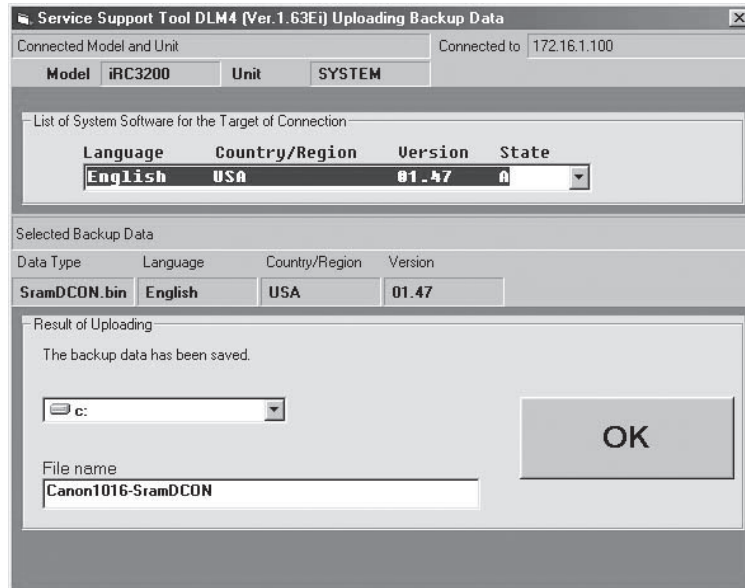

F06-402-10

11) Click [return to unit select screen].

4.3 Downloading Procedure

Procedure

Use normal mode to download.

- 1) Click [To Next] under 'Download/Upload'.

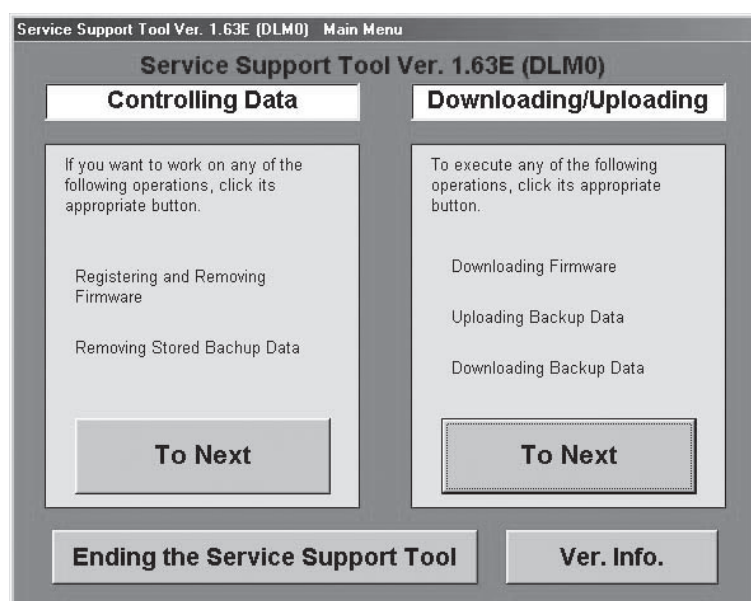

F06-403-01

- 2) Select 'SYSTEM' under 'iRC3200', and click [Connect].

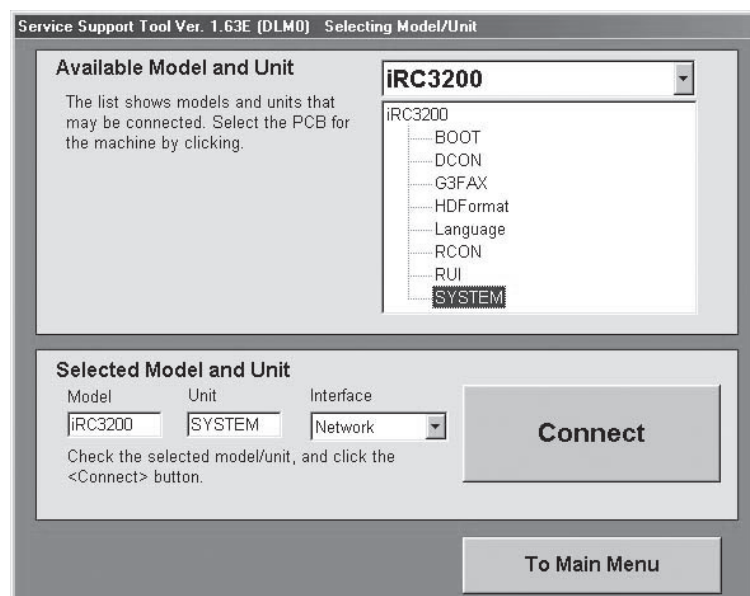

F06-403-02

3) Click [Set host name].

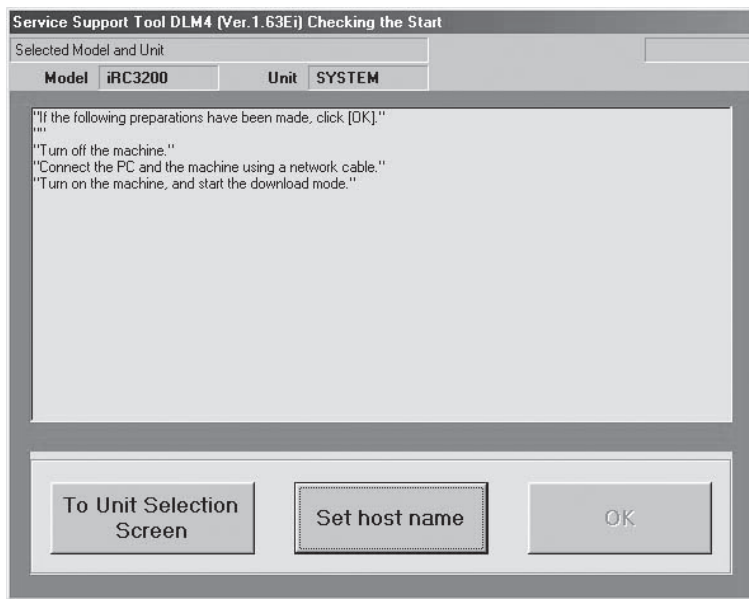

F06-403-03

4) The machine's IP address is entered automatically; click [OK].

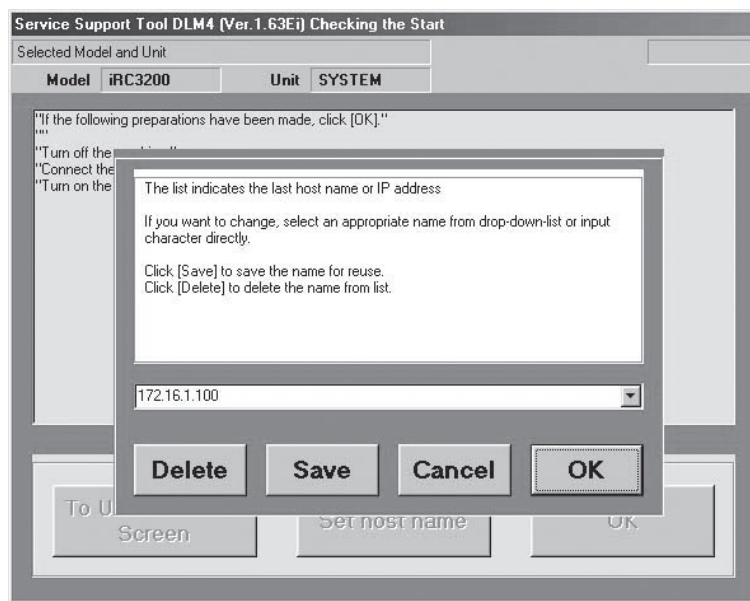

F06-403-04

- 5) Click [OK] to start a connection.

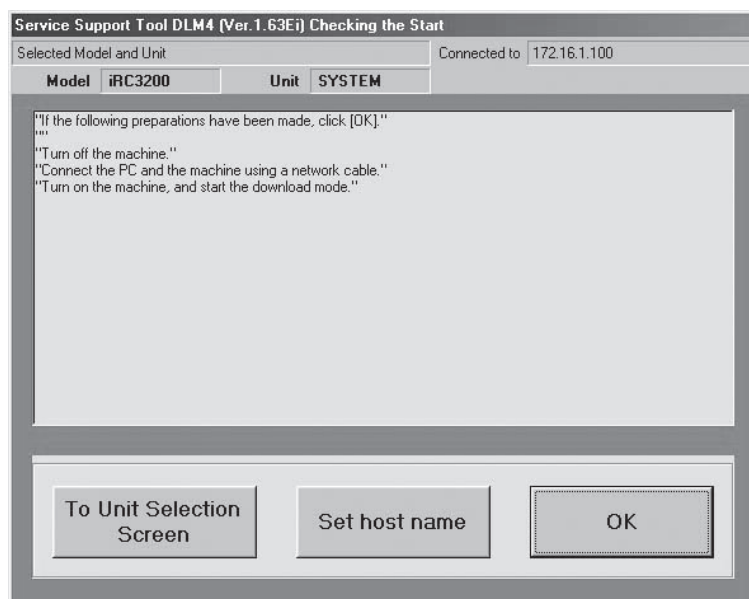

F06-403-05

- 6) When a connection has been made and the following screen has appeared, click [OK].

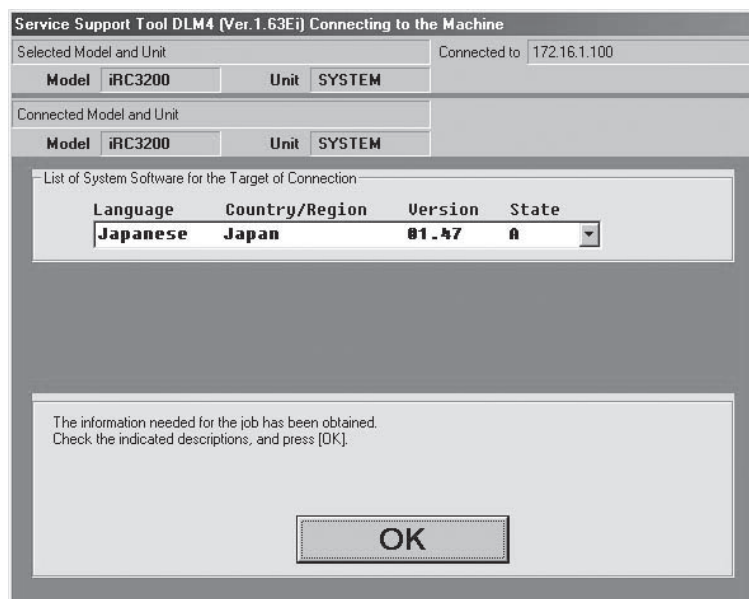

F06-403-06

7) Click [Download the Backup Data].

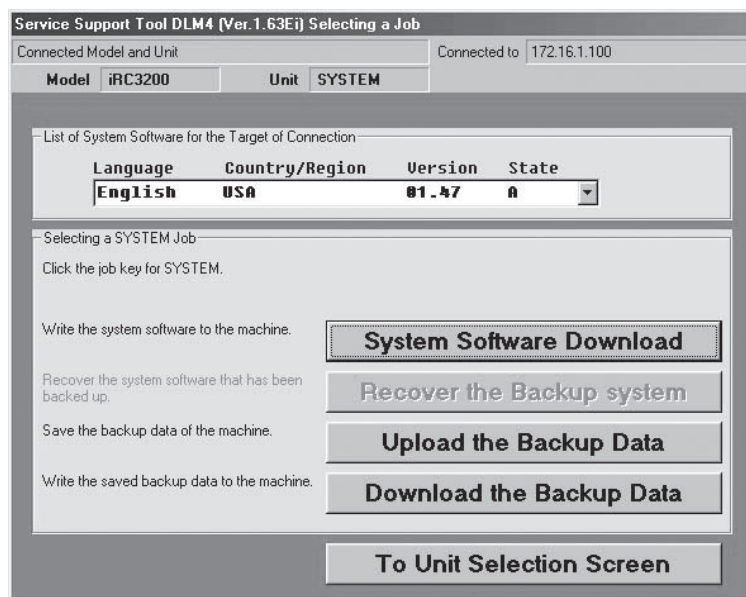

F06-403-07

8) Select the file to download, and click [Start Writing].

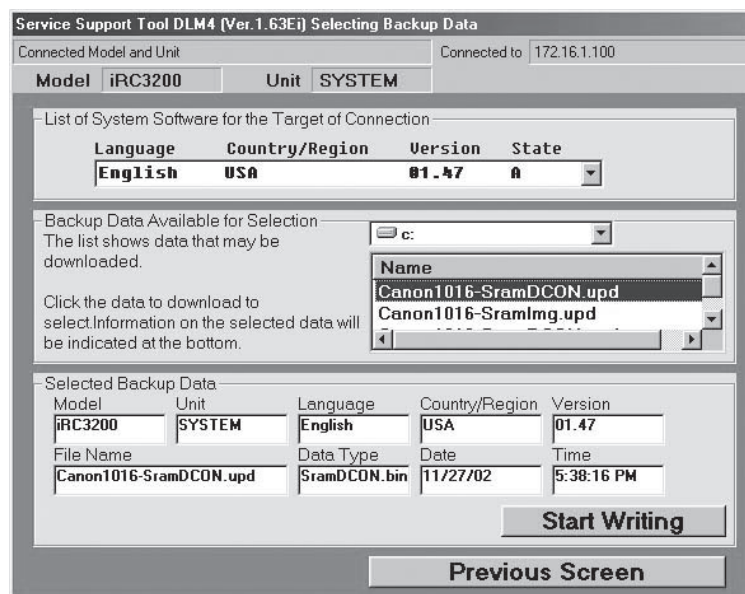

F06-403-08

9) When downloading has ended, click [OK].

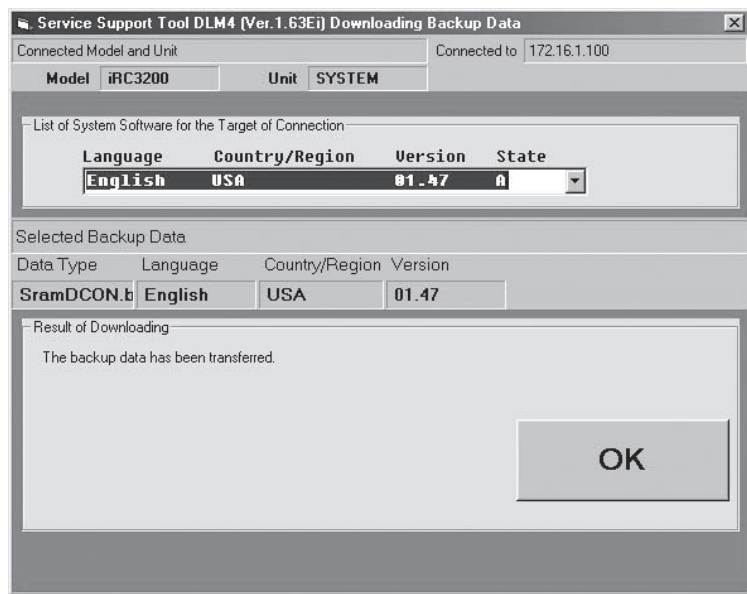

F06-403-09

10) Click [return to unit selection screen].

APPENDIX

1 General Timing Chart

1.1 Sequence of Operations (DADF, reader unit)

Full color, Monochrome (common), A4 original, Single-sided scan (3 sides, continuous)

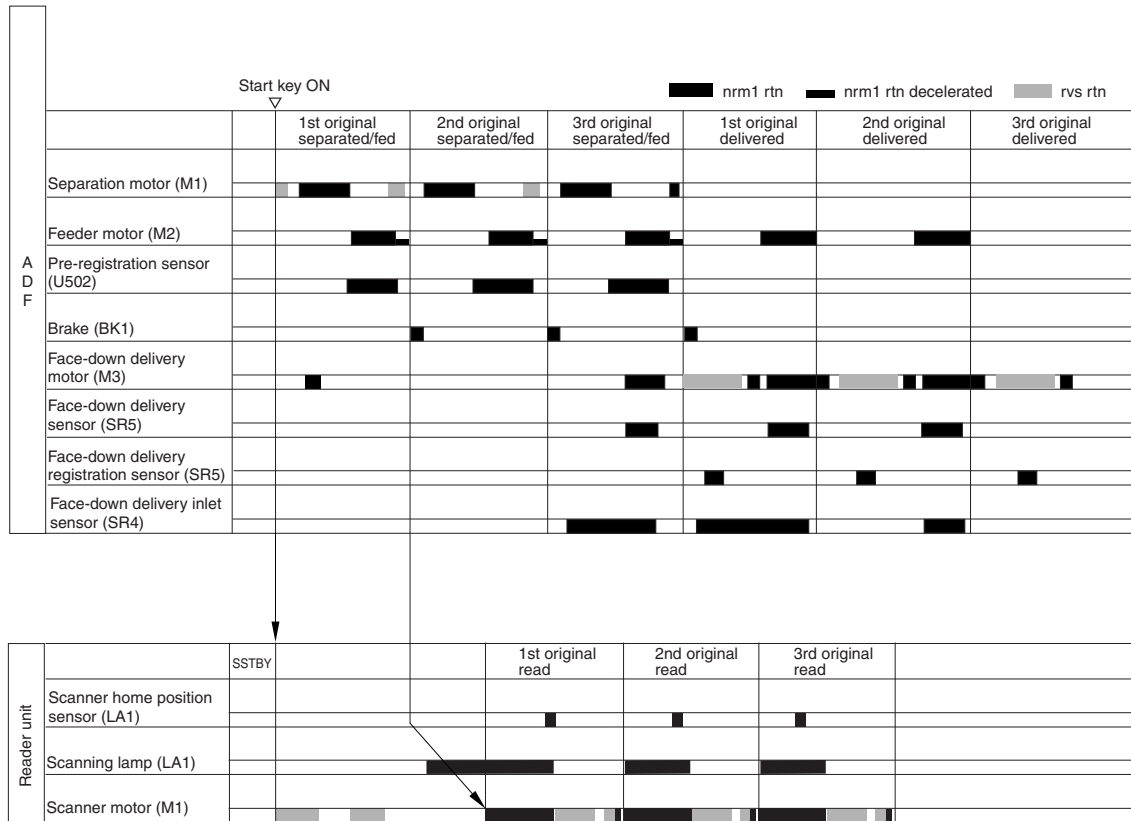

1.2 Sequence of Operations (printer unit)

Full color, Cassette 1, A4 Single-sided (2 prints, continuous)

Used to stabilize the rotation (3.5 sec)

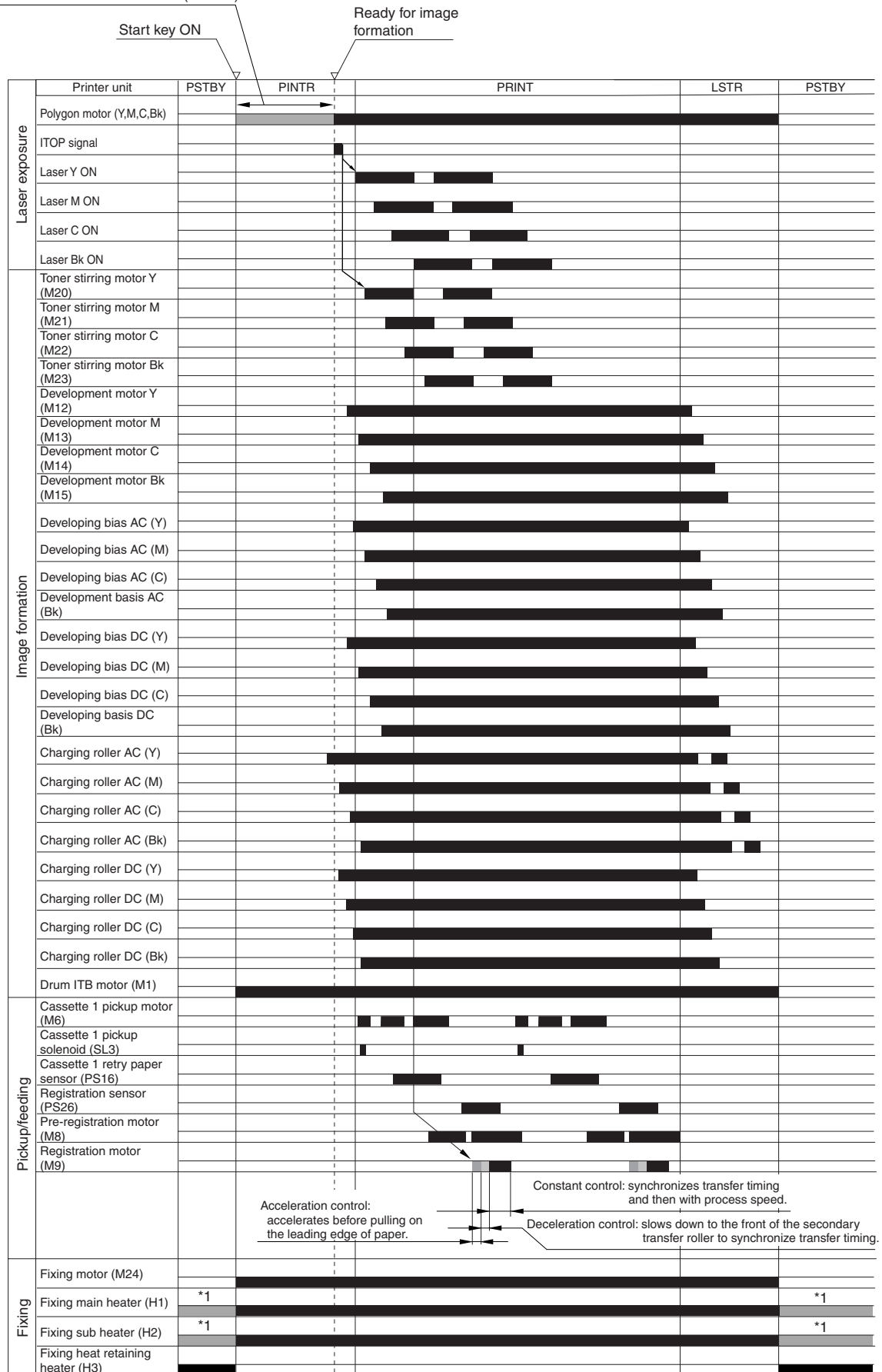

*1: The main heater or the sub heater is used for temperature control (to 190°C) according to the difference in reading by the main thermistor (TH1) and the sub thermistor (TH2).

2 Signal Names and Notations

2.1 Signal Names

A	LDE motor phase A
*ACC_CNCT	cassette pedestal controller PCB connection
*ACC_INT	transmission interrupt signal
*ACC_PRDY	cassette pedestal power ready
B LDE	motor phase B
*DRAM_MTR_ON	drum ITB motor ON/OFF signal
*DRUM_MTR_LOCK	drum ITB motor clock error
*DUP_CNCT	duplex PCB connection
PM_DEV_C_A	development motor phase A C
PM_DEV_C_B	development motor phase B C
PM_DEV_K_A	development motor phase A Bk
PM_DEV_K_B	development motor phase B Bk
PM_DEV_M_A	development motor phase A M
PM_DEV_M_B	development motor phase B M
PM_DEV_Y_A	development motor phase A Y
PM_DEV_Y_B	development motor phase B Y
PM_DUP_A	duplex motor phase A
PM_DUP_B	duplex motor phase B
*PM_DUP_I0	duplex motor current switchover 0
*PM_DUP_I1	duplex motor current switchover 1
PM_FEED1_A	cassette 1 pickup motor phase A
PM_FEED1_B	cassette 1 pickup motor phase B
PM_FEED2_A	cassette 2 pickup motor phase A
PM_FEED2_B	cassette 2 pickup motor phase B
PM_FJ_A	face-down delivery motor phase A
PM_FJ_B	face-down delivery motor phase B
PM_FUSER_A	fixing drive motor phase A
PM_FUSER_B	fixing drive motor phase B
PM_PREREGI_A	registration motor phase A
PM_PREREGI_B	registration motor phase B
PM_REGI_A	pre-registration motor phase A
PM_REGI_B	pre-registration motor phase B
PM_SIDE_REGI_A	horizontal registration motor phase A
*PM_SIDE_REGI_B	horizontal registration motor phase B
PM_VPASS_A	vertical path motor phase A
PM_VPASS_B	vertical path motor phase B
*SUB_HEATER_ON	heat retaining heater ON/OFF signal
ITR_CTRL_BK	primary transfer control Bk
ITR_CTRL_C	primary transfer control C

ITR_CTRL_M	primary transfer control M
ITR_CTRL_Y	primary transfer control Y
24V_ERR	24V power supply error signal
24V_ON	24V power supply ON/OFF signal
2TR_CTRL_N	secondary transfer negative bias output control
2TR_CTRL_P	secondary transfer positive bias output control
2TR_SEL	secondary transfer bias output positive/negative switchover
5 (J127-A9)	waste toner sensor LDE drive
A	LDE motor phase A
A-	motor phase A-
A+	motor phase A+
AC_I_SNS_C	charging AC current C
AC_I_SNS_K	charging AC current Bk
AC_I_SNS_M	charging AC current M
AC_I_SNS_Y	charging AC current Y
ACC_C	laser scanner motor acceleration control
ACC_CLK	machine communication I/F
ACC_CNECT	machine communication I/F
ACC_CPRDY	machine communication I/F
ACC_INT*	machine communication I/F
ACC_K	laser scanner motor acceleration control
ACC_M	laser scanner motor control
ACC_POWER_RL_ON	accessories power supply relay (GND side)
ACC_POWER_RL24V	accessories power supply relay (power supply side)
ACC_POWER_ON	machine communication I/F
ACC_PRDY	machine communication I/F
ACC_RXD	machine communication I/F
ACC_TXD	machine communication I/F
ACC_Y	laser scanner motor acceleration control
AP_ACLP*	analog processor ACLP
AP_MCLK	analog processor drive
AP_SCLK*	analog processor scanner lock communication
AP_SDATA*	analog processor scanner data
AP_SLOAD*	analog processor scanner load communication
ATR_CTRL_C	ATR sensor gain control C
ATR_CTRL_K	ATR sensor gain control Bk
ATR_CTRL_M	ATR sensor gain control M
ATR_CTRL_Y	ATR sensor gain control Y
ATR_SIG_C	ATR sensor C
ATR_SIG_K	ATR sensor Bk
ATR_SIG_M	ATR sensor M
ATR_SIG_Y	ATR sensor Y
AVD011	video signal

AVD012	video signal
AVD013	video signal
AVD014	video signal
B	LDE motor phase B
B-	motor phase B-
B+	motor phase B+
B0	video signal
B1	video signal
B2	video signal
B3	video signal
B4	video signal
B5	video signal
B6	video signal
B7	video signal
B8	video signal
B9	video signal
BKLTON	LCD ON/OFF signal
BR_DETECT	detection signal
BWUI_CK	not used
C_BD_N	C-BD detection
C_CTAL_<0>	laser drive 0
C_CTAL_<1>	laser drive 1
C_CTAL_<2>	laser drive 2
C_PBD	BD detection C
C_PDOUT	laser power motor
C_PHSYMC	horizontal sync signal C
C_PVD00	C data 0
C_PVD01	C data 1
C_PVD02	C data 2
C_PVD03	C data 3
C_PVRE0	video request C
C1_PAPER_SNS	cassette 2 paper detection
C1_PICK_RETERY_SNS	cassette 1 retry sensor
C1_PICK_UP_SL	cassette 1 pickup solenoid drive
C1_SIZE0	cassette 1 size detection 0
C1_SIZE1	cassette 1 size detection 1
C1_SIZE2	cassette 1 size detection 2
C1_SIZE3	cassette 1 size detection 3
C1_VOL_SNS_A	cassette 1 paper level sensor A
C1_VOL_SNS_B	cassette 1 paper level sensor B
C2_PAPER_SNS	cassette 2 paper detection
C2_PICK_RETERY_SNS	cassette 2 retry sensor
C2_PICK_UP_SL	cassette 2 pickup solenoid drive
C2_SIZE0	cassette 2 size detection 0

C2_SIZE1	cassette 2 size detection 1
C2_SIZE2	cassette 2 size detection 2
C2_SIZE3	cassette 2 size detection 3
C2_VOL_SNS_A	cassette 2 paper level sensor A
C2_VOL_SNS_B	cassette 2 paper level sensor B
C3_FEED_M_A	cassette 3 pickup motor phase A
C3_FEED_M_A*	cassette 3 pickup motor phase A*
C3_FEED_M_B	cassette 3 pickup motor phase B
C3_FEED_M_B*	cassette 3 pick motor phase B*
C3_PAPER_SNS	cassette 3 paper detection
C3_RETRY_SNS	cassette 3 retry sensor
C3_SIZE0	cassette 3 size detection 0
C3_SIZE1	cassette 3 size detection 1
C3_SIZE2	cassette 3 size detection 2
C3_SIZE3	cassette 3 size detection 3
C3_VOL_A	cassette 3 paper level A
C3_VOL_B	cassette 3 paper level B
C4_FEED_M_A	cassette 4 pickup motor phase A
C4_FEED_M_A*	cassette 4 pickup motor phase A*
C4_FEED_M_B	cassette 4 pickup motor phase B
C4_FEED_M_B*	cassette 4 pickup motor phase B*
C4_PAPER_SNS	cassette 4 paper detection
C4_PICKUP_SL	cassette 4 pickup solenoid drive
C4_RETRY_SNS	cassette 4 retry sensor
C4_SIZE0	cassette 4 size detection 0
C4_SIZE1	cassette 4 size detection 1
C4_SIZE2	cassette 4 size detection 2
C4_SIZE3	cassette 4 size detection 3
C4_VOL_A	cassette 4 paper level A
C4_VOL_B	cassette 4 paper level B
CA_PWM	laser A data differential positive output
CASET_HEATER_ON	cassette heater drive
CASET_HEATER_RL24V	cassette heater power supply 24 V
CASHEATER_RELAY_ON	cassette heater ON/OFF signal
CB_PWN	laser B data differential positive output
CCV_CNCTN2	pickup size output
CCV_CNT2	coin robot connection detection
CFL_ON	inverter drive power supply (+5 V)
CH_CLK	charging AC bias clock error
CHOUHI_CLK	2.5K deck communication I/F
CHRG_AC_CLK	charging AC bias clock error (after level conversion)
CHRG_AC_CTRL_C	charging AC bias control C
CHRG_AC_CTRL_C_SND	charging AC bias control C
CHRG_AC_CTRL_K	charging AC bias control Bk

CHRG_AC_CTRL_K_SND	charging AC bias control Bk
CHRG_AC_CTRL_M	charging AC bias control M
CHRG_AC_CTRL_M_SND	charging AC bias control M
CHRG_AC_CTRL_Y	charging AC bias control Y
CHRG_AC_CTRL_Y_SND	charging AC bias control Y
CHRG_DC_CTRL_C	charging DC bias control C
CHRG_DC_CTRL_K	charging DC bias control Bk
CHRG_DC_CTRL_M	charging DC bias control M
CHRG_DC_CTRL_Y	charging DC bias control Y
CHRG_OUT	charging bias output
CICNT	high-voltage incoming
CK1*	CCD No. 1 shift register drive
CK2*	CCD No. 2 shift register drive
CLEANER_FAN_ERR	cleaner fan rotation detection
CLEANER_FAN_ON_24V_/12V	cleaner fan drive
CLR*	CCD CLR gate drive
CNTP	delivery count
COIN_COUNT	delivery count
COIN_RXD	coin robot serial Rx
COIN_TXD	coin robot serial Tx
COM_C	LDE motor ON/OFF
COM_K	LDE motor ON/OFF
COM_M	LDE motor ON/OFF
COM_Y	LDE motor ON/OFF
CP	LCD data shift clock error
CRG_MEM_CA_ENB	internal memory circuit enable
CRG_MEM_CLK	internal memory data transfer CLK
CRG_MEM_DATA_IN R ×	internal memory data input
CRG_MEM_SEL_A	internal memory select signal A
CRG_MEM_SEL_B	internal memory select signal B
CRG_MEM_SEL_C	internal memory select signal C
CRG_MEM_START	internal memory data transfer start
CRG_MEM_STOP	internal memory data transfer stop
CRG_MEM_DATA_OUT T ×	internal memory data output
CROSS_PASS_SL	cross bus solenoid ON/OFF signal
CUI_CK	control panel connection detection bit
D0	LCD display data 0
D1	LCD display data 1
D2	LCD display data 2
D3	LCD display data 3
D4	LCD display data 4
D5	LCD display data 5
D6	LCD display data 6
D7	LCD display data 7

DATAA	motor phase A
DATAB	motor phase B
DCP_FAN_ERR	DC power supply fan error signal
DCP_FAN_FULL	power fan ON/OFF signal
DCP_FAN_HALF	power fan half-speed/full-speed switchover
DCP_RDY	stop warning signal (in response to drop in high voltage on primary side)
DDI_PVCLK	printer video clock error
DDICLK	scanner clock
DDIHSYNC*	scanner horizontal sync signal
DDIVSYNC*	scanner vertical sync signal
DEC_C	laser scanner motor deceleration control
DEC_K	laser scanner motor deceleration control
DEC_M	laser scanner motor deceleration control
DEC_Y	laser scanner motor deceleration control
DERIVERY_FAN_ERR	delivery cooling fan rotation detection
DERIVERY_FAN_ON_24V/12V	delivery cooling fan drive
DEV_AC_CLK1_C	developing AC bias clock error 1C
DEV_AC_CLK1_K	developing AC bias clock error 1Bk
DEV_AC_CLK1_M	developing AC bias clock error 1M
DEV_AC_CLK1_Y	developing AC bias clock error 1Y
DEV_AC_CLK2_C	developing AC bias clock error 2C
DEV_AC_CLK2_K	developing AC bias clock error 2Bk
DEV_AC_CLK2_M	developing AC bias clock error 2M
DEV_AC_CLK2_Y	developing AC bias clock error 2Y
DEV_AC_CTRLT_C	developing AC bias control ON/OFF signal C
DEV_AC_CTRLT_K	developing AC bias control ON/OFF signal Bk
DEV_AC_CTRLT_M	developing AC bias control ON/OFF signal M
DEV_AC_CTRLT_Y	developing AC bias control ON/OFF signal Y
DEV_CLK_A	developing AC bias clock error A
DEV_CLK_A_INV	developing AC bias clock error A (reversal)
DEV_CLK_B	developing AC bias clock error B
DEV_CLK_B_INV	developing AC bias clock error B (reversal)
DEV_CLK_C	developing AC bias clock error C
DEV_CLK_C_INV	developing AC bias clock error C (reversal)
DEV_DC_CTRL_C	developing DC clock bias control ON/OFF signal C
DEV_DC_CTRL_K	developing DC bias control ON/OFF signal Bk
DEV_DC_CTRL_M	developing DC bias control ON/OFF signal M
DEV_DC_CTRL_Y	developing DC bias control ON/OFF signal Y
DEV_MODE_C	developing AC bias wave form switchover C (WBP \leftrightarrow square)
DEV_MODE_K	developing AC bias wave form switchover Bk (WBP \leftrightarrow square)

DEV_MODE_M	developing AC bias wave form switchover M (WBP ⇔ square)
DEV_MODE_Y	developing AC bias wave form switchover Y (WBP ⇔ square)
DEV_OUT	developing bias output
DEV_VIN_C	developing AC bias power supply C
DEV_VIN_K	developing AC bias power supply Bk
DEV_VIN_M	developing AC bias power supply M
DEV_VIN_Y	developing AC bias power supply Y
DF_R × D	ADF communication Rx
DF_R × D	ADF communication Rx
DF_T × D	ADF communication Tx
DF_T × D*	ADF communication Tx
DISP	LCD display control
DP	not used
DRAM_MTR_CLK	drum ITB motor fault
DRAM_MTR_F/R*	drum ITB motor rotation direction switchover
DRAM_MTR_FG	drum ITB motor FG
DRAM_MTR_SPD0	drum ITB motor gain switchover
ECO_CS	ROM chip select
ECO_DIN	ECO-ID serial ROM D input (to ROM)
ECO_DOUT	ECD-ID serial ROM output (from ROM)
ECO_SCK	ROM serial clock error
ENV_HUM	environmental humidity
ENV_THM	environmental temperature
EXHAUST_FAN_ERR	heat discharge fan rotation detection
EXHAUST_FAN_ON_24V/12V	heat discharge fan drive
FAFDAT6	LCD display data 6
FAXRST-	fax forced reset
FBT_CLK	high-voltage DC bias clock error
FCID	incoming signal
FCP	CCD clamp
FD_DELI_SNS	face-down delivery sensor
FD_FU_SL	FD_FU solenoid drive
FD_FULL_SNS	face-down full detection
FJ_SNS	face-down delivery sensor detection
FOFFFK	off-hook detection
FOPT0	option bit 0
FOPT1	option bit 1
FOPT2	option bit 2
FPDAT1	LCD display data 1
FPDAT3	LCD display data 3
FPDAT5	LCD display data 5
FPDAT7	LCD display data 7

FPFDAT0	LCD display data 0
FPFDAT2	LCD display data 2
FPFDAT4	LCD display data 4
FPFRAME	frame pulse
FPLINE	line pulse
FPSHIFT	shift clock error pulse
FR_DETECT	detection signal
FRM	LCD frame initialization
FRONT_DOOR_SNS	front cover open/closed detection
FRONT_OHP_SNS	transparency detection signal (front)
FRS	CCD reset gate drive
FUSER_DELI_SNS	fixing delivery sensor
FUSER_DERI_OPEN_SNS	fixing unit open/closed detection
FUSER_ENTER_SNS	fixing inlet sensor
FUSER_FAN_ERR	fixing heat discharge fan error
FUSER_FAN_ON_24V/12V	fixing heat discharge fan ON/OFF signal
FUSER_RELAY_ON	fixing relay ON/OFF signal
G0	video signal
G1	video signal
G2	video signal
G3	video signal
G4	video signal
G5	video signal
G6	video signal
G7	video signal
G8	video signal
G9	video signal
GPVCC2	active filter circuit return line
GVI DC1	return line to DCP2
H1_ON	main heater ON/OFF signal
H2_ON	sub heater ON/OFF signal
HDPWRON	not used
HOT	anti-condensation heater active
HP	home position
HRLY_ON	fixing relay ON/OFF signal
HV_DC_CLK	high-voltage bias clock error (after level conversion)
HVAC	common AC bias high voltage
HVT_ENB	high voltage enable
I_1TR_BK	primary transfer current detection Bk
I_1TR_C	primary transfer current detection C
I_1TR_M	primary transfer current detection M
I_1TR_Y	primary transfer current detection Y
I_2TR	secondary transfer current detection
I_CHRG_C	charging AC current detection C

I_CHRG_K	charging AC current detection Bk
I_CHRG_M	charging AC current detection M
I_CHRG_Y	charging AC current detection Y
I_TR1_C	primary transfer current detection C
I_TR1_K	primary transfer current detection Bk
I_TR1_Y	primary transfer current detection Y
I_TR1_M	primary transfer current detection M
IOACK	response (Centronics)
IOAUTOFD-	pickup (Centronics)
IOBSY	busy (Centronics)
IOFAULT	fault (Centronics)
IOINIT-	initialization (Centronics)
IOPD0	data bit 0 (Centronics)
IOPD1	data bit 1 (Centronics)
IOPD2	data bit 2 (Centronics)
IOPD3	data bit 3 (Centronics)
IOPD4	data bit 4 (Centronics)
IOPD5	data bit 5 (Centronics)
IOPD6	data bit 6 (Centronics)
IOPD7	data bit 7 (Centronics)
IOPDB-	strobe (Centronics)
IOPE	no paper (Centronics)
IOSEL	select state (Centronics)
IOSELIN-	select command (Centronics)
ISNS	secondary transfer current detection
K_BD_N	K-BD detection
K_CTAL_<0>	laser drive 0
K_CTAL_<1>	laser drive 1
K_CTAL_<2>	laser drive 2
K_PBD	BD detection
K_PDOUT	laser power motor
K_PHSYMC	horizontal sync signal Bk
K_PVD00	Bk data 0
K_PVD01	Bk data 1
K_PVD02	Bk data 2
K_PVD03	Bk data 3
K_PVREO	vide request Bk
KA_PWM	laser A data differential positive output
KB_PWN	laser B data differential positive output
K-DGT0	key scan output 0
K-DGT1	key scan output 1
K-DGT2	key scan output 2
K-DGT3	key scan output 3
K-DGT4	key scan output 4

K-DGT5	key scan output 5
K-DGT6	key scan output 6
K-DGT7	key scan output 7
K-RTN0	key data input 0
K-RTN1	key data input 1
K-RTN2	key data input 2
K-RTN7	key data input 7
LAMP-CONTROL	lamp ON
LCDPWR	LCD power supply control output
L-DGT0	LED scan output 0
L-DGT1	LED scan output 1
L-DGT2	LED scan output 2
L-DGT3	LED scan output 3
LED_SW	LED ON
LEFT_UP_DOOR_SNS	left upper cover open/closed detection
LO_VOL_IRQ	not used
LOAD	LCD latch
L-RTN0	LED data output 0
L-RTN2	LED data output 2
M_BD_N	M-BD detection
M_CTAL_<0>	laser drive 0
M_CTAL_<1>	laser drive 1
M_CTAL_<2>	laser drive 2
M_PBD	BD detection M
M_PDOUT	laser power motor
M_PHSYMC	horizontal sync signal M
M_PVD00	M data 0
M_PVD01	M data 1
M_PVD02	M data 2
M_PVD03	M data 3
M_PVREO	video request M
MA_PWM	laser A data differential positive output
MAIN_FUSER_THM1	main thermistor film temperature detection
MAIN_FUSER_THM2	main thermistor case temperature detection
MAIN_HEATER1_ON	main heater ON/OFF signal
MAIN_HEATER2_ON	sub heater ON/OFF signal
MB_PWN	laser B data differential positive output
MF_LAST_PARET_SNS	manual feed last paper detection
MF_PAPER_SNS	manual feed pickup paper detection
MF_PAPER_WIDTH	manual feed paper width detection
MF_PICKUP_SL	manual feed pickup solenoid drive
MODEL_DETECT	model identification
N. C	not used
N.C (CLKCTL)	not used

N.C (ESSACT)	not used
N.C (FSPOUT)	not used
N.C (RESERVED)	not used
NC	not used
NCTL	secondary transfer negative control
NEU TRAL	anti-condensation heater neutral
NL	DCP2 start-up power supply
OHP_LED_ON	transparency detection LEDON signal (front)
OHP_LED_ON	transparency detection LEDON signal (rear)
OMCLK	motor OMCLK
PATCH_P	SALT sensor detection 2
PATCH_REF	reference
PATCH_S	SALT sensor detention 1
PC_R × D	PC communication Rx
PC_T × D	PC communication Tx
PCMD	serial command
PCPRDY	controller ready
PCTL	secondary transfer positive control
PCTS	transmission clear
PDL_FAN_ERR	fan error signal
PDL_FAN_ON	fan ON signal
PLATEN	copyboard cover open/closed detection
PLATEN2	not used
PM_DEV_C_A	development motor phase A C
PM_DEV_C_B	development motor phase B C
PM_DEV_K_A	development motor phase A Bk
PM_DEV_K_B	development motor phase B Bk
PM_DEV_M_A	development motor phase A M
PM_DEV_M_B	development motor phase B M
PM_DEV_Y_A	development motor phase A Y
PM_DEV_Y_B	development motor phase B Y
PM_DUP_A	duplex motor phase A
PM_DUP_B	duplex motor phase B
PM_FEED_A	cassette 2 pickup motor phase A
PM_FEED1_A	cassette 1 pickup motor phase A
PM_FEED1_B	cassette 1 pickup motor phase B
PM_FEED2_B	cassette 2 pickup motor phase B
PM_FJ_A	face-down delivery motor phase A
PM_FJ_B	face-down delivery motor phase B
PM_FUSER_A	fixing drive motor phase A
PM_FUSER_B	fixing drive motor phase B
PM_PREREGL_A	pre-registration motor phase A
PM_PREREGL_B	pre-registration motor phase B
PM_REGI_A	registration motor phase A

PM_REGI_B	registration motor phase B
PM_SIDE_REG_ENB	horizontal motor enable
PM_SIDE_REG_VDOWN	horizontal motor voltage
PM_SIDE_REGI_A	horizontal motor phase A
PM_SIDE_REGI_B	horizontal motor phase B*
PM_SIDE_REGI_COM	horizontal registration motor GND
PM_VPASS_A	vertical path motor phase A
PM_VPASS_B	vertical path motor phase B
PPIC0	general input (not used)
PPIC1	general input (not used)
PPIC2	general input (not used)
PPOC0	general output (not used)
PPOC1	general output (not used)
PPOC2	general output (not used)
PPOWER	power ON
PPRDY	power supply ready
PPRTST	print start
PRE_REGI_CL	pre-registration clutch ON/OFF signal
PRE_REGI_SNS	pre-registration sensor
PRTS	transmission request
PSCNST	read start
PSEL	secondary transfer positive/negative switchover
PSTS	serial status
PVCC2	active filter circuit control paper supply
PWAKE	printer non-all night
R_LED_ON	registration detection LED drive
R_RESET	peak hold circuit reset signal
R0	video signal
R1	video signal
R2	video signal
R3	video signal
R4	video signal
R5	video signal
R6	video signal
R7	video signal
R8	video signal
R9	video signal
REAR_OHP_SNS	transparency detection signal (rear)
REFEED_CL	re-pickup clutch ON/OFF signal
REFEED_SNS	re-pickup sensor
REGI_MF_OPEN_SNS	registration manual feed open/closed detection
REGI_SNS	registration sensor signal
REGIMULTI_FAN_ERR	registration manual feed fan rotation detection
REGIMULTI_FAN_ON	registration manual feed fan drive

REM_ON1	supply power control signal 1
REST	reset (H reset)
RXD	ASSIST serial Rx
RXD*	serial Rx
RXDATA	2.5K deck communication I/F
RXEND	2.5K deck communication I/F
RXOUTEN	2.5K deck communication I/F
SCMD	scanner serial command
SCPRDY*	scanner communication I/F
SCT*	scanner ready for reception
SDOWNLOAD*	scanner download
SH1*	CCD SH1 gate drive
SH2*	CCD SH2 gate drive
SH3*	CCD SH3 gate drive
SIDE_REGI_SNS	horizontal registration sensor
SIPC_RXD	finisher communication I/F
SIPC_TXD	finisher communication I/F
SIZE1	AB original size detection
SIZE2	inch original size detection
SLIVEWAKE*	reader start-up (no initial operation)
SOFTSW*	soft switch
SOFTSWC-IP	soft switch
SPRDY*	scanner communication I/F
SRTS*	reader ready for reception
SSTS	scanner serial status
ST1*	CCD ST1 gate drive
ST2*	CCD ST2 gate drive
ST3*	CCD ST3 gate drive
ST4*	CCD ST4 gate drive
STROBE	motor drive signal latch
SUB_FUSER_THM	sub thermistor detection
SUB_LO_CTRL_C	downstream auxiliary bias control C
SUB_LO_CTRL_K	downstream auxiliary bias control Bk
SUB_LO_CTRL_M	downstream auxiliary bias control M
SUB_LO_CTRL_Y	downstream auxiliary bias control Y
SUB_LO_DC_CTRL_C	downstream auxiliary DC bias control C
SUB_LO_DC_CTRL_K	downstream auxiliary DC bias control Bk
SUB_LO_DC_CTRL_M	downstream auxiliary DC bias control M
SUB_LO_DC_CTRL_Y	downstream auxiliary DC bias control Y
SUB_LOWER_OUT	downstream bias output
SUB_UP_AC_CTRL_C	upstream bias AC bias control C
SUB_UP_AC_CTRL_K	upstream bias AC bias control Bk
SUB_UP_AC_CTRL_M	upstream bias AC bias control M
SUB_UP_AC_CTRL_Y	upstream bias AC bias control Y

SUB_UP_DC_CTRL_C	upstream bias DC bias control C
SUB_UP_DC_CTRL_K	upstream bias DC bias control Bk
SUB_UP_DC_CTRL_M	upstream bias DC bias control M
SUB_UP_DC_CTRL_Y	upstream bias DC bias control Y
SUB_UPPER_C	upstream auxiliary bias high voltage C
SUB_UPPER_K	upstream auxiliary bias high voltage Bk
SUB_UPPER_M	upstream auxiliary bias high voltage M
SUB_UPPER_OUT	upstream auxiliary bias high voltage
SUB_UPPER_Y	upstream auxiliary bias high voltage Y
SVD00	video signal
SVD01	video signal
SVD010	video signal
SVD015	video signal
SVD016	video signal
SVD017	video signal
SVD018	video signal
SVD019	video signal
SVD02	video signal
SVD020	video signal
SVD021	video signal
SVD022	video signal
SVD023	video signal
SVD03	video signal
SVD04	video signal
SVD05	video signal
SVD06	video signal
SVD07	video signal
SVD08	video signal
SVD09	video signal
SW1	CCD SW1 gate drive
SW2	CCD SW2 gate drive
SW3	CCD SW3 gate drive
TCRG_ON_C	toner container motor drive C
TCRG_ON_K	toner container motor drive Bk
TCRG_ON_M	toner container motor drive M
TCRG_ON_Y	toner container motor drive Y
TCRG_PULSE_C	toner container rotation detection C
TCRG_PULSE_K	toner container rotation detection Bk
TCRG_PULSE_M	toner container rotation detection M
TCRG_PULSE_Y	toner container rotation detection Y
TEST	shipment inspection test terminal
TG1*	CCD TG1 gate drive
TG2*	CCD TG2 gate drive
TG3*	CCD TG3 gate drive

TG4*	CCD TG4 gate drive
to_CP28	threshold level monitor signal
to_CP29	threshold level monitor
TR_ERR*	triac error detection
TR1_CTRL_C	primary transfer control C
TR1_CTRL_K	primary transfer control Bk
TR1_CTRL_M	primary transfer control M
TR1_CTRL_Y	primary transfer control Y
TR1_OUT_C	primary transfer bias output C
TR1_OUT_K	primary transfer bias output Bk
TR1_OUT_M	primary transfer bias output M
TR1_OUT_Y	primary transfer basis output Y
TTP-D	touch panel control input/output (down)
TTP-L	touch panel control input/output (left)
TTP-R	touch panel control input/output (right)
TTP-U	touch panel control input/output (up)
TXD	ASSIST serial Tx
TXD*	serial Tx
TXLOAD	2.5K deck communication I/F
VINDC1	DC power supply source for DCP2
VLCD	LCD contrast adjustment voltage
VPASS_FAN_ERR	vertical path fan error
VPASS_FAN_ON	vertical path fan ON
VPASS_OPEN_SNS	pickup vertical path cover open/closed detection
VREF	motor drive current setting
WASTE_TONER_FULL	waste toner sensor drive
XCA_PWM	laser A data differential negative output
XCB_PWN	laser B data differential negative output
XKA_PWM	laser A data differential negative output
XKB_PWN	laser B data differential negative output
XMA_PWM	laser A data differential negative output
XMB_PWN	laser B data differential negative output
XSYNC	lamp sync control
XTDATA	2.5K deck communication I/F
XYA_PWM	laser A data differential negative output
XYB_PWN	laser B data differential negative output
Y_BD_N	Y-BD detection
Y_CTAL_<0>	laser drive 0
Y_CTAL_<1>	laser drive 1
Y_CTAL_<2>	laser drive 2
Y_PBD	BD detection Y
Y_PDOUT	laser power motor
Y_PHSYNC	horizontal sync signal Y
Y_PVD00	Y data 0

Y_PVD01	Y data 1
Y_PVD02	Y data 2
Y_PVD03	Y data 3
Y_PVRE0	video request Y
YA_PWM	laser A data differential positive output
YB_PWN	laser B data differential positive output
Z_CRS	not used (formerly, zero-cross detection signal)

3 General Circuit Diagram

3.1 Names of Electrical Parts

Notation	Name	Location	Notation	Name	Location
CBS1	circuit breaker	B-12-i	PS1	toner feedscrew rotation sensor (Y)	F-3-b
CBS2	circuit breaker	B-12-i	PS2	toner feedscrew rotation sensor (M)	F-2-b
			PS3	toner feedscrew rotation sensor (C)	F-1-b
CF1	original size sensor	A-4-b	PS4	toner feedscrew rotation sensor (Bk)	F-1-b
CF2	original size sensor	A-2-b	PS5	fixing feeder unit open/closed sensor	J-4-d
			PS6	face-down delivery sensor 2	J-3-b
CL1	duplex registration clutch	G-13-a	PS7	cassette 1 paper sensor	G-3-f
CL2	duplex pickup clutch	G-12-a	PS8	center delivery tray full sensor	J-3-b
			PS9	manual feed last paper sensor	J-13-b
DLT51	AC supply to PS Print Server Unit-C1	B-10-g	PS10	manual feed paper sensor	J-11-b
DLT52	AC supply to Side Paper Deck-PI	B-11-g	PS11	pickup vertical path cover open/closed sensor	J-11-f
DLT53	AC supply to anti-condensation heater	B-9-g	PS12	face-down delivery sensor 1	J-2-b
			PS13	delivery vertical path cover open/closed sensor	J-2-b
ELCB1	leakage breaker	C-11-i	PS14	cassette 1 paper level sensor (A)	G-4-f
			PS15	cassette 1 paper level sensor (B)	G-4-f
EV1	environment sensor	E-8-b	PS16	cassette 1 retry paper sensor	G-4-f
			PS17	cassette 2 retry paper sensor	G-2-f
FM1	power supply cooling fan	I-9-e	PS18	cassette 2 paper level sensor (B)	G-2-f
FM2	fixing heat discharge fan	I-3-e	PS19	cassette 2 paper sensor	G-1-f
FM3	machine heat discharge fan	E-5-c	PS20	cassette 2 paper level sensor (A)	G-1-f
FM4	cleaner fan	J-6-c	PS21	duplex registration sensor	G-13-a
FM5	delivery cooling fan	G-8-f	PS22	duplex horizontal registration sensor	G-9-a
FM6	manual feed cooling fan	G-9-f	PS23	front cover open/closed sensor	E-6-c
FM7	controller fan	D-6-b	PS24	duplex pickup sensor	G-8-e
FM8	delivery vertical path heat discharge fan	I-4-c	PS25	fixing delivery sensor	I-13-b
			PS26	registration sensor	J-8-b
H1	anti-condensation heater	A-11-i	PS27	fixing inlet sensor	I-12-b
H1	fixing main heater	I-7-c	PS28	manual feed unit open/close sensor	E-4-b
H2	anti-condensation heater	A-10-i	PS51	cassette 3 paper level sensor (A)	B-10-a
H2	fixing sub heater	I-7-b	PS52	cassette 3 paper level sensor (B)	B-11-a
H3	fixing heat retaining heater	I-7-a	PS53	cassette 3 retry paper sensor	B-12-a
			PS54	cassette 3 paper sensor	B-10-a
LA1	scanning lamp	A-13-a	PS55	cassette 4 paper level sensor (A)	B-7-a
			PS56	cassette 4 paper level sensor (B)	B-7-a
M1	drum ITB motor	A-5-h	PS57	cassette 4 retry paper sensor	B-8-a
		C-5-h	PS58	cassette 4 paper sensor	B-6-a
		I-1-e	PS59	right cover open/closed sensor	B-3-d
M2	laser scanner motor (Y)	F-1-h			
M3	laser scanner motor (M)	F-12-h	SL1	manual feed pickup solenoid	J-9-b
M4	laser scanner motor (C)	F-10-h	SL2	delivery path switching solenoid	J-5-c
M5	laser scanner motor (Bk)	F-9-h	SL3	cassette 1 pickup solenoid	G-5-f
M6	cassette 1 pickup motor	G-8-f	SL4	cassette 2 pickup solenoid	G-2-f
M7	cassette 2 pickup motor	G-7-f	SL5	delivery path switching solenoid	G-12-a
M8	pre-registration motor	J-9-b			
M9	registration motor	J-11-b	SLS1	cassette 3 pickup solenoid	B-12-a
M10	delivery vertical path motor	J-2-c	SLS2	cassette 4 pickup solenoid	B-9-a
M11	face-down delivery motor	J-1-c			
M12	development motor (Y)	F-8-d	SP1	speaker	D-3-b
M13	development motor (M)	F-8-d			
M14	development motor (C)	F-7-d	SR1	copyboard cover open/closed sensor	A-10-g
M15	development motor (Bk)	F-7-d	SR2	home position sensor	A-10-g
M16	image slope correction motor (Y)	F-12-h			
M17	image slope correction motor (M)	F-11-h	SW1		C-13-g
M18	image slope correction motor (C)	F-10-h	SW2	cassette 1 size detecting switch	G-5-d
M19	image slope correction motor (Bk)	F-8-h	SW3	cassette 2 size detecting switch	G-6-d
M20	toner container motor (Y)	F-4-b	SW51	cassette 3 size detecting switch	B-2-b
M21	toner container motor (M)	F-3-b	SW52	cassette 4 size detecting switch	B-1-b
M22	toner container motor (C)	F-2-b	SW53	cassette heater switch	B-13-g
M23	toner container motor (Bk)	F-1-b			C-13-c
M24	fixing motor	I-2-e	SW53U	cassette heater switch	B-12-e
M25	horizontal registration motor	G-10-a			C-13-c
M26	duplex feeder motor	G-11-a			
M51	cassette 3 pickup motor	B-5-c	TH1	fixing main thermistor	I-10-b
M52	cassette 4 pickup motor	B-5-c	TH2	fixing sub thermistor	I-11-b
MSW1	front cover open/closed switch 1	C-7-b	TP1	fixing thermal switch	I-7-c
MSW2	front cover open/closed switch 2	C-7-a			
MSW3	manual feed unit open/closed switch 1	C-7-b	TPS1	SALT sensor	E-7-b
MSW4	manual feed unit open/closed switch 2	C-7-a			
MSW5	fixing feeder unit open/closed switch 1	C-8-b	TS1	ATR sensor (Y)	F-8-b
MSW6	fixing feeder unit open/closed switch 2	C-8-a	TS2	ATR sensor (M)	F-7-b
			TS3	ATR sensor (C)	F-7-b
OHP1	transparency sensor (front)	J-8-b	TS4	ATR sensor (Bk)	F-5-b
OHP2	transparency sensor (rear)	J-7-b			
			VRS51	varistor	H-2-b

A. Reader Unit Circuit Diagram (1/10)

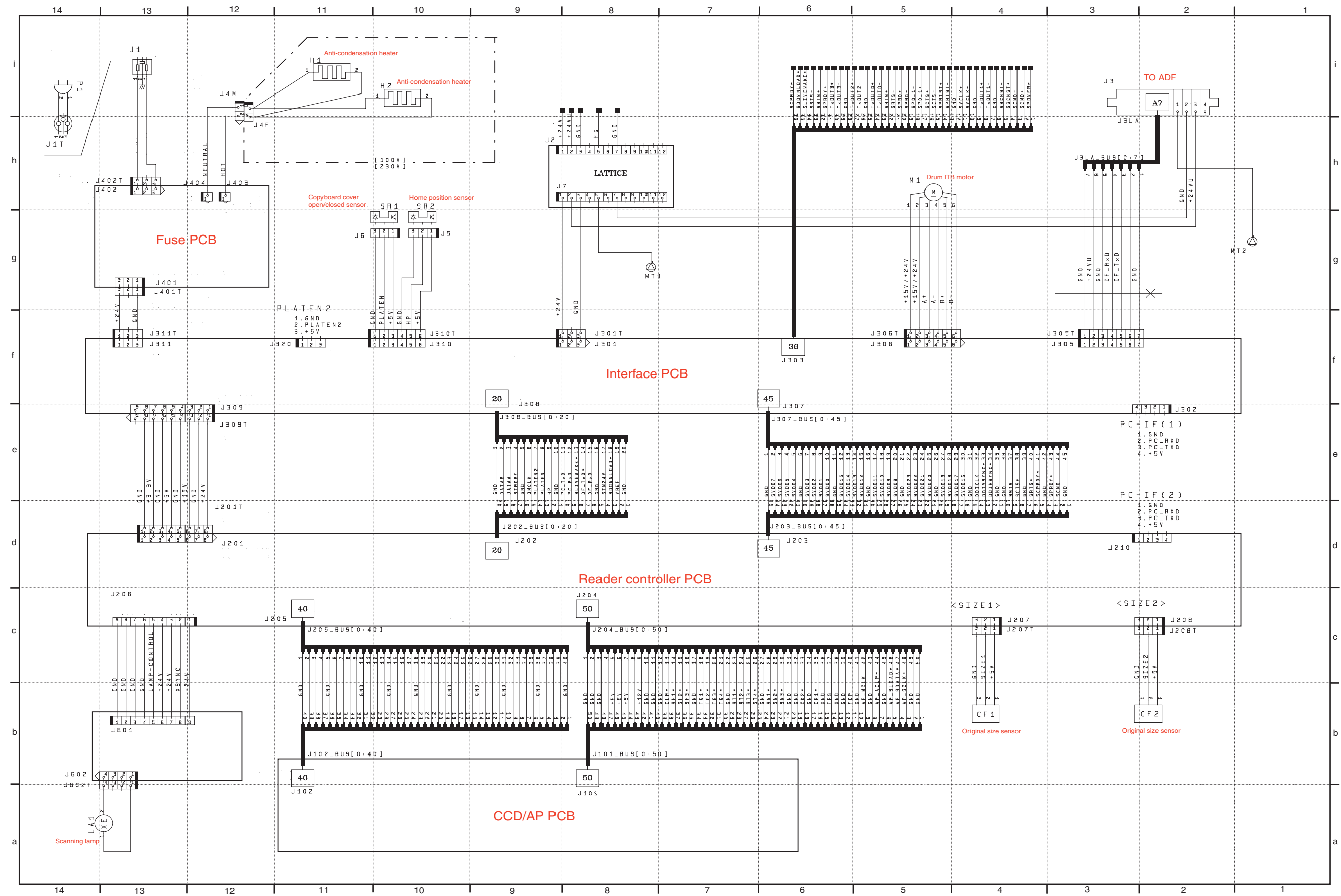

C. Power Supply Circuit Diagram (3/10)

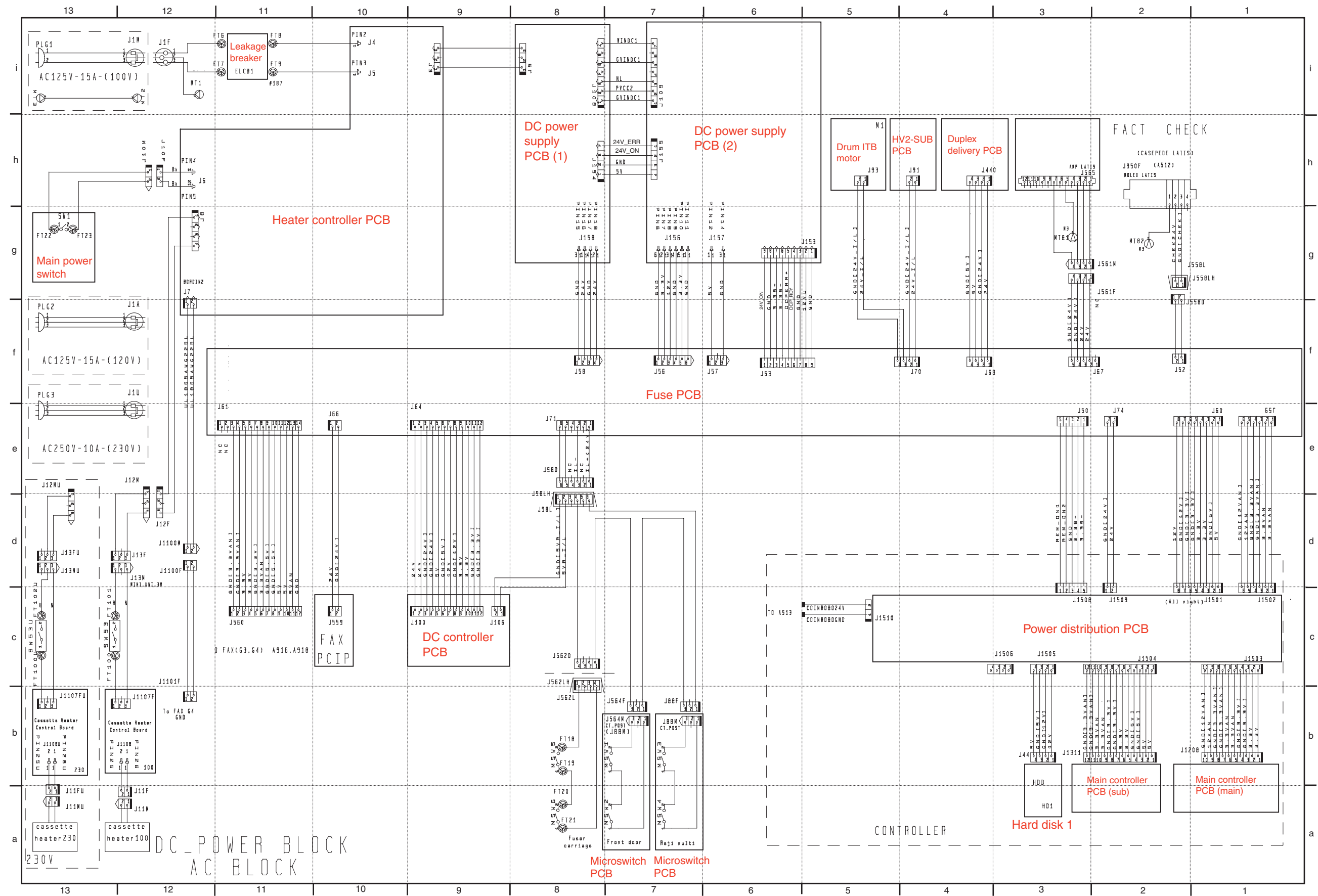

F. Laser Exposure System/Development System Circuit Diagram (6/10)

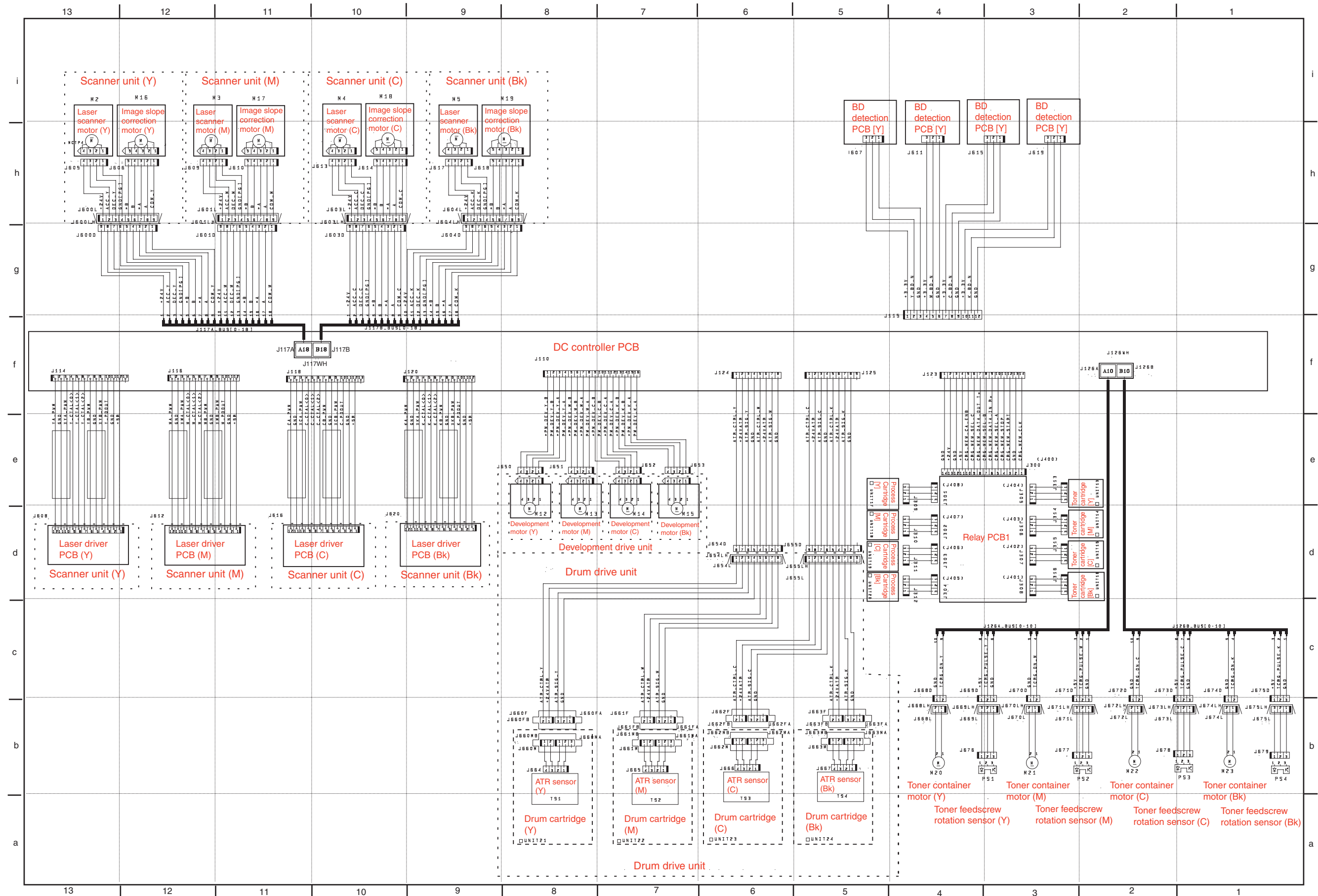

G. Pickup System Circuit Diagram (7/10)

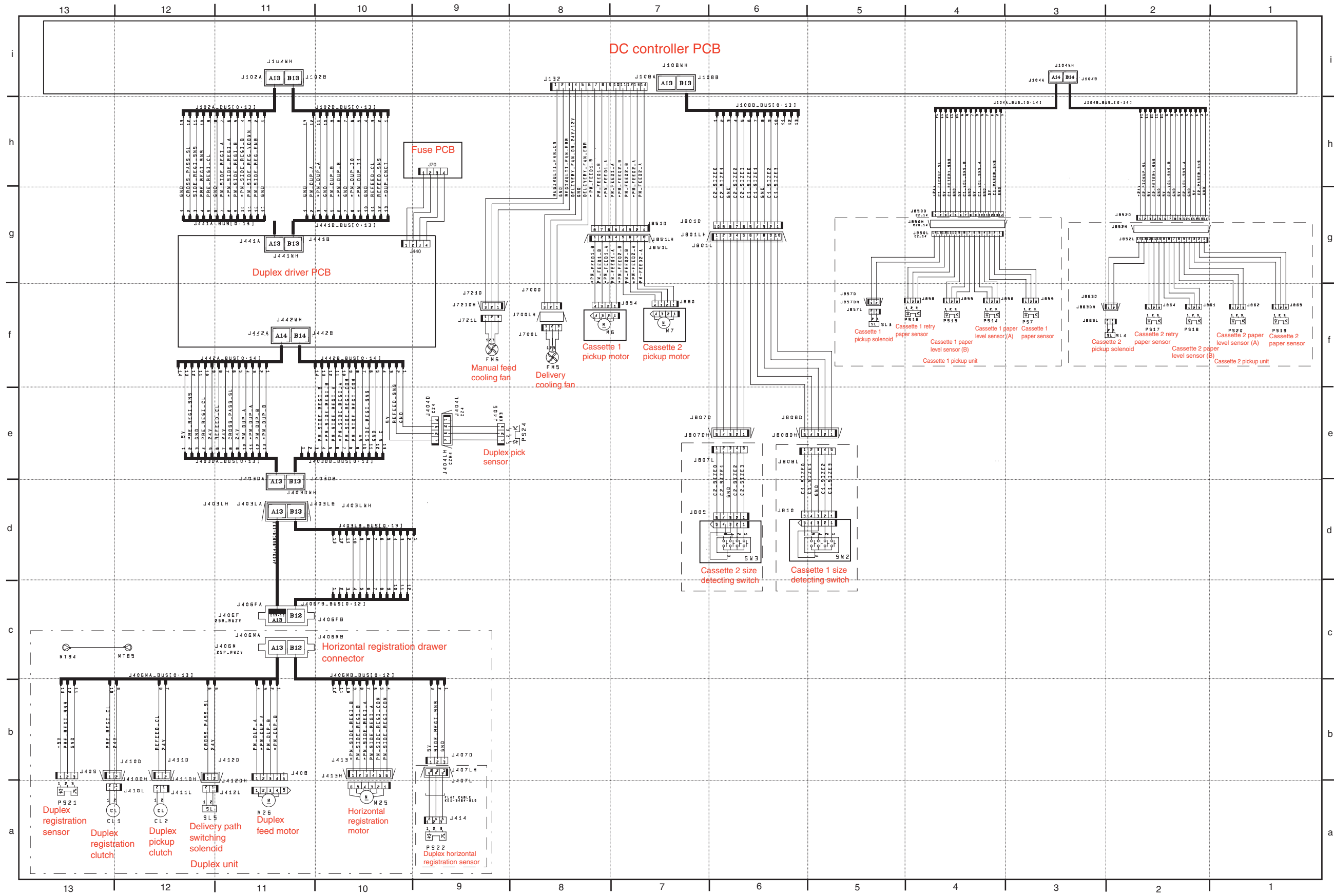

H. High-Voltage Circuit Diagram (8/10)

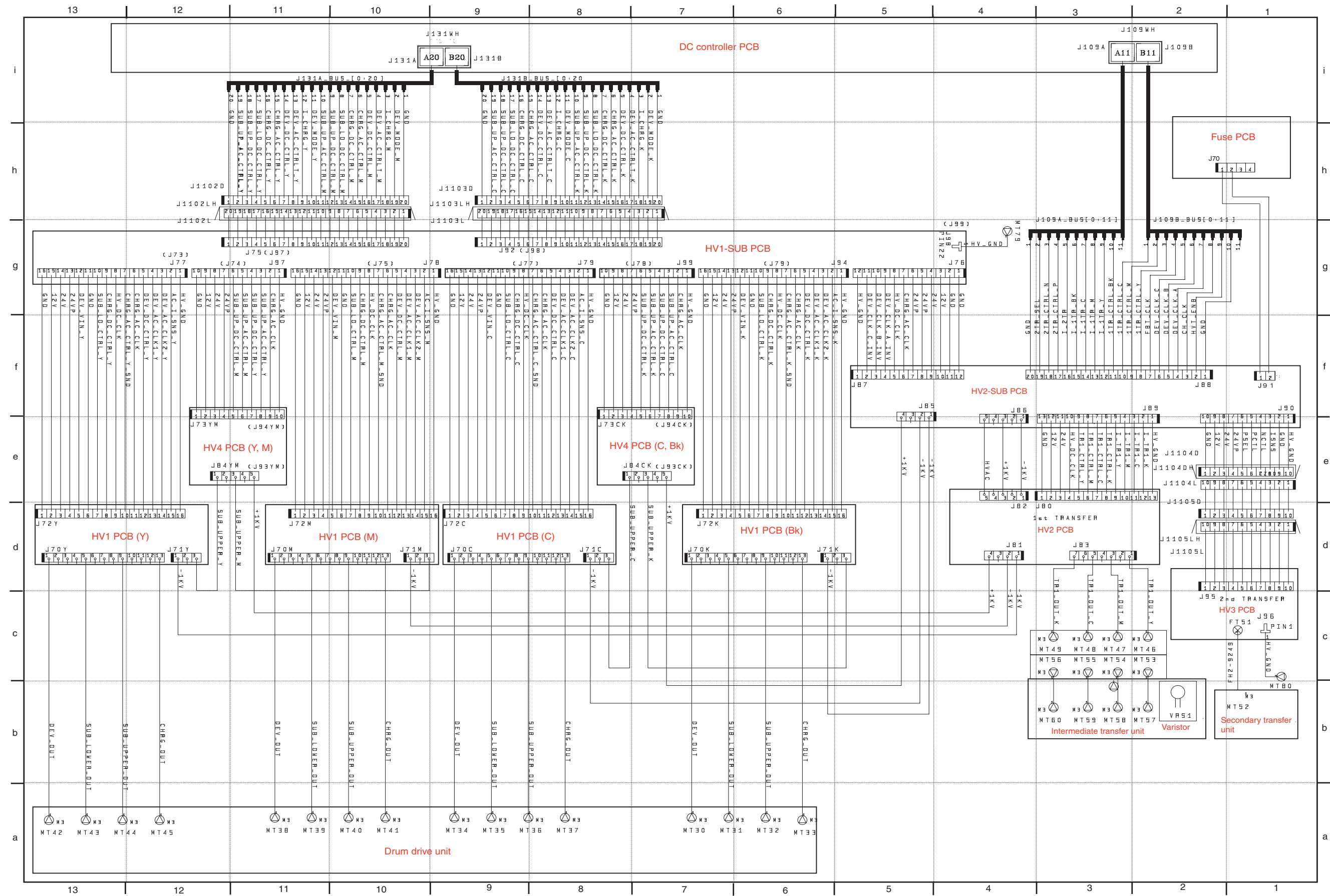

I. Fixing System Circuit Diagram (9/10)

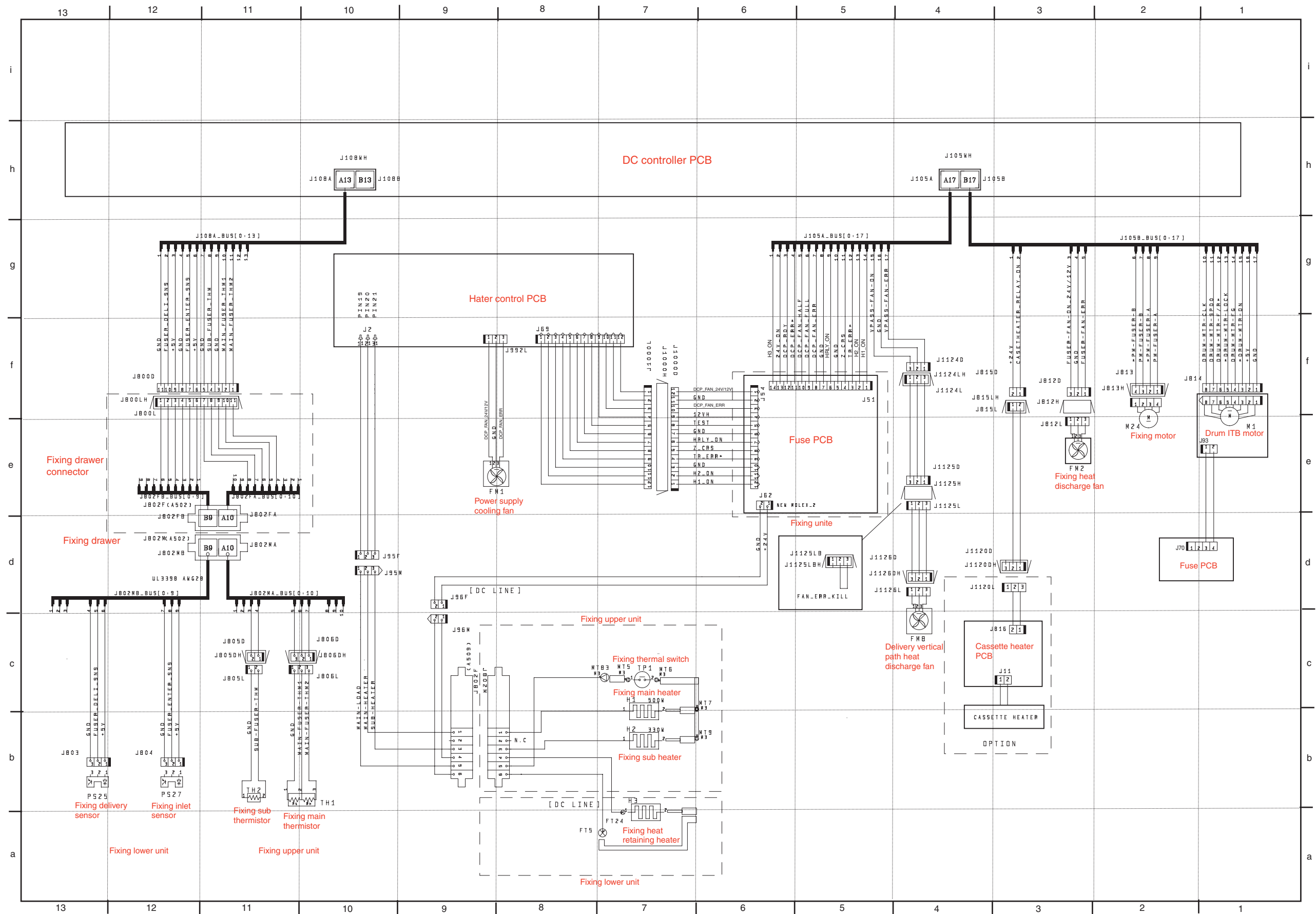

J. Feeder System Circuit Diagram (10/10)

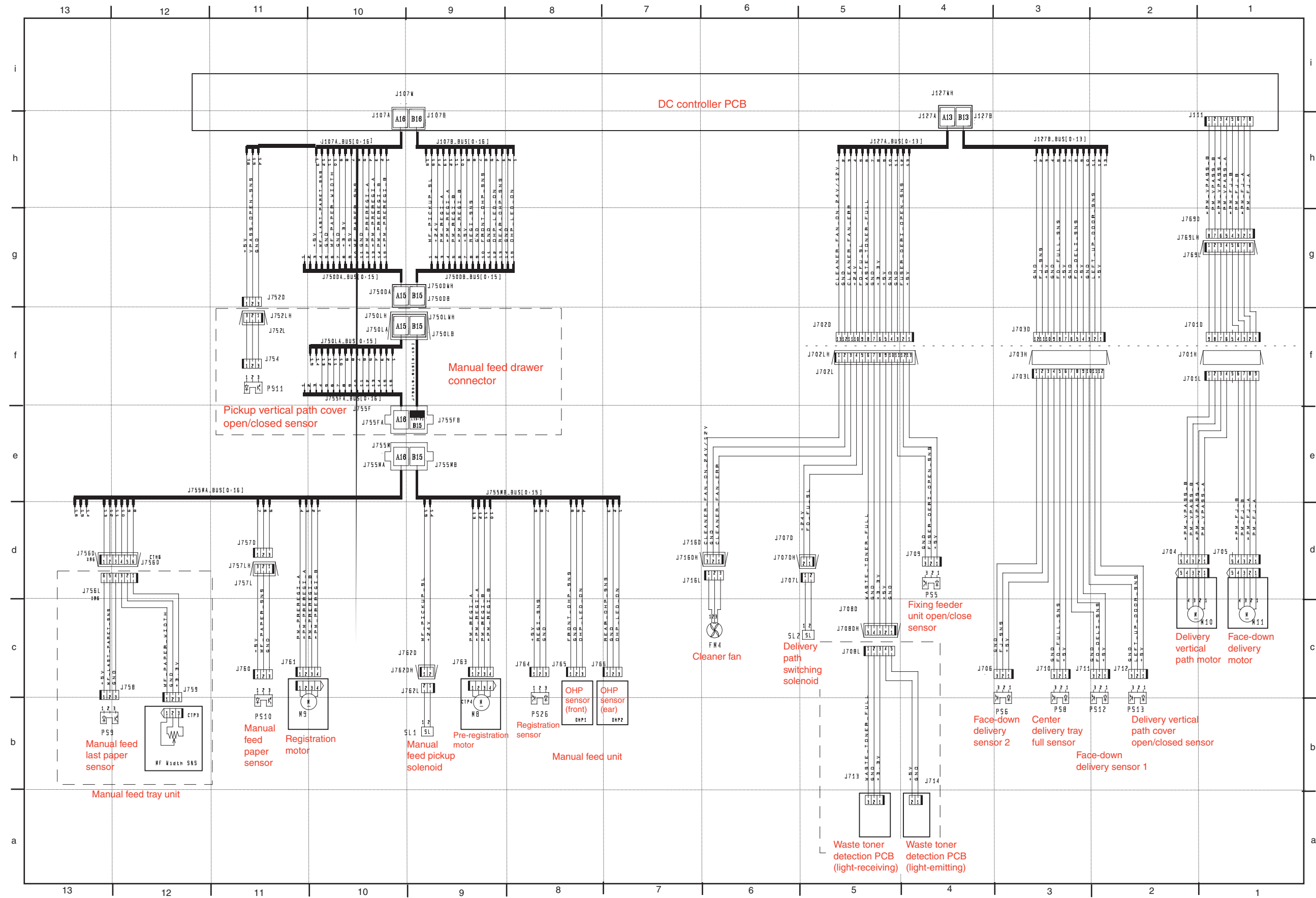

4 Special Tools

In addition to the standard tools set, the following special tools are required when servicing the machine:

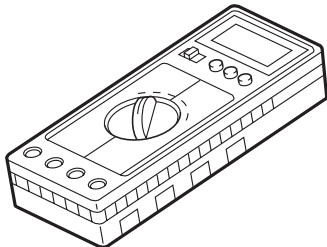
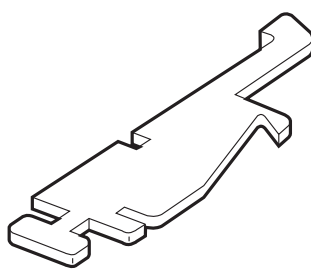
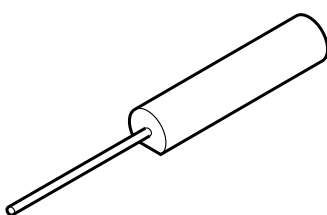
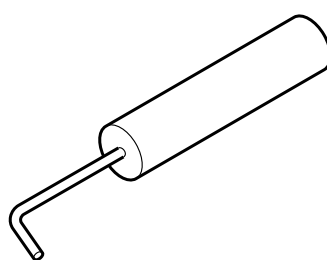
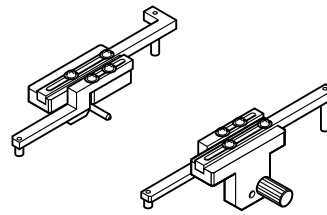
No.	Tool name	Tool No.	Ctgr	Appearance	Remarks
1	Digital multimeter	FY9-2002	A		Used for electrical checks; for adjustment of laser power in combination with the laser power checker.
2	Cover switch	TKN-0093	A		
3	Tester extension pin	FY9-3038	A		Used as a probe extension when making electrical checks.
4	Tester extension pin (L-shaped)	FY9-3039	A		Used as a probe extension when making electrical checks.
5	Mirror positioning tool (front, rear)	FY9-3040-000	B		Used for adjusting the distance between No. 1 and No. 2 mirrors (used in combination with the mirror positioning tool (rear)).

TA-400-01

APPENDIX

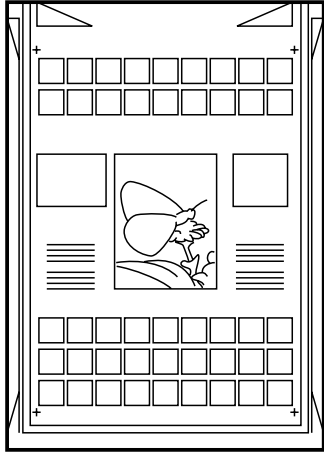
No.	Tool name	Tool No.	Ctgr	Appearance	Remarks
8	CA1 Test Sheet	FY9-9030	A		Used for adjusting/ checking images.

TA-400-02

5 Solvents and Oils

No.	Name	Uses	Composition	Remarks
1	Alcohol	Cleaning; e.g., glass, plastic, rubber; external covers.	Fluoride-family hydrocarbon Alcohol Surface activating agent Water	<ul style="list-style-type: none"> Do not bring near fire. Procure locally. Substitute: IPA (isopropyl alcohol)
2	Solvent #160	Cleaning; e.g., metal; oil or toner stain.	Fluoride-family hydrocarbon Chlorine-family hydrocarbon Alcohol	<ul style="list-style-type: none"> Do not bring near fire. Procure locally Substitute: MEK
3	Heat-resisting grease	Lubrication; e.g., fixing drive areas.	Mineral oil-family lithium soap Molybdenum disulfide	<ul style="list-style-type: none"> MO-138S Tool No.: CK-0427 (500 g/can)
4	Lubricating oil		Mineral oil (paraffin-family)	Tool No.: CK-0524 (100 cc)
5	Lubricating oil	Lubrication; i.e., drive areas, friction areas.	Silicone oil	Tool No.: CK-0551 (20 g)
6	Lubricating oil (EM-50L)	Lubrication; e.g., gears.	Special oil Special solid lubricating agent Lithium soap	Tool No.: HY9-0007
7	Lubricating oil	Lubrication; e.g., scanner rail	Silicone oil	Tool No.: FY9-6011 (50 cc)

TA-500-01

Prepared by
Office Imaging Products Device Quality Assurance Center
CANON INC.
Printed in Japan

REVISION 0 (JAN. 2003) (21767/23715/36850)

5-1, Hakusan 7-chome, Toride-shi, Ibaraki 302-8501 Japan



This publication is
printed on 100%
recycled paper.

Canon